



- (51) International Patent Classification:  
E21B 7/20 (2006.01) E21B 33/14 (2006.01)  
E21B 4/00 (2006.01)
- (21) International Application Number:  
PCT/US2013/027495
- (22) International Filing Date:  
22 February 2013 (22.02.2013)
- (25) Filing Language: English
- (26) Publication Language: English
- (30) Priority Data:  
61/601,676 22 February 2012 (22.02.2012) US
- (71) Applicant: WEATHERFORD/LAMB, INC. [US/US];  
2000 St. James Place, Houston, TX 77056 (US).
- (72) Inventor: TREVINO, Jose, A.; P.O. Box 55389, Houston,  
TX 77055 (US).
- (74) Agents: PATTERSON, William, B. et al.; Patterson &  
Sheridan, LLP, 3040 Post Oak Blvd., Suite 1500, Houston,  
TX 77056 (US).
- (81) Designated States (unless otherwise indicated, for every  
kind of national protection available): AE, AG, AL, AM,

AO, AT, AU, AZ, BA, BB, BG, BH, BN, BR, BW, BY, BZ, CA, CH, CL, CN, CO, CR, CU, CZ, DE, DK, DM, DO, DZ, EC, EE, EG, ES, FI, GB, GD, GE, GH, GM, GT, HN, HR, HU, ID, IL, IN, IS, JP, KE, KG, KM, KN, KP, KR, KZ, LA, LC, LK, LR, LS, LT, LU, LY, MA, MD, ME, MG, MK, MN, MW, MX, MY, MZ, NA, NG, NI, NO, NZ, OM, PA, PE, PG, PH, PL, PT, QA, RO, RS, RU, RW, SC, SD, SE, SG, SK, SL, SM, ST, SV, SY, TH, TJ, TM, TN, TR, TT, TZ, UA, UG, US, UZ, VC, VN, ZA, ZM, ZW.

(84) Designated States (unless otherwise indicated, for every kind of regional protection available): ARIPO (BW, GH, GM, KE, LR, LS, MW, MZ, NA, RW, SD, SL, SZ, TZ, UG, ZM, ZW), Eurasian (AM, AZ, BY, KG, KZ, RU, TJ, TM), European (AL, AT, BE, BG, CH, CY, CZ, DE, DK, EE, ES, FI, FR, GB, GR, HR, HU, IE, IS, IT, LT, LU, LV, MC, MK, MT, NL, NO, PL, PT, RO, RS, SE, SI, SK, SM, TR), OAPI (BF, BJ, CF, CG, CI, CM, GA, GN, GQ, GW, ML, MR, NE, SN, TD, TG).

**Published:**

— without international search report and to be republished upon receipt of that report (Rule 48.2(g))

(54) Title: LATCH ASSEMBLY

(57) Abstract: A releasable latch system used to releasably couple a surface casing to a conductor casing. In one embodiment, a latch assembly for coupling a first tubular to a second tubular includes a mandrel having a plurality of key slots; a housing for receiving the mandrel; a plurality of keys radially movable into engagement or out of engagement with a respective key slot; a collet configured to engage the housing and a respective key; and a retainer ring configured to hold the plurality of keys in engagement with the respective key slot.

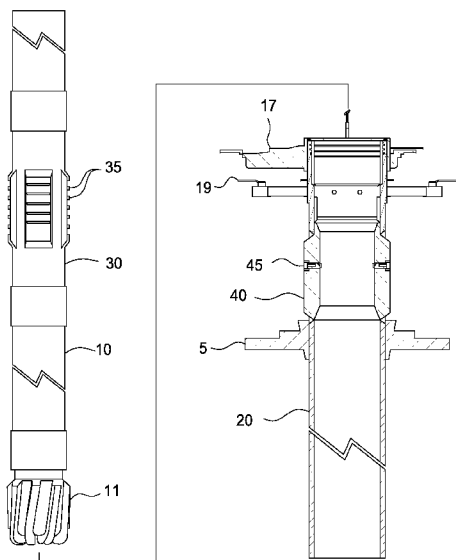

FIG. 1A

FIG. 1B

WO 2013/126827 A2

## LATCH ASSEMBLY

### BACKGROUND OF THE INVENTION

#### Field of the Invention

5 [0001] Embodiments of the present invention generally relate to methods and apparatus for drilling with casing. More particularly, the present invention relates to methods and apparatus for coupling two strings of casings.

#### Description of the Related Art

10 [0002] In the oil and gas producing industry, the process of cementing casing into the wellbore of an oil or gas well generally comprises several steps. For example, a conductor pipe is positioned in the hole or wellbore and may be supported by the formation and/or cemented. Next, a section of a hole or wellbore is drilled with a drill bit which is slightly larger than the outside diameter of the casing which will be run into the well.

15 [0003] Thereafter, a string of casing is run into the wellbore to the required depth where the casing lands in and is supported by a well head in the conductor. Next, cement slurry is pumped into the casing to fill the annulus between the casing and the wellbore. The cement serves to secure the casing in position and prevent migration of fluids between formations through which the casing has passed. Once the cement  
20 hardens, a smaller drill bit is used to drill through the cement in the shoe joint and further into the formation.

[0004] Typically, when the casing string is suspended in a subsea wellhead or casing hanger, the length of the casing string is shorter than the drilled open hole section, allowing the casing hanger or high pressure wellhead housing to land into the  
25 wellhead prior to reaching the bottom of the open hole. Should the casing reach the bottom of the hole prior to landing the casing hanger or high pressure wellhead housing, the system would fail to seal and the casing would have to be retrieved or remedial action taken.

[0005] The difficulty in positioning the casing at the proper depth is magnified in  
30 operations where casing is used as the drill string. In general, drilling with casing allows the drilling and positioning of a casing string in a wellbore in a single trip. However, drilling with casing techniques may be unsuitable in the instance where the

casing string must land in a wellhead. To reach proper depth to land a casing hanger or high pressure wellhead housing in the wellhead, the casing string must continue to drill to the proper depth. However, continued rotation while the casing hanger or high pressure wellhead housing is near, or in, the wellhead may damage the wellhead and/or its sealing surfaces. Thus, the casing string may be prematurely stopped to avoid damaging the wellhead.

[0006] There is a need, therefore, for improved methods and apparatus for coupling two strings of casing. There is also a need for apparatus and methods for drilling with a casing and landing the casing in a wellhead.

## 10 SUMMARY OF THE INVENTION

[0007] In one embodiment, a latch assembly for coupling a first tubular to a second tubular includes a mandrel having a plurality of key slots; a housing for receiving the mandrel; a plurality of keys radially movable into engagement or out of engagement with a respective key slot; a collet configured to engage the housing and a respective key; and a retainer ring configured to hold the plurality of keys in engagement with the respective key slot.

[0008] In another embodiment, a latch assembly for coupling a first tubular to a second tubular includes a mandrel having a plurality of key slots; a housing for receiving the mandrel; a plurality of keys radially movable into engagement or out of engagement with a respective key slot; a retainer ring selectively rotatable relative to the housing; a setting member for rotating the retainer; and a plurality of openings circumferentially spaced on the housing for receiving the setting member.

[0009] In another embodiment, a latch assembly for coupling a first tubular to a second tubular includes a mandrel; a housing for receiving the mandrel, the housing including a plurality of segments having keys; and a load block releasably coupled to the mandrel, the load block having slots for mating with the keys.

[0010] In another embodiment, a latch assembly for coupling a first tubular to a second tubular includes a mandrel having a plurality of key slots; a housing for receiving the mandrel; a plurality of keys radially movable into engagement or out of engagement with a respective key slot; and a rotatable sleeve for radially moving a respective key and coupled to the key using a shearable thread connection.

[0011] In another embodiment, a latch assembly for coupling a first tubular to a second tubular includes a mandrel coupled to a first tubular and having a longitudinal groove and an arcuate groove; and a housing coupled to the second tubular and adapted to receive the mandrel, wherein the housing includes a first pin for coupling  
5 with the longitudinal groove and a second pin for coupling with the arcuate groove.

### **BRIEF DESCRIPTION OF THE DRAWINGS**

[0012] So that the manner in which the above recited features of the present invention can be understood in detail, a more particular description of the invention, briefly summarized above, may be had by reference to embodiments, some of which  
10 are illustrated in the appended drawings. It is to be noted, however, that the appended drawings illustrate only typical embodiments of this invention and are therefore not to be considered limiting of its scope, for the invention may admit to other equally effective embodiments.

[0013] Figures 1A-B illustrate an embodiment of a latch system for coupling two  
15 casings.

[0014] Figures 2-6 illustrate an embodiment of a latch mechanism.

[0015] Figures 7-8 show the installation of the first casing in the second casing.

[0016] Figures 9-12 illustrate the operation sequence to engage the load keys to the key slots of the latch mechanism of Figure 4.

20 [0017] Figure 13 shows the first casing and the second casing ready to be deployed.

[0018] Figures 14-18A illustrate the operation sequence to release the first casing from the second casing.

25 [0019] Figure 19 illustrates two additional embodiments for releasing the retainer pin.

[0020] Figures 20-22 illustrate another embodiment of a latch mechanism.

[0021] Figures 23-33 illustrate another embodiment of a latch mechanism.

[0022] Figures 34-38 illustrate another embodiment of a latch mechanism.

[0023] Figures 39-49 illustrate another embodiment of a latch mechanism.

[0024] Figures 50-54 illustrate another embodiment of a latch mechanism.

[0025] Figures 55A-57 illustrate another embodiment of a latch mechanism.

## 5 **DETAILED DESCRIPTION OF THE PREFERRED EMBODIMENT**

[0026] Embodiments of the present invention provides a releasable latch mechanism for coupling a first tubular to a second tubular. For example, the latch mechanism may be used to couple a first casing to a second casing positioned inside the first casing. The latch mechanism may be released to allow the second casing to  
10 move relative to the first casing.

[0027] In one embodiment, a releasable connection is used to couple a conductor casing to a surface casing during jetting operations. Thereafter, the releasable connection is activated to release the surface casing after the jetting process is complete. The releasable connection is adapted to minimize the potential for  
15 inadvertently release or re-lock. Also, the releasable connection may optionally be configured to release upon the occurrence of two or more events, for example, axial then rotation. In another embodiment, the releasable connection is configured for axial adjustment to allow proper bit “stick-out or stick-in” relative to the conductor casing for jetting operations. In yet another embodiment, the releasable connection is  
20 configured for installation even under sea conditions including and not limited to heave, sea current, and tide. In yet another embodiment, the releasable connection is configured to carry axial loads from at least the weight of the conductor, weight of the low pressure wellhead, and jetting friction. In yet another embodiment, the releasable connection may include a latch mechanism that allows the bottom hole  
25 assembly and surface casing to pass through, in the event there is a need to retrieve the BHA after the conductor has been jetted. In yet another embodiment, the latch is compatible with inclination measuring equipment. In yet another embodiment, the releasable connection allows for simple rig up.

[0028] Figures 1A-B illustrate an embodiment of a latch system for coupling a first casing 10 (such as a 22” casing) to a second casing 20 (such as a 36” casing).  
30

Figure 1A shows the first casing 10 provided with a drilling member 11 at a lower end and a latch mandrel 30 connected between the casing sections. The latch mandrel 30 includes key slots 35 disposed on the exterior of the latch mandrel 30. The key slots 35 may be provided as a continuous circumferential slot or discreet slot segments. As shown in Figure 1A, the key slots 35 are provided as four circumferentially spaced segments. In addition to being circumferentially positioned, a plurality of key slots 35 may be axially spaced along the latch mandrel 30. The axial spacing of the key slots 35 allows relative axial positioning of the first casing 10 relative to the second casing 20.

10 [0029] Figure 1B shows the second casing 20 being held by the slips of a surface table 5 which may be located on the rig floor or the rotary table. The second casing 20 includes a low pressure wellhead 21, latch housing 40, and a string of casing. The latch housing 40 includes one or more load keys 45 for engaging the key slots 35 of the latch mandrel 30. In this embodiment, two load keys 45 are positioned 180 degrees apart, although any suitable number of load keys may be used. The load keys 45 are radially movable to engage or disengage from the key slots 35.

[0030] **Latch Concept 1**

[0031] Figures 2-6 illustrate an embodiment of a latch mechanism 100 for engaging and disengaging the load keys 45 from the key slots 35. Referring to Figures 3 and 4, the latch mechanism 100 includes a retainer 60 for retaining the load key 45. The retainer 60 is ring shaped and is formed by joining at least two arcuate segments. The arcuate segments may be joined by inserting a retainer pin 65 through the hinges of two adjacent segments. In one embodiment, the retainer pin 65 may be threadedly coupled to a slot 47 in the housing 40. A telescopic member 52 is coupled to the upper end of the retainer pin 65 using a universal joint 53. The other end of the telescopic member 52 includes a handle 54 that can be rotated by a remotely operated vehicle ("ROV") to release the retainer pin 65 from the hinges of the retainer segments. A ball joint 55 may be used to couple the telescopic member 52 to the vertical positioning equipment 17 (optionally equipped with a "bullseye" 19) to facilitate rotation of the telescopic member 52. In another embodiment, the upper end of the telescopic member 52 is coupled to a torque tool receiver 56 using another universal joint 57. A ROV may operate a torque tool to engage the torque tool receiver 56 in order to rotate the retainer pin 65.

[0032] The load keys 45 are coupled to the housing 40 using the retainer 60, a collet 70, a jam nut 80, and a holding bolt 90. As shown in Figure 4, the load key 45 includes a connector shaft 48 that is inserted through an opening 43 in the housing 40 from the interior side of the housing 40. The connector shaft 48 is coupled to the retainer 60, the collet 70, the jam nut 80, and the holding bolt 90 at the exterior side of the housing 40. Figure 5 is a cross-sectional view showing the load keys 45 in the retracted position. Figure 6 is a partial enlarged view of the load key 45 retracted in the housing 40. The collet 70 is an annular ring having an outer set of collet fingers and an inner set of collet fingers that are shorter than the outer collet fingers. The outer set of collet fingers is configured to engage a groove 41 in the housing 40. The inner set of collet fingers is configured to engage a groove 71 around the connector shaft 48. During run-in the collet 70 is not locked into place and is movable (also referred to as "float") relative to the retainer 60. The jam nut 80 abuts the end of the load key connector shaft 48 and is threadedly coupled to the load key retainer 60. The holding bolt 90 includes a shoulder that abuts the jam nut 80 and a head that sets in the counter bore of the jam nut 80 and threadedly engages the connector shaft 48. The connector shaft 48 may include bore 91 for receiving grease and a fitting 92 for closing the bore 91.

[0033] Figure 7 shows the installation of the first casing 10 in the second casing 20. As shown, the bottom hole assembly of the first casing 10 is being lowered into the latch housing 40 of the second casing 20. The load keys 45 are in the retracted position at this time. In Figure 8, the first casing 10 has been lowered sufficiently so that the mandrel 30 is positioned adjacent the housing 40. The plurality of slots 35 on the mandrel 30 allows the placement of the first casing 10 relative to the second casing 20 to be adjusted so a sufficient amount of the bottom hole assembly extends below the second casing 20.

[0034] Figures 9-11A illustrate the operation sequence to engage the load keys 45 to the key slots 35. Initially, the appropriate key slot 35 is aligned with the load key 45, as shown in Figure 9. Then, the holding bolt 90 is removed, as shown in Figure 10. The jam nut 80 is then rotated to push the load key 45 into engagement with key slot 35, as shown in Figure 11. Because of the abutment, the collet 70 is also pushed in during rotation of the jam nut 80. The collet 70 is moved sufficiently so that the outer collet fingers expand and engage the groove 41 in the housing 40, as shown in

the enlarged view of Figure 11A. Figure 12 shows the load keys 45 of the housing 40 engaged with the key slots 35 of the mandrel 30.

[0035] Figure 13 shows the first casing 10 and the second casing 20 ready to be deployed. The first casing 10 is lifted up from the surface table 5, and then the slips are removed. Thereafter, the first and second casings 10, 20 are lowered to the sea floor and urged through the formation. The second casing 20 may be drilled down or jetted to the desired depth, such as positioning the housing 40 at or above the mud line.

[0036] After reaching the desired depth, the first casing 10 is released from the second casing 20. As shown in Figure 14, a ROV may be used to unscrew the retainer pin 65 by gripping the handle 54 on the telescopic member 52. In another embodiment, the ROV may use a torque tool to engage the torque tool receiver 56 and to rotate the telescopic member 52. Rotation of the retainer pin 65 relative to the housing 40 pulls the retainer pin 65 from the hinges on the segments of the retainer 60. Figure 14A shows the retainer pin 65 disengaged from the retainer 60. After the pin 65 is released, a downward force is applied to the first casing 10, which in turn, pushes the load keys 45 radially outward, as shown in Figure 15. Outward movement of the load keys 45 also pushes out the jam nut 80 and the retainer 60. Figure 16 is a cross-sectional view showing the separation of the hinges of two retainer segments 60. Figure 17 is an enlarged view of the load key 45 after retraction. The load key 45 has retracted sufficiently to allow the inner collet fingers to engage the groove 71 on the load key 45. Engagement of the outer and inner collet fingers to their respective grooves 41, 71 holds the load key 45 in the retracted position. After release from the second casing 20, the first casing 10 may continue to drill down, as shown in Figure 18, 18A.

[0037] Figure 19 illustrates two additional embodiments for releasing the retainer pin 65. Both embodiments are operated using hydraulics. Referring to the embodiment on the left side of Figure 19, the retainer pin 65 is coupled to and moveable with a hydraulic piston 170. In one embodiment, an adapter block 171 is used to couple the retainer pin 65 to the piston 170. Hydraulic fluid to operate the piston 170 may be supplied by hydraulic lines 172 from a hydraulic manifold 175. The manifold 175 is configured to receive a stab member 176 controlled by a ROV. In operation, the ROV inserts the stab member 176 into the manifold 175. To release



the pin 65, hydraulic fluid is supplied through the hydraulic line 172 configured to lift the piston 65. The retainer pin 65 is lifted out of the retainer 60 as the piston 170 is lifted by the hydraulic fluid.

[0038] Referring now to the embodiment on the right side of Figure 19, a cable 180 is connected between the retainer pin 65 and a hydraulic piston 181. Hydraulic fluid to pull the piston 181 may be supplied by hydraulic lines 182 from a hydraulic manifold 175. The manifold 175 is configured to receive a stab member 176 controlled by a ROV. The retainer pin 65 is also releasably coupled to a steel cable 180. In one embodiment, a shearable member such as a shear pin 188 is used to couple the retainer pin 65 to the latch housing 40. The guide support 186 is attached to the housing 40 and includes a roller guide 187 for the cable 180. In operation, the ROV inserts the stab member 176 into the manifold 175. To release the pin 65, hydraulic fluid is supplied through the hydraulic line 182 configured to lift the piston 181. The piston 181 supplies a sufficient upward force to shear the shear pin 188, thereby allowing the retainer pin 65 to be lifted out of the retainer 60.

#### [0039] Latch Concept 2

[0040] Figures 20-22 illustrate another embodiment of a latch mechanism 200 for engaging and disengaging the load keys 45 from the key slots 35. Figure 20 shows the mandrel 30 coupled to the housing 40 via the load keys 45 and the key slots 35. The coupling may be performed at the surface using standard tools. At the mud line, an ROV can use a torque tool to disengage the load key 45. An exemplary torque tool is a torque tool class 1-4 commercially available from Oceaneering.

[0041] Figure 21 is a cross-sectional view of the mandrel 30 coupled to the housing 40 via the load key 45. Figure 22 is a partial cross-sectional side view of the mandrel 30 coupled to the housing 40 via the load key 45. As seen in these Figures, the connector shaft 48 of the load key 45 is coupled to an adjustment nut 138, wherein rotation of the adjustment nut 138 causes radial movement of the load key 45. The adjustment nut 138 is disposed in the bore of a torque tool receiver 148 connected to the housing 40. The torque tool receiver 148 may include an engagement slot 149 for engaging a torque tool. At the surface, the torque tool or other tools may be used to rotate the adjustment nut 138 to cause the load key 45 to move radially inward into engagement with the slot 35 of the mandrel 30. After the

second casing 20 reaches the desired depth, the ROV may operate a torque tool to engage the torque tool receiver 148 and the adjustment nut 138, which then can be rotated to retract the load key 45, thereby freeing the first casing 10 to continue drilling.

5 **[0042] Latch Concept 3**

[0043] Figure 23 illustrate another embodiment of a latch mechanism 300 for engaging and disengaging the load keys 345 from the key slots 35. In this embodiment, a retainer ring 360 is disposed around the housing 340 and may include two or more arcuate segments hinged together. The retainer ring 360 may be  
10 rotatable relative to the housing 340 and may optionally be disposed in a groove 344 in the housing 340. Figure 24 is a cross-sectional view showing the retainer ring 360 in a groove 344 and the load key 345 engaged with the key slot 35 of the mandrel 30.

[0044] Figure 25 is a cross-sectional view of the retainer ring 360 and the load key 345 in the housing 340. Figures 26 and 26A are enlarged partial views of Figure 25.  
15 The load key 345 is shown in the retracted position and ready to receive the slots 35 of the mandrel 30. A lock bolt 390 is used to keep the load key 345 in the retracted position. Using the load key 345 as a reference point, *i.e.*, 0° position, the outer surface of the housing 340 may include at least three receiving openings 361, 362, 363 for receiving a position setting pin 350. In one embodiment, the receiving  
20 openings 361-363 are spaced 15° degrees apart. The setting pin 350 is mated with the third receiving openings 363 when the lock bolt 390 is engaged with the load key 345. A load key catch 355 may be positioned in the retainer ring 360 adjacent the second receiving opening 362. The load key catch 355 is configured to receive and hold the connector shaft 348 of the load key 345. In one embodiment, the load key  
25 catch 355 is a ring adapted to frictionally hold the load key 345. The number of load key catches 355 may correspond to the number of load keys 345. The connector shaft 348 of the load key 345 includes a bore 346 that is connected to a network of channels 347 in the load key 345. Grease or other fluid may be supplied through the bore 346 to the channels 347 in order provide grease between the load key 345 and  
30 the housing 340. A grease fitting may be used to facilitate injection of grease into the bore 346.

[0045] Figure 27 is a cross-sectional view showing the mandrel 30 (and first casing 10) inserted into the housing 340 (and second casing 20), which may take place in the moon pool of a vessel such as a rig or ship. After the key slots 35 are aligned with the load key 345, lock bolt 390 is removed and the load keys 345 are moved radially into engagement with the key slot 35, as shown in Figures 27 and 27A. Thereafter, grease may be injected through the fitting and into the bore 346 and the network of channels 347, as shown in Figure 28. The grease may fill the space between the load key 345 and the housing 340. Optionally, as shown in Figure 28A, additional grease may be provided in the pocket 391 in the retainer ring 360 used to accommodate the lock bolt 390. A plug 392 may be used to close off the pocket 391. Referring to Figure 29, after supplying the grease, setting pin 350 is disengaged from the third receiving opening 363. The retainer ring 360 is then rotated so that the setting pin 350 is allowed to engage the second receiving opening 362. As shown in Figure 29, the retainer ring 360 has rotated 15 degrees and the setting pin 350 has engaged the second receiving opening 362. As a result of the rotation, the pocket 391 is moved away from the load key 345 and the load key 345 is prevented from retraction. The first casing and the second casing may now be released from the slips and drilled or jetted into the formation.

[0046] After reaching the target depth for the second casing, the mandrel 30 is released from the housing 340. To do so, a ROV is used to manipulate the setting pin 350 and the retainer ring 360. The setting pin 350 is disengaged from the second receiving opening 362, and the retainer ring 360 is then rotated so that the setting pin 350 is allowed to engage the first receiving opening 361. As shown in Figure 30, the retainer ring 360 has rotated 15 degrees and the setting pin 350 has engaged the first receiving opening 361. As a result of the rotation, the load key catch 355 has moved adjacent to the connector shaft 348 of the load key 345.

[0047] In one embodiment, to ensure the position of the retainer ring 360 is proper, a visual indicator such as arrows 396, 397 may be provided on the exterior surface of the housing 340 and the retainer ring 360, as shown in Figure 31. In another embodiment, an optional stop pin 366 may be used, as shown in Figure 32. The stop pin 366 may be provided in a slot 367 formed in the retainer ring 360. The end of the slot 367 is arranged to correspond to the proper position of the retainer ring 360 relative to the load key 345.

[0048] After the load key catch 355 is in position, a downward force is applied to the first casing 10, which in turn, pushes the load keys 345 radially outward, as shown in Figure 33. The connector shaft 348 of the load keys 345 is urged into engagement with the load key catch 355, as shown in Figure 33. It can be seen the load key 345 has been retracted into the housing 340 and the mandrel 30 is free to move downward.

[0049] **Latch Concept 4**

[0050] Figure 34 illustrate another embodiment of a latch mechanism 400 for engaging and disengaging the load keys 445 from the key slots 35. In this embodiment, the load key 445 is actuated using hydraulics. As shown in Figure 35, the connector shaft 448 of the load key 445 is connected to and movable with a piston 446. The piston 446 is retained a chamber 443 of the housing 440 using a stop nut 447. As shown, the piston 446 is located at the distal end of the chamber 443, which positions the load key 446 in the extended position and engaged to the key slot 35 of the mandrel 30.

[0051] As shown in Figure 34, the housing 440 includes a hydraulics panel 450 for connection with one or more hydraulic lines. A ROV may be used to connect the hydraulic lines to the panel 450. From the panel 450, hydraulic fluid may be directed a particular port(s) to either engage or disengage the load key 445. Figure 36 shows the activation port 441 for supplying fluid to the portion of the chamber 443 between the piston 446 and the plug 447. Fluid supplied to this portion of the chamber 443 will cause the load key 445 to move radially into engagement with the mandrel 30. As shown, the piston 446 is at the distal end of the chamber 443. Figure 37 shows the deactivation port 442 for supplying fluid to the portion of the chamber 443 on the other side of the piston 446. Fluid supplied to this portion chamber 443 will cause the load key 445 to move radially to retract from the mandrel 30. As shown, the piston 446 is at the proximal end of the chamber 443. Figure 38 shows the load key 445 disengaged from key slot the mandrel 30.

[0052] **Latch Concept 5**

[0053] Figures 39-42 illustrate the components of another embodiment of a latch mechanism 500 for engaging and disengaging the load keys 545 from the key slots

535. The housing 540 includes a plurality of segments having keys 545 on an interior surface. Referring to Figures 43 and 44, the mandrel 530 is provided with a plurality of axial load blocks 532 having slots 535 on an exterior surface. The slots 535 are adapted to engage the keys 545 on the housing 540. The axial load blocks 532 are  
5 releasably coupled to the mandrel 530 using a lever 537 coupled to a T-shaped groove 538. The lever 530 may include a handle 539 for the ROV to manipulate. In one embodiment, the mandrel 530 includes four axial load blocks 532 circumferentially spaced on the mandrel 530. Also, the housing 540 includes four segments 542 circumferentially spaced in the housing 540.

10 [0054] To couple the first casing 10 to the second casing 20, the mandrel 530 is inserted into the housing 540 and the load blocks 532 are positioned between adjacent segments 542. In this respect, the mandrel 530 is free to move axially relative to the housing 540. After the first casing is positioned at the desired location, the mandrel 530 is rotated so that the slots 535 engage the keys 545 on the  
15 segments 542. Thereafter, one or more torque keys 548 are inserted in between adjacent segments 542 to prevent the slots 535 from rotating out of engagement with the keys 545. The torque keys 548 may include an extended handle 549 that protrudes out of the top of the second casing, as shown in Figures 44 and 45.

[0055] To release the first casing 10, the ROV is operated to pull the torque keys  
20 548 out of the second casing 20. Then the first casing 10 is rotated so that the axial load block 532 is between two adjacent segments 542 of the housing 540, thereby disengaging the slots 535 from the keys 545. As shown, the first casing 10 is rotated one-eighth turn to disengage the slots 535. In this respect, the mandrel 530 is again free to move axially relative to the housing 540. Then, the first casing 10 is lifted until  
25 the axial load blocks 532 are above the low pressure wellhead 21, as shown in Figures 46 and 46A. Figure 47 shows a flange 534 of the lever 537 disposed in the T-shaped slot 538 of the mandrel 530. The ROV is operated to grab the handle 539 and pull the flange 534 out of the T-shaped slot 538. Figure 47A shows the lever 537 lifted up relative to the slots 535. Then, the lever 537 is pivoted relative to the load  
30 block 532, as shown in Figures 47B and 48. In Figure 49, the axial load block 532 is removed from the mandrel 530. The mandrel 530 and the first casing 10 are now free to continue drilling.

**[0056] Latch Concept 6**

[0057] Figures 50-54 illustrate another embodiment of a latch mechanism 600 for engaging and disengaging the load keys 645 from the key slots 35. Figures 50-51 show the mandrel 30 coupled to the housing 640 via the load keys 645 and the key slots 35. The coupling may be performed at the surface using standard tools. Figure 51 also shows one of the keys 645 being disengaged from the slot 30.

[0058] Referring to Figures 51-54, the connector shaft 648 of the key 645 is threadedly coupled to a bore 651 of an adjusting nut 650. Rotation of the nut 650 moves the key 645 radially inward or outward. The threads 656 connecting the shaft 648 to the adjusting nut 650 are shearable when a sufficient amount of force is applied. A key holder 658 is disposed inside the bore 651 of the adjusting nut 650 and is configured to hold the connector shaft 648 of the load key 645 in place. A nut cover 659 is used to couple the adjustment nut 650 to the housing 640 while allowing the nut 650 to rotate relative to the housing 640.

[0059] Figure 52 shows the load key 645 engaged with the slot 35 of the mandrel 30. A torque tool, or other tool suitable for rotating the adjusting nut 650, may be used to rotate the adjusting nut 650 in order to advance the load key 645 toward engagement with the mandrel 30. After coupling the second casing to the first casing, both casings are drilled or jetted until the second casing reaches target depth. Referring to Figure 53, a downward force 643 is then applied to the second casing, which force is transferred to the load key 645, thereby causing retraction of the load key 645 from the slot 35. The force applied is sufficient to shear the threads 656 to allow the retraction of the load key 645, as shown in Figure 53. Figure 54 shows the load key 645 fully retracted and the threads sheared. The load key 645 is held in this position by the key holder 658. The first casing 10 is now free to continue drilling down.

**[0060] Latch Concept 7**

[0061] Figures 55-57 illustrate another embodiment of a latch mechanism 700 for coupling the mandrel 730 of the first casing to the housing 740 of the second casing. As shown in Figures 55A-C, the housing 740 includes four sets of dual aperture arrangement circumferentially spaced around the housing 740. Each of the apertures

725 is adapted to threadedly receive a pin 744, 745. The outer surface of the mandrel 730 may include four sets of grooves. Each set of grooves include a longitudinal groove 734 and an arcuate groove 735. In one embodiment, the arcuate groove may be a j-slot groove. The lower end of the j-slot groove 735 is configured to slidably engage a pin 745 protruding from the aperture 725. A recess 747 may be provided between adjacent sets of grooves and adjacent sets of aperture arrangements, as shown in Figure 56. The recess 747 may allow fluid flow past the mandrel 730.

[0062] To couple the mandrel 730 to the housing 740, a pin 745 is inserted into the lower aperture 725 and rotated to protrude out of the housing 740. The lower end of the j-slot groove 735 is aligned with the pin 745 so that lowering the mandrel 730 into the housing 740 allows the pin 745 to slide along the j-slot groove 735. The mandrel 730 is then rotated to track the pin 745 along the j-slot groove 735, and thereafter the mandrel 730 is pulled up to place the pin 745 at the end of the j-slot groove 735. Then, a second pin 744 is rotated to protrude out of the second aperture 725 and engage the longitudinal groove 734. The second pin 744 prevents inadvertently release of the mandrel 730 from the housing 740. Figure 57 shows the two pins 744, 745 engaged with their respective grooves 734, 735.

[0063] To release the mandrel 730, all pins 744 and 745 are rotated out of engagement with the longitudinal groove 734. An ROV may be used to rotate the pins 744 and 745.

[0064] While the foregoing is directed to embodiments of the present invention, other and further embodiments of the invention may be devised without departing from the basic scope thereof, and the scope thereof is determined by the claims that follow.

**Claims:**

1. A latch assembly for coupling a first tubular to a second tubular, comprising:  
a mandrel having a plurality of key slots;  
5 a housing for receiving the mandrel;  
a plurality of keys radially movable into engagement or out of engagement with  
a respective key slot;  
a collet configured to engage the housing and a respective key; and  
a retainer ring configured to hold the plurality of keys in engagement with the  
10 respective key slot.
2. The latch assembly of claim 1, further comprising a retaining pin for coupling at  
least two segments of the retainer ring.
- 15 3. The latch assembly of claim 2, further comprising a nut threadedly coupled to  
the retainer ring.
4. The latch assembly of claim 3, further comprising a holding bolt coupled to a  
respective key.  
20
5. The latch assembly of claim 1, wherein the plurality of keys include a fluid  
channel.
6. The latch assembly of claim 1, further comprising a nut threadedly coupled to  
25 the retainer ring.
7. The latch assembly of claim 1, wherein the keys include a connector shaft  
coupled to the retainer ring.
- 30 8. The latch assembly of claim 1, wherein the collet is a dual collet.
9. A latch assembly for coupling a first tubular to a second tubular, comprising:  
a mandrel having a plurality of key slots;



a housing for receiving the mandrel;

a plurality of keys radially movable into engagement or out of engagement with a respective key slot;

a retainer ring selectively rotatable relative to the housing;

5 a setting member for rotating the retainer;

a plurality of openings circumferentially spaced on the housing for receiving the setting member.

10 10. The latch assembly of claim 9, wherein three openings are provided on the housing.

11. The latch assembly of claim 10, wherein the three openings are equally spaced apart.

15 12. The latch assembly of claim 9, further comprising a key catch disposed in the retainer ring for holding a respective key.

13. A latch assembly for coupling a first tubular to a second tubular, comprising:  
a mandrel;

20 a housing for receiving the mandrel, the housing including a plurality of segments having keys; and

a load block releasably coupled to the mandrel, the load block having slots for mating with the keys.

25 14. The latch assembly of claim 13, wherein the load block further comprises a lever for releasing the load block from the mandrel.

15. The latch assembly of claim 13, further comprising a torque key disposable  
between two adjacent segments to retain the housing and the mandrel in a coupling  
30 relationship.

16. A latch assembly for coupling a first tubular to a second tubular, comprising:  
a mandrel having a plurality of key slots;  
a housing for receiving the mandrel;

a plurality of keys radially movable into engagement or out of engagement with a respective key slot; and

a rotatable sleeve for radially moving a respective key and coupled to the key using a shearable thread connection.

5

17. The latch assembly of claim 16, further comprising a key retainer disposed in the rotatable sleeve.

18. A latch assembly for coupling a first tubular to a second tubular, comprising:

10

a mandrel coupled to a first tubular and having a longitudinal groove and an arcuate groove; and

a housing coupled to the second tubular and adapted to receive the mandrel, wherein the housing includes a first pin for coupling with the longitudinal groove and a second pin for coupling with the arcuate groove.

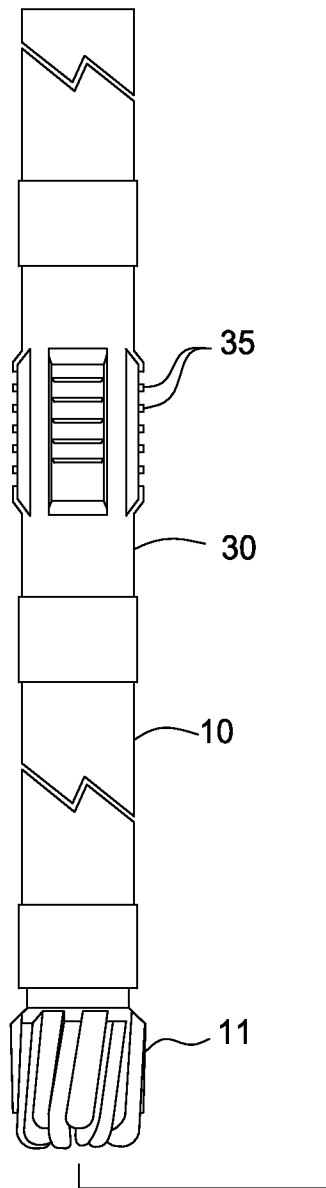

FIG. 1A

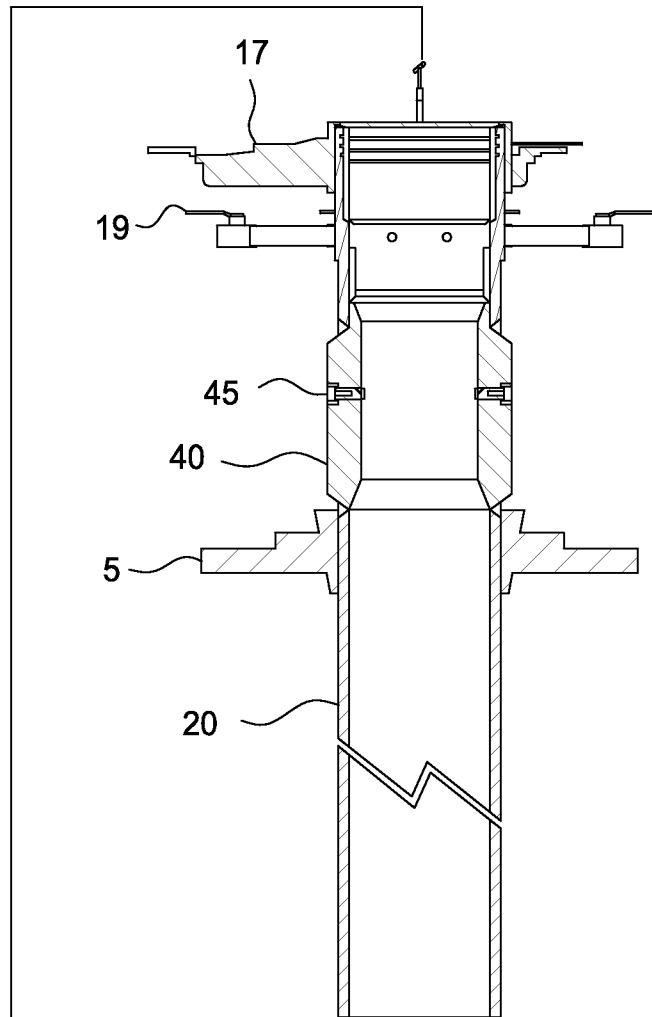

FIG. 1B

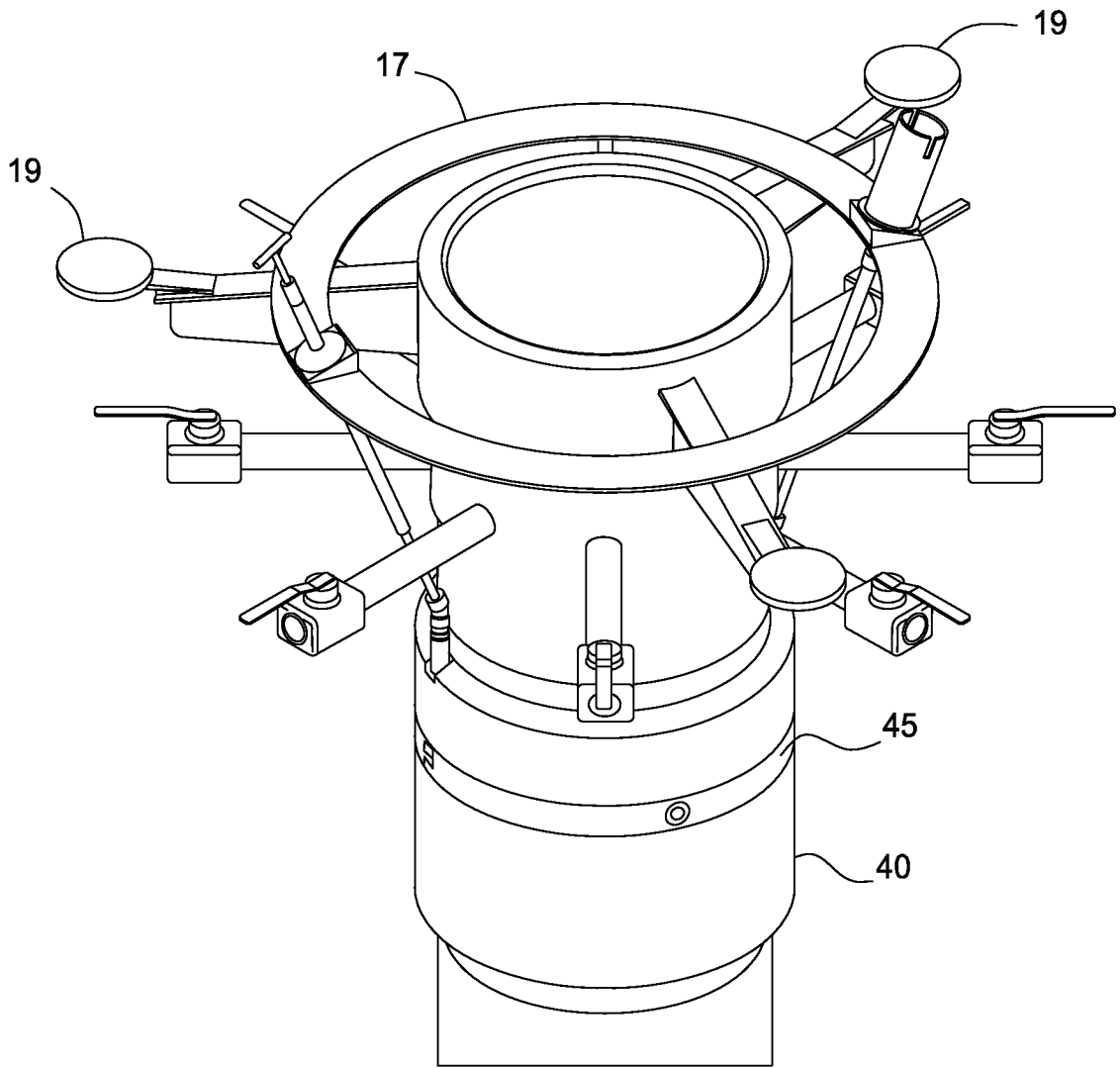

FIG. 2

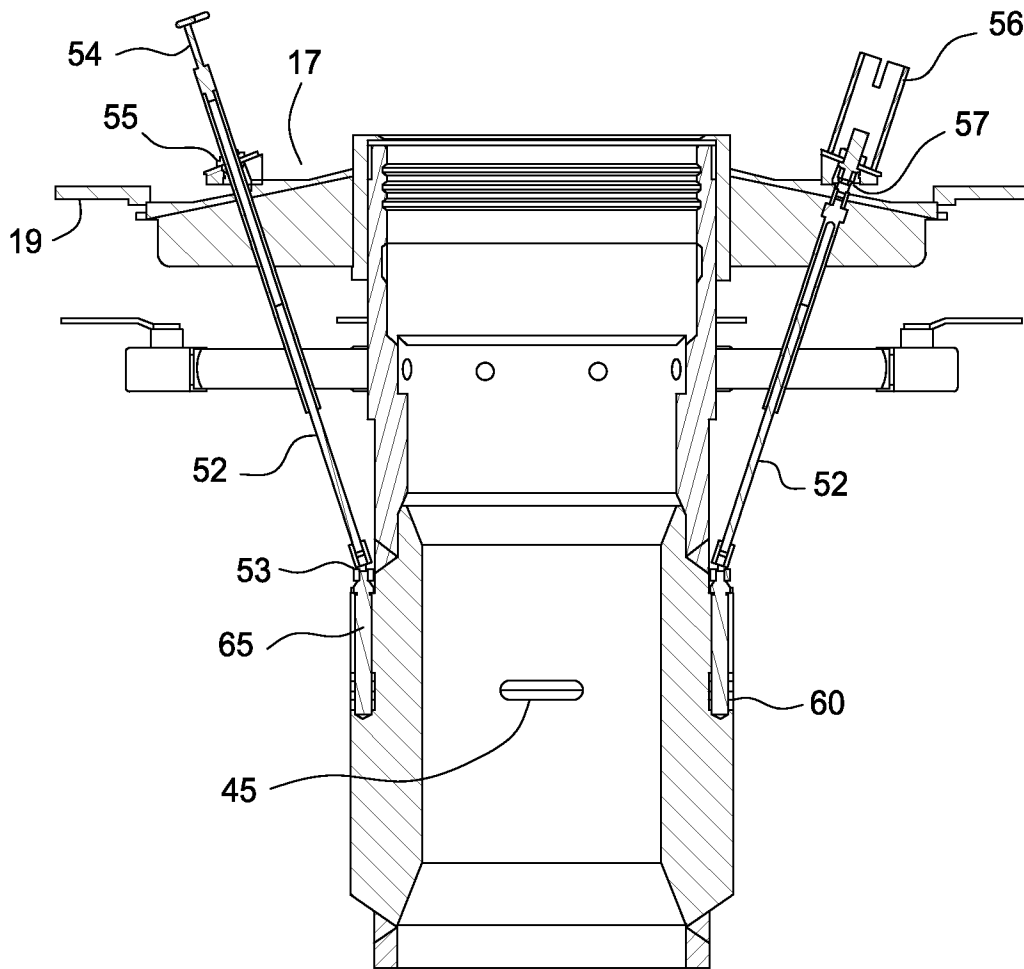

FIG. 3

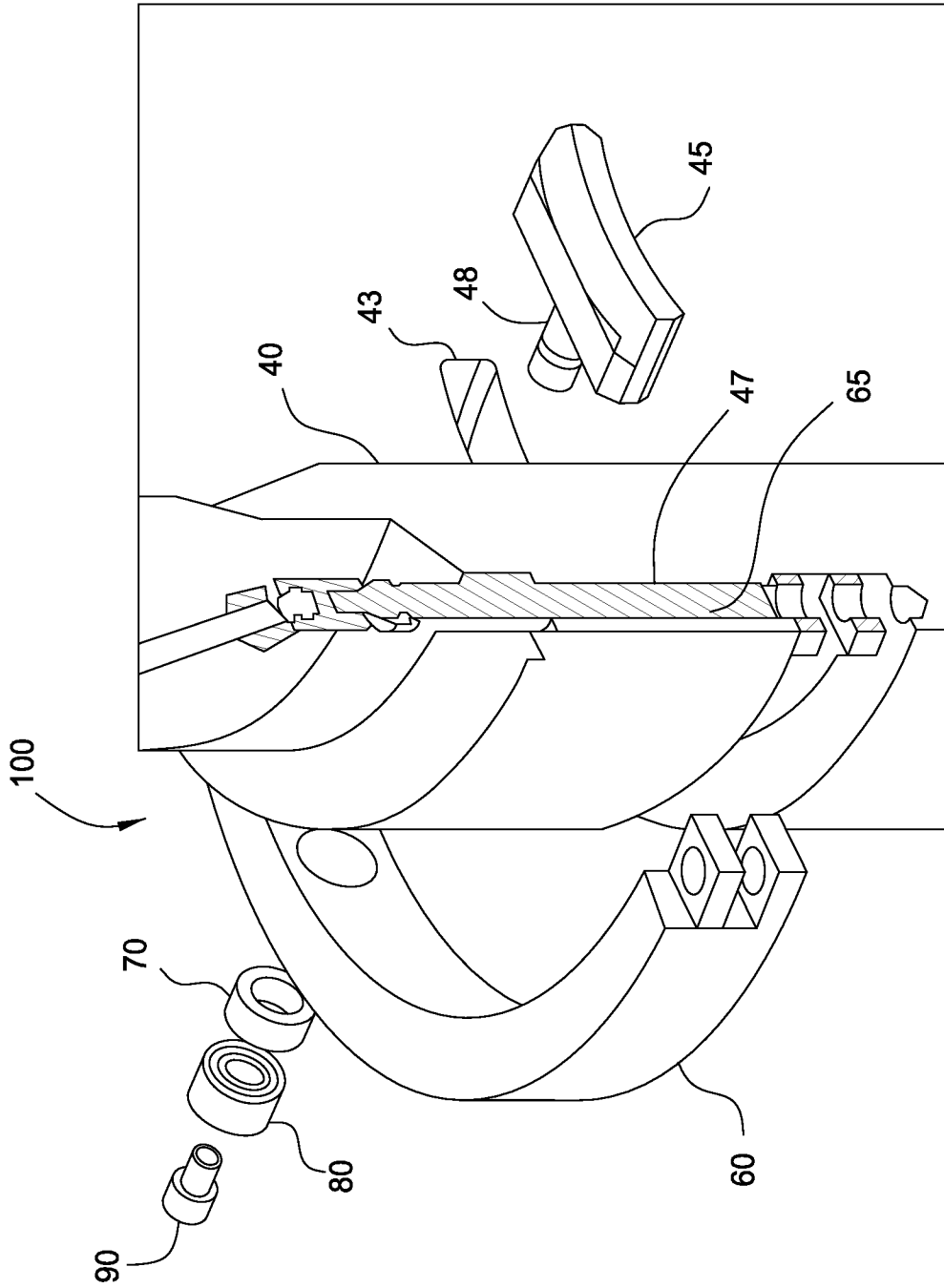

FIG. 4

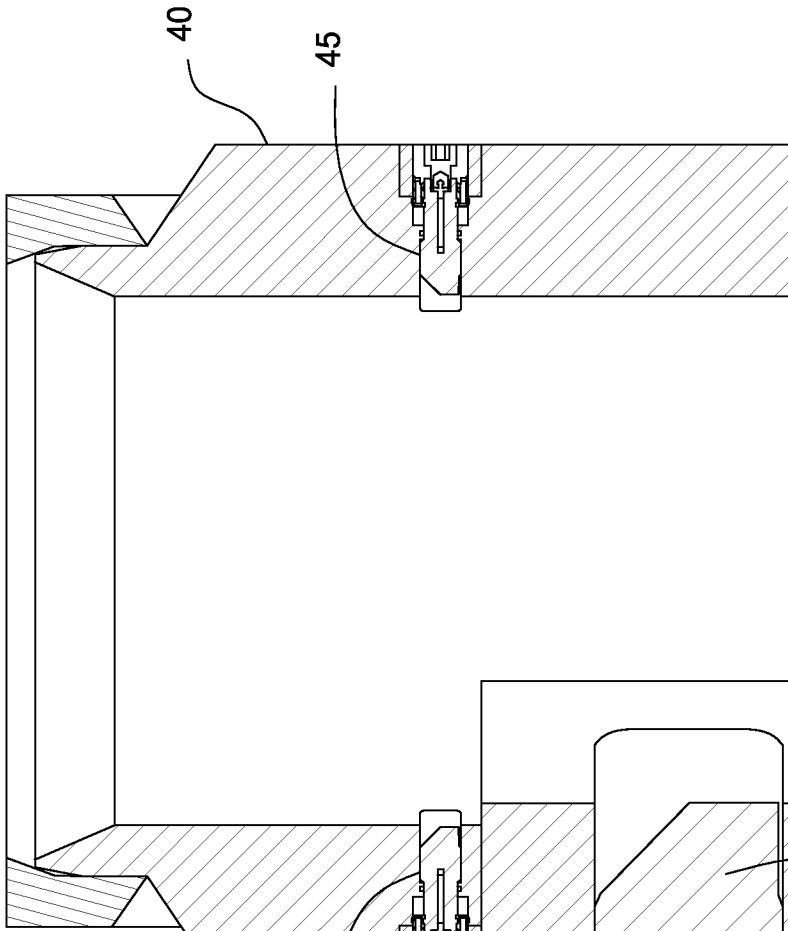

FIG. 5

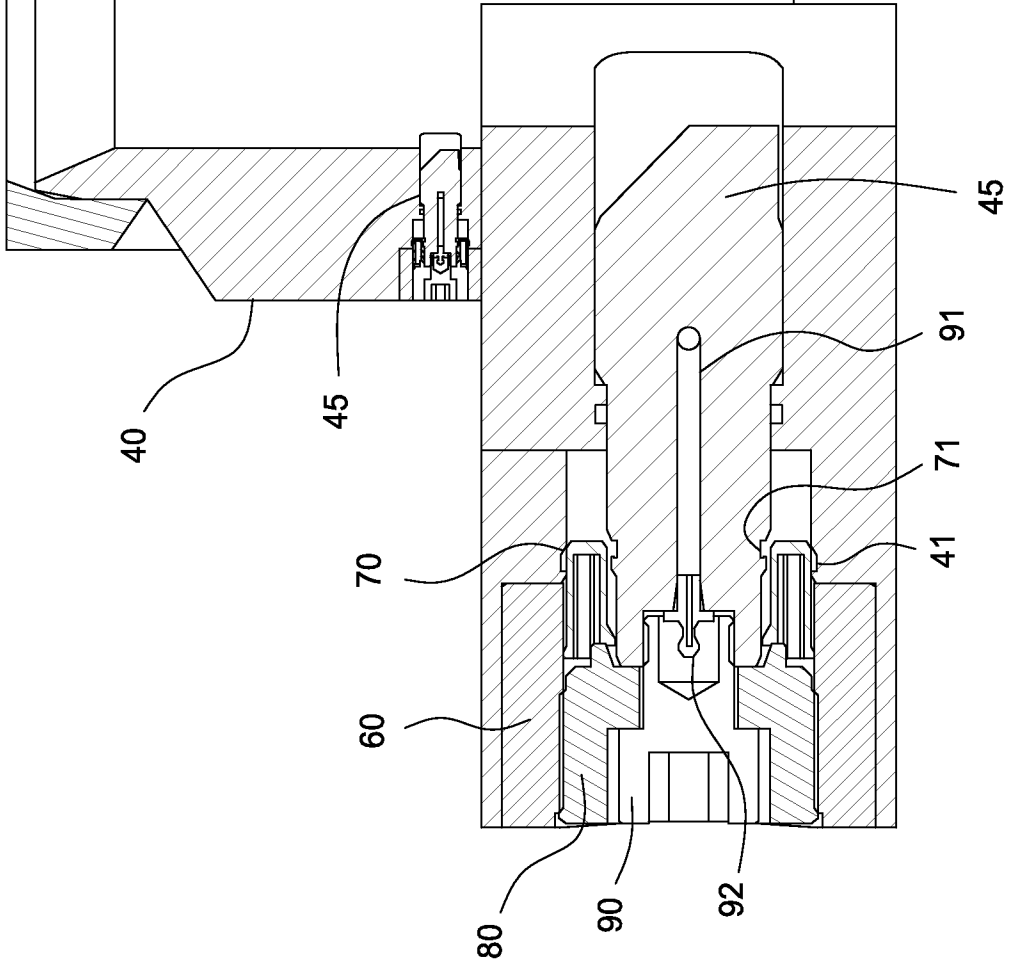

FIG. 6

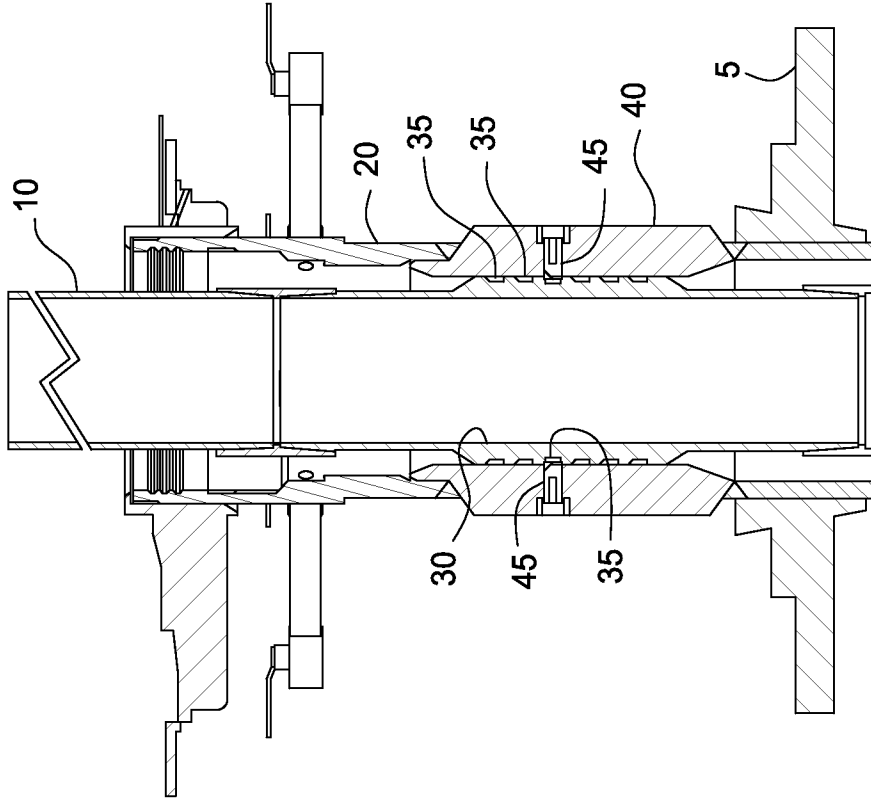

FIG. 7

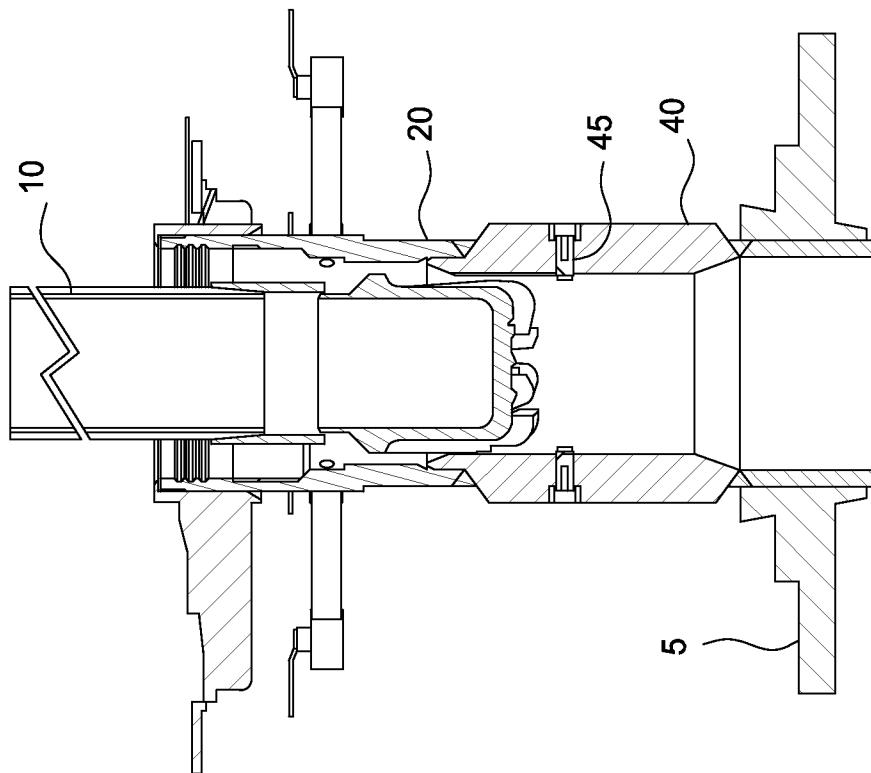

FIG. 8



┌

7/47

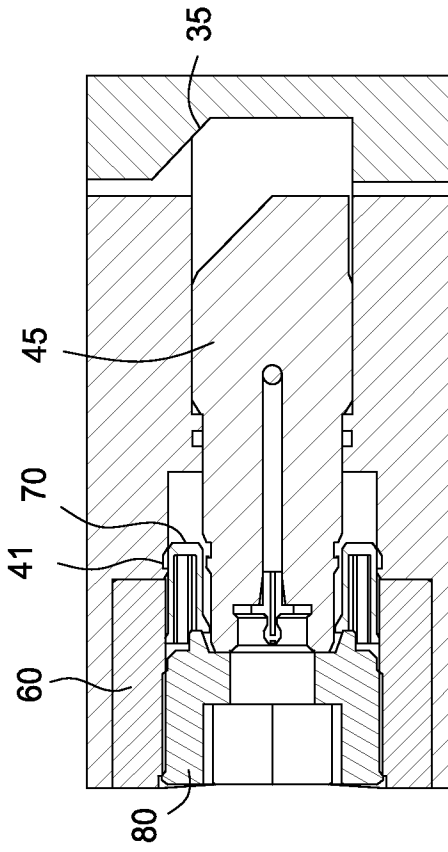

FIG. 10

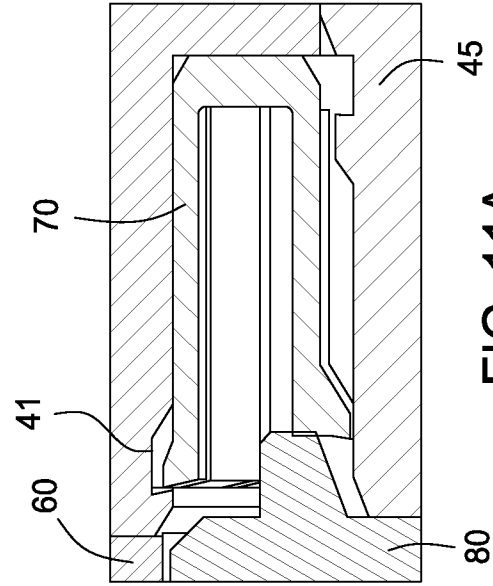

FIG. 11A

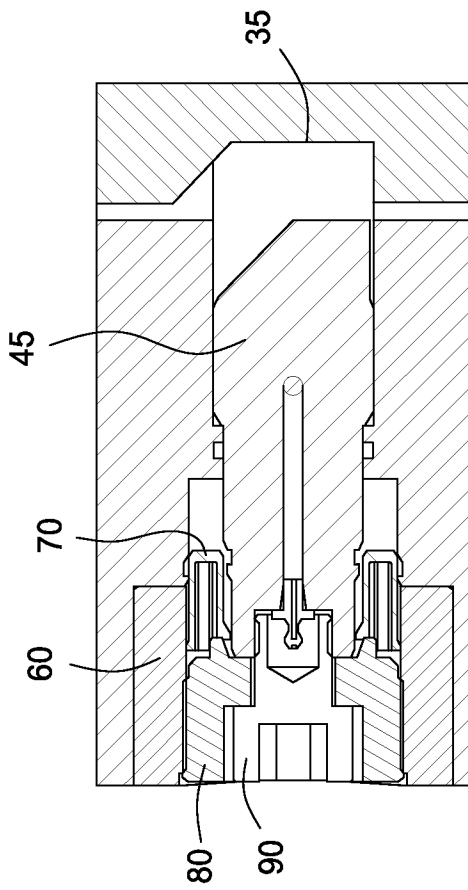

FIG. 9

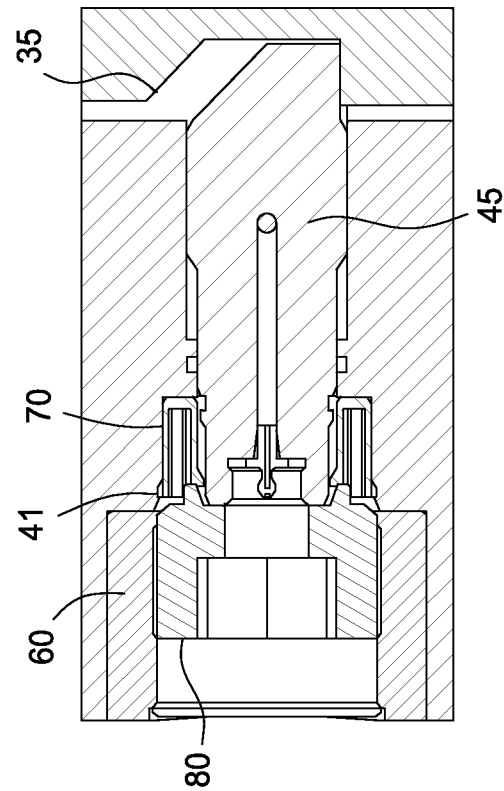

FIG. 11

└

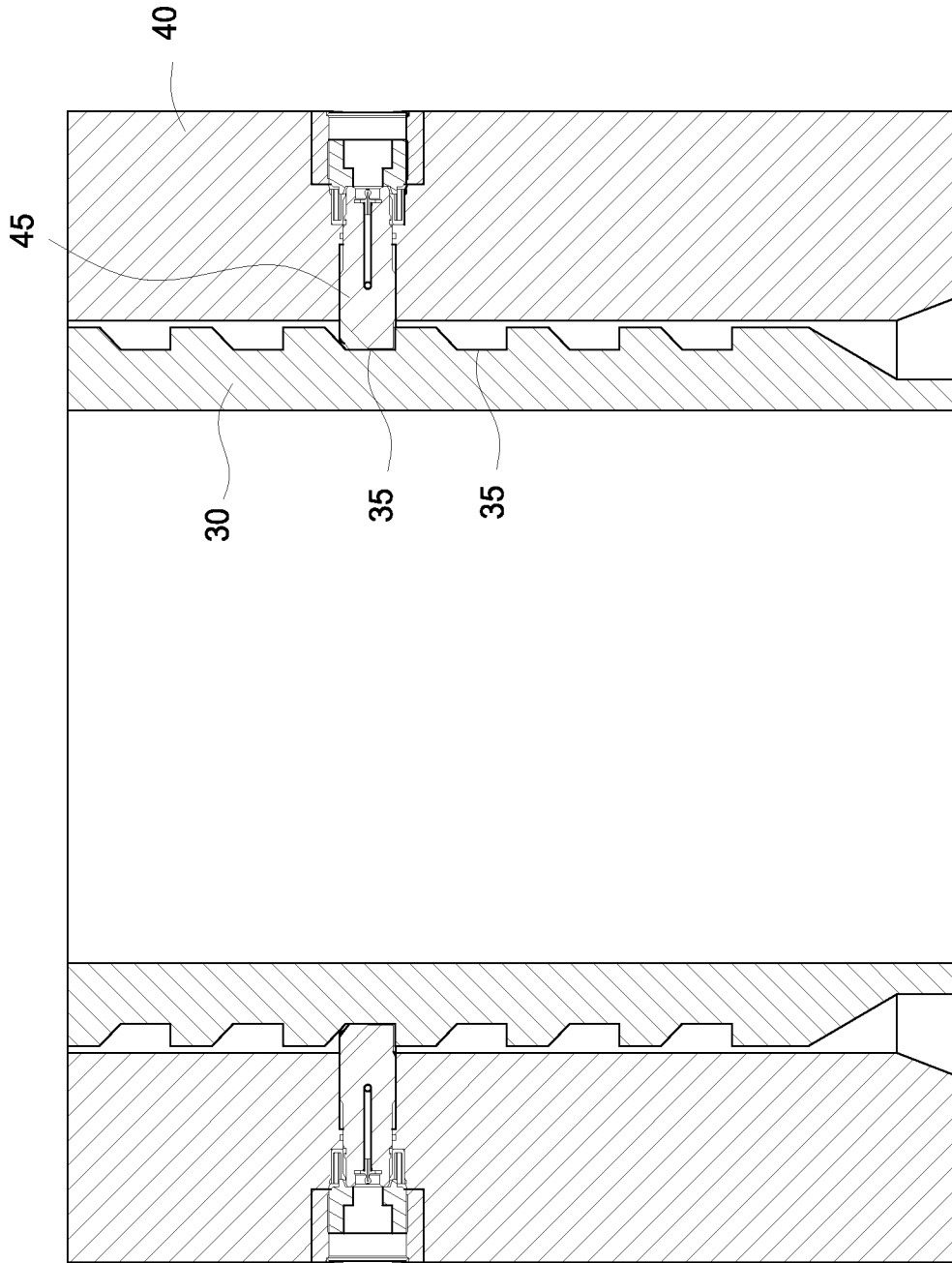

FIG. 12

┌

9/47

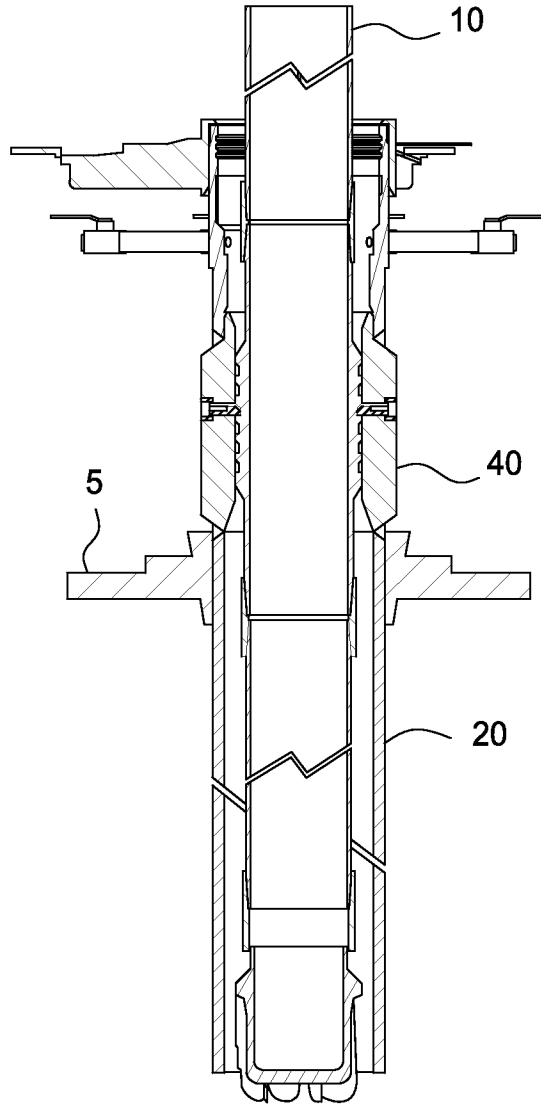

FIG. 13

└

10/47

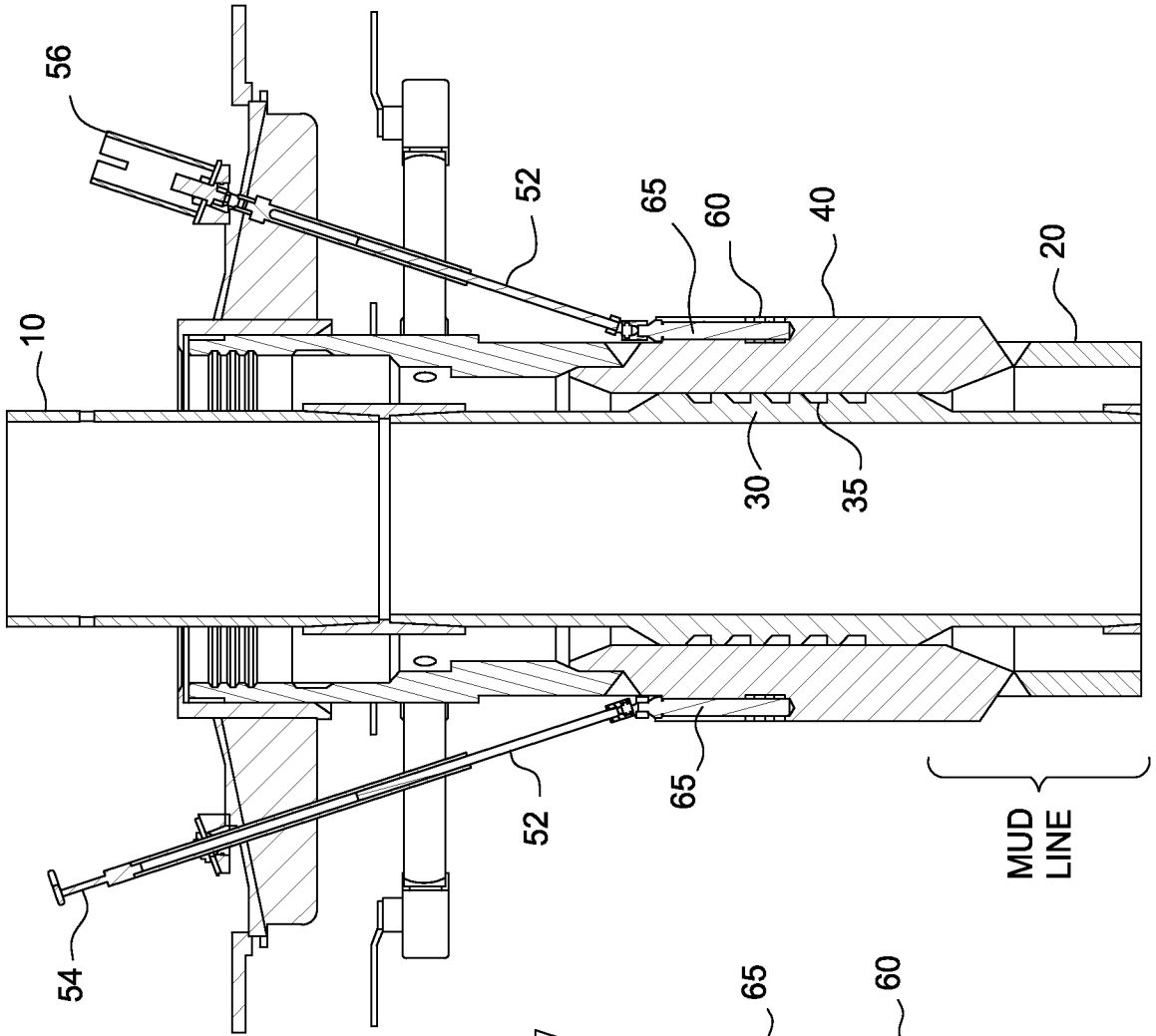

FIG. 14

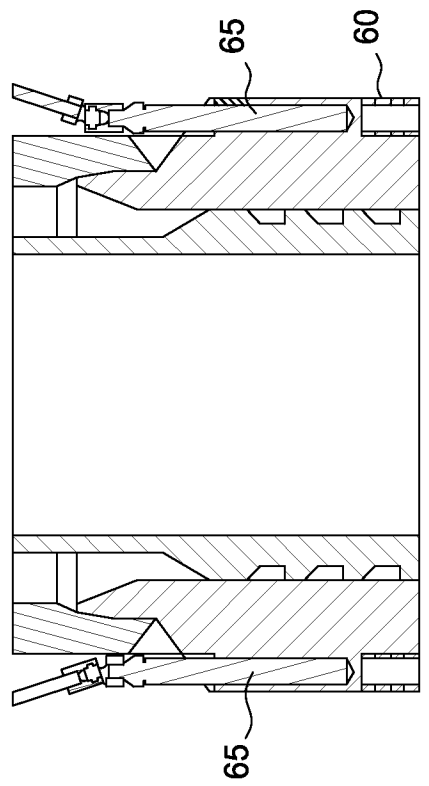

FIG. 14A

11/47

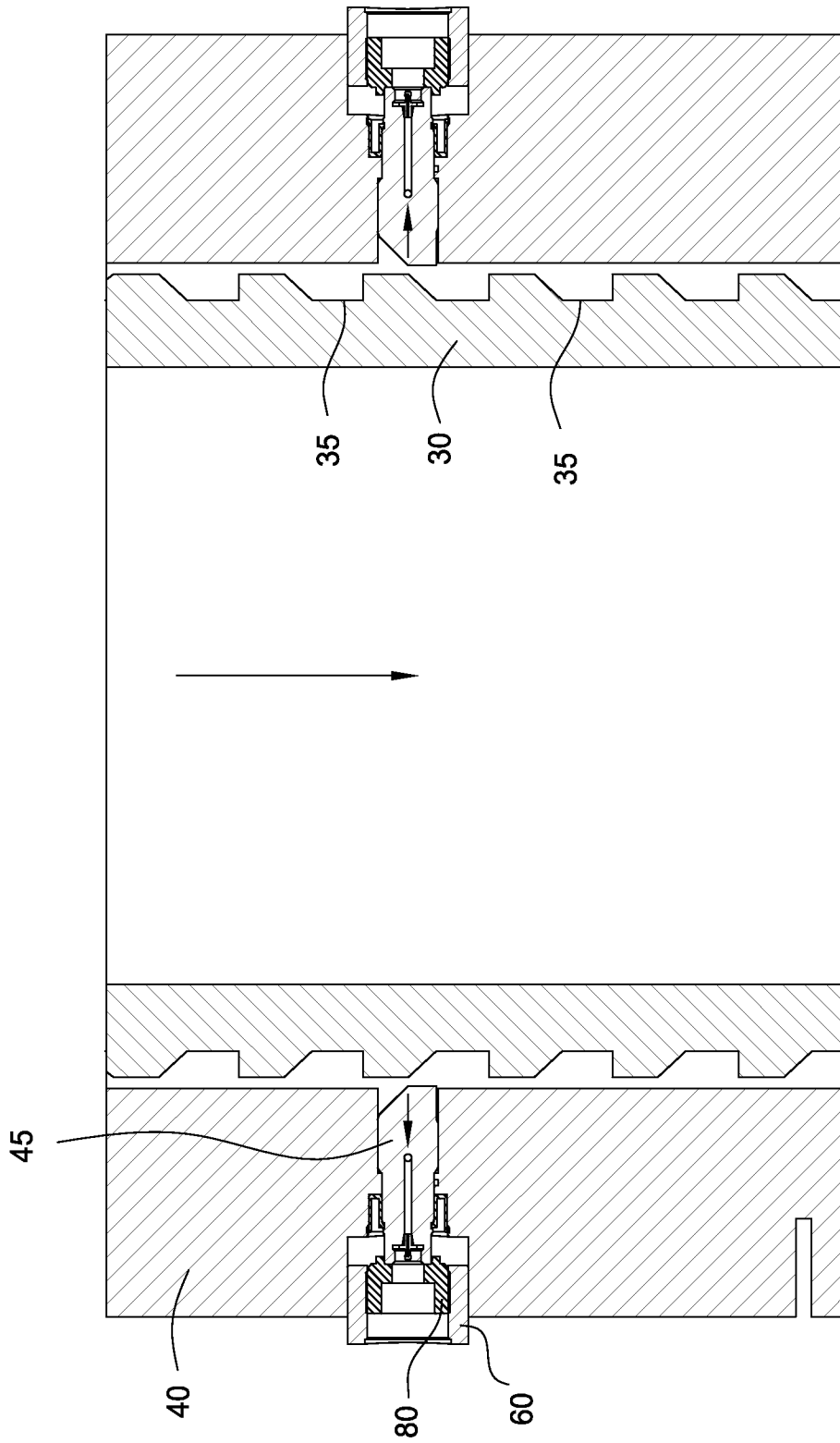

FIG. 15



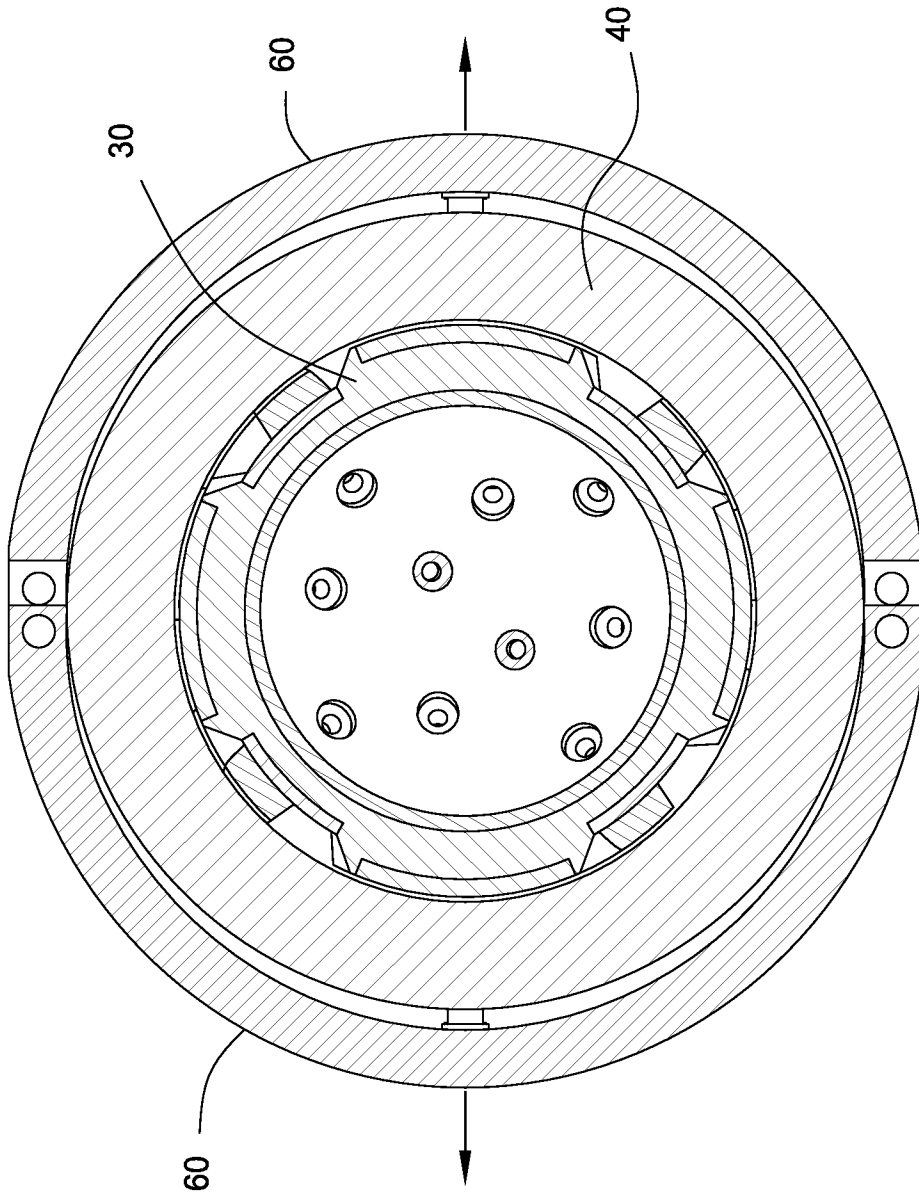

FIG. 16

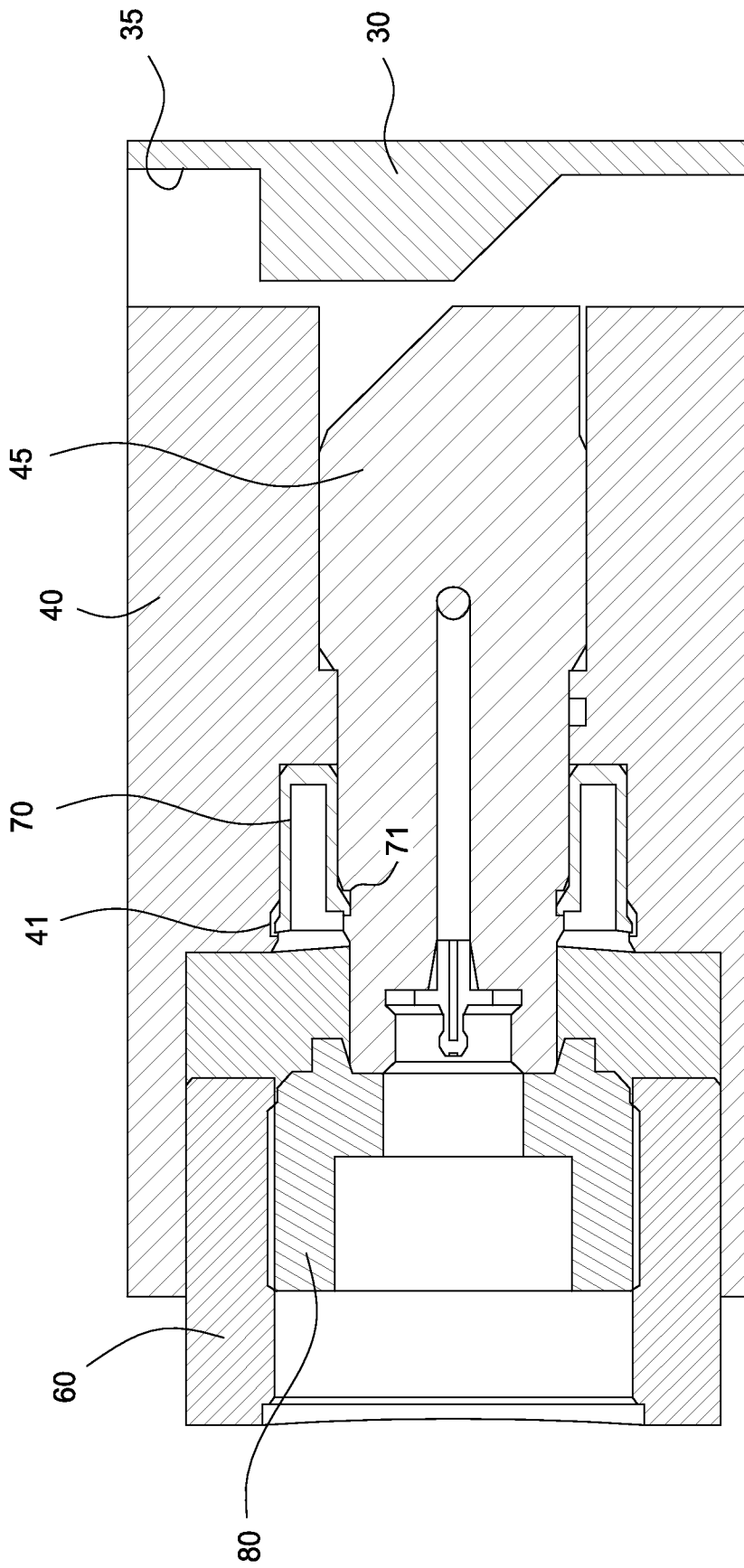

FIG. 17

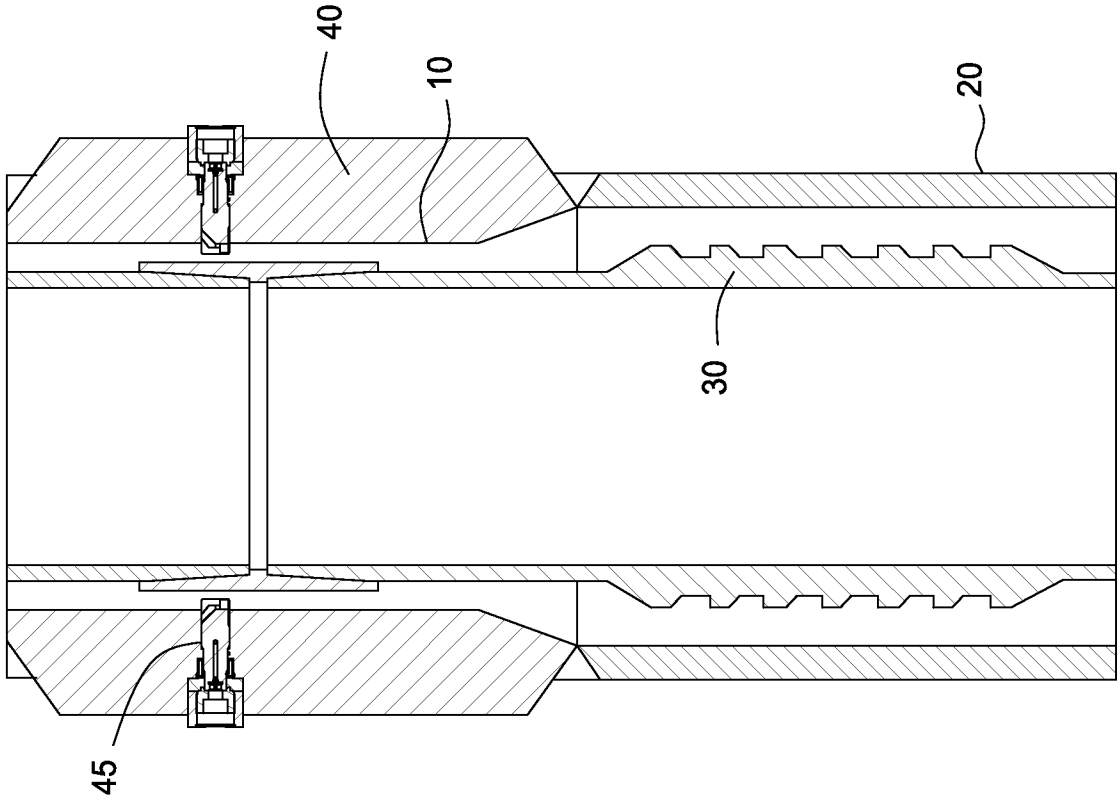

FIG. 18A

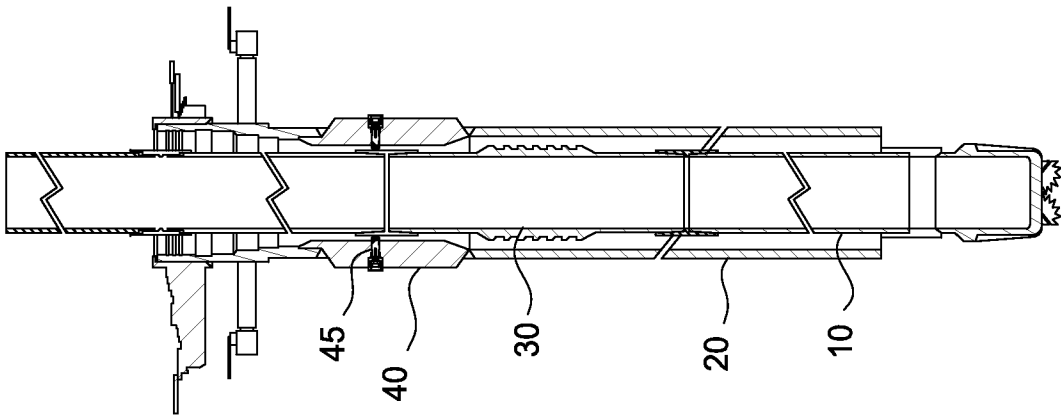

FIG. 18





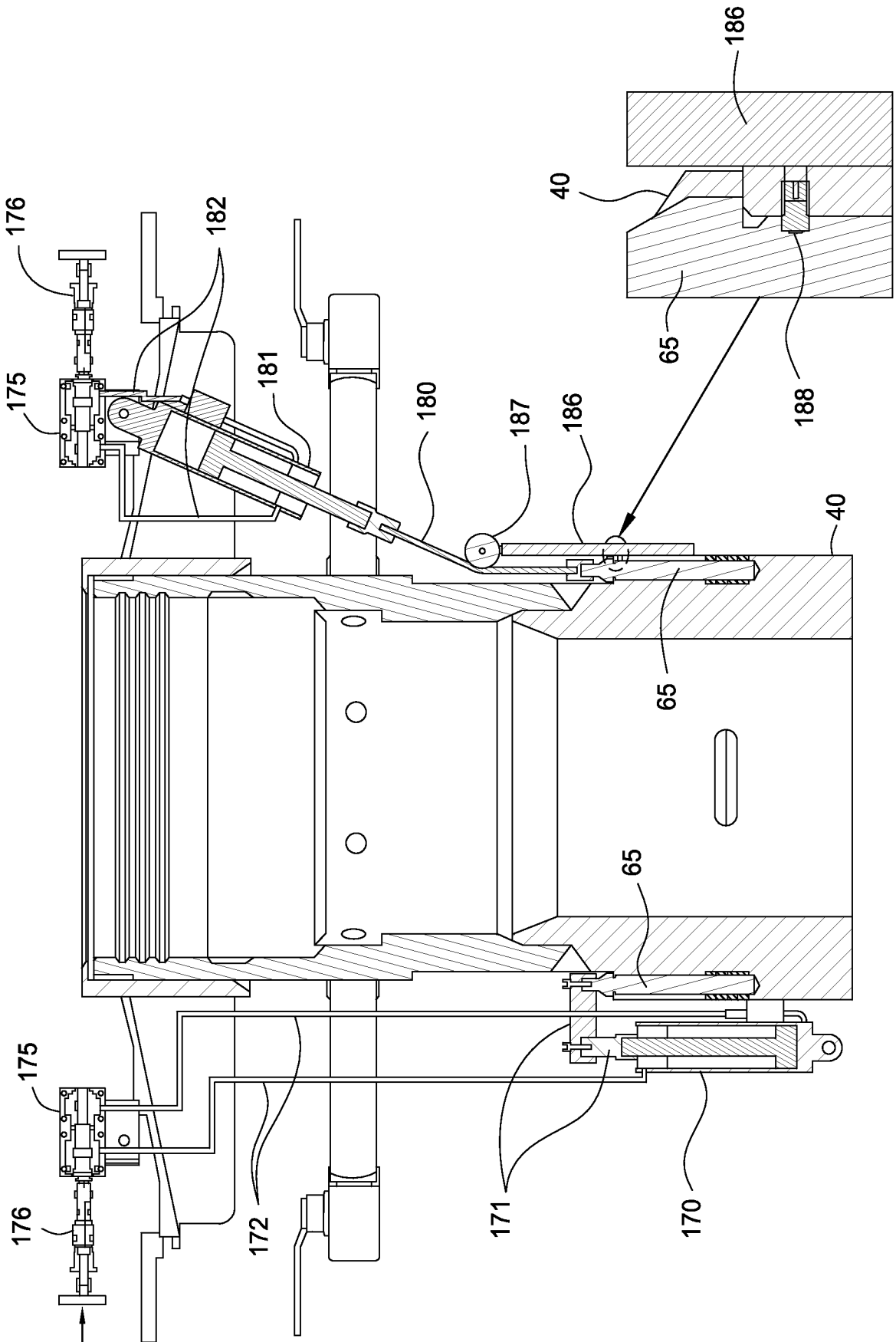

FIG. 19



┌

16/47

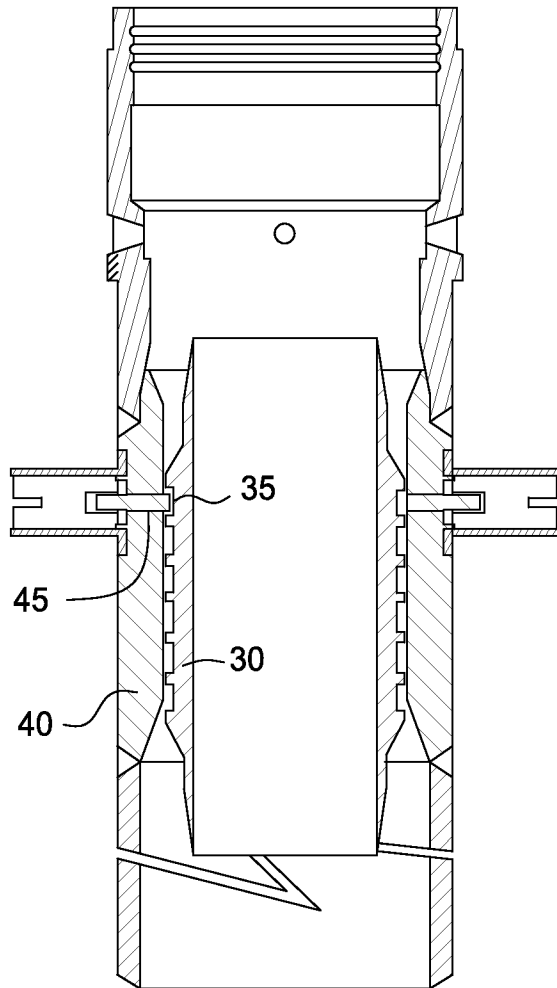

FIG. 20

└

17/47

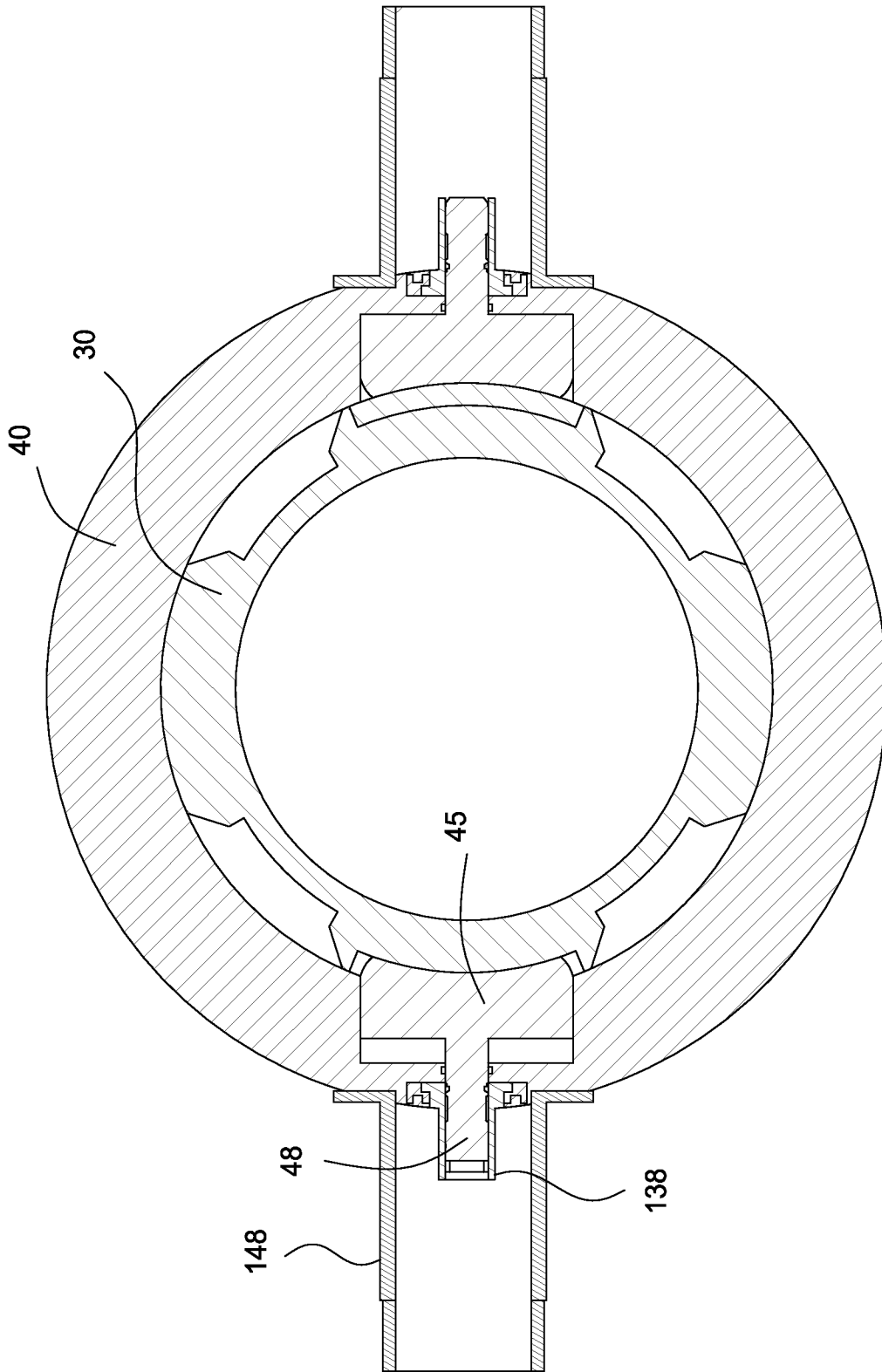

FIG. 21

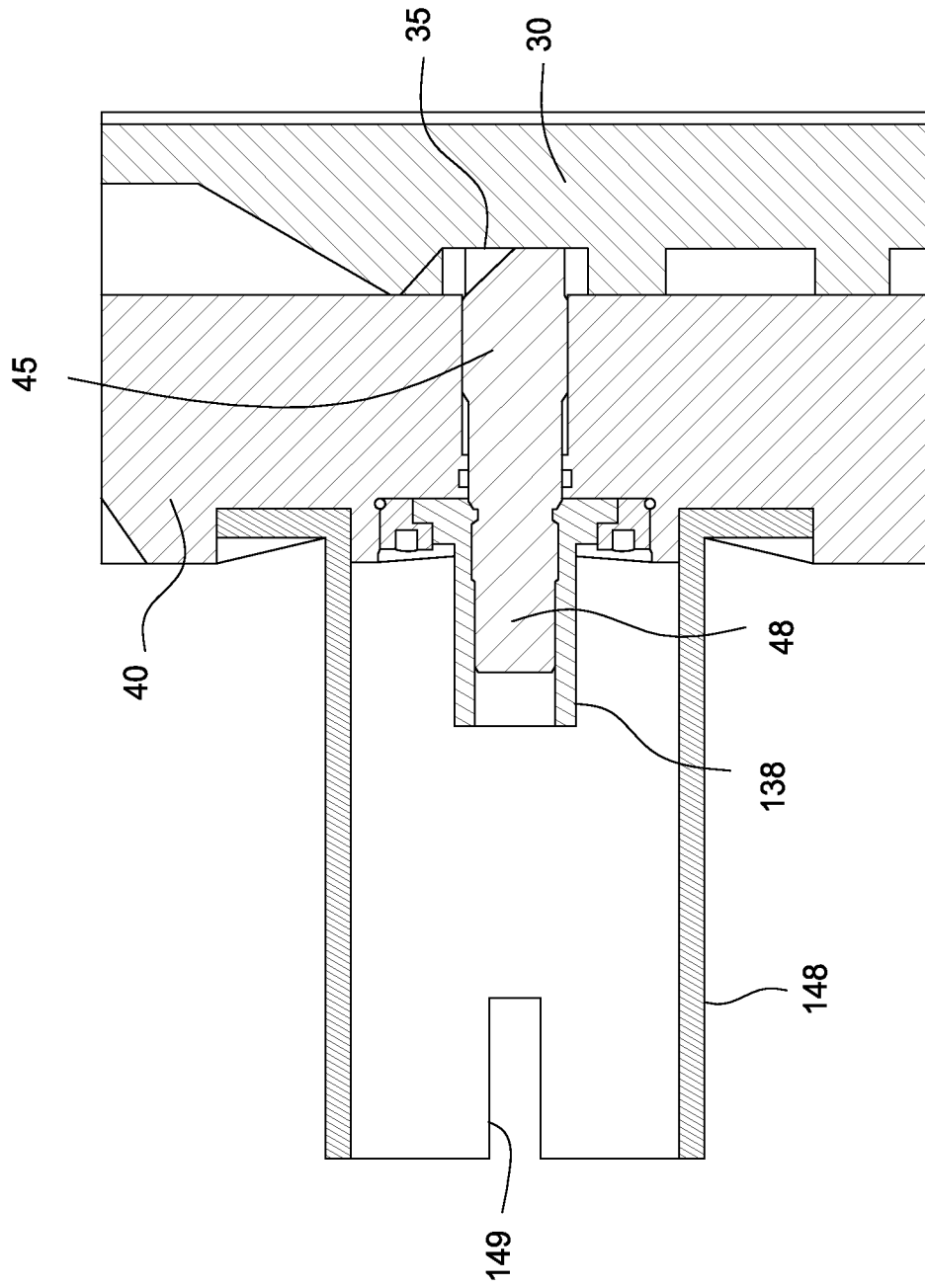

FIG. 22

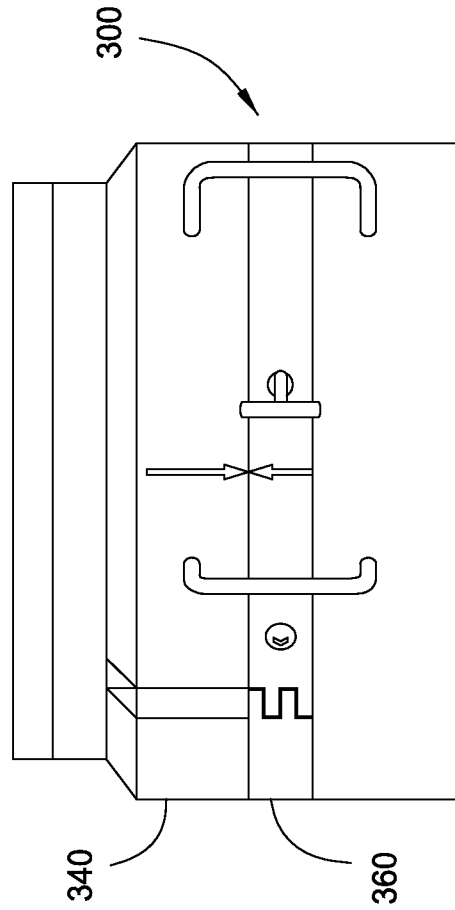

FIG. 23

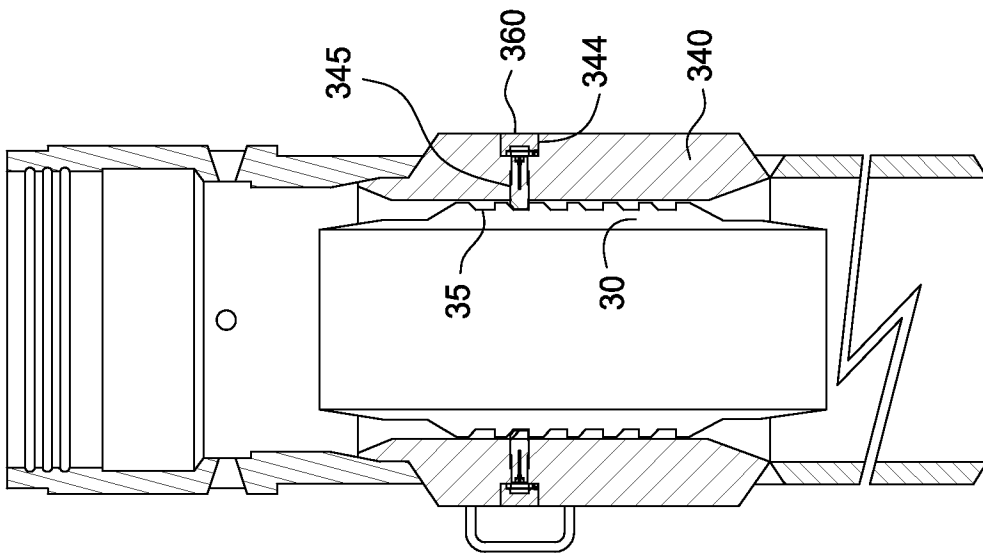

FIG. 24



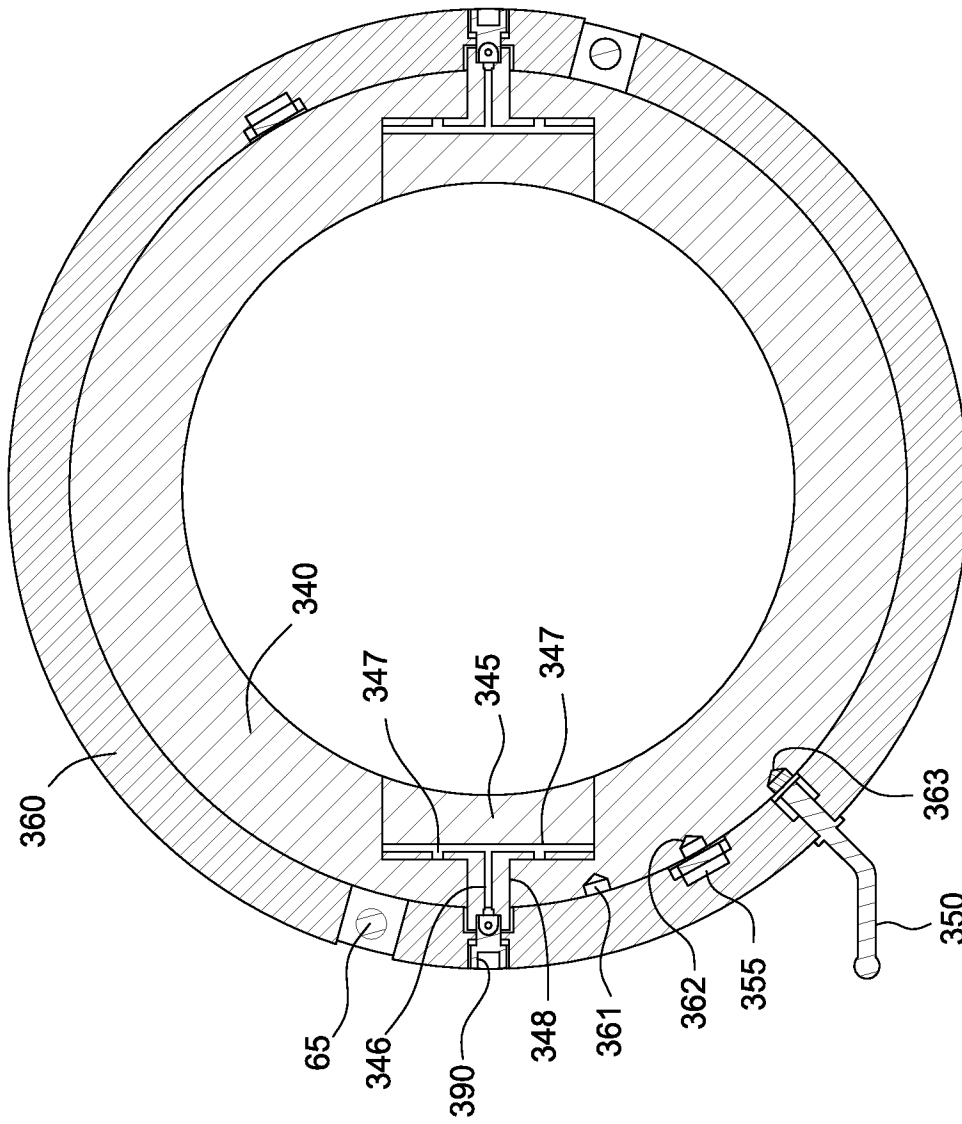

FIG. 25



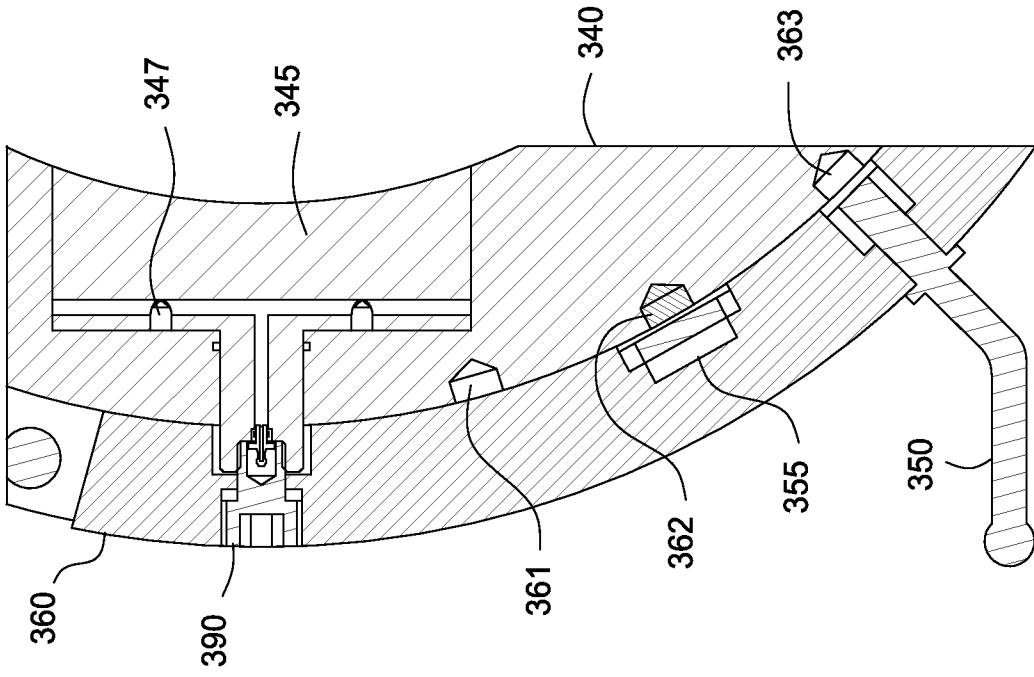

FIG. 26

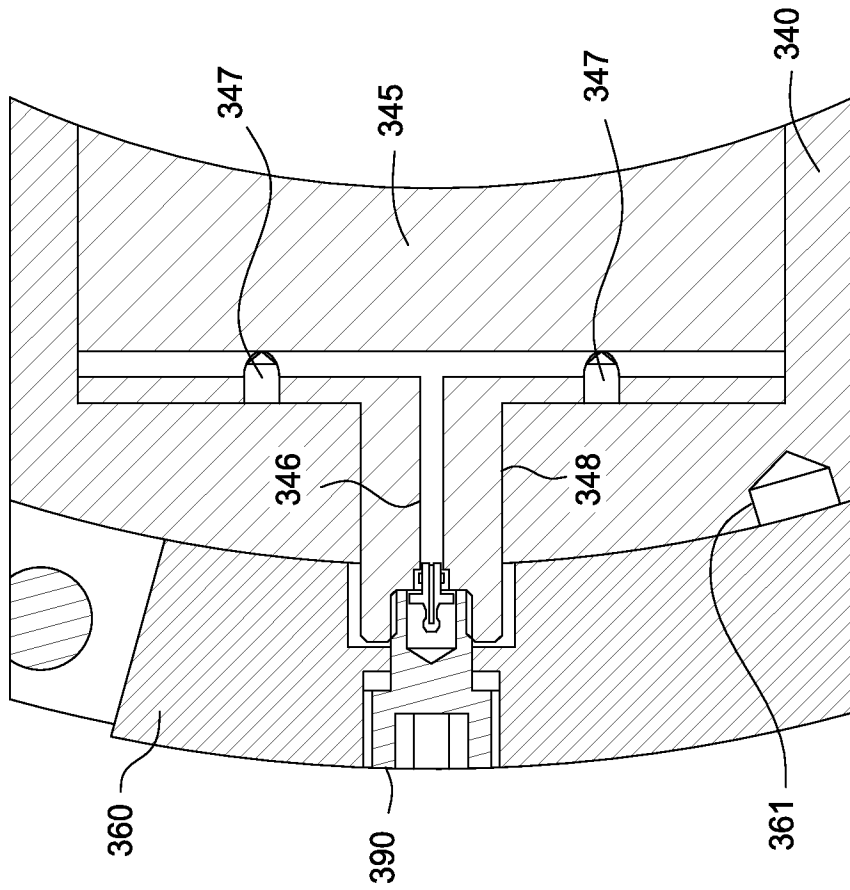

FIG. 26A



22/47

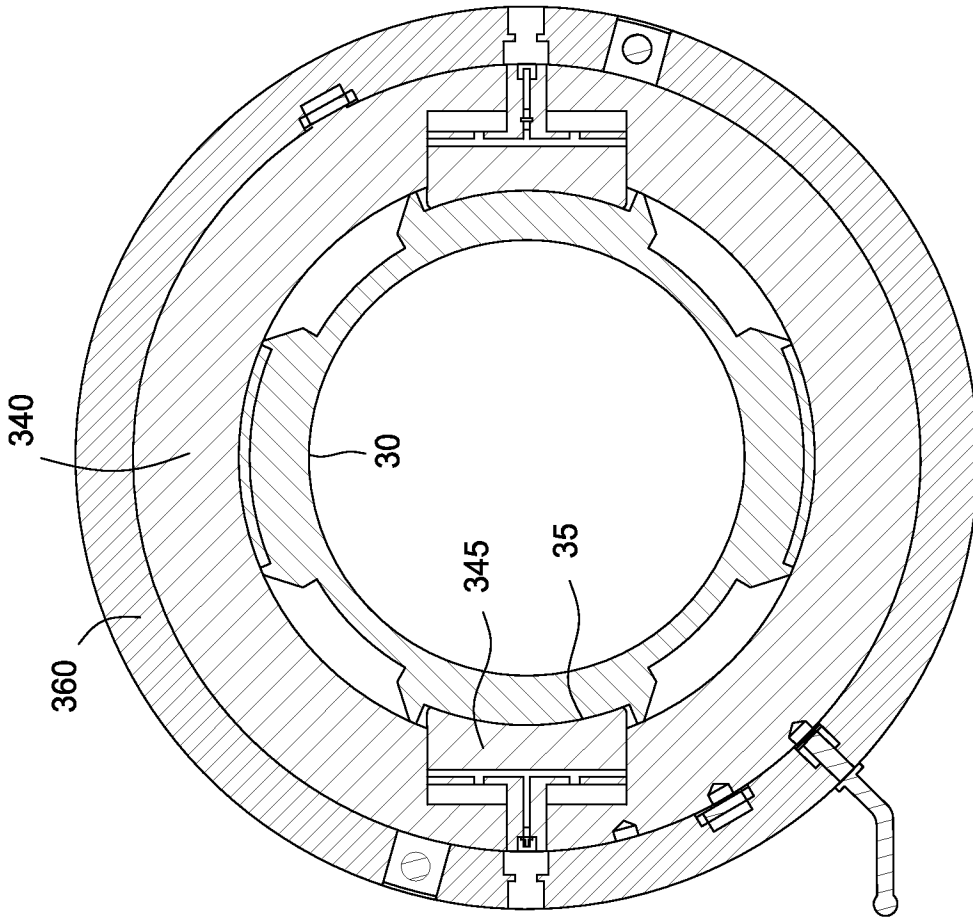

FIG. 27

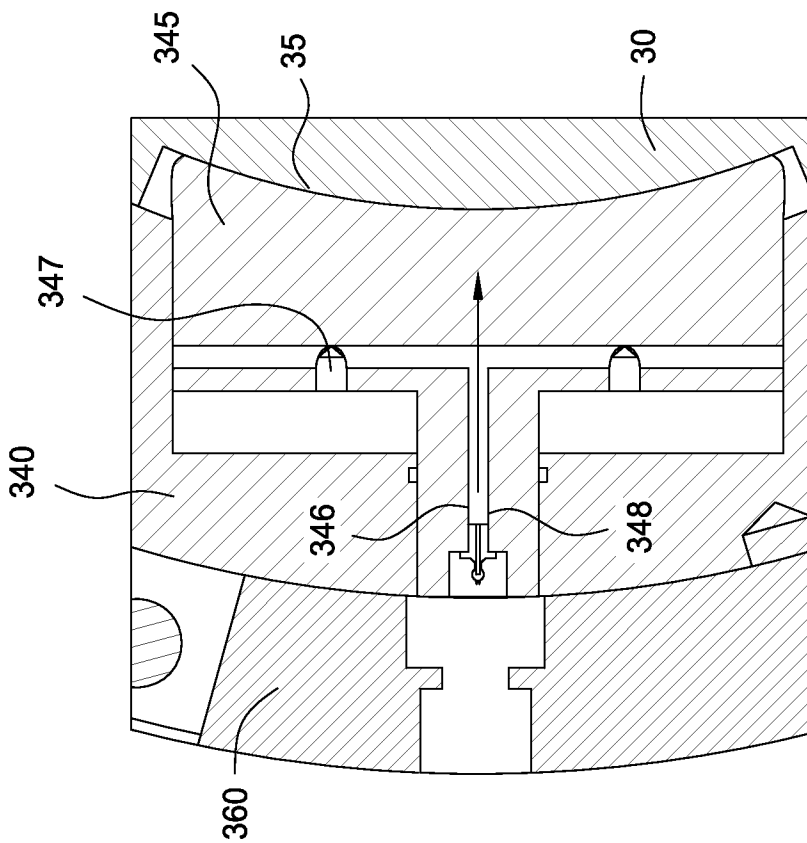

FIG. 27A



23/47

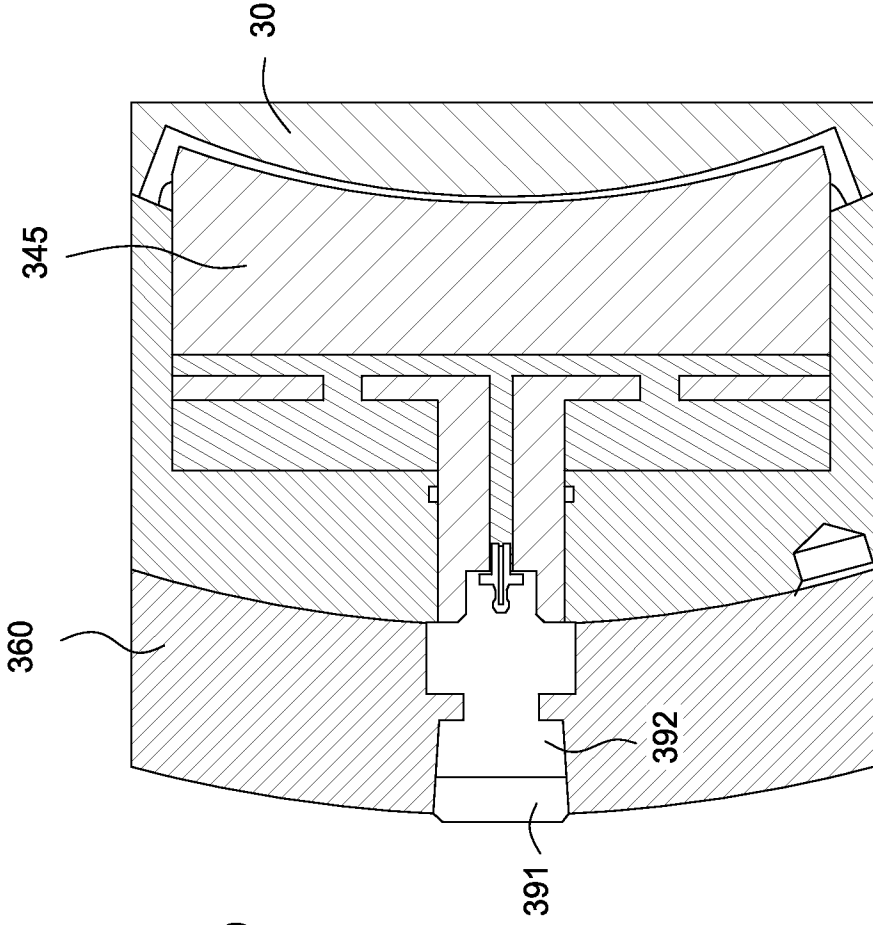

FIG. 28A

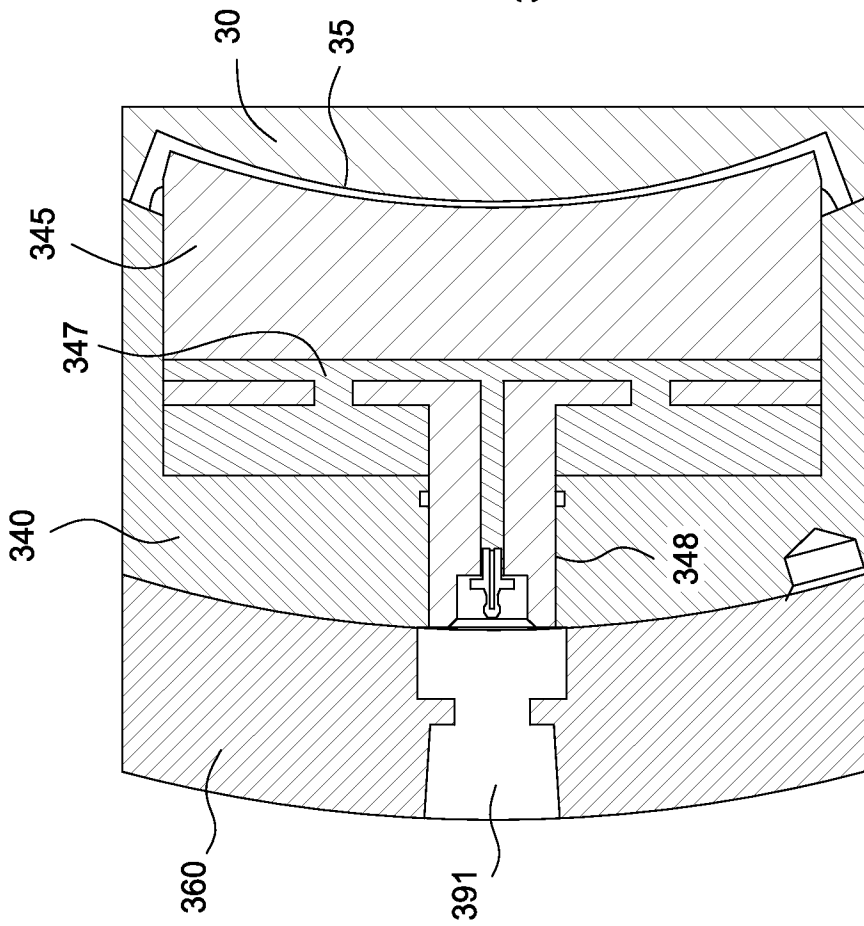

FIG. 28



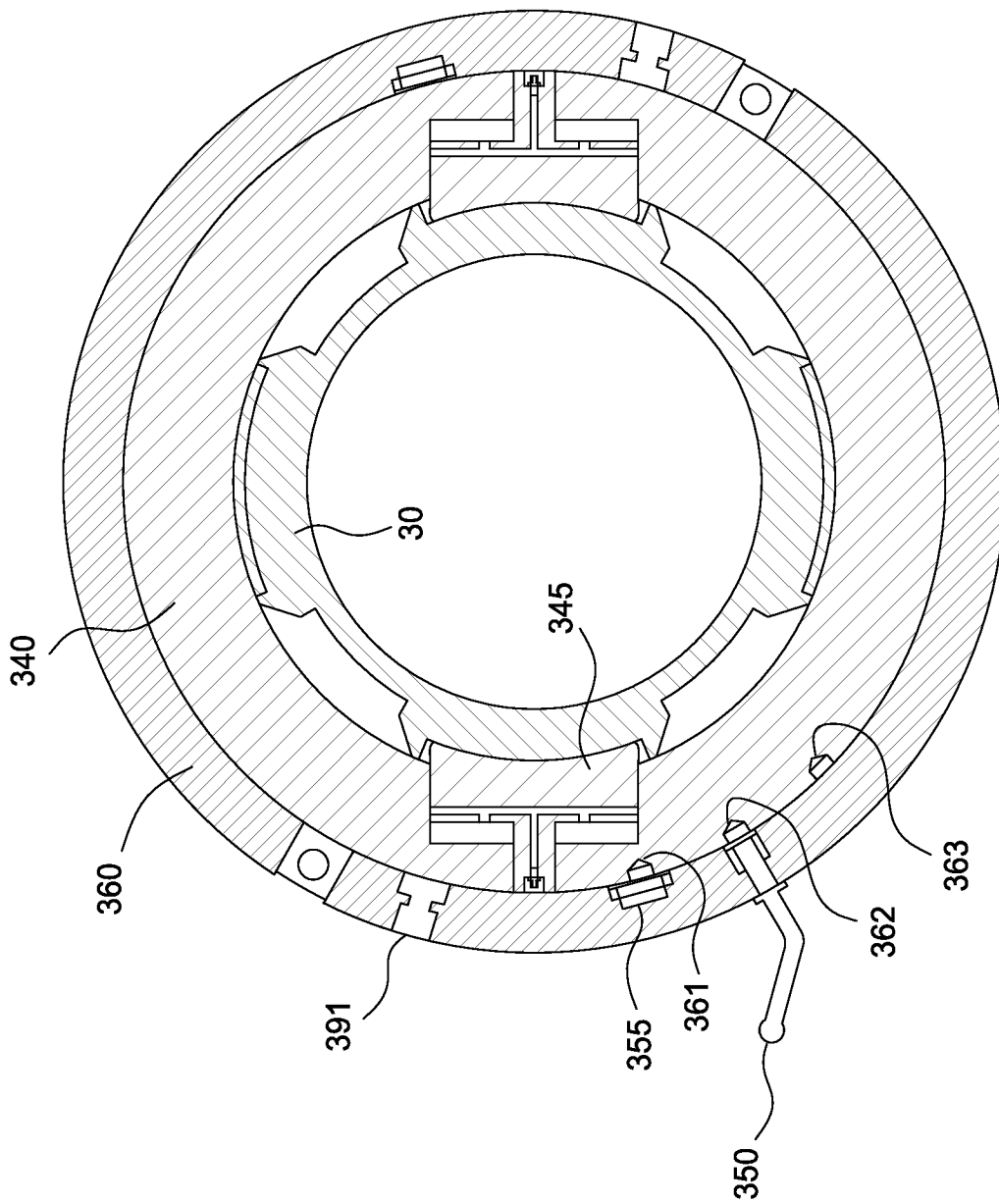

FIG. 29



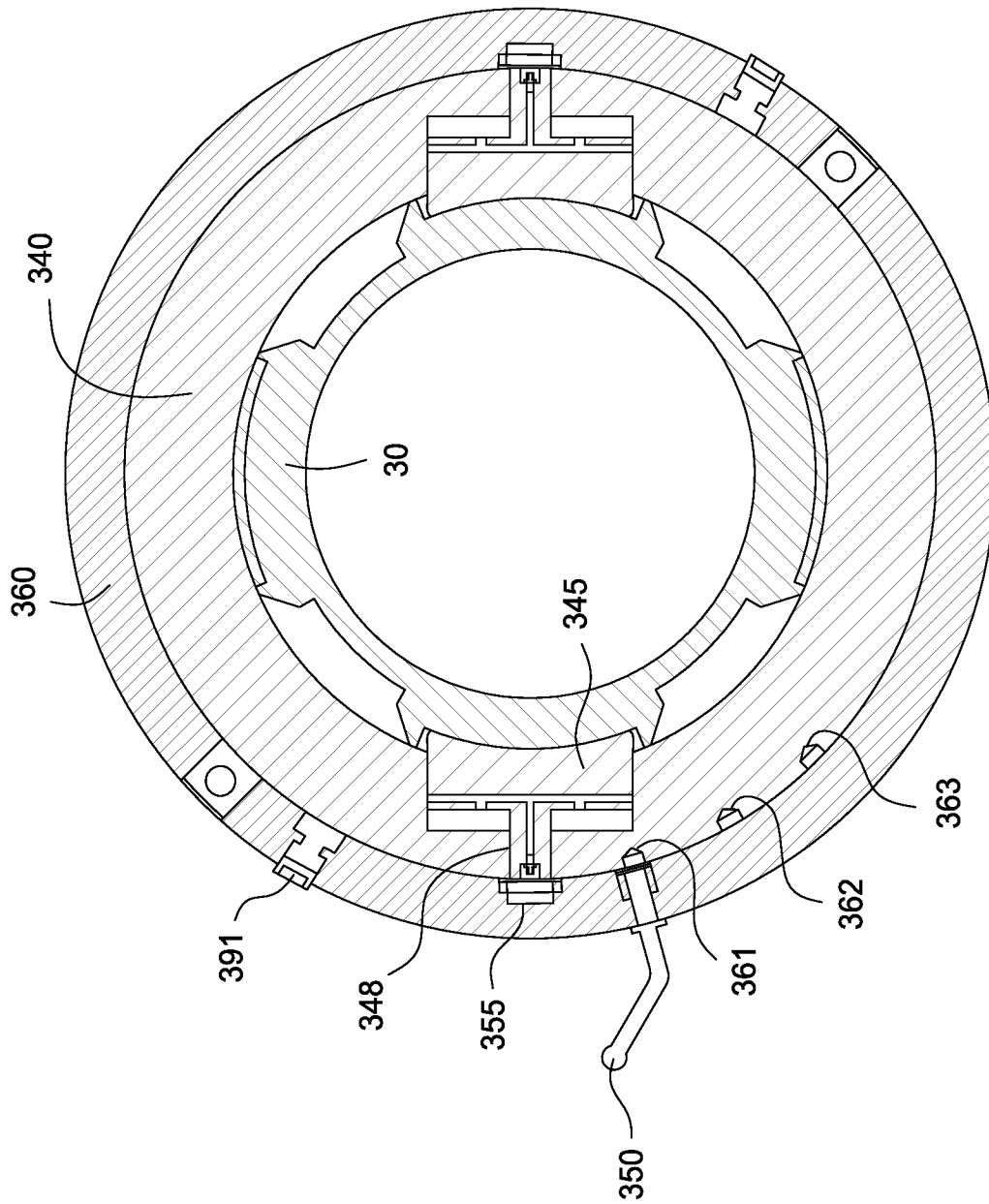

FIG. 30



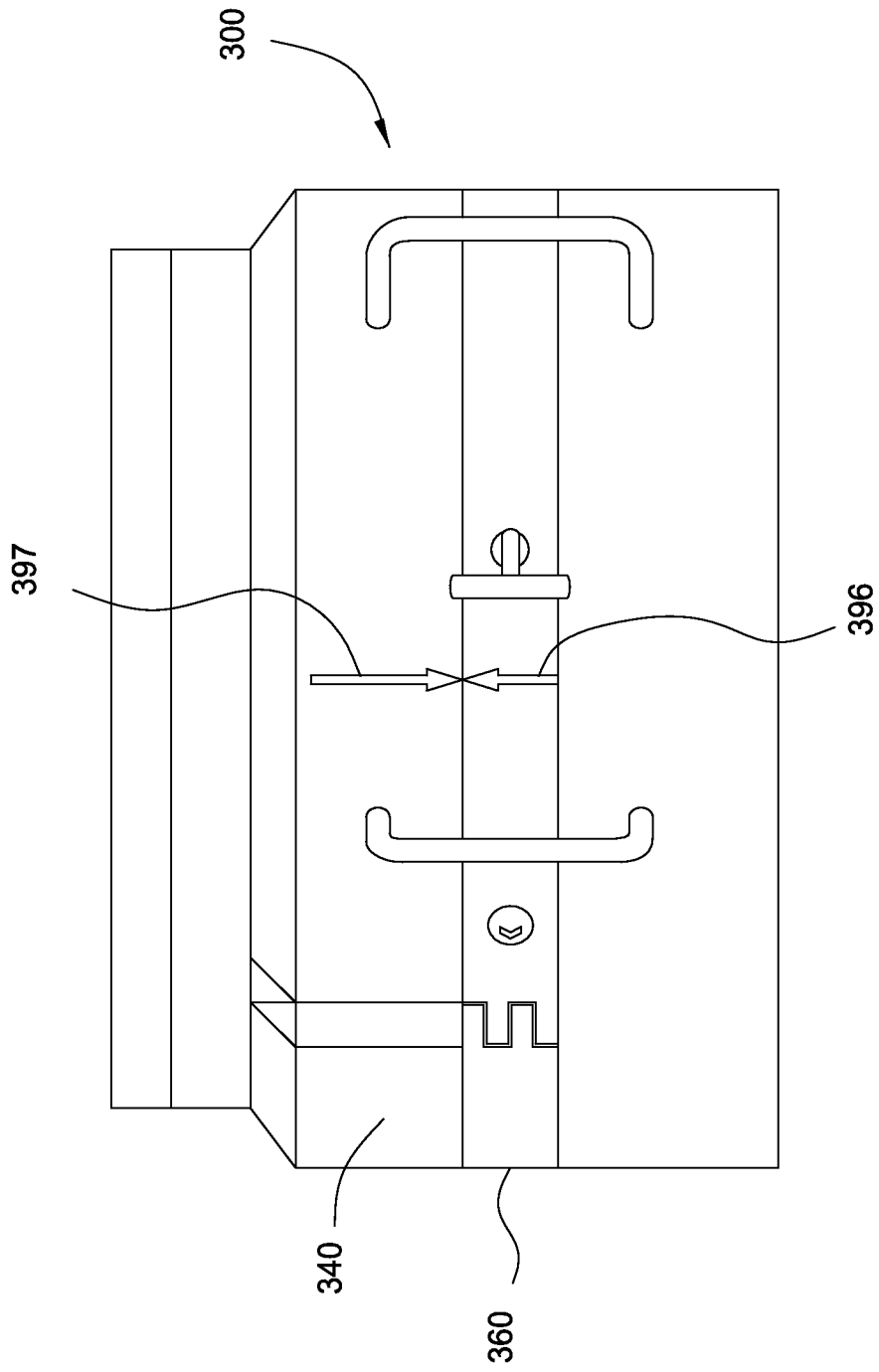

FIG. 31

27/47

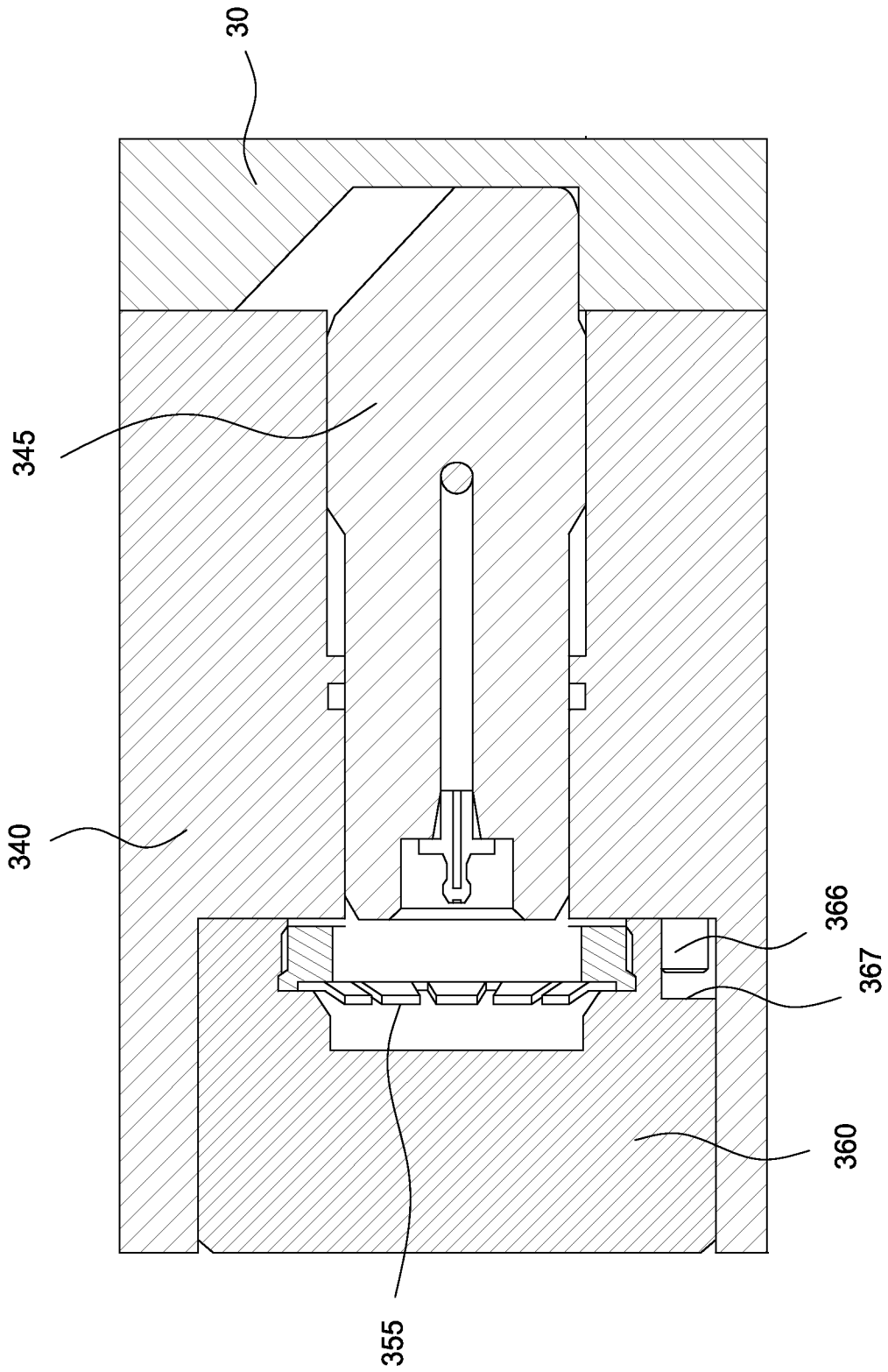

FIG. 32



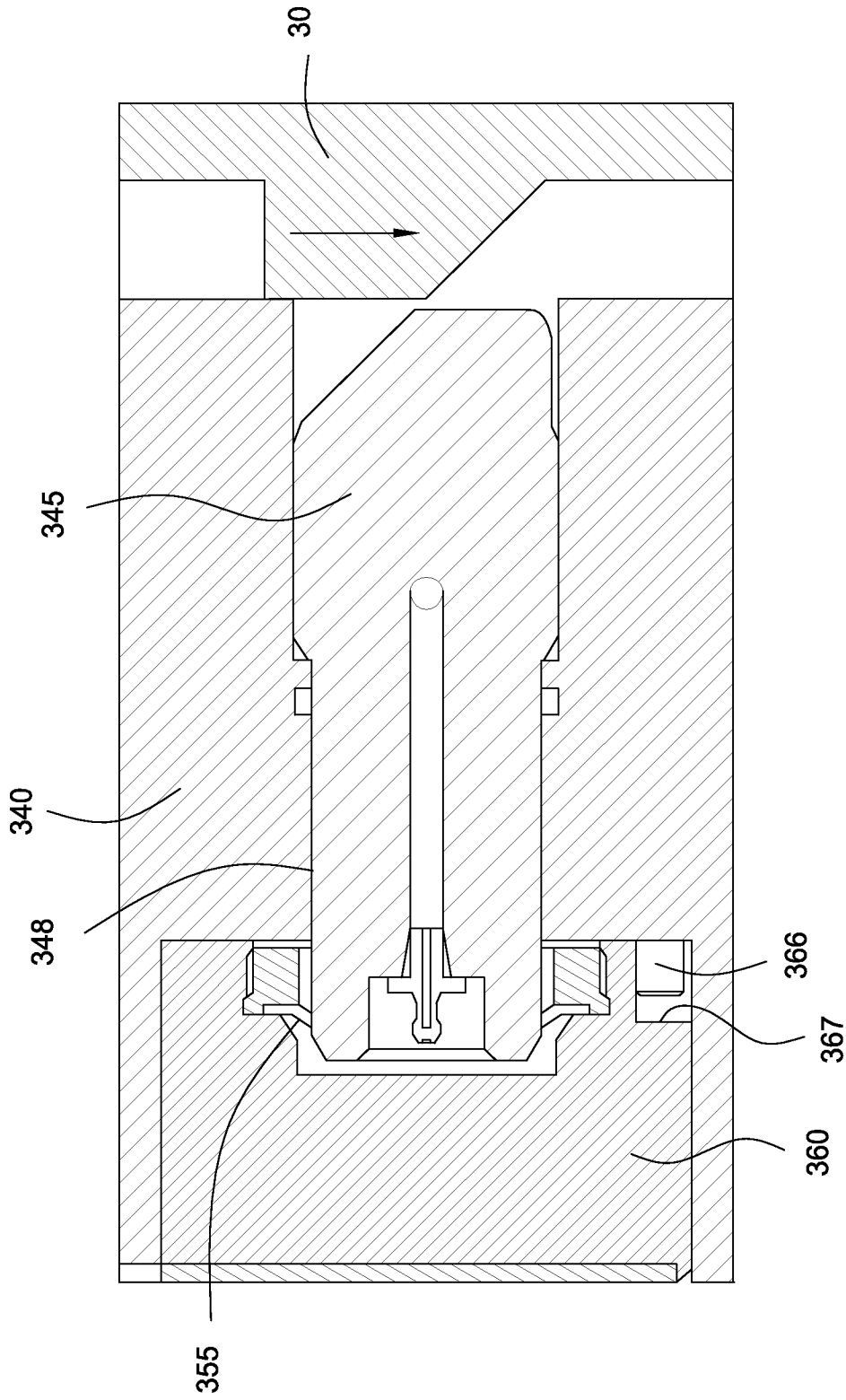

FIG. 33

┌

29/47

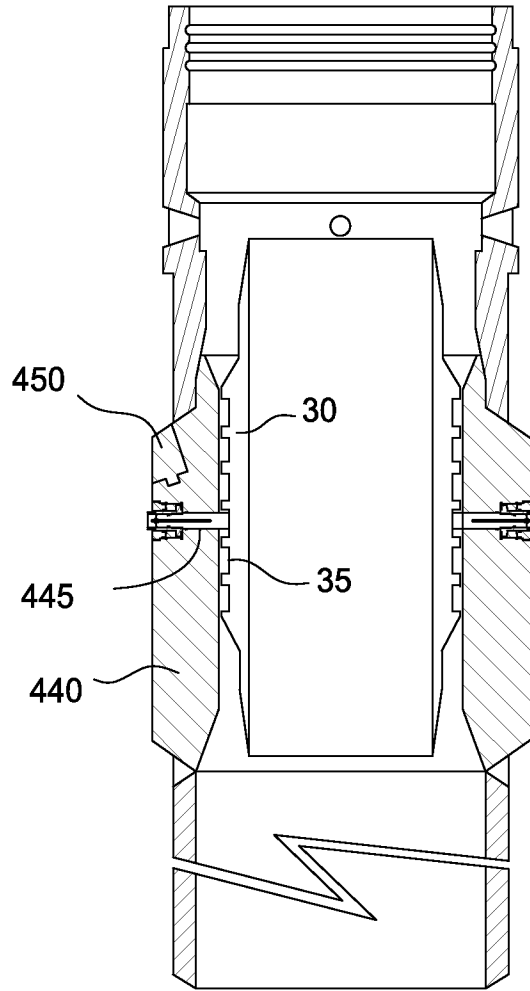

FIG. 34

└

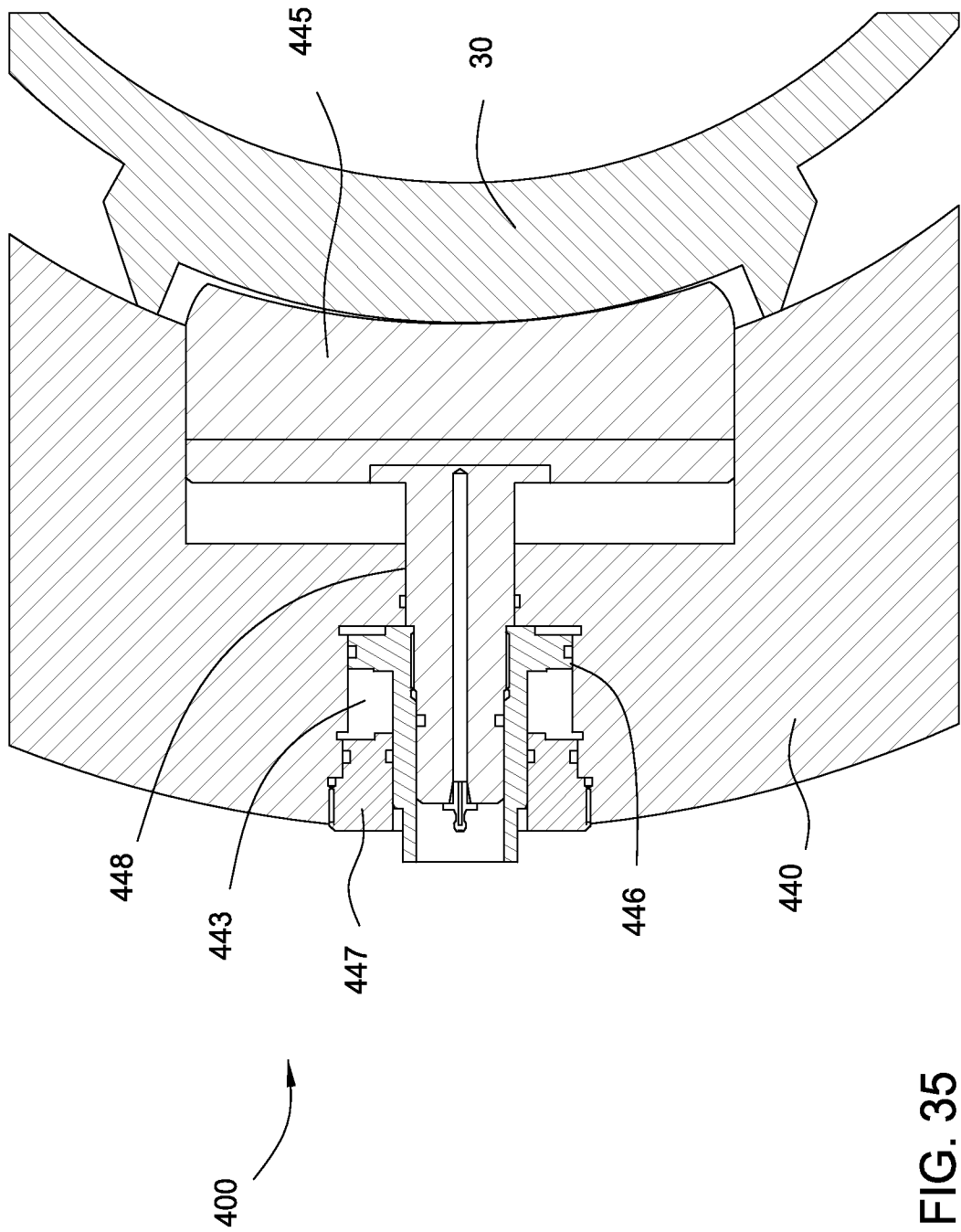

FIG. 35



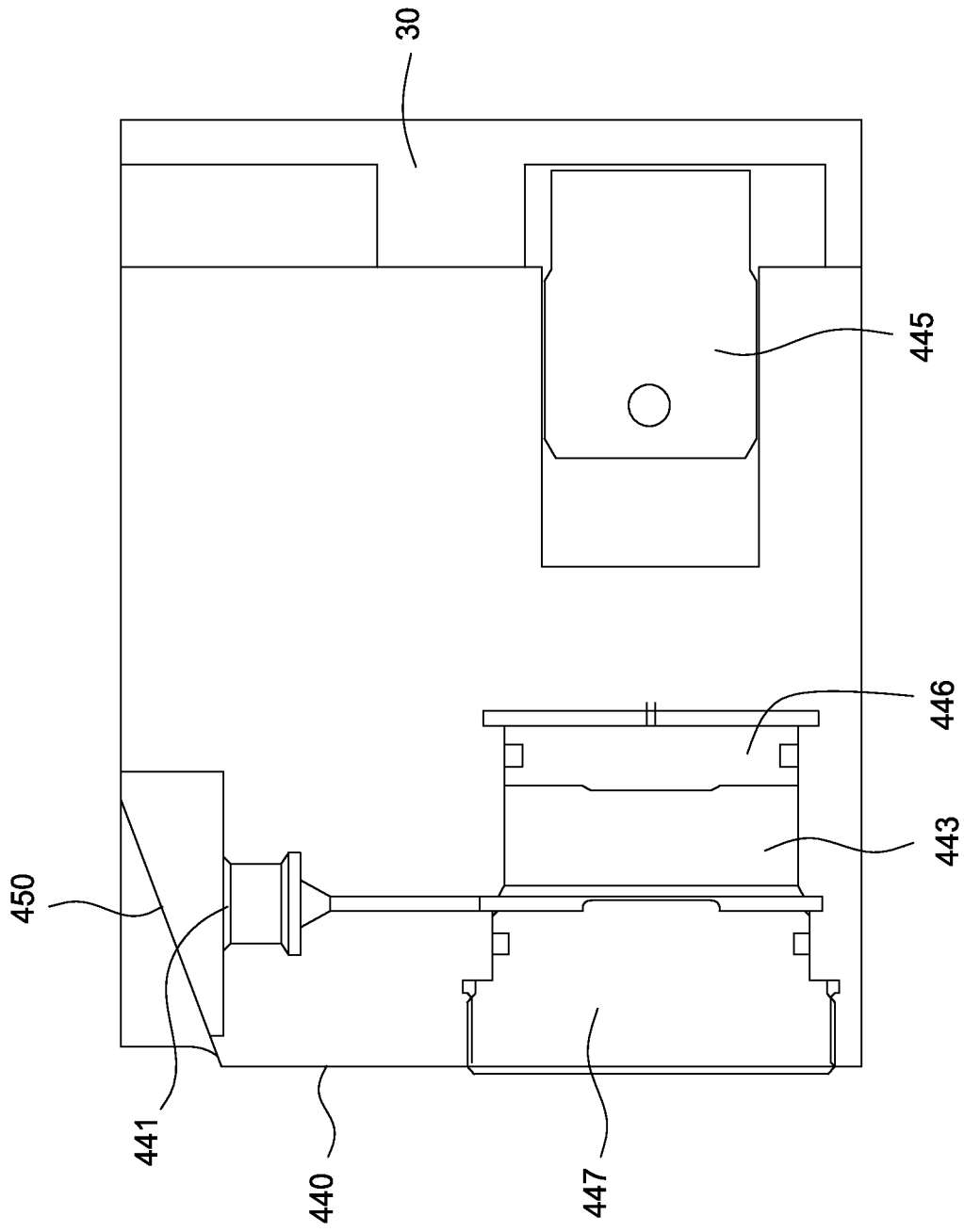

FIG. 36



32/47

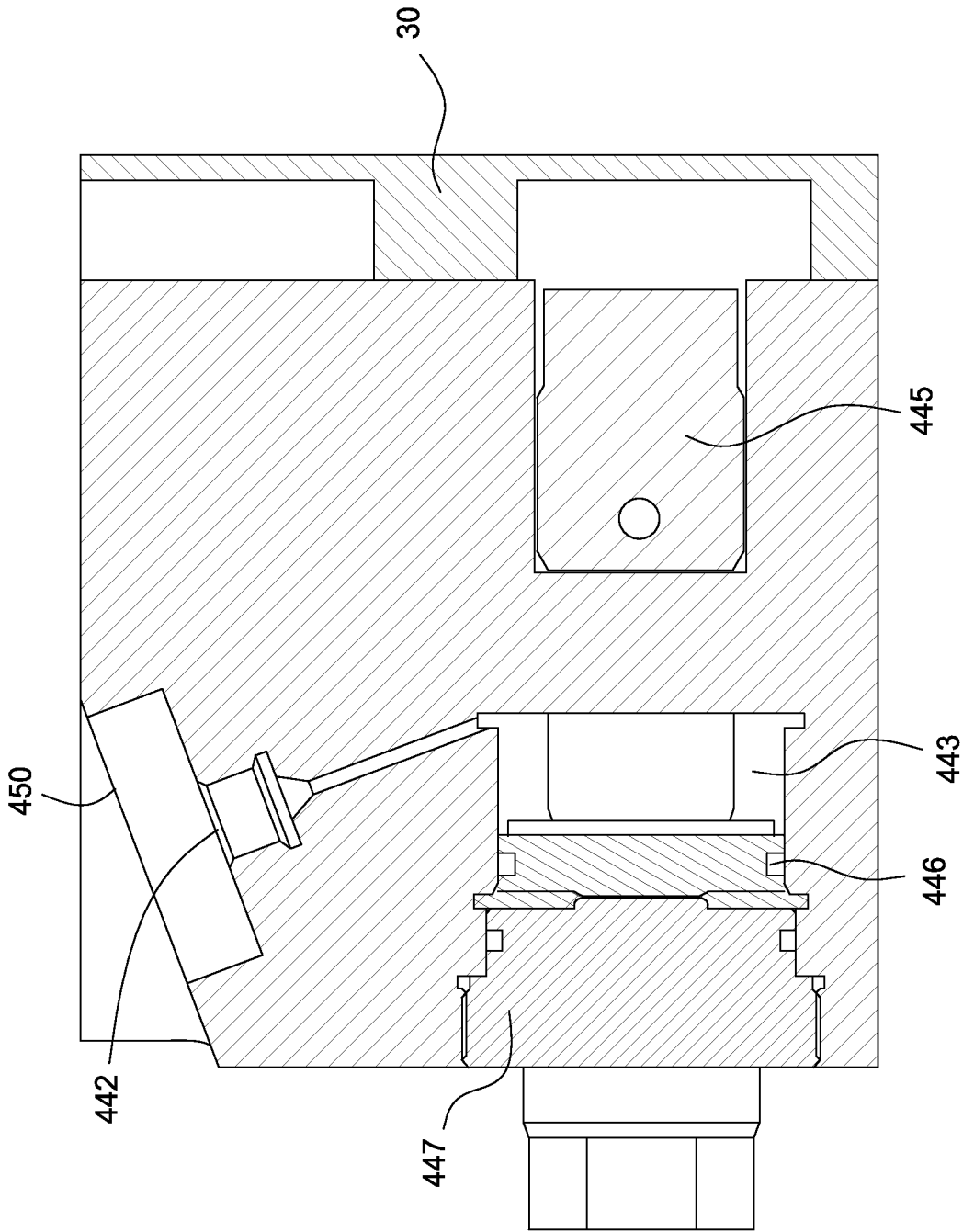

FIG. 37

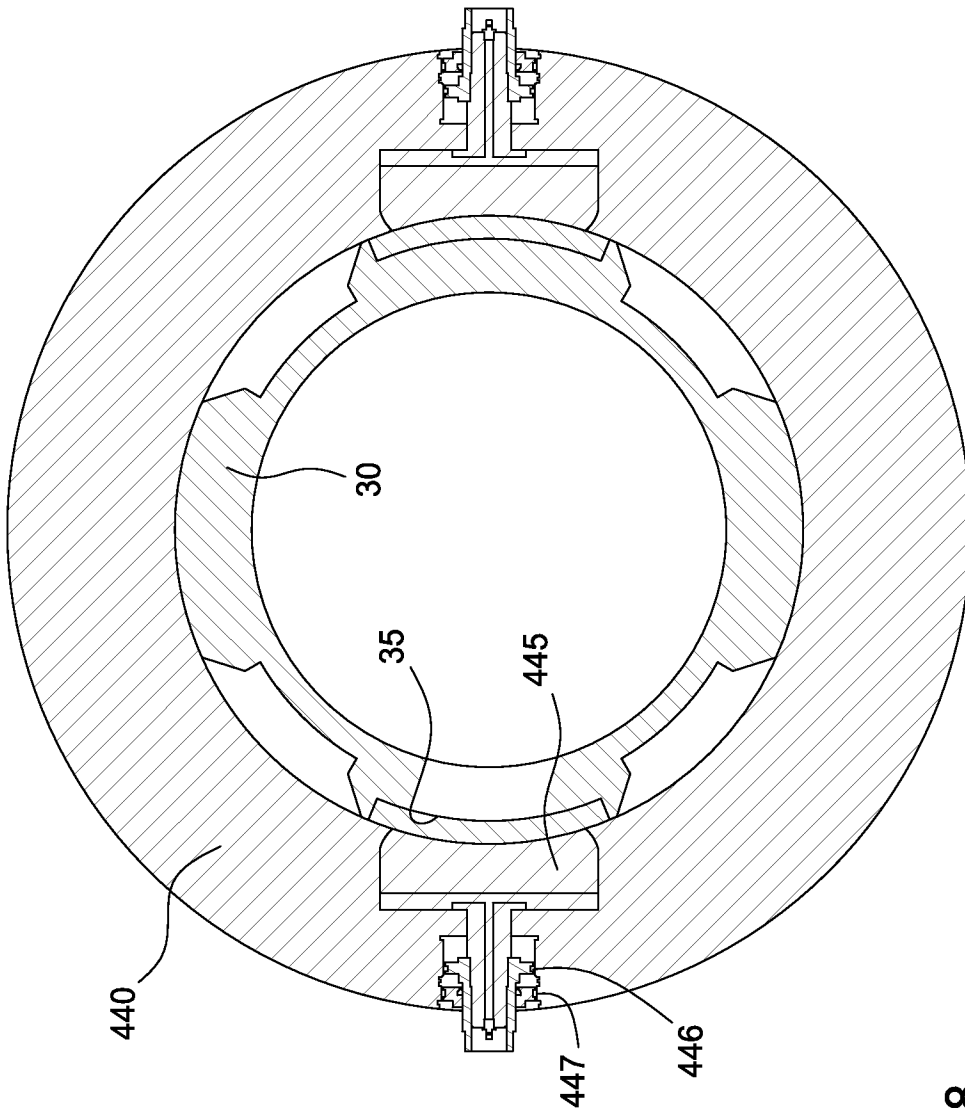

FIG. 38



┌

34/47

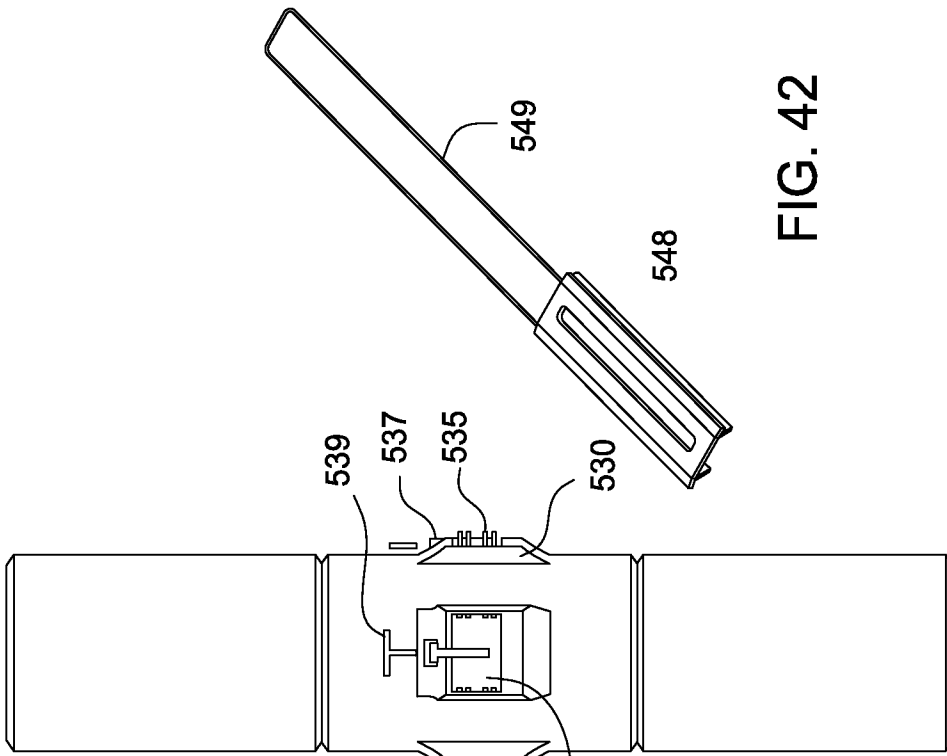

FIG. 42

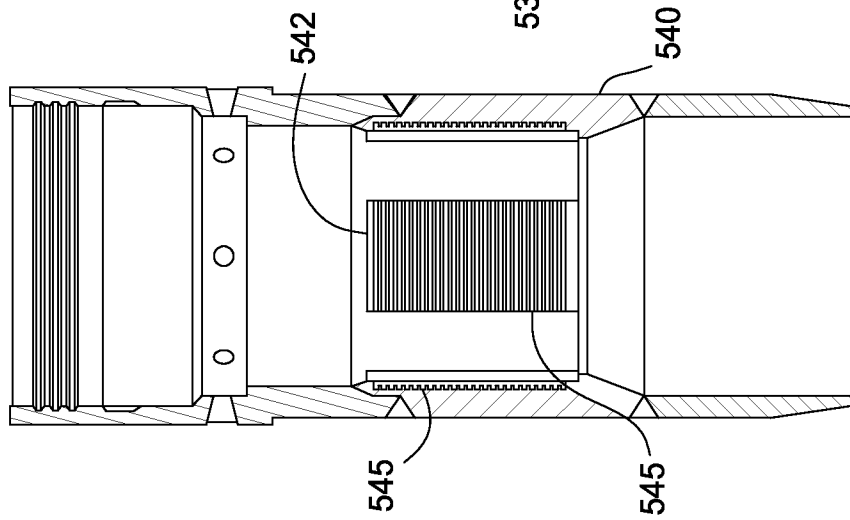
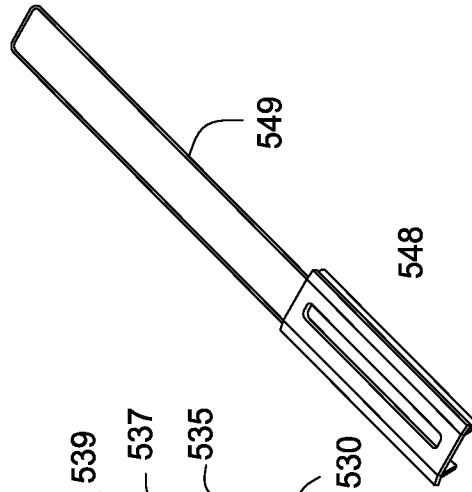

FIG. 41

FIG. 40

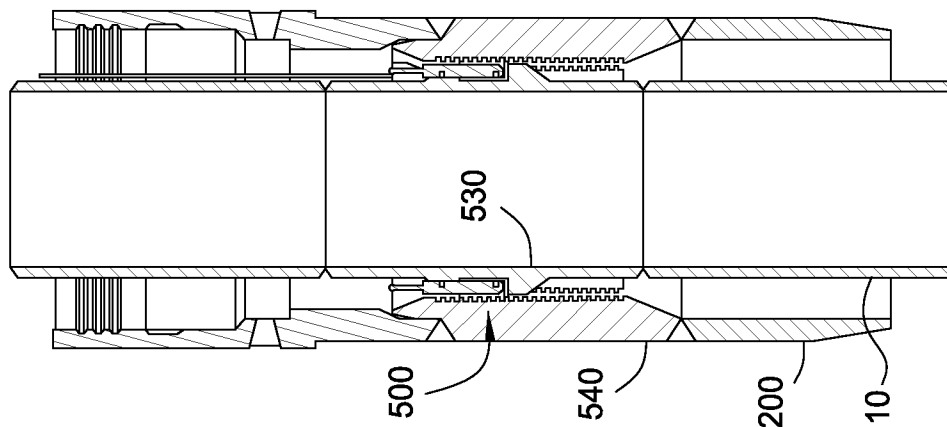

FIG. 39

└

┌

35/47

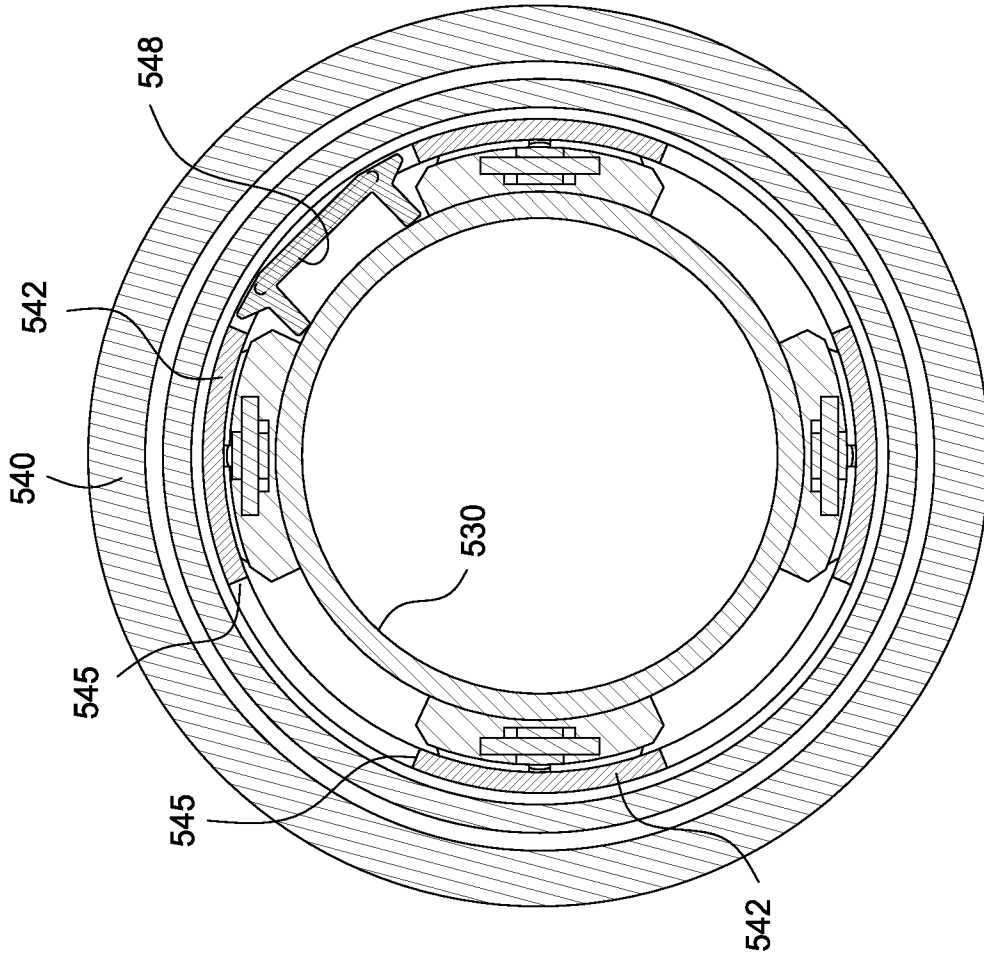

FIG. 44

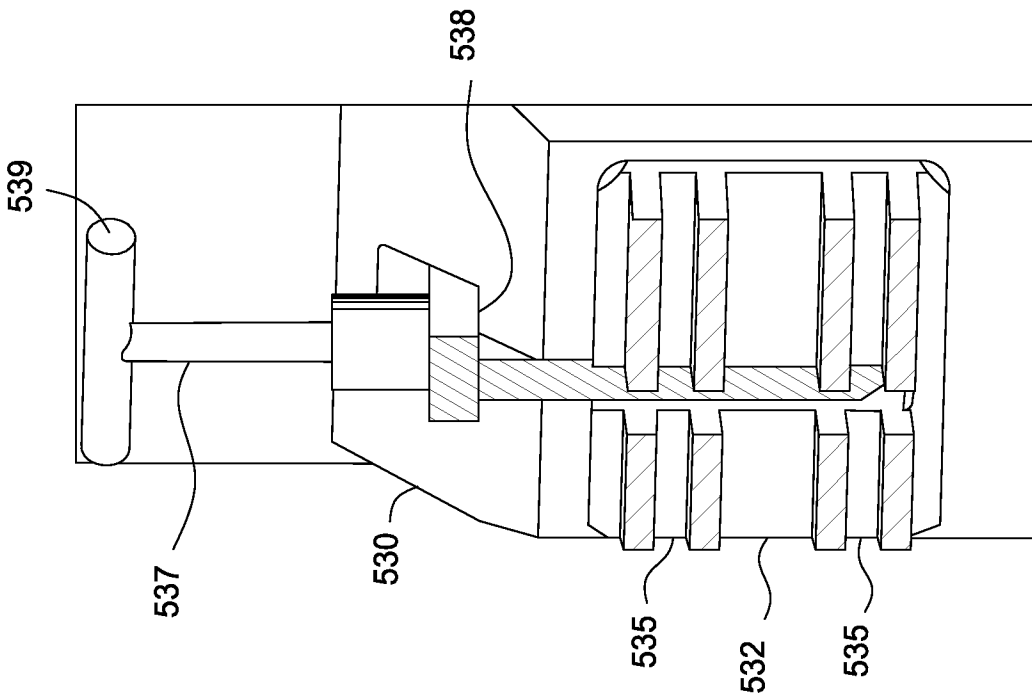

FIG. 43

└

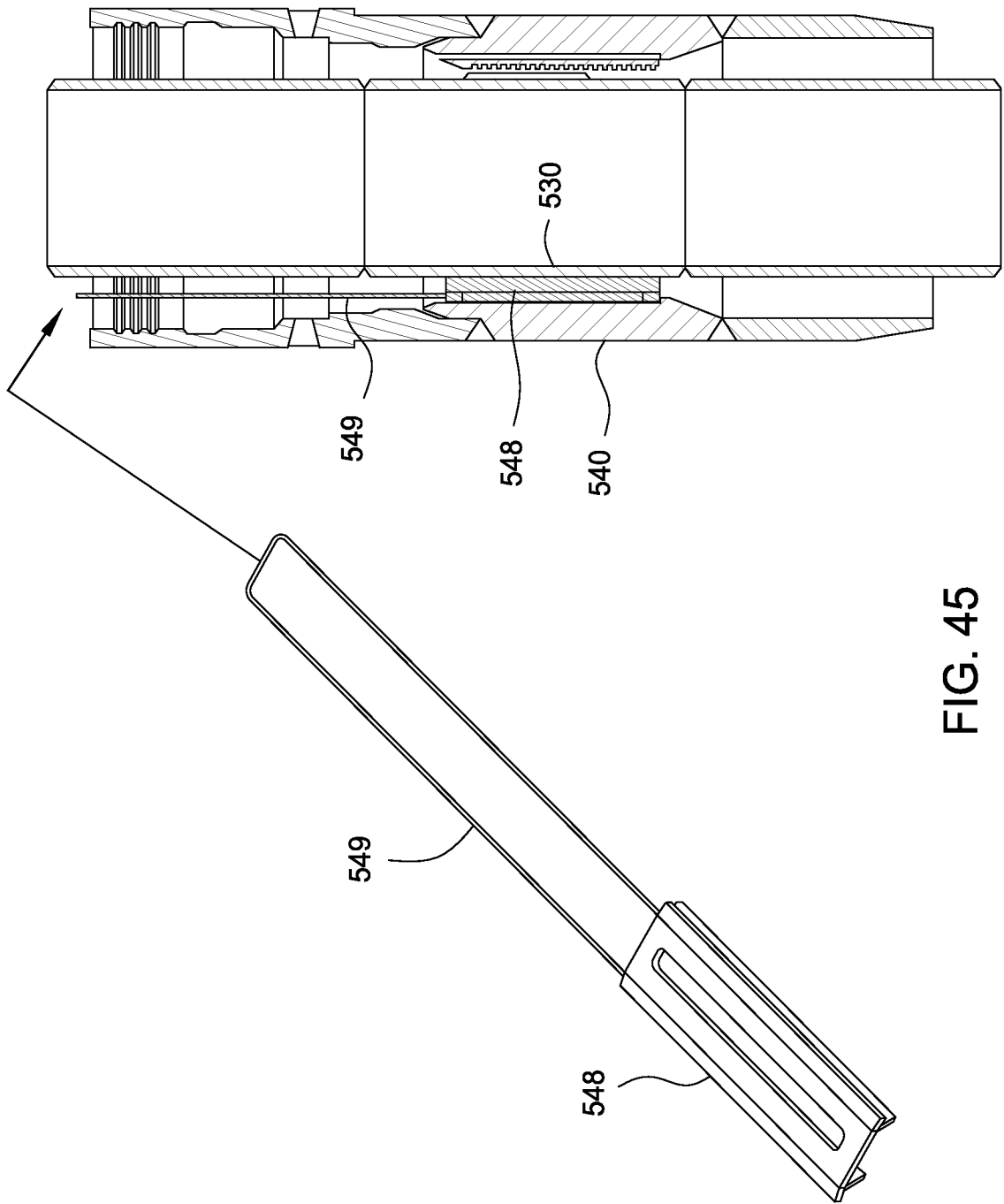

FIG. 45



37/47

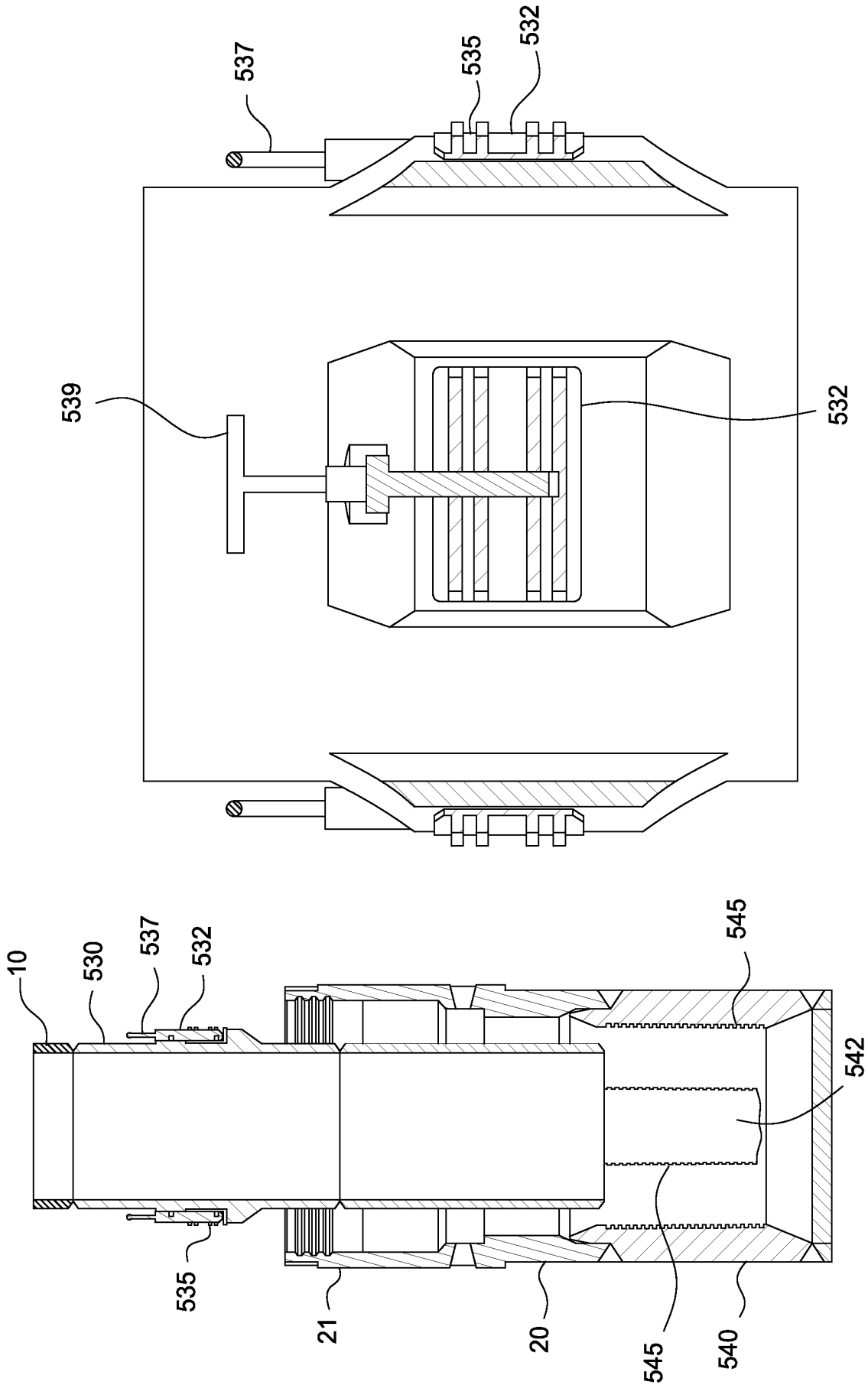

FIG. 46A

FIG. 46

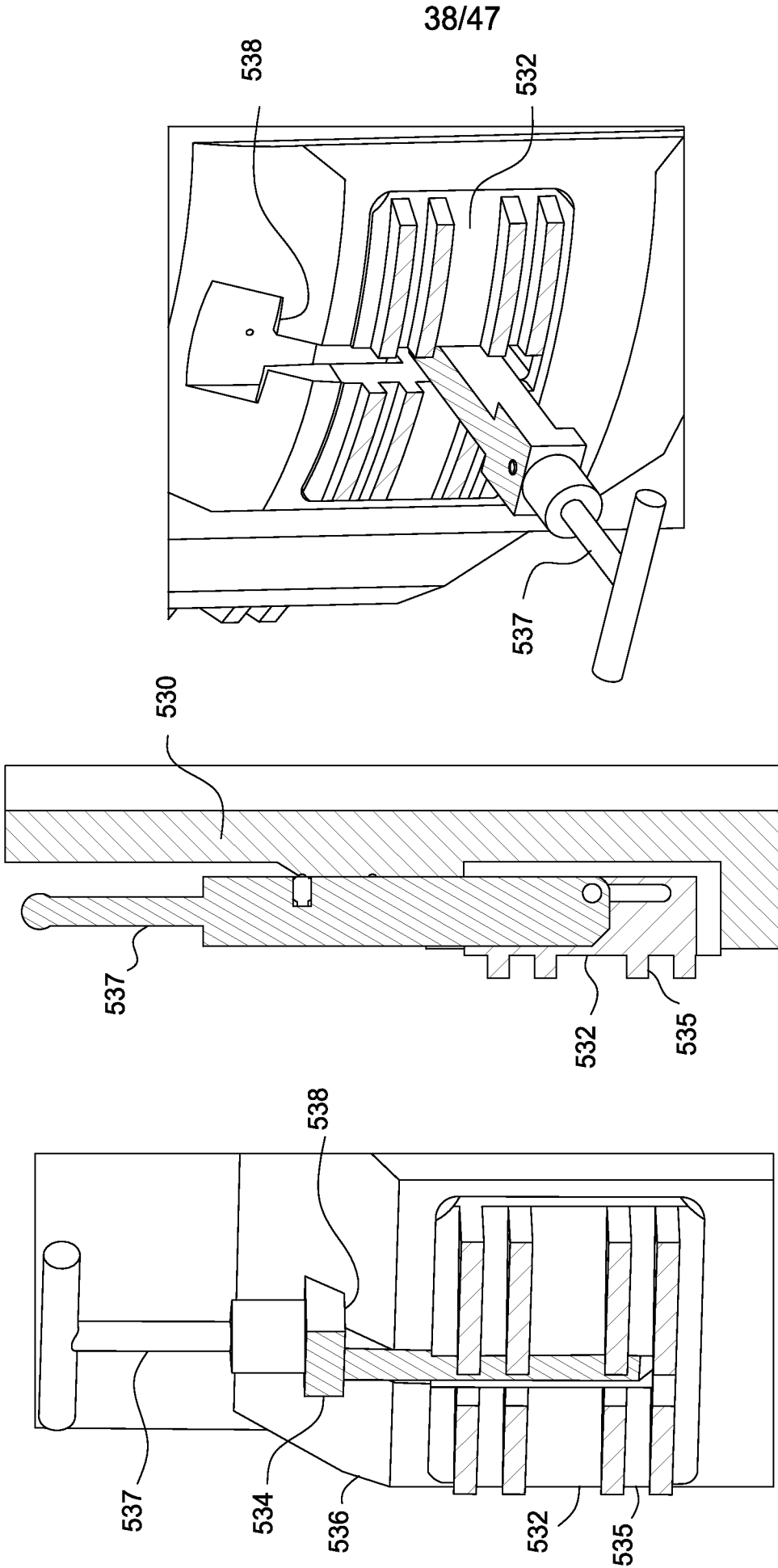

FIG. 47B

FIG. 47A

FIG. 47





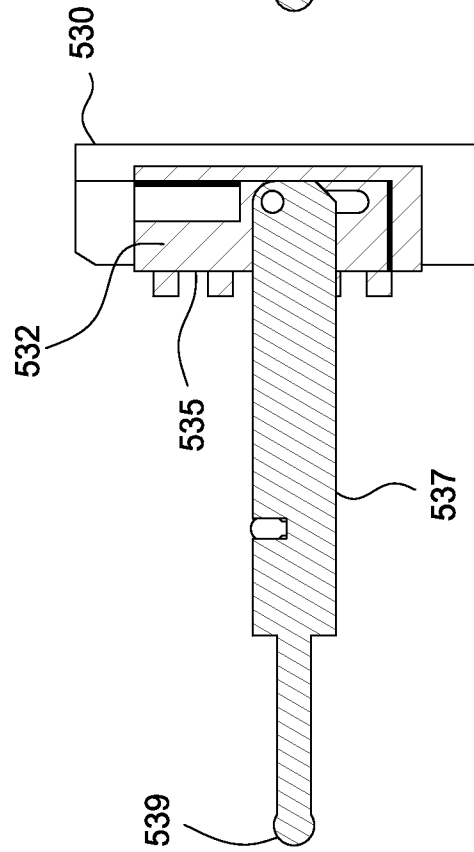
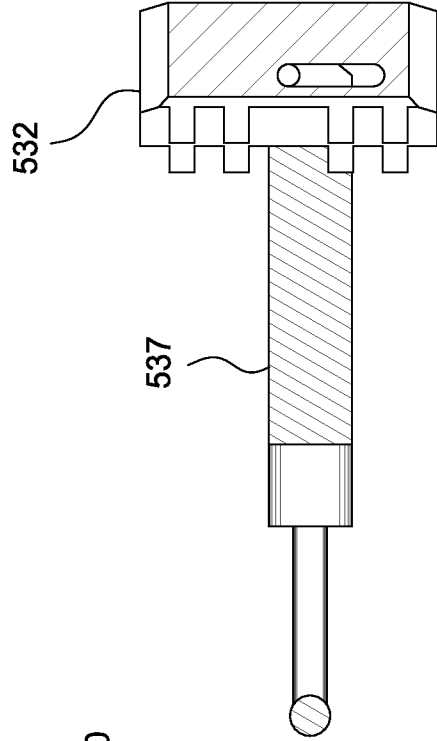
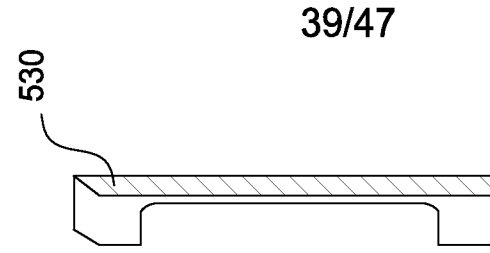

FIG. 49

FIG. 48



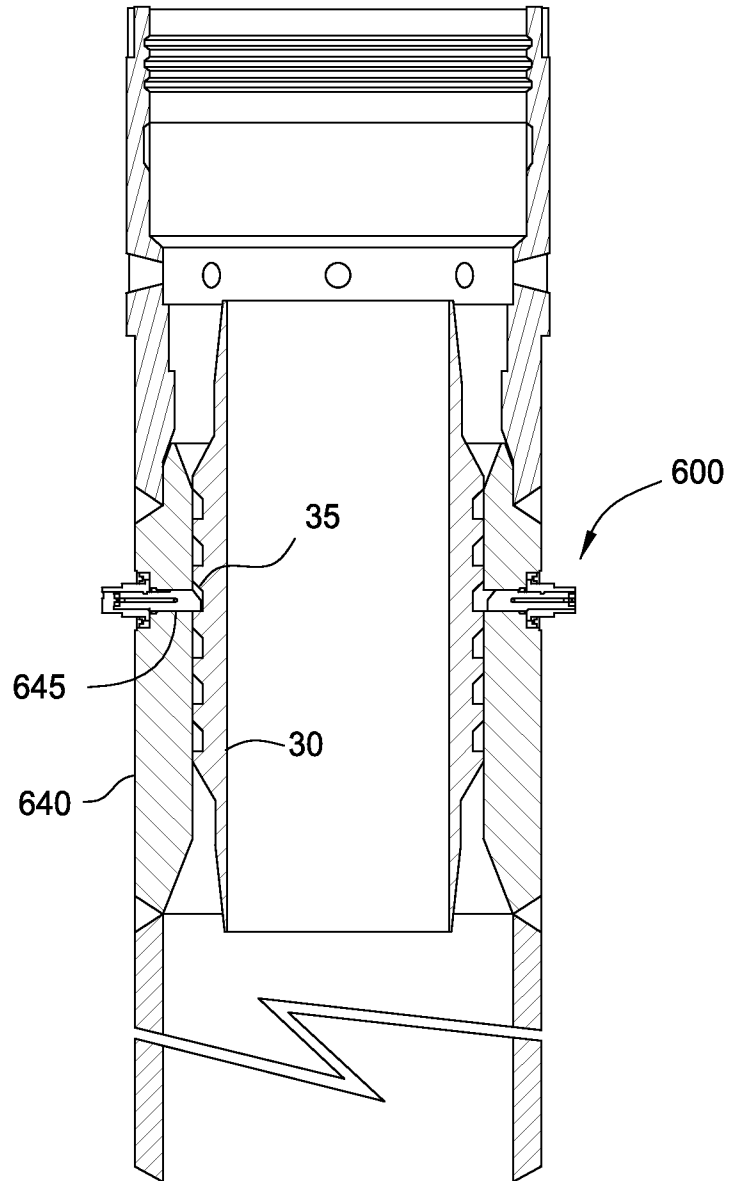

FIG. 50

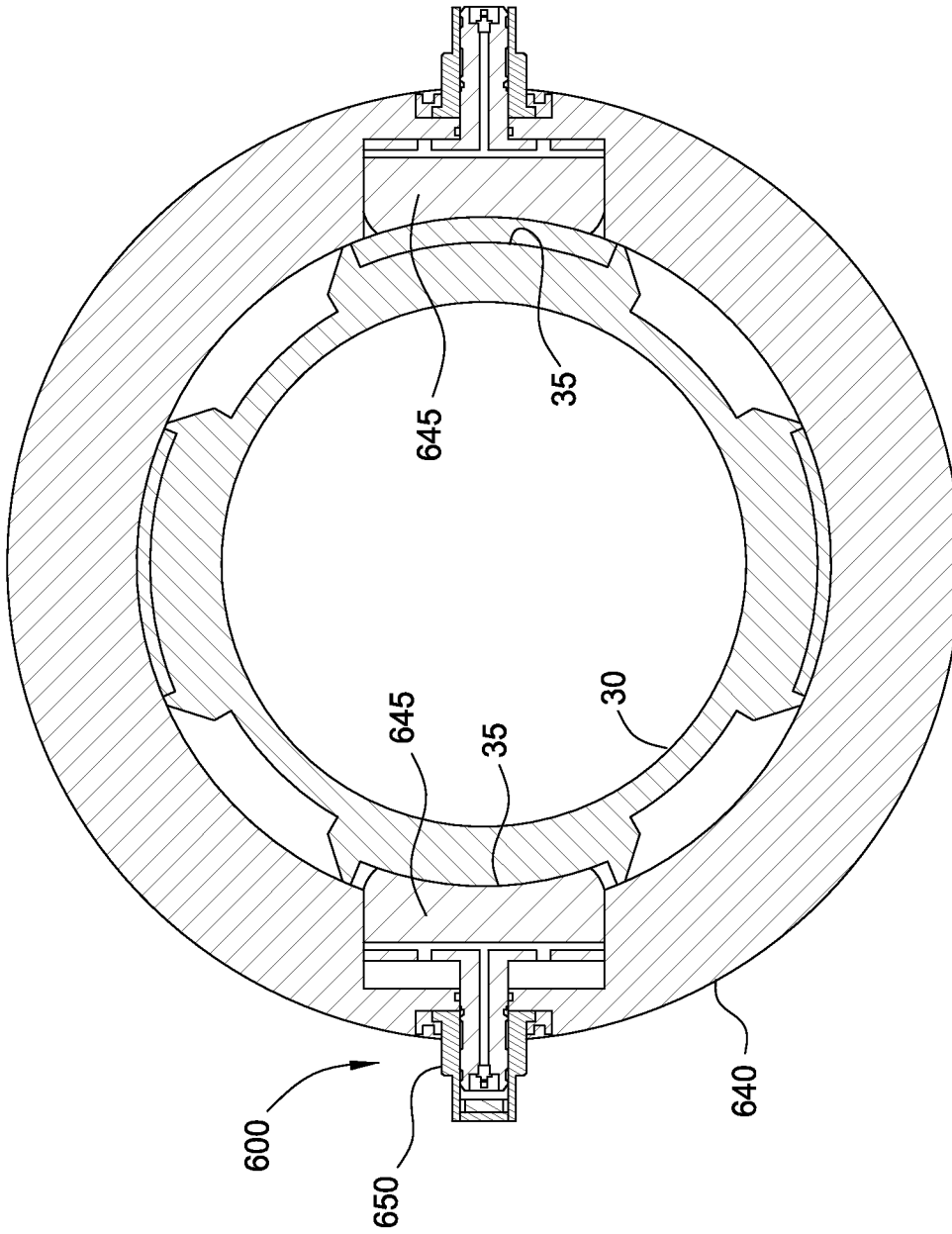

FIG. 51



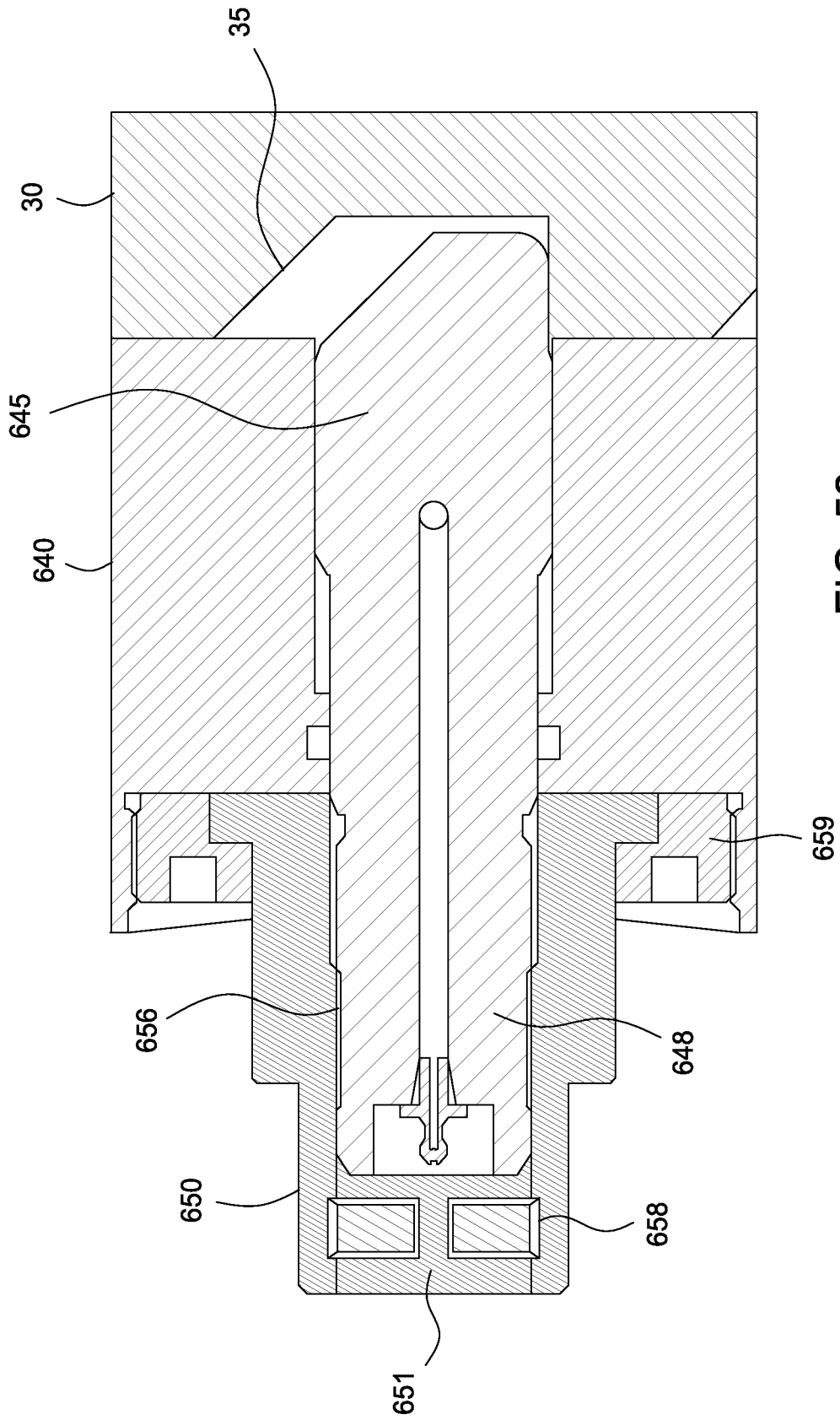

FIG. 52

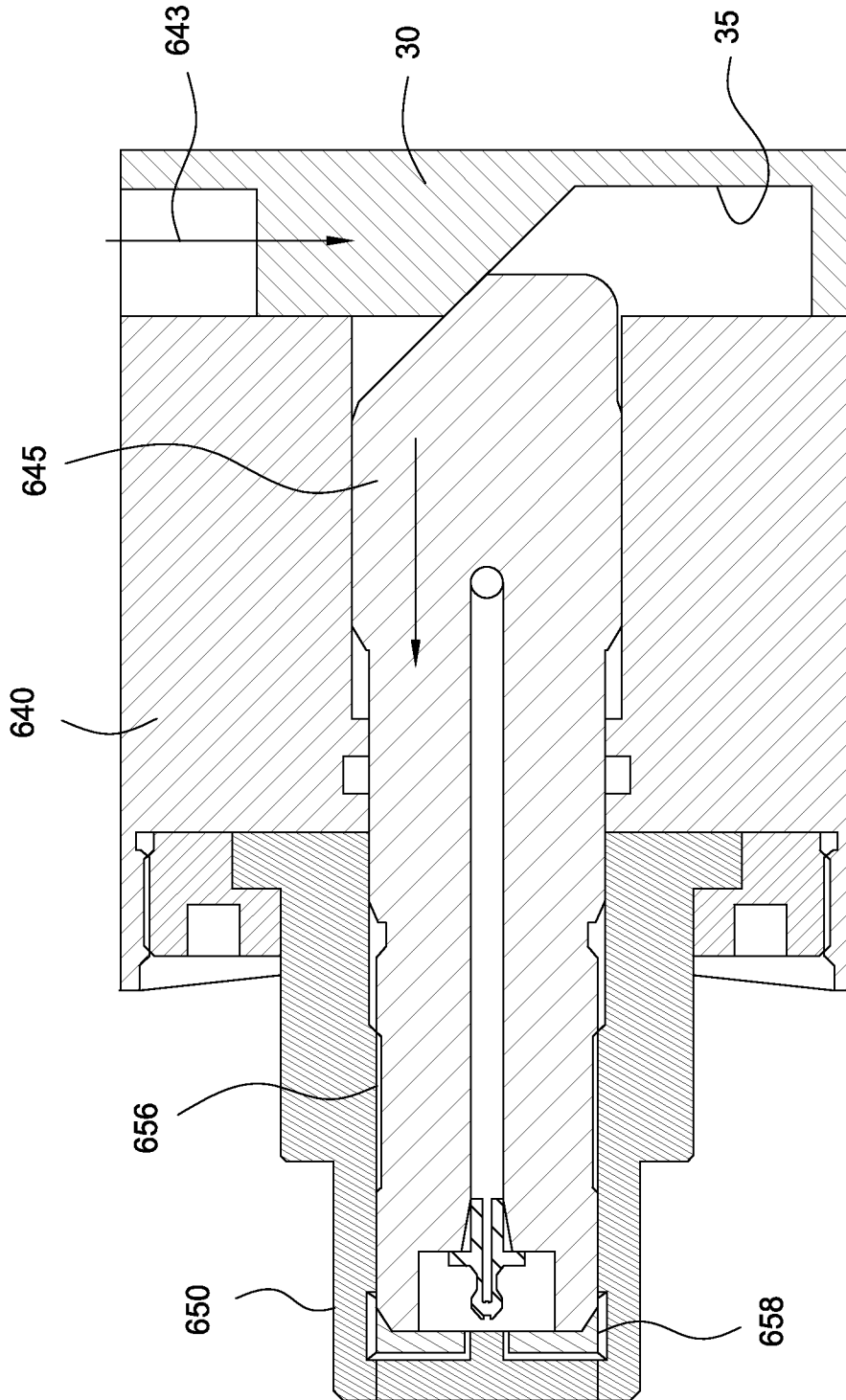

FIG. 53

44/47

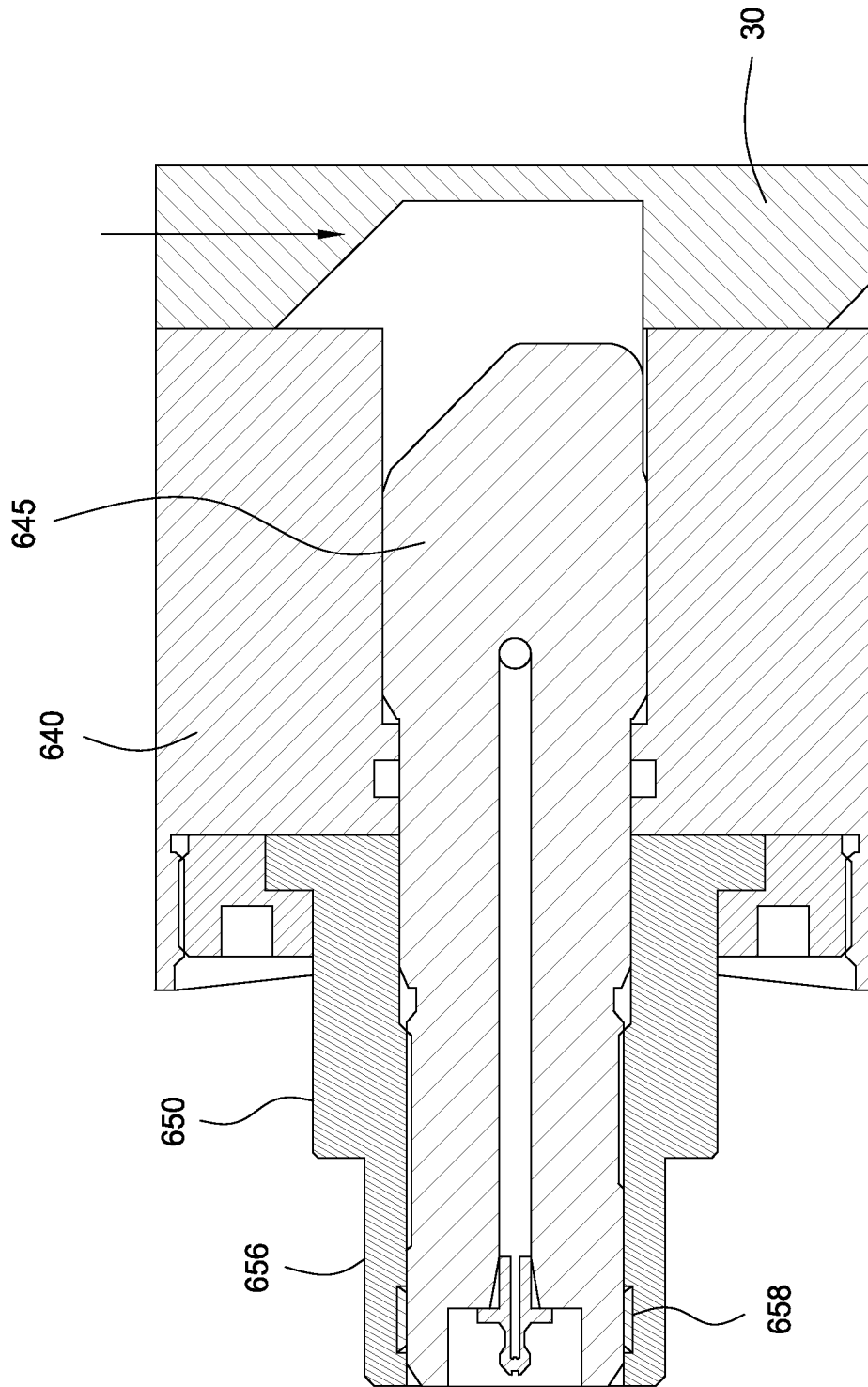

FIG. 54

┌

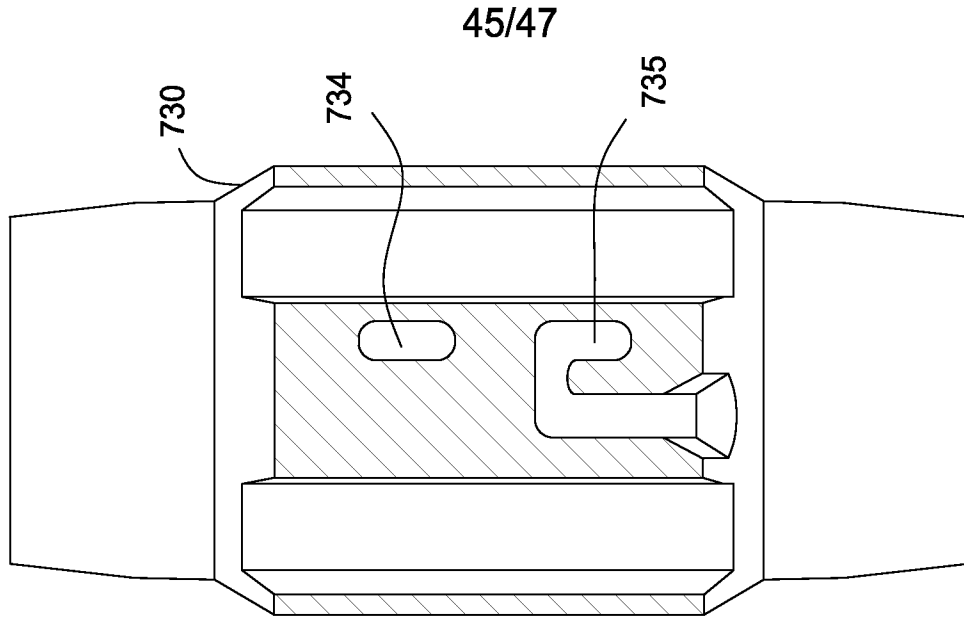

FIG. 55C

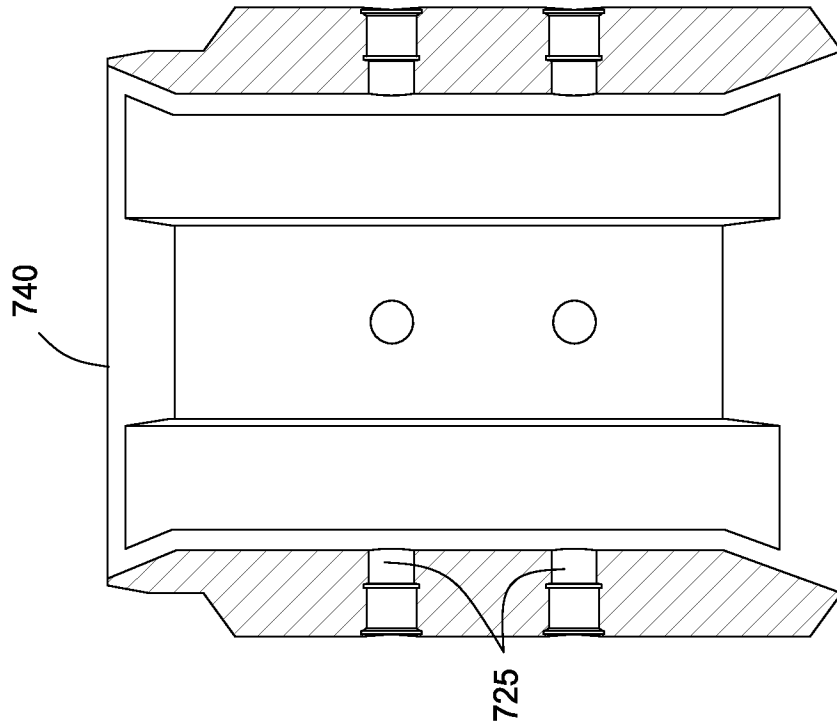

FIG. 55B

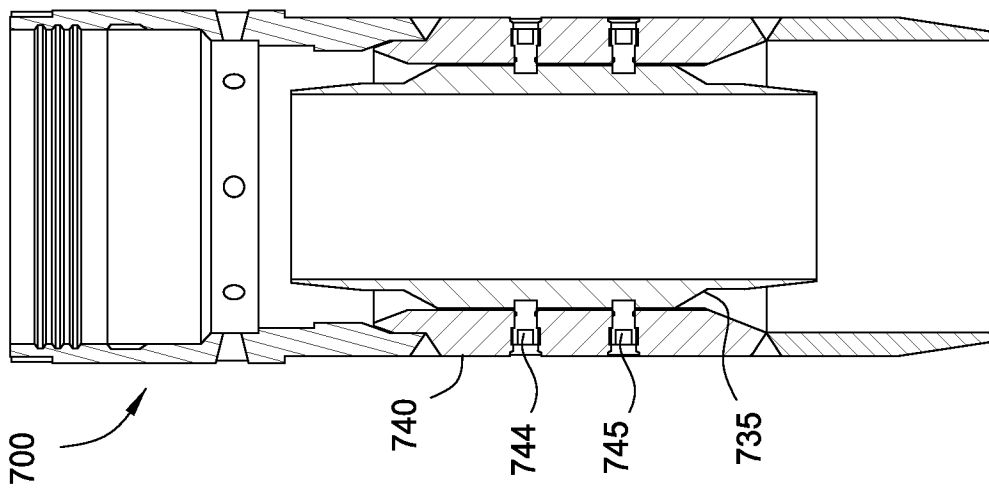

FIG. 55A

└

┌

46/47

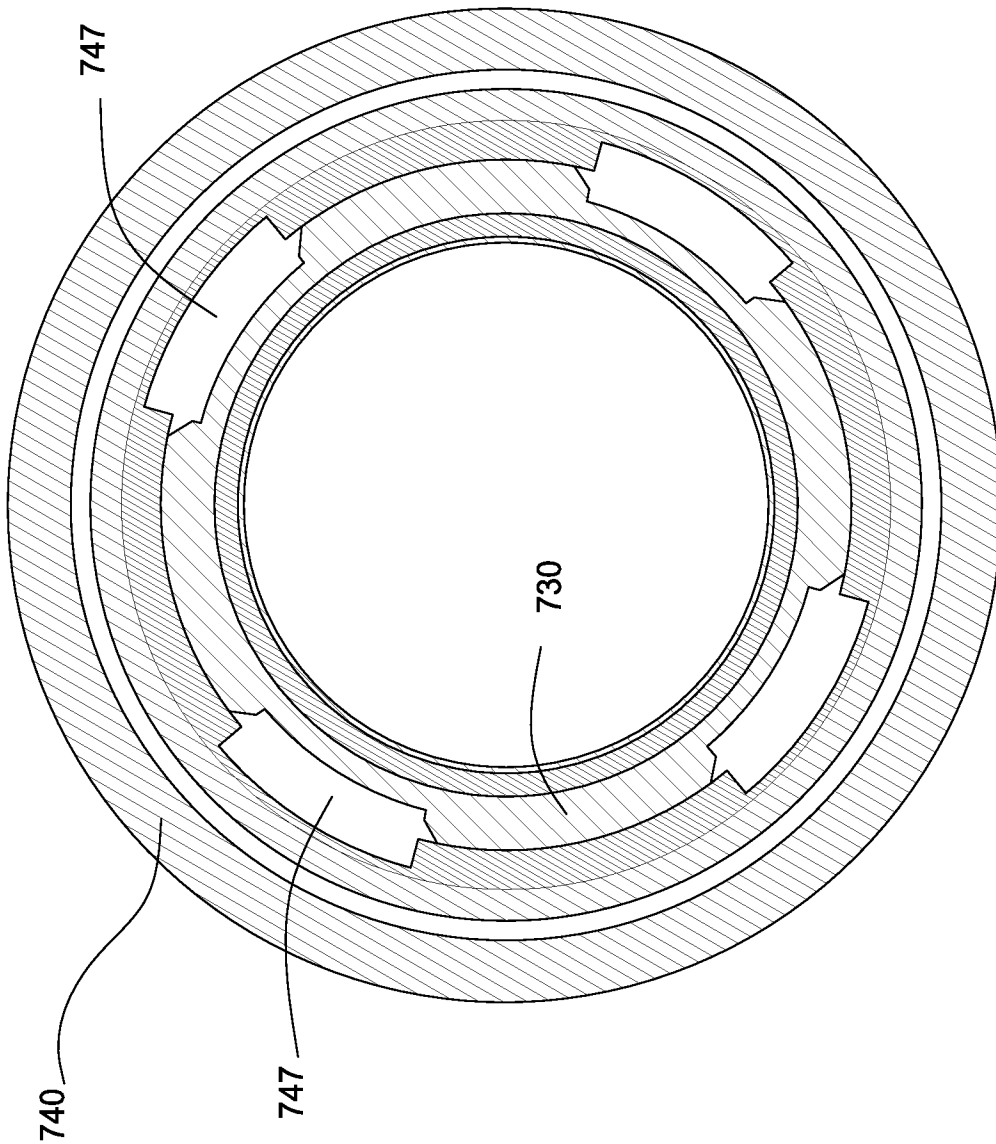

FIG. 56

└



47/47

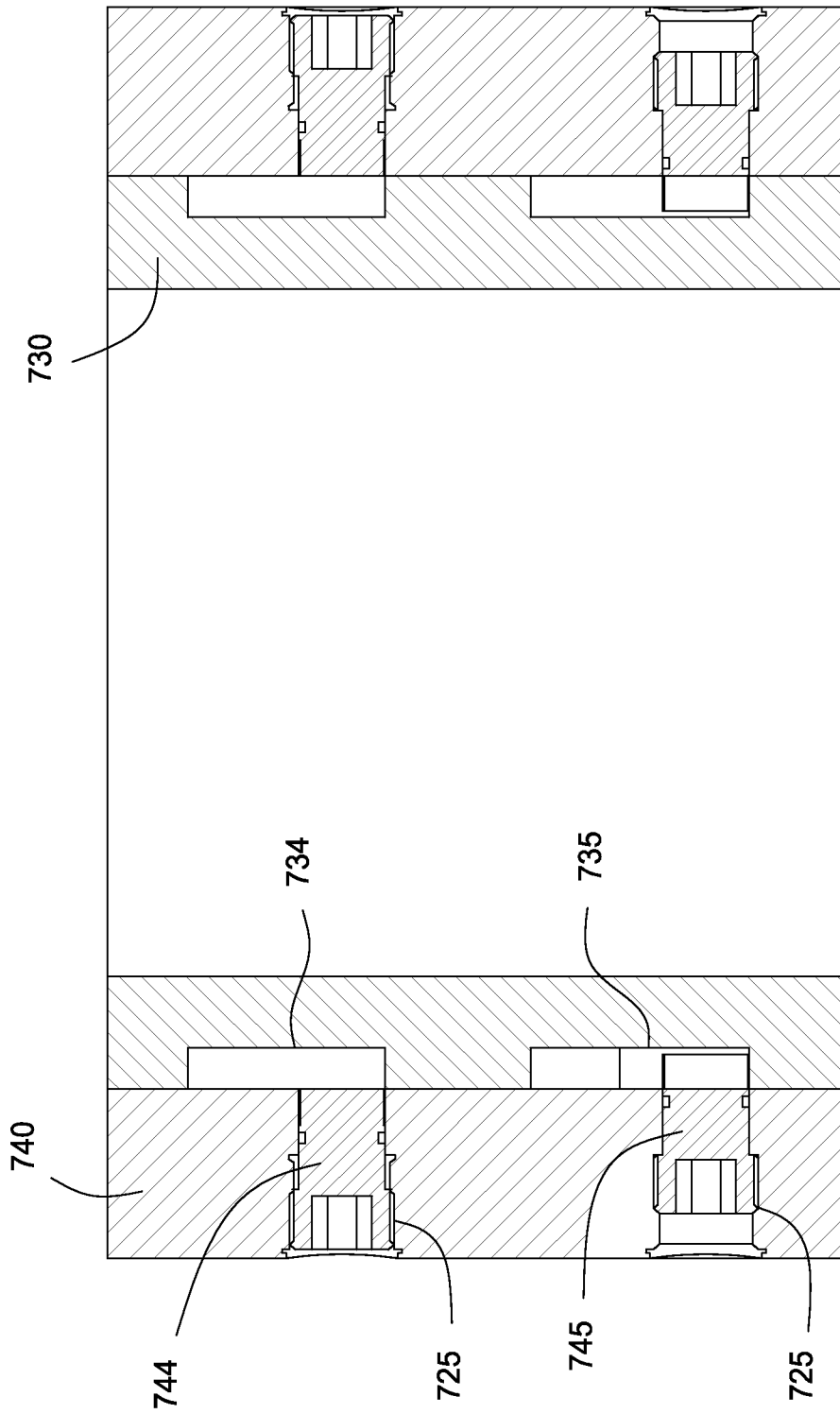

FIG. 57