

No. 635,764.

Patented Oct. 31, 1899.

J. M. GERMANSON.  
REVOLVING CHAIR.

(Application filed June 12, 1899.)

(No Model.)

Fig. 1.

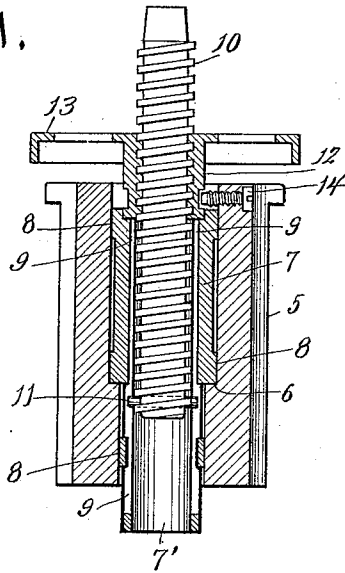

Fig. 2.

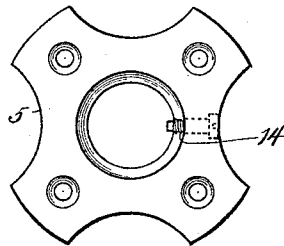

Fig. 3.

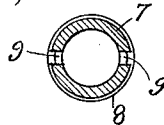
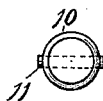

Fig. 4.



Witnesses.

*C. H. Kenney.*  
*Anna V. Faust.*

Inventor.

*Julius M. Germanson*  
*By Remick & Morsell*  
*Attorneys.*

# UNITED STATES PATENT OFFICE.

JULIUS M. GERMANSON, OF MILWAUKEE, WISCONSIN, ASSIGNOR TO THE WESTERN MALLEABLE AND GREY IRON MANUFACTURING COMPANY, OF SAME PLACE.

## REVOLVING CHAIR.

SPECIFICATION forming part of Letters Patent No. 635,764, dated October 31, 1899.

Application filed June 12, 1899. Serial No. 720,184. (No model.)

*To all whom it may concern:*

Be it known that I, JULIUS M. GERMANSON, of Milwaukee, in the county of Milwaukee and State of Wisconsin, have invented a new and useful improvement in Revolving Chairs, of which the following is a description, reference being had to the accompanying drawings, which are a part of this specification.

The object of my invention is to provide improved means for adjusting the seat of a chair up and down in connection with improved means for adapting the chair-seat to rotate freely while adequately supported. Revolving chairs are made and sold in large numbers. Any new mode of construction that lessens the cost of production is of great value if the new form of construction is as strong and enduring and as reliable in its support and as easily operated as old forms, and if the new form that can be made at a less expense than the old form has also features of excellence relating to steadiness of parts, absence of friction and wear, &c., over the old form, then additional value exists therein. My improved construction contains all these points of superiority over old forms of construction.

The invention consists of the device, its parts and combinations of parts, as herein described and claimed, or the equivalents thereof.

Figure 1 shows my improved chair iron or device in cross-section about centrally. Fig. 2 is a top plan view of the hub. Fig. 3 is a transverse section of the lower portion of the sleeve. Fig. 4 is a view of the lower end of the screw.

In the drawings, 5 is a chair-hub, preferably made of cast metal and adapted to receive therein the upper ends of the legs of the chair, and thereby hold the legs in position, the hub being adapted to support the chair-seat thereon. The hub 5 is provided with a central vertical aperture or bore, the upper portion of which is of larger diameter than the lower portion, there being an annular shoulder 6 at the lower end of the enlarged upper portion of the bore. A sleeve 7, fitted in the larger upper portion of the bore of the hub 5, rests rotatably on the shoulder 6, the sleeve below the shoulder 6 having a less exterior

diameter than the part above that shoulder. The construction of the sleeve is such that the portion above the shoulder 6 is considerably thicker laterally than the part 7' below the shoulder 6, the aperture through the sleeve being substantially of the same diameter throughout the length of the sleeve. For providing bearing-surfaces on the sleeve 7 adapted to bear against the inner surface of the bore of the hub 5 at localities near the top and the bottom of the hub and medially thereof I provide the smooth annular and somewhat-raised surfaces 8 8, which, being adapted to bear laterally against the hub at different planes in the length thereof vertically, adapts the sleeve to be supported thereby in the hub against lateral displacement, while at the same time having only such limited bearing-surface in contact with the interior of the hub as to reduce the friction to the minimum amount. This sleeve is preferably made inexpensively of cast-iron and is provided with a longitudinal groove or grooves 9 9 on its inner surface throughout its length, which groove or grooves in that portion of the sleeve that is thin and projects downwardly below the shoulder 6 may cut through the wall of the sleeve, though it is not necessary that it should do so. The sleeve 7 extends from below the hub to near the top of the hub. A screw 10, which is adapted to support a chair-seat fixed thereon, fits loosely in the chamber of the sleeve and is provided with a pin 11, that projects laterally therefrom at one or both sides and is adapted to enter loosely the groove or grooves 9 and prevent the rotation of the screw in the sleeve, while permitting of the movement of the screw vertically therein. The screw is made of hard metal, preferably of malleable iron or steel; but the pin 11 is readily inserted therein by first drilling a small but suitable hole therefor through the pin transversely. A nut 12, provided with a hand-wheel 13, turns by its thread on the screw 10, and the nut at its lower extremity rests on the sleeve 7, preferably in an annular recess therefor at the top of the sleeve about the bore thereof. The nut 12 is of less diameter than the bore of the upper part of the hub 5, and the nut there-

fore does not in any place bear against the hub 5, either frictionally or otherwise. Near its lower extremity and just above the sleeve 7 the hub 12 is provided with an annular groove exteriorly, and a retaining-screw 14, turning through the hub 5, enters the groove in the nut 12 sufficiently to prevent the removal of the nut from its position in the hub when the retaining-screw is in place. The screw 10, with its pin 11, can when the parts are being put together be readily inserted in the sleeve 7 without any special or peculiar construction of the lower extremity of the screw, since the screw readily enters the chamber of the sleeve and the pin 11 will readily enter the groove or grooves 9 when brought to position to register therewith.

It will be seen that this construction in which the screw is adapted to rotate with the sleeve obviates the necessity of cutting a longitudinal groove in the screw, as has heretofore in some instances been done, which groove-cutting is very expensive, especially as for cutting the groove in large numbers of screws a machine is required specially adapted for such purpose. Also it will be seen that the groove in the sleeve 7, which can be produced in molding and casting the sleeve, is an inexpensive process, and also that the boring the screw transversely for the pin 11 and the inserting the pin in the screw is a simple and inexpensive process, and that as a result of this construction, among other benefits, the screw is adapted to be readily inserted in the sleeve without requiring a special preparation or formation of the lower extremity of the screw, as has been employed in some chair-irons of this general character heretofore.

It will be understood that, in this construction, by rotating the nut 12 by means of the hand-wheel 13 the screw 10 and the seat thereon are readily raised or lowered and that being thus adjusted to a suitable height the chair-seat, with the screw 10 and with the sleeve 7, is free to revolve in the hub 5, there being therefor smooth annular bearings at different planes in the hub 5, but so distributed that bearings occur near the top and near the bottom of the hub, thus preventing undue strain on inadequate parts or lateral displacement.

What I claim as my invention is—

1. The combination with a chair-hub having a smooth vertical bore and a medially-disposed annular shoulder therein, of a sleeve substantially as long as and fitted and revol-

uble in said hub on said annular shoulder therein, a screw fitted loosely in the sleeve and held to rotation therewith while movable endwise therein, and a nut turning on said screw and supported revolubly on said sleeve, the screw being entirely inclosed by the sleeve and the nut from end to end of the hub and so that the screw cannot contact with or wear against the hub.

2. The combination with a chair-hub having a smooth vertical bore and a medially-disposed annular shoulder therein, of a sleeve substantially as long as and fitted and revoluble in said hub on said annular shoulder therein, exterior annular bearing-surfaces on the sleeve adapted to bear against the hub near the top and the bottom of the hub and above and below the annular shoulder on the sleeve whereby it is supported in the hub, a screw fitted loosely in the sleeve and held to rotation therewith, and a nut on the screw supported on the sleeve.

3. The combination with a chair-hub having a smooth vertical bore and a medially-disposed annular shoulder therein, of a sleeve fitted loosely in said hub and supported revolubly on said annular shoulder therein, said sleeve being provided longitudinally thereof with a groove or grooves in its inner surface, a screw fitted loosely in said sleeve and provided with a laterally-projecting pin or pins entering said groove or grooves and holding the sleeve to rotation with the screw, and a nut turning on the screw and supported on the sleeve.

4. The combination with a chair-hub having a smooth vertical bore and a medially-disposed annular shoulder therein, of a sleeve substantially as long as and fitted and revoluble in the hub on said annular shoulder therein, a screw fitted loosely in and revoluble with the sleeve but movable endwise therein, a nut turning on the screw and supported revolubly on the sleeve within and at a distance from and constantly out of contact with the wall of the bore of the hub, and a holding-screw turning through the hub above the top of the sleeve and into an annular groove in said nut.

In testimony whereof I affix my signature in presence of two witnesses.

JULIUS M. GERMANSON.

Witnesses:

A. L. MORSELL,  
ANNA V. FAUST.