

PATENT SPECIFICATION

(11)

1 594 776

1 594 776

- (21) Application No. 24504/78 (22) Filed 30 May 1978
(31) Convention Application No. 7 727 955 (32) Filed 8 Sept. 1977 in
(33) France (FR)
(44) Complete Specification published 5 Aug. 1981
(51) INT. CL.³ A01D 82/00
(52) Index at acceptance
A1F 230 232 GB HA

(19)



(54) A FODDER MOWER-CONDITIONER

(71) We, SAMIBEM S.A., of Zone Industrielle, Marmoutier, Bas-Rhin, France, a French Company, do hereby declare the invention, for which we pray that a patent may be granted to us, and the method by which it is to be performed, to be particularly described in and by the following statement:—

The present invention relates to an improvement in mower-conditioners.

Most of these machines are drawn behind a tractor, or semi-mounted in a rear lateral position in relation to the tractor. These machines are therefore poorly manoeuvrable, bulky and difficult to drive in the working position. Moreover they are difficult to use in the transport position, either by reason of their bulk and weight or by reason of their non-functional adaptation to the tractor.

In order to remedy these drawbacks it has been proposed that a mower-conditioner, in the working position, may be disposed no longer behind a tractor necessary for its operation, but laterally beside the said tractor.

A mower-conditioner thus hitched to a tractor is very manoeuvrable by reason of the fact that, in turning, the momentary centres of rotation of the wheels of the tractor and of the machine are substantially coincident. Thus there is no risk of running over already cut fodder or of crushing the still standing fodder.

Moreover, in order further to increase the compactness and the output of such a mower-conditioner, it is proposed to equip it with a cutting mechanism of working width (L) greater than the conditioning width (D) separating the two walls of the conditioning passage of the machine.

The purpose of the present invention is to simplify the drive, that is to say both the device for coupling in the working position and the device for rotating drive of the cutting mechanism and the conditioning mechanism of a mower-conditioner of the type as described above, without thereby increasing its overall width.

According to the invention, there is

provided a mower-conditioner of the kind which when in use is hitched laterally beside a tractor and comprises a cutting mechanism and a conditioning mechanism, the latter being provided with a lateral wall which bounds a conditioning passage at that side of this passage where this passage is closest to the tractor when in use, characterised in that a double-output control box and a bearing carrier are carried by the said wall, the bearing carrier carries a bearing of a power input pulley drivingly connected by belts to the said control box, a stiffening post is connected to the control box and to the bearing carrier for the purpose of resisting deformation of the said wall, when the belts are taut, and there is also a tube which is connected to the said wall and forms part of a hitching arrangement by which the mower-conditioner, when in use, is hitched to the tractor in a manner permitting the mower-conditioner to oscillate about an axis extending substantially in the direction in which the mower-conditioner travels when in use.

The advantage of such a construction resides in the fact that the afore-mentioned post avoids deformation of the wall of the conditioning passage and permits the bearings of the conditioning rotor to remain correctly aligned, on the one hand when the belts passing over the pulley of the control box and over the input pulley are tensioned, and on the other hand during driving of the machine in the working position in which its change of direction is determined by the modification of the orientation of a male element which is fast with the tractor and engages in the tube constituting the hitch device of the machine.

This male element, the orientation of which is modified when the tractor is turning, exerts a lateral force upon the said tube for the purpose of causing the machine to follow a path parallel with that of the tractor. It is necessary that this tube and the element upon which it is fixed should not be deformed, in order not to disturb the operation of the machine.

100

According to another characteristic of the present invention the post and the tube are situated outside the conditioning passage but on the near side of the trajectory 5 of the cutting elements of the cutting mechanism, in the region where the said trajectory is closest to the tractor.

According to this characteristic, the overall width of the machine is equal to the width (L) of its cutting mechanism, which contributes effectively to the compactness of the machine, to ease of driving in working and to optimum output.

Thus the above-stated characteristics permit of designing a mower-conditioner 15 of solid but light construction which, for a given working width, is substantially less costly than the mower-conditioners existing on the market.

The invention will be explained in greater detail, with further characteristics and advantages, hereinafter by means of a non-limitative example of embodiment described with reference to the accompanying drawings, wherein:—

Figure 1 represents a plan view of a mower-conditioner in the working position,

Figure 2 represents a detail of Figure 1, on a larger scale,

Figure 3 represents a front view of the wall of the mower-conditioner according to Figure 1, this wall being provided with the elements for the drive of the machine.

In the drawings, as represented in Figure 35 1 the agricultural machine hitched in the working position to the tractor 1 is of the mower-conditioner type. This machine comprises a chassis 2 supported by wheels 3 provided on each side of the said chassis 2.

40 The cutting mechanism of the mower-conditioner comprises supports for cutting elements in the form of discs 4 which extend all in one and the same plane, as close to the ground as possible, perpendicularly to the direction F of travel of the mower-conditioner. These discs 4, which are of oval form, are provided with cutting elements such as blades 5. These blades 5, articulated at 6 to the discs 4, place themselves in position radially under the action of centrifugal force on rotation of the discs 4 as indicated by the directions of the arrows *f*, and describe circular trajectories 7. Each of the end discs 4 is surmounted 55 by a frusto-conical element 8 intended especially cleanly to separate the cut fodder from that still standing and to facilitate its conveying towards the rear by means of members such as ribs 9 and horns 10 (Fig. 60 3) fixed on the said element 8. The rotating drive of the discs 4 is effected by means of transmission members (not shown), such as a train of pinions for example, lodged in a sealed oil-bath box 11 extending beneath 65 the discs 4 and articulated at 12 to the

chassis of the machine, being connected to the said chassis 2 by means of brackets 13. The box 11 is held in a fixed position in relation to the chassis 2 by means of screws 14.

70 From Figure 1 it may be noted that the trajectories 7 of the blades 5 of the discs 4 partially overlap. These trajectories 7 are situated one beside the other and aligned perpendicularly of the direction F of travel 75 of the machine and the tractor 1. Thus the forward part of these trajectories 7 determines the cutting front of the machine the width L of which substantially corresponds to the overall width of the machine. 80

The present invention is not limited to the disc-type cutting mechanism as described above. Other types of cutting mechanism can in fact be perfectly suitable for use in the mower-conditioner. 85

The conditioning mechanism of the machine is constituted by a rotor 15 driven in rotation about the horizontal axis of a shaft 16 situated above the discs 4 and slightly behind the line on which the vertical 90 axes of rotation of the said discs 4 are situated.

This rotor 15 is here of the type comprising flails 17. These flails 17 pick up the fodder cut by the blades 5 of the discs 4 95 for the purpose of passing it between the teeth of a fixed comb (not shown). This comb is regulable so that the degree of conditioning of the fodder can be varied.

In fact the control handle 18 of the 100 comb may be seen in Figures 2 and 3. This handle 18 can be set into different positions and be immobilised in these positions by virtue of notches 19 which correspond to the different degrees of conditioning 105 of the fodder which it is possible to obtain with the machine according to the invention.

The present invention is not however, limited to the above stated type of conditioning. The conditioning can be obtained 110 very well with the aid of profiled rubber and/or metal rollers for example.

The rotor 15 with flails 17 as represented in Figure 1 is mounted on a horizontal 115 shaft perpendicular to the direction F of travel of the machine. Each extremity of the shaft of the rotor 15 is guided respectively on the one hand in a bearing (not shown) provided on the left lateral wall 20 120 of the conditioning passage and on the other hand in a bearing 21 provided on the right lateral wall 22 of the conditioning passage.

The bearing 21 is advantageously fixed on the outer face of the wall 22. The conditioning 125 passage in which the rotor 15 is lodged thus comprises a minimum of sharp parts to which fodder debris might attach itself, in passing through the said passage.

Two windrowing plates 23 and 24 are 130

provided at the end of the conditioning passage, which is upwardly closed by a hood 25. The windrowing plates 23 and 24, the positions of which are adjustable by means of a lever 26 (Figure 2), permit control of the size of the windrow which the conditioned fodder will form in being deposited on the ground behind the machine.

The two lateral walls 20 and 22, bordered on the major part of their periphery by an assembly of U-irons 27 welded to the said walls, are situated at a distance l from one another. This distance, which corresponds to the width l of the conditioning passage, is substantially less than the width of the cutting front L . The conditioning passage is centred substantially in the middle of the cutting front of width L . Therefore if the machine is considered in its direction of travel, there exist two free zones situated respectively on each side of the lateral walls 20 and 22. These zones are respectively preceded or forwardly bordered by at least a part of the discs 4 situated at the extremities of the cutting front of the mower-conditioner. These zones are utilised for the installation of the wheels 3 carrying the machine and for the installation of the transmission and coupling members fast with the machine, provided that the said members are situated outside the conditioning passage and on the near side of the trajectory 7 of the cutting elements 5 of the cutting mechanism, in the region where the said trajectory 7 is closest to the tractor 1.

The driving of the end disc 4, surmounted by its frusto-conical element 8 and situated closest to the right rear wheel 28 of the tractor 1, is effected by means of a control box 29 fixed on the outer face of the lateral wall 20 of the conditioning passage. This control box 29 comprises two outputs. One of these is coaxial with the said end disc 4 and drives the latter directly in rotation. The rotation of this end disc 4 causes the rotation of the other discs 4 by means of the transmission members lodged in the box 11. The other output of the control box 29 is coaxial with the shaft 16 of the conditioning rotor 15 and permits of driving the latter in rotation.

The mechanism of the control box 29 is actuated by a set of pulleys over which there pass belts 30 protected by a casing 63 (Figure 1). The pulley 31 of the control box 29 is keyed on a shaft the axis of which is the same as that of the conditioning rotor 15. Thus the said pulley 31 directly drives the conditioning rotor 15. The shaft on which the pulley 31 is keyed co-operates with the mechanism of the control box 29 by means of gear trains with the purpose of actuating the end disc 4 situated closest to the rear wheel 28 of the tractor 1.

The said belts 30 pass over a second

pulley or input pulley 32 (Fig. 2). This latter pulley 32 is mounted on a regulable bearing carrier 33. This bearing carrier can in fact be moved away from or toward the axis of the pulley 31, in order to tension the belts 30.

As the tension of these belts 30 is quite large and the pulleys 31 and 32 are relatively remote from the left lateral wall 20 of the conditioning passage, there is risk of deformation of the latter by reason of the long lever arm constituted by the axis of the pulleys 31 and 32. In fact these latter are relatively remote from the lateral wall 20 of the conditioning passage.

Consequently a stiffening post 34 is provided, connected to the wall 20 of the conditioning passage by means of at least one bracket 35 and extending parallel with the latter. This post 34 is disposed between the control box 29 and the spindle 36 of the bearing carrier 33. The bearing of the input pulley 32 is thus articulated to one of the ends of the post 34, while its other end is connected rigidly to the double-output control box 29 by means of a screw 37 and an L-shaped bracket 38 (Figure 2). In one of the arms of this bracket there is provided a bore 39 fitted on the bearing of the pulley 31.

By virtue of the post 34 it is possible to adjust the position of the screw 40 of the regulating device 41 fast with the post 34, to tension the belts 30, without deforming the left lateral wall 20 of the machine. Thus the bearings of the conditioning rotor 15 remain perfectly aligned.

The input pulley 32 is driven in rotation by a telescopic shaft 42 possessing Cardan joints at its extremities. One of these joints is mounted on the splined shaft stub 43 of the input pulley 32 in order to communicate thereto its rotating movement from the power take-up 44 of the tractor 1 and through the intermediary of a shaft 45 similar to the shaft 42. A gear box 46 fixed on the hitch device 47 connects the two shafts 42 and 45.

This hitch device 47 permits the tractor 1 to shift the machine in the working position into a position such that the cutting front L of its discs 4 extends substantially perpendicularly to the plane of the right rear wheel 28 of the tractor 1 and substantially at the level of the said wheel.

The said hitch device 47 connecting the machine to the tractor 1 is fixed to the three-point hitch device 48 of the tractor 1. The hitch device 47 is in the form of an L the larger arm 49 of which is disposed perpendicularly to the direction F of travel of the machine. This arm 49 extends beyond the right rear wheel 28 of the tractor 1. The second arm of the hitch device 47 forms an angle substantially equal to 90°

with the arm 49 and extends forward in the direction F of travel of the machine substantially to the level of the right rear wheel 28 of the tractor 1. This latter arm 5 (not visible in the accompanying drawings) is engaged in a tube or socket 50 (Figure 3) articulated to the left lateral wall 20 of the conditioning passage of the mower-conditioner as described above, and thus 10 permits the said machine to pivot, independently of the tractor 1, about an axis 51 directed in the direction F of travel of the machine when hitched to the tractor in the working position.

15 Without departing from the scope of the present invention, it is quite apparent that the tube or socket 50 constituting the female elements of the assembly permitting connection of the machine according to 20 the invention and the tractor could be connected to the arm 49 of the hitch device 47, while the arm constituting the male element of the said assembly would be fast with the mower-conditioner.

25 When the tractor 1 is moving in the direction F of travel of the machine, the hitch device 47 pushes the machine in the direction indicated by the arrow F because the arm engaged in the tube 50 abuts 30 against the rear extremity of the latter. A catch 52 articulated on the tube 50 permits of preventing the said arm from disengaging itself from the said tube 50, and permits the tractor 1 to drive the machine in 35 reverse.

The tube or socket 50 is fixed beneath the stiffening arm or post 34 to an angle piece 53 articulated to the left lateral wall 20 of the conditioning passage, by means 40 of a horizontal spindle 54 extending perpendicularly of the direction F of travel of the tractor 1. Thus the tube 50 can pivot about this spindle 54 in a plane parallel to that of the outer face of the wall 20 situated 45 opposite to the right rear wheel 28 of the tractor 1. A compensating spring 55, intended to reduce the pressure which the front of the machine, that is its box 11, exerts upon the ground, extends between 50 the chassis 2 of the machine and the tube 50. The travel of the tube 50 is limited downwards by virtue of a stop 56 which likewise retains the tube 50 laterally.

55 In Figure 3 the catch 52 is raised and held in place by a spring 57. Thus the bolt 52 abuts against a stop 58, so that the spring 55 does not pull the tube or socket 50 too high, which would be detrimental to the coupling with the hitch device 47 60 fast with the tractor 1.

Once the coupling is realised, the tube 50 permits the mower-conditioner to oscillate freely in relation to the tractor 1 in a plane perpendicular to its direction F of 65 travel. Thus the machine can follow varia-

tions of ground level independently of the said tractor 1.

On changes of direction of the tractor 1 the orientation of the two arms of the hitch device 47, which are connected rigidly 70 to the tractor 1, is likewise modified. The arm constituting the male element of the hitch device 47 and engaged in the tube 50 exerts a force upon the latter in order to 75 oblige the chassis 2 of the machine to follow a path parallel to that of the tractor 1. In order to prevent these forces from deforming the lateral wall 20 of the conditioning passages, which would affect the 80 alignment of the bearings of the conditioning rotor 15, a second stiffening post 59 is fixed inside and parallel to the said left lateral wall 20, is welded thereto and extends in a vertical plane parallel to that 85 of the post 34, and parallel with the tube 50.

The posts 34 and 59 can perfectly well be constituted by one single piece. Moreover in a modification of the invention it is perfectly possible to fix the tube 50 90 either to the post 59 or to the post 34, or to the post constituted by the assembling of the two parts 34 and 59.

In the foregoing description, the post or posts 34 and 59, the tube 50 and the wheel 95 3 closer to the tractor 1 are situated outside the conditioning passage but on the near side of the trajectory 7 of the cutting elements of the cutting mechanism, in the region where the said trajectory is closest 100 to the tractor 1.

The machine is further provided with a safety rail 60 which extends forward and in particular surrounds the discs 4, in order 105 to prevent their blades 5 from being able to approach too close to certain obstacles such for example as trees.

The mower-conditioner is equipped with a device for hitching in the transport position, distinct from its device 47 for hitching 110 in the working position. The device for hitching in the transport position comprises two elements 61 and 62, of which one element 61 is mounted substantially in the axis of the tractor 1, behind the hitch 115 device 47. The other element 62 is fixed to the rear of the chassis 2 of the mower-conditioner. When it is desired to transport the machine, it is sufficient to couple the 120 two elements 61 and 62 and to raise the machine by means of the three-point lift device of the tractor 1. The two elements 61 and 62 can advantageously be constituted by the male and female elements 125 of a quick-coupling device.

WHAT WE CLAIM IS:—

1. A mower-conditioner of the kind which when in use is hitched laterally beside a tractor and comprises a cutting mechanism and a conditioning mechanism, the latter 130

being provided with a lateral wall (20) which bounds a conditioning passage at that side of this passage where this passage is closest to the tractor when in use, characterised in that a double-output control box (29) and a bearing carrier (33) are carried by the said wall (20), the bearing carrier (33) carries a bearing of a power input pulley (32) drivingly connected by belts (30) to the said control box (29), a stiffening post (34) is connected to the control box (29) and to the bearing carrier (33) for the purpose of resisting deformation of the said wall (20) when the belts (30) are taut, and there is also a tube (50) which is connected to the said wall (20) and forms part of a hitching arrangement by which the mower-conditioner, when in use, is hitched to the tractor in a manner permitting the mower-conditioner to oscillate about an axis (51) extending substantially in the direction (F) in which the mower-conditioner travels when in use.

2. A mower-conditioner according to Claim 1, characterised in that both the post (34) and the tube (50) are situated outside the conditioning passage but on the near side of the trajectory (7) of the cutting elements (5) of the cutting mechanism, in the region where the said trajectory (7) is

closest to the tractor (1).

3. A mower-conditioner according to Claim 1 or 2, characterised in that the tube (50) is situated beneath the post (34).

4. A mower-conditioner according to Claim 1, characterised in that the bearing carrier (33) of the input pulley (32) is articulated to the post (34) connected to the wall (20) of the conditioning passage.

5. A mower-conditioner according to any one of the preceding Claims, characterised in that the post (34) is rigidly connected to the double-output control box (29).

6. A mower-conditioner according to any one of the preceding Claims, characterised in that the tube (50) is fixed to the lateral wall (20) of the conditioning passage.

7. A mower-conditioner according to any one of Claims 1 to 5, characterised in that the tube (50) is fixed to the post (34), (59).

8. A mower-conditioner comprising a cutting mechanism and a conditioning mechanism, substantially as hereinbefore described with reference to, and as shown in, the accompanying drawings.

HANS & DANIELSSON,
Chartered Patent Agents,
34 Tavistock Street,
London, WC2E 7PB.

1594776

COMPLETE SPECIFICATION

3 SHEETS

This drawing is a reproduction of the Original on a reduced scale

Sheet 1

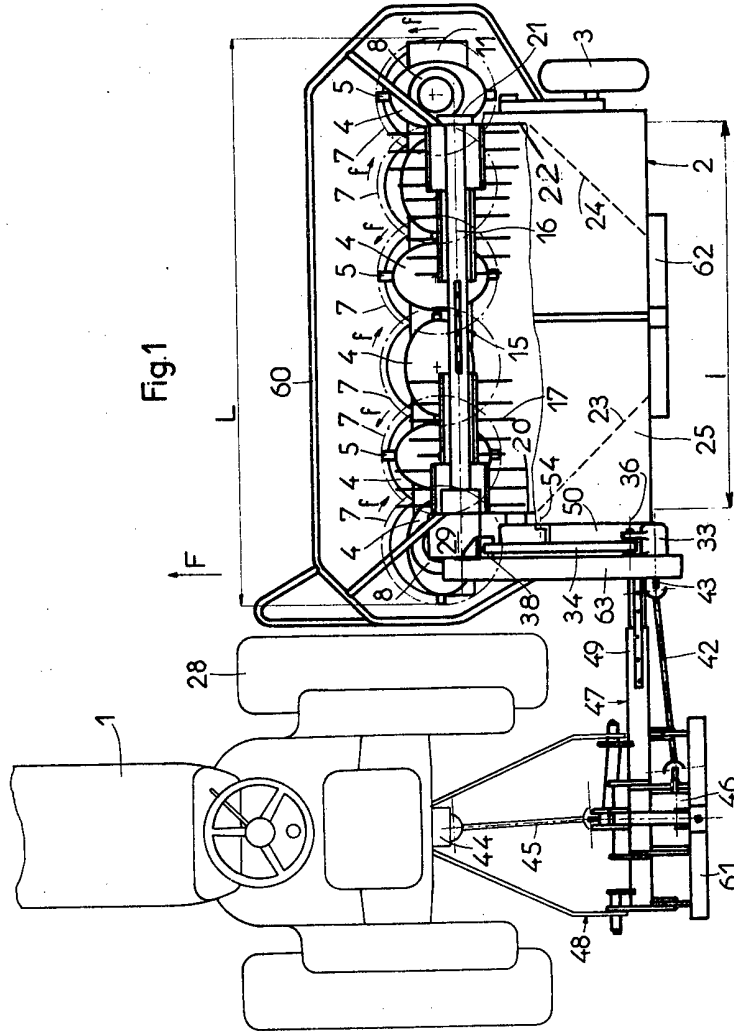

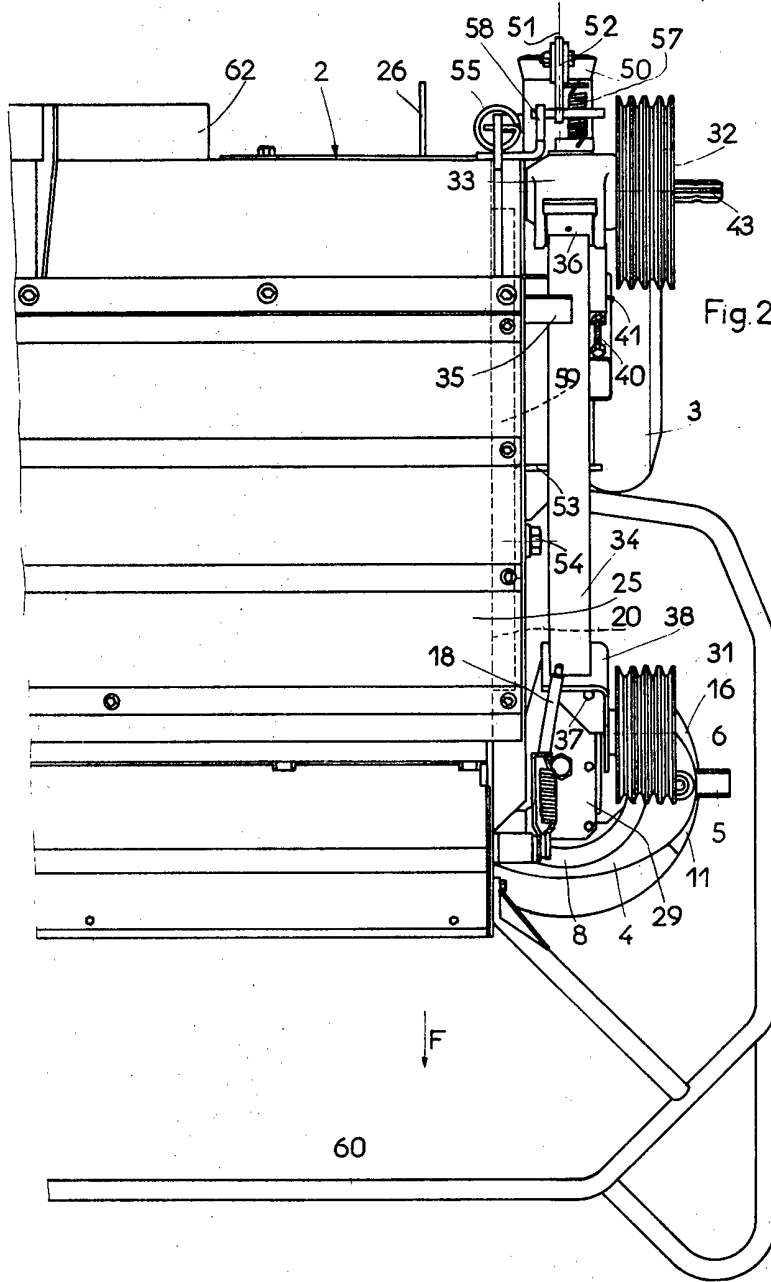

1594776

COMPLETE SPECIFICATION

3 SHEETS

This drawing is a reproduction of the Original on a reduced scale

Sheet 3

