



(12) **United States Design Patent**
Williams Barnett et al.

(10) **Patent No.:** **US D924,170 S**
(45) **Date of Patent:** **** Jul. 6, 2021**

- (54) **ELECTRICAL CONNECTOR**
- (71) Applicant: **Samtec, Inc.**, New Albany, IN (US)
- (72) Inventors: **Jean Karlo Williams Barnett**, New Albany, IN (US); **Jignesh H. Shah**, Santa Clara, CA (US); **Eric Zbinden**, Santa Clara, CA (US)
- (73) Assignee: **SAMTEC, INC.**, New Albany, IN (US)
- (**) Term: **15 Years**
- (21) Appl. No.: **29/733,196**
- (22) Filed: **Apr. 30, 2020**

Related U.S. Application Data

- (62) Division of application No. 29/628,702, filed on Dec. 6, 2017, now Pat. No. Des. 886,066.
- (51) **LOC (13) Cl.** **13-03**
- (52) **U.S. Cl.** **D13/147**
- (58) **Field of Classification Search**
- USPC D13/133, 146, 147, 154, 184, 199
- CPC H01R 9/075; H01R 9/16; H01R 12/616; H01R 13/05; H01R 13/193; H01R 13/2464; H01R 13/2478; H01R 13/2485; H01R

(Continued)

(56) **References Cited**

U.S. PATENT DOCUMENTS

- 2,760,174 A 8/1956 Burt et al.
- 4,477,142 A 10/1984 Cooper et al.

(Continued)

FOREIGN PATENT DOCUMENTS

- CN 102780103 A 11/2012
- CN 204243357 U 4/2015

(Continued)

Primary Examiner — Shawn T Gingrich
(74) *Attorney, Agent, or Firm* — BakerHostetler

(57) **CLAIM**

The ornamental design for an electrical connector, as shown and described.

DESCRIPTION

FIG. 1 is a top, left, front perspective view of an electrical connector according to one embodiment of our design; FIG. 2 is another top, left, front perspective view thereof; FIG. 3 is a bottom, right, rear perspective view of thereof; FIG. 4 is another bottom, right, rear perspective view of thereof; FIG. 5 is a front elevation view thereof; FIG. 6 is a rear elevation view thereof; FIG. 7 is a right side elevation view thereof; FIG. 8 is a left side elevation view thereof; FIG. 9 is a top plan view thereof; FIG. 10 is a bottom plan view thereof; FIG. 11 is a top, left, front perspective view of an electrical connector according to another embodiment of our design; FIG. 12 is another top, left, front perspective view thereof; FIG. 13 is a bottom, right, rear perspective view of thereof; FIG. 14 is another bottom, right, rear perspective view of thereof; FIG. 15 is a front elevation view thereof; FIG. 16 is a rear elevation view thereof; FIG. 17 is a left side elevation view thereof; FIG. 18 is a right side elevation view thereof; FIG. 19 is a top plan view thereof; and, FIG. 20 is a bottom plan view thereof.

The broken line portion in the drawings illustrate portions of the electrical connector that form no part of the claimed design.

1 Claim, 12 Drawing Sheets

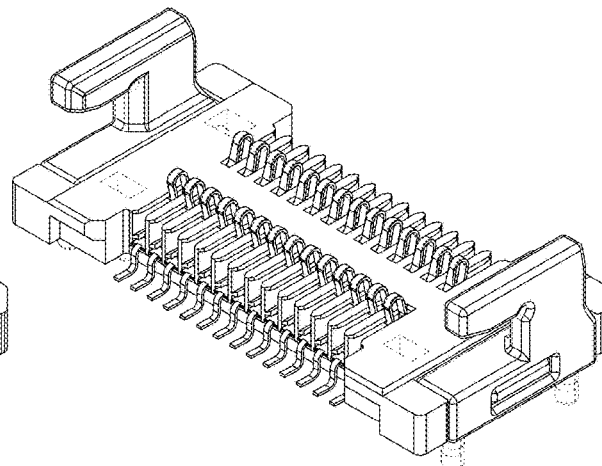
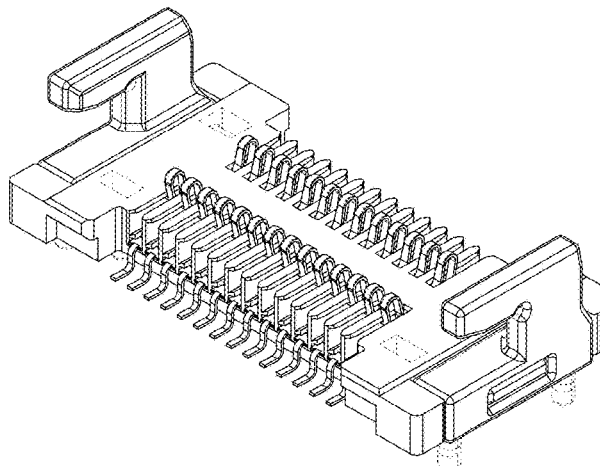

US D924,170 S

<p>(58) Field of Classification Search CPC 13/2492; H01R 13/6271; H01R 13/6275; H01R 13/6335; H01R 13/642; H01R 13/659; H01R 12/00; H01R 13/60; H01R 13/62; H01R 13/627 See application file for complete search history.</p>	<table border="0" style="width: 100%; border-collapse: collapse;"> <tr><td>10,367,282</td><td>B2</td><td>7/2019</td><td>Harmon et al.</td><td></td></tr> <tr><td>D860,140</td><td>S</td><td>9/2019</td><td>Wu</td><td></td></tr> <tr><td>D886,066</td><td>S *</td><td>6/2020</td><td>Williams Barnett</td><td>..... D13/154</td></tr> <tr><td>2002/0052131</td><td>A1</td><td>5/2002</td><td>Hashimoto</td><td></td></tr> <tr><td>2007/0218759</td><td>A1</td><td>9/2007</td><td>Liang et al.</td><td></td></tr> <tr><td>2008/0222351</td><td>A1</td><td>9/2008</td><td>Verdiell et al.</td><td></td></tr> <tr><td>2009/0305528</td><td>A1*</td><td>12/2009</td><td>Hirata</td><td>..... H01R 12/716 439/74</td></tr> <tr><td>2010/0120268</td><td>A1</td><td>5/2010</td><td>Cheng-Chi</td><td></td></tr> <tr><td>2010/0130044</td><td>A1*</td><td>5/2010</td><td>Taketomi</td><td>..... H01R 12/88 439/260</td></tr> <tr><td>2011/0123150</td><td>A1</td><td>5/2011</td><td>Zbinden et al.</td><td></td></tr> <tr><td>2011/0123151</td><td>A1</td><td>5/2011</td><td>Zbinden et al.</td><td></td></tr> <tr><td>2012/0257360</td><td>A1</td><td>10/2012</td><td>Sun</td><td></td></tr> <tr><td>2012/0289066</td><td>A1*</td><td>11/2012</td><td>Wang</td><td>..... H01R 12/83 439/65</td></tr> <tr><td>2013/0004120</td><td>A1</td><td>1/2013</td><td>Zbinden et al.</td><td></td></tr> <tr><td>2013/0129346</td><td>A1</td><td>5/2013</td><td>Zbinden et al.</td><td></td></tr> <tr><td>2013/0148973</td><td>A1</td><td>6/2013</td><td>Zbinden et al.</td><td></td></tr> <tr><td>2013/0344710</td><td>A1*</td><td>12/2013</td><td>Sasaki</td><td>..... H01R 12/716 439/65</td></tr> <tr><td>2014/0017914</td><td>A1*</td><td>1/2014</td><td>Endo</td><td>..... H01R 9/00 439/81</td></tr> <tr><td>2014/0082977</td><td>A1</td><td>3/2014</td><td>Pilon</td><td></td></tr> <tr><td>2014/0161407</td><td>A1</td><td>6/2014</td><td>Lee et al.</td><td></td></tr> <tr><td>2015/0357734</td><td>A1</td><td>12/2015</td><td>Copper et al.</td><td></td></tr> <tr><td>2015/0364865</td><td>A1</td><td>12/2015</td><td>Sutter et al.</td><td></td></tr> <tr><td>2016/0079692</td><td>A1</td><td>3/2016</td><td>Sasame et al.</td><td></td></tr> <tr><td>2017/0062963</td><td>A1</td><td>3/2017</td><td>Tagami et al.</td><td></td></tr> <tr><td>2017/0174167</td><td>A1</td><td>6/2017</td><td>Collazo Gomez</td><td></td></tr> <tr><td>2020/0185849</td><td>A1*</td><td>6/2020</td><td>Chi</td><td>..... H01R 12/88</td></tr> <tr><td>2020/0220286</td><td>A1</td><td>7/2020</td><td>Bettman et al.</td><td></td></tr> </table>	10,367,282	B2	7/2019	Harmon et al.		D860,140	S	9/2019	Wu		D886,066	S *	6/2020	Williams Barnett D13/154	2002/0052131	A1	5/2002	Hashimoto		2007/0218759	A1	9/2007	Liang et al.		2008/0222351	A1	9/2008	Verdiell et al.		2009/0305528	A1*	12/2009	Hirata H01R 12/716 439/74	2010/0120268	A1	5/2010	Cheng-Chi		2010/0130044	A1*	5/2010	Taketomi H01R 12/88 439/260	2011/0123150	A1	5/2011	Zbinden et al.		2011/0123151	A1	5/2011	Zbinden et al.		2012/0257360	A1	10/2012	Sun		2012/0289066	A1*	11/2012	Wang H01R 12/83 439/65	2013/0004120	A1	1/2013	Zbinden et al.		2013/0129346	A1	5/2013	Zbinden et al.		2013/0148973	A1	6/2013	Zbinden et al.		2013/0344710	A1*	12/2013	Sasaki H01R 12/716 439/65	2014/0017914	A1*	1/2014	Endo H01R 9/00 439/81	2014/0082977	A1	3/2014	Pilon		2014/0161407	A1	6/2014	Lee et al.		2015/0357734	A1	12/2015	Copper et al.		2015/0364865	A1	12/2015	Sutter et al.		2016/0079692	A1	3/2016	Sasame et al.		2017/0062963	A1	3/2017	Tagami et al.		2017/0174167	A1	6/2017	Collazo Gomez		2020/0185849	A1*	6/2020	Chi H01R 12/88	2020/0220286	A1	7/2020	Bettman et al.																																																																							
10,367,282	B2	7/2019	Harmon et al.																																																																																																																																																																																																											
D860,140	S	9/2019	Wu																																																																																																																																																																																																											
D886,066	S *	6/2020	Williams Barnett D13/154																																																																																																																																																																																																										
2002/0052131	A1	5/2002	Hashimoto																																																																																																																																																																																																											
2007/0218759	A1	9/2007	Liang et al.																																																																																																																																																																																																											
2008/0222351	A1	9/2008	Verdiell et al.																																																																																																																																																																																																											
2009/0305528	A1*	12/2009	Hirata H01R 12/716 439/74																																																																																																																																																																																																										
2010/0120268	A1	5/2010	Cheng-Chi																																																																																																																																																																																																											
2010/0130044	A1*	5/2010	Taketomi H01R 12/88 439/260																																																																																																																																																																																																										
2011/0123150	A1	5/2011	Zbinden et al.																																																																																																																																																																																																											
2011/0123151	A1	5/2011	Zbinden et al.																																																																																																																																																																																																											
2012/0257360	A1	10/2012	Sun																																																																																																																																																																																																											
2012/0289066	A1*	11/2012	Wang H01R 12/83 439/65																																																																																																																																																																																																										
2013/0004120	A1	1/2013	Zbinden et al.																																																																																																																																																																																																											
2013/0129346	A1	5/2013	Zbinden et al.																																																																																																																																																																																																											
2013/0148973	A1	6/2013	Zbinden et al.																																																																																																																																																																																																											
2013/0344710	A1*	12/2013	Sasaki H01R 12/716 439/65																																																																																																																																																																																																										
2014/0017914	A1*	1/2014	Endo H01R 9/00 439/81																																																																																																																																																																																																										
2014/0082977	A1	3/2014	Pilon																																																																																																																																																																																																											
2014/0161407	A1	6/2014	Lee et al.																																																																																																																																																																																																											
2015/0357734	A1	12/2015	Copper et al.																																																																																																																																																																																																											
2015/0364865	A1	12/2015	Sutter et al.																																																																																																																																																																																																											
2016/0079692	A1	3/2016	Sasame et al.																																																																																																																																																																																																											
2017/0062963	A1	3/2017	Tagami et al.																																																																																																																																																																																																											
2017/0174167	A1	6/2017	Collazo Gomez																																																																																																																																																																																																											
2020/0185849	A1*	6/2020	Chi H01R 12/88																																																																																																																																																																																																										
2020/0220286	A1	7/2020	Bettman et al.																																																																																																																																																																																																											
<p>(56) References Cited U.S. PATENT DOCUMENTS</p>																																																																																																																																																																																																														
<table border="0" style="width: 100%; border-collapse: collapse;"> <tr><td>4,544,225</td><td>A</td><td>10/1985</td><td>Raus et al.</td><td></td></tr> <tr><td>4,639,063</td><td>A</td><td>1/1987</td><td>Mueller</td><td></td></tr> <tr><td>4,678,252</td><td>A</td><td>7/1987</td><td>Moore</td><td></td></tr> <tr><td>5,167,523</td><td>A</td><td>12/1992</td><td>Crimmins et al.</td><td></td></tr> <tr><td>5,224,873</td><td>A</td><td>7/1993</td><td>Duffet et al.</td><td></td></tr> <tr><td>5,396,402</td><td>A</td><td>3/1995</td><td>Perugini et al.</td><td></td></tr> <tr><td>5,462,441</td><td>A</td><td>10/1995</td><td>Renn et al.</td><td></td></tr> <tr><td>5,507,657</td><td>A</td><td>4/1996</td><td>Seto et al.</td><td></td></tr> <tr><td>5,722,849</td><td>A</td><td>3/1998</td><td>Alwine</td><td></td></tr> <tr><td>5,775,957</td><td>A</td><td>7/1998</td><td>Fink et al.</td><td></td></tr> <tr><td>6,048,221</td><td>A</td><td>4/2000</td><td>McCleerey et al.</td><td></td></tr> <tr><td>6,176,725</td><td>B1</td><td>1/2001</td><td>Kobayashi et al.</td><td></td></tr> <tr><td>6,638,105</td><td>B1</td><td>10/2003</td><td>Wu</td><td></td></tr> <tr><td>7,001,200</td><td>B2</td><td>2/2006</td><td>Yoshie</td><td></td></tr> <tr><td>D528,985</td><td>S *</td><td>9/2006</td><td>Peng</td><td>..... D13/147</td></tr> <tr><td>D529,443</td><td>S *</td><td>10/2006</td><td>Chien</td><td>..... D13/147</td></tr> <tr><td>7,134,895</td><td>B1</td><td>11/2006</td><td>Choy et al.</td><td></td></tr> <tr><td>7,329,054</td><td>B1</td><td>2/2008</td><td>Epitiaux et al.</td><td></td></tr> <tr><td>7,479,017</td><td>B1</td><td>1/2009</td><td>Koopman et al.</td><td></td></tr> <tr><td>D589,891</td><td>S *</td><td>4/2009</td><td>Peng</td><td>..... D13/147</td></tr> <tr><td>D589,901</td><td>S</td><td>4/2009</td><td>Peng et al.</td><td></td></tr> <tr><td>7,648,287</td><td>B2</td><td>1/2010</td><td>Epitiaux et al.</td><td></td></tr> <tr><td>7,682,179</td><td>B1</td><td>3/2010</td><td>Tsai</td><td></td></tr> <tr><td>7,766,559</td><td>B2</td><td>8/2010</td><td>Epitiaux et al.</td><td></td></tr> <tr><td>7,824,112</td><td>B2</td><td>11/2010</td><td>Epitiaux et al.</td><td></td></tr> <tr><td>8,057,248</td><td>B1</td><td>11/2011</td><td>Sherman</td><td></td></tr> <tr><td>D697,031</td><td>S *</td><td>1/2014</td><td>Yoshisuji</td><td>..... D13/147</td></tr> <tr><td>D708,145</td><td>S</td><td>7/2014</td><td>McCartin et al.</td><td></td></tr> <tr><td>D708,580</td><td>S</td><td>7/2014</td><td>McCartin et al.</td><td></td></tr> <tr><td>D721,332</td><td>S</td><td>1/2015</td><td>Yokoo</td><td></td></tr> <tr><td>D722,968</td><td>S *</td><td>2/2015</td><td>Takemoto</td><td>..... D13/147</td></tr> <tr><td>D729,173</td><td>S *</td><td>5/2015</td><td>Fukumoto</td><td>..... D13/147</td></tr> <tr><td>D736,714</td><td>S</td><td>8/2015</td><td>Mongold et al.</td><td></td></tr> <tr><td>9,246,280</td><td>B2</td><td>1/2016</td><td>Neer et al.</td><td></td></tr> <tr><td>9,374,165</td><td>B2</td><td>6/2016</td><td>Zbinden et al.</td><td></td></tr> <tr><td>D800,070</td><td>S *</td><td>10/2017</td><td>Manba</td><td>..... D13/147</td></tr> <tr><td>D820,216</td><td>S *</td><td>6/2018</td><td>Wu</td><td>..... D13/147</td></tr> <tr><td>D822,611</td><td>S *</td><td>7/2018</td><td>Bettman</td><td>..... D13/147</td></tr> <tr><td>D835,048</td><td>S *</td><td>12/2018</td><td>Arai</td><td>..... D13/147</td></tr> <tr><td>10,290,962</td><td>B2</td><td>5/2019</td><td>Harmon</td><td></td></tr> <tr><td>10,297,963</td><td>B2</td><td>5/2019</td><td>Herring et al.</td><td></td></tr> </table>	4,544,225	A	10/1985	Raus et al.		4,639,063	A	1/1987	Mueller		4,678,252	A	7/1987	Moore		5,167,523	A	12/1992	Crimmins et al.		5,224,873	A	7/1993	Duffet et al.		5,396,402	A	3/1995	Perugini et al.		5,462,441	A	10/1995	Renn et al.		5,507,657	A	4/1996	Seto et al.		5,722,849	A	3/1998	Alwine		5,775,957	A	7/1998	Fink et al.		6,048,221	A	4/2000	McCleerey et al.		6,176,725	B1	1/2001	Kobayashi et al.		6,638,105	B1	10/2003	Wu		7,001,200	B2	2/2006	Yoshie		D528,985	S *	9/2006	Peng D13/147	D529,443	S *	10/2006	Chien D13/147	7,134,895	B1	11/2006	Choy et al.		7,329,054	B1	2/2008	Epitiaux et al.		7,479,017	B1	1/2009	Koopman et al.		D589,891	S *	4/2009	Peng D13/147	D589,901	S	4/2009	Peng et al.		7,648,287	B2	1/2010	Epitiaux et al.		7,682,179	B1	3/2010	Tsai		7,766,559	B2	8/2010	Epitiaux et al.		7,824,112	B2	11/2010	Epitiaux et al.		8,057,248	B1	11/2011	Sherman		D697,031	S *	1/2014	Yoshisuji D13/147	D708,145	S	7/2014	McCartin et al.		D708,580	S	7/2014	McCartin et al.		D721,332	S	1/2015	Yokoo		D722,968	S *	2/2015	Takemoto D13/147	D729,173	S *	5/2015	Fukumoto D13/147	D736,714	S	8/2015	Mongold et al.		9,246,280	B2	1/2016	Neer et al.		9,374,165	B2	6/2016	Zbinden et al.		D800,070	S *	10/2017	Manba D13/147	D820,216	S *	6/2018	Wu D13/147	D822,611	S *	7/2018	Bettman D13/147	D835,048	S *	12/2018	Arai D13/147	10,290,962	B2	5/2019	Harmon		10,297,963	B2	5/2019	Herring et al.		
4,544,225	A	10/1985	Raus et al.																																																																																																																																																																																																											
4,639,063	A	1/1987	Mueller																																																																																																																																																																																																											
4,678,252	A	7/1987	Moore																																																																																																																																																																																																											
5,167,523	A	12/1992	Crimmins et al.																																																																																																																																																																																																											
5,224,873	A	7/1993	Duffet et al.																																																																																																																																																																																																											
5,396,402	A	3/1995	Perugini et al.																																																																																																																																																																																																											
5,462,441	A	10/1995	Renn et al.																																																																																																																																																																																																											
5,507,657	A	4/1996	Seto et al.																																																																																																																																																																																																											
5,722,849	A	3/1998	Alwine																																																																																																																																																																																																											
5,775,957	A	7/1998	Fink et al.																																																																																																																																																																																																											
6,048,221	A	4/2000	McCleerey et al.																																																																																																																																																																																																											
6,176,725	B1	1/2001	Kobayashi et al.																																																																																																																																																																																																											
6,638,105	B1	10/2003	Wu																																																																																																																																																																																																											
7,001,200	B2	2/2006	Yoshie																																																																																																																																																																																																											
D528,985	S *	9/2006	Peng D13/147																																																																																																																																																																																																										
D529,443	S *	10/2006	Chien D13/147																																																																																																																																																																																																										
7,134,895	B1	11/2006	Choy et al.																																																																																																																																																																																																											
7,329,054	B1	2/2008	Epitiaux et al.																																																																																																																																																																																																											
7,479,017	B1	1/2009	Koopman et al.																																																																																																																																																																																																											
D589,891	S *	4/2009	Peng D13/147																																																																																																																																																																																																										
D589,901	S	4/2009	Peng et al.																																																																																																																																																																																																											
7,648,287	B2	1/2010	Epitiaux et al.																																																																																																																																																																																																											
7,682,179	B1	3/2010	Tsai																																																																																																																																																																																																											
7,766,559	B2	8/2010	Epitiaux et al.																																																																																																																																																																																																											
7,824,112	B2	11/2010	Epitiaux et al.																																																																																																																																																																																																											
8,057,248	B1	11/2011	Sherman																																																																																																																																																																																																											
D697,031	S *	1/2014	Yoshisuji D13/147																																																																																																																																																																																																										
D708,145	S	7/2014	McCartin et al.																																																																																																																																																																																																											
D708,580	S	7/2014	McCartin et al.																																																																																																																																																																																																											
D721,332	S	1/2015	Yokoo																																																																																																																																																																																																											
D722,968	S *	2/2015	Takemoto D13/147																																																																																																																																																																																																										
D729,173	S *	5/2015	Fukumoto D13/147																																																																																																																																																																																																										
D736,714	S	8/2015	Mongold et al.																																																																																																																																																																																																											
9,246,280	B2	1/2016	Neer et al.																																																																																																																																																																																																											
9,374,165	B2	6/2016	Zbinden et al.																																																																																																																																																																																																											
D800,070	S *	10/2017	Manba D13/147																																																																																																																																																																																																										
D820,216	S *	6/2018	Wu D13/147																																																																																																																																																																																																										
D822,611	S *	7/2018	Bettman D13/147																																																																																																																																																																																																										
D835,048	S *	12/2018	Arai D13/147																																																																																																																																																																																																										
10,290,962	B2	5/2019	Harmon																																																																																																																																																																																																											
10,297,963	B2	5/2019	Herring et al.																																																																																																																																																																																																											
	<p style="text-align: center;">FOREIGN PATENT DOCUMENTS</p> <table border="0" style="width: 100%; border-collapse: collapse;"> <tr><td>CN</td><td>104810683</td><td>A</td><td>7/2015</td><td></td></tr> <tr><td>CN</td><td>204668509</td><td>U</td><td>9/2015</td><td></td></tr> <tr><td>CN</td><td>105514708</td><td>A</td><td>4/2016</td><td></td></tr> <tr><td>CN</td><td>105655784</td><td>A</td><td>6/2016</td><td></td></tr> <tr><td>CN</td><td>207765710</td><td>U</td><td>8/2018</td><td></td></tr> <tr><td>JP</td><td>2002-093495</td><td>A</td><td>3/2002</td><td></td></tr> <tr><td>JP</td><td>2011-222273</td><td>A</td><td>11/2011</td><td></td></tr> <tr><td>KR</td><td>10-2015-0044212</td><td>A</td><td>4/2015</td><td></td></tr> <tr><td>KR</td><td>10-2016-0071753</td><td>A</td><td>6/2016</td><td></td></tr> <tr><td>TW</td><td>1223479</td><td>B</td><td>11/2004</td><td></td></tr> <tr><td>TW</td><td>D164746</td><td></td><td>12/2014</td><td></td></tr> <tr><td>TW</td><td>D183201</td><td></td><td>8/2016</td><td></td></tr> <tr><td>TW</td><td>D180510</td><td></td><td>1/2017</td><td></td></tr> <tr><td>TW</td><td>D184085</td><td></td><td>7/2017</td><td></td></tr> <tr><td>WO</td><td>2018/035108</td><td></td><td>2/2018</td><td></td></tr> </table>	CN	104810683	A	7/2015		CN	204668509	U	9/2015		CN	105514708	A	4/2016		CN	105655784	A	6/2016		CN	207765710	U	8/2018		JP	2002-093495	A	3/2002		JP	2011-222273	A	11/2011		KR	10-2015-0044212	A	4/2015		KR	10-2016-0071753	A	6/2016		TW	1223479	B	11/2004		TW	D164746		12/2014		TW	D183201		8/2016		TW	D180510		1/2017		TW	D184085		7/2017		WO	2018/035108		2/2018																																																																																																																																			
CN	104810683	A	7/2015																																																																																																																																																																																																											
CN	204668509	U	9/2015																																																																																																																																																																																																											
CN	105514708	A	4/2016																																																																																																																																																																																																											
CN	105655784	A	6/2016																																																																																																																																																																																																											
CN	207765710	U	8/2018																																																																																																																																																																																																											
JP	2002-093495	A	3/2002																																																																																																																																																																																																											
JP	2011-222273	A	11/2011																																																																																																																																																																																																											
KR	10-2015-0044212	A	4/2015																																																																																																																																																																																																											
KR	10-2016-0071753	A	6/2016																																																																																																																																																																																																											
TW	1223479	B	11/2004																																																																																																																																																																																																											
TW	D164746		12/2014																																																																																																																																																																																																											
TW	D183201		8/2016																																																																																																																																																																																																											
TW	D180510		1/2017																																																																																																																																																																																																											
TW	D184085		7/2017																																																																																																																																																																																																											
WO	2018/035108		2/2018																																																																																																																																																																																																											
	<p>* cited by examiner</p>																																																																																																																																																																																																													

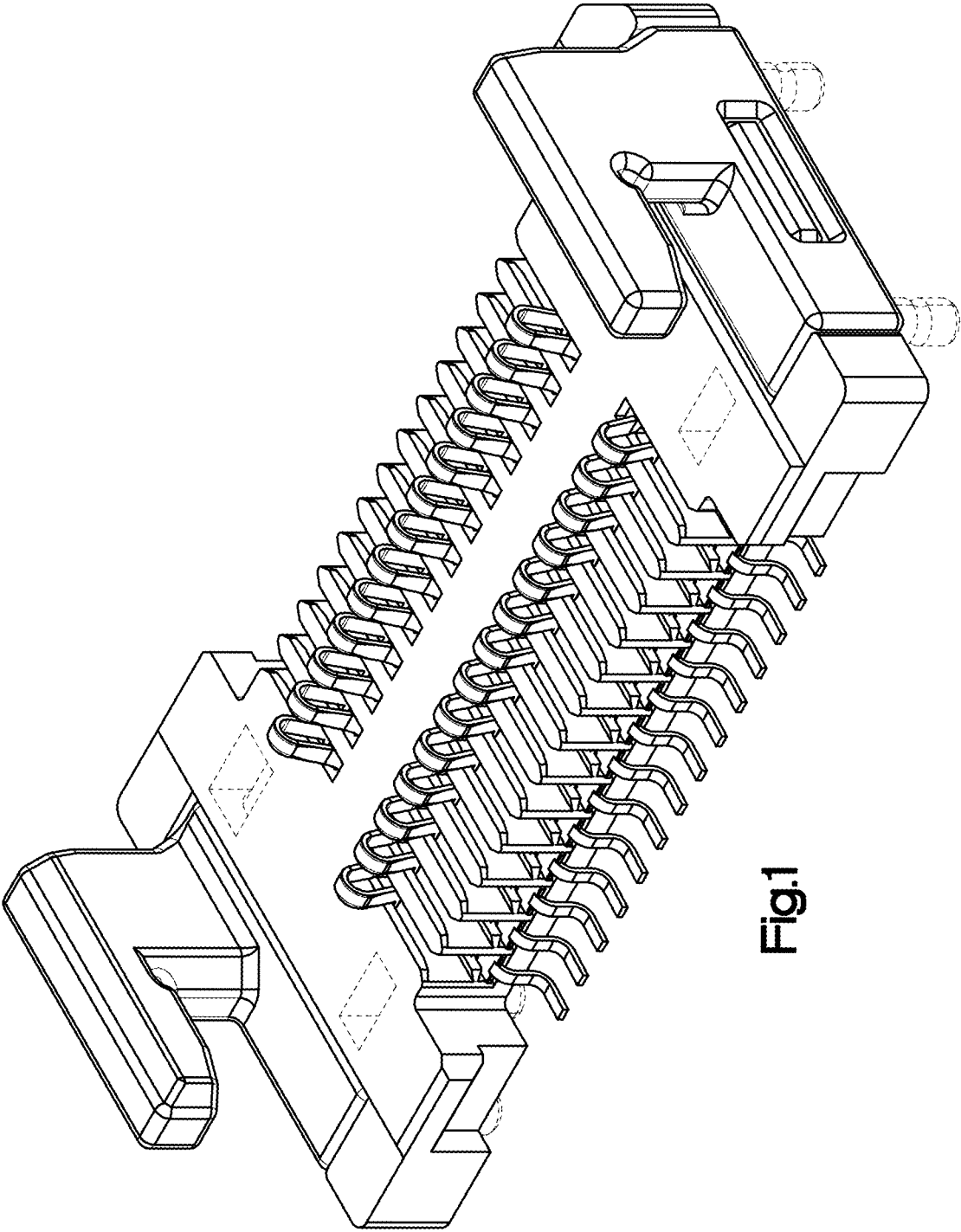

Fig.1

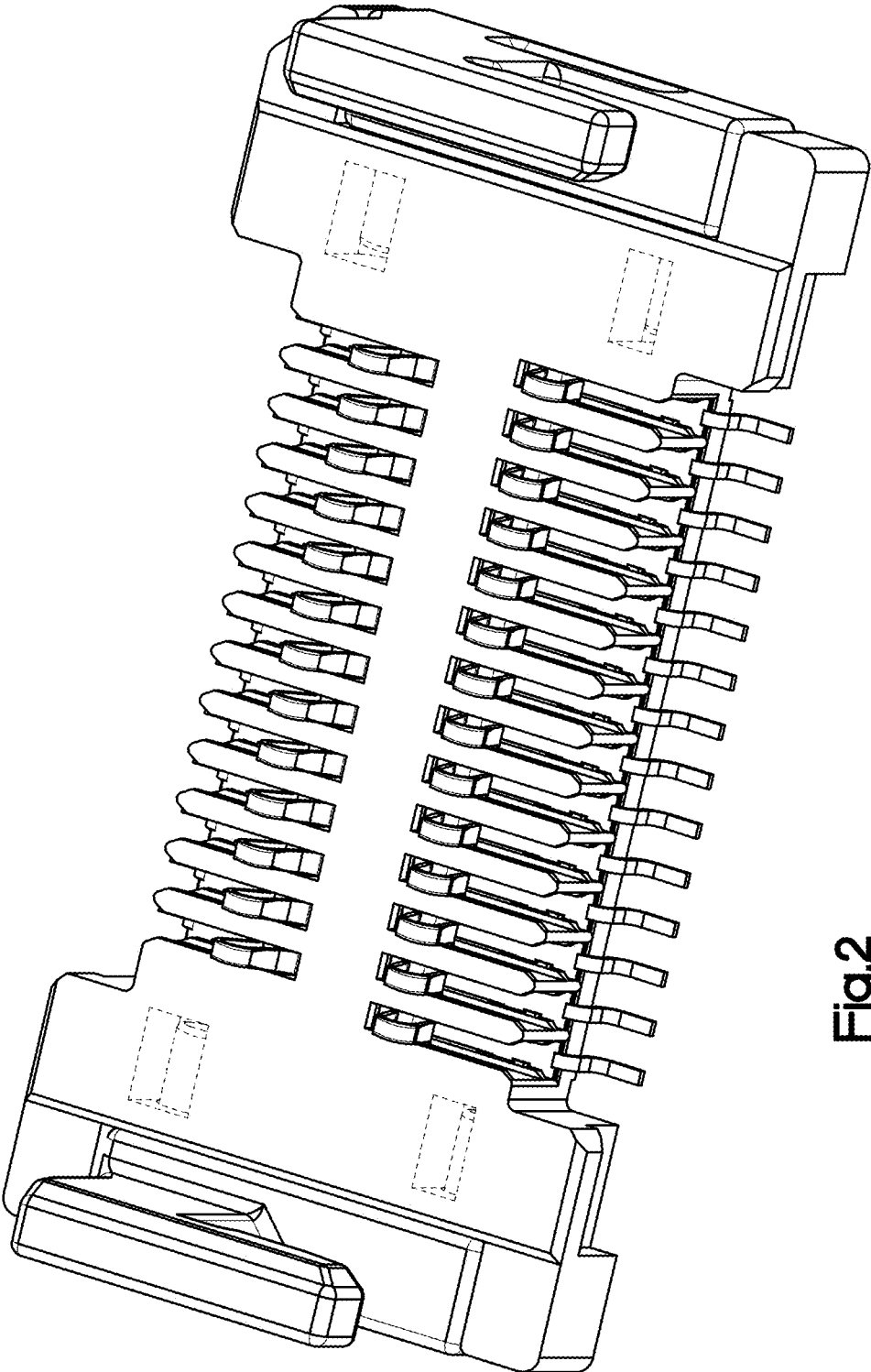

Fig.2

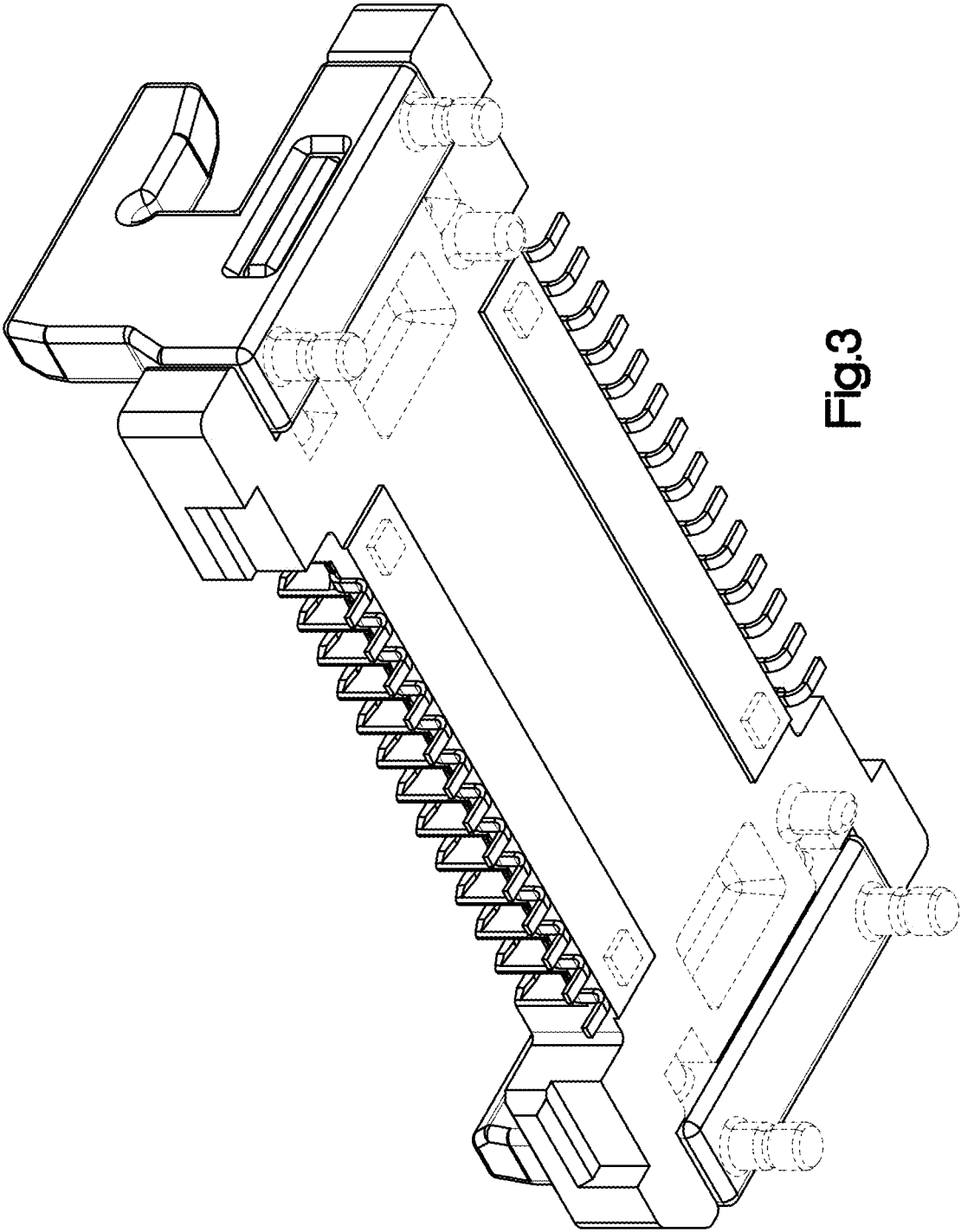

Fig.3

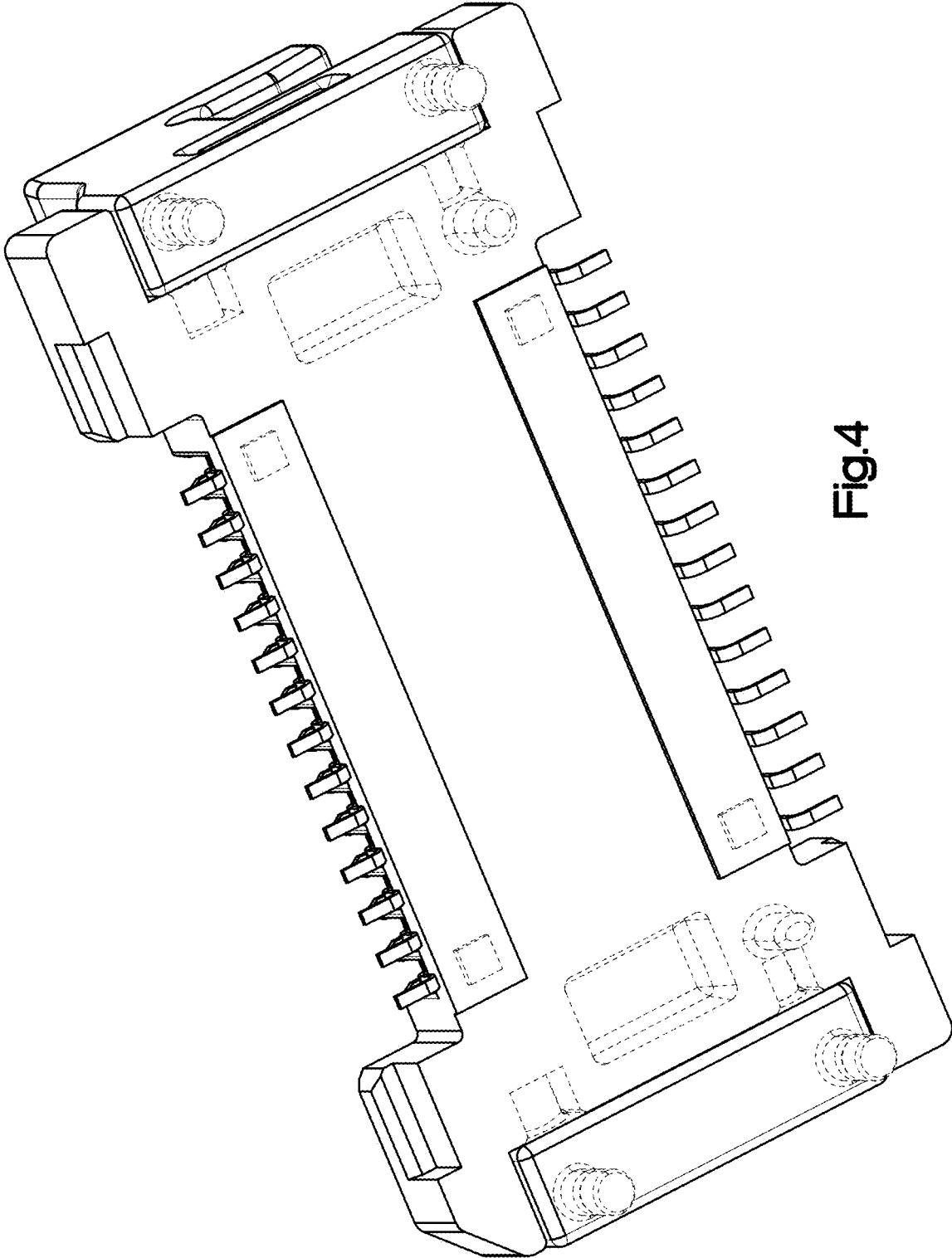

Fig.4

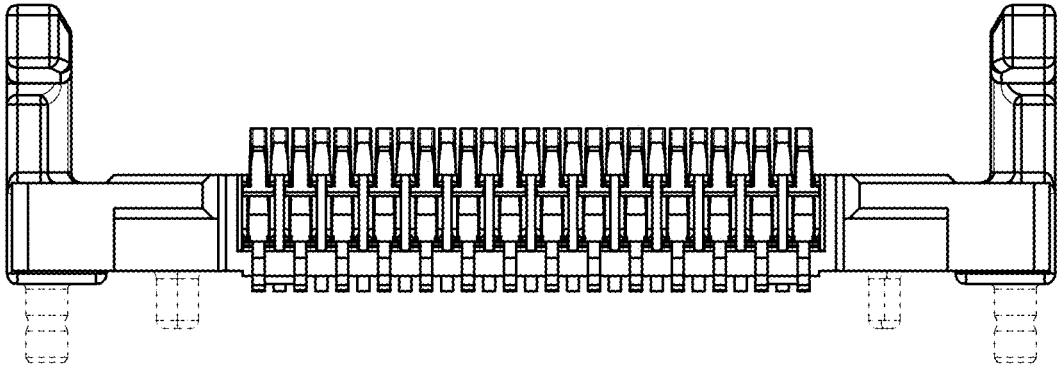

Fig.5

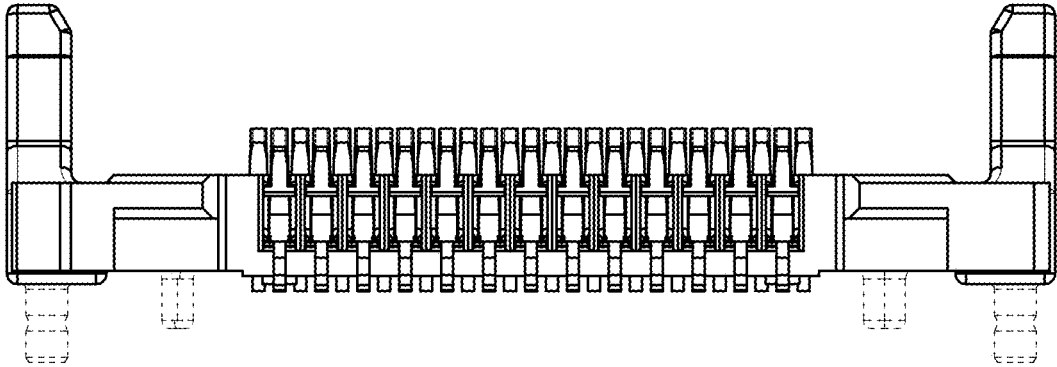

Fig.6

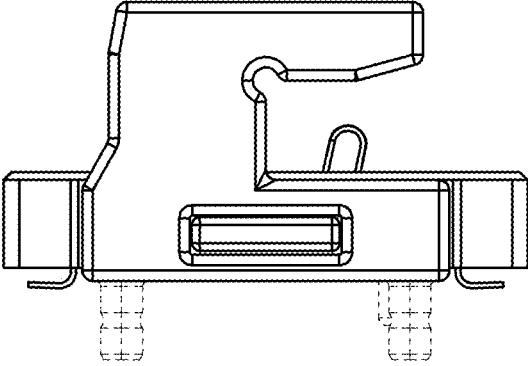

Fig.7

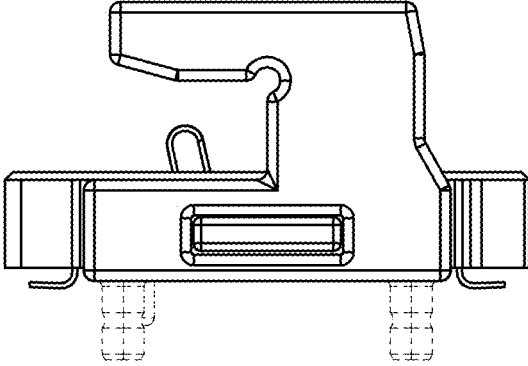

Fig.8

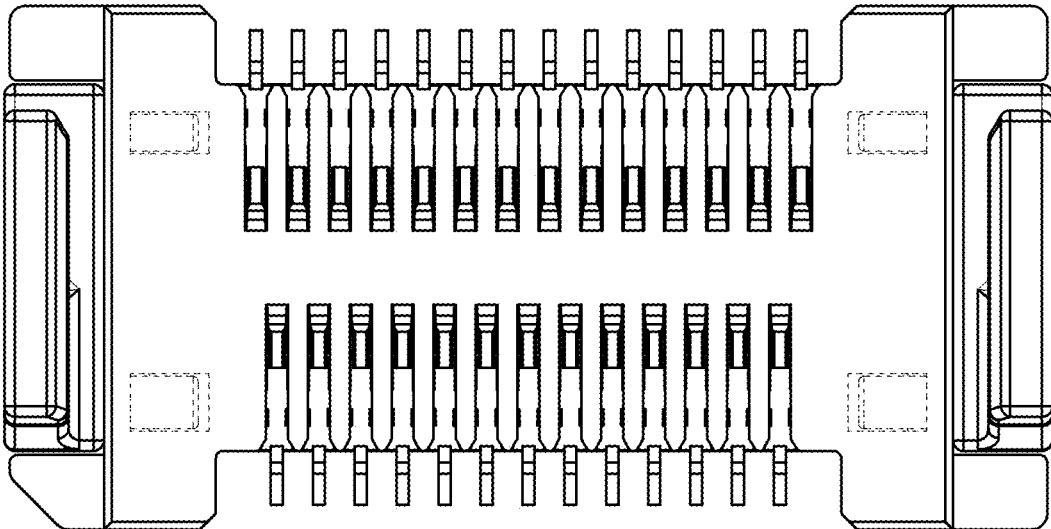

Fig.9

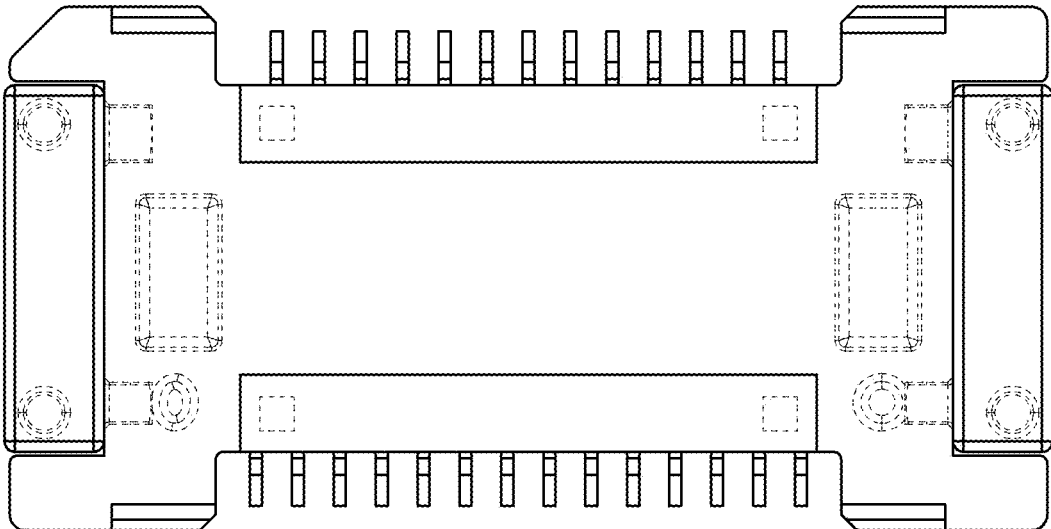

Fig.10

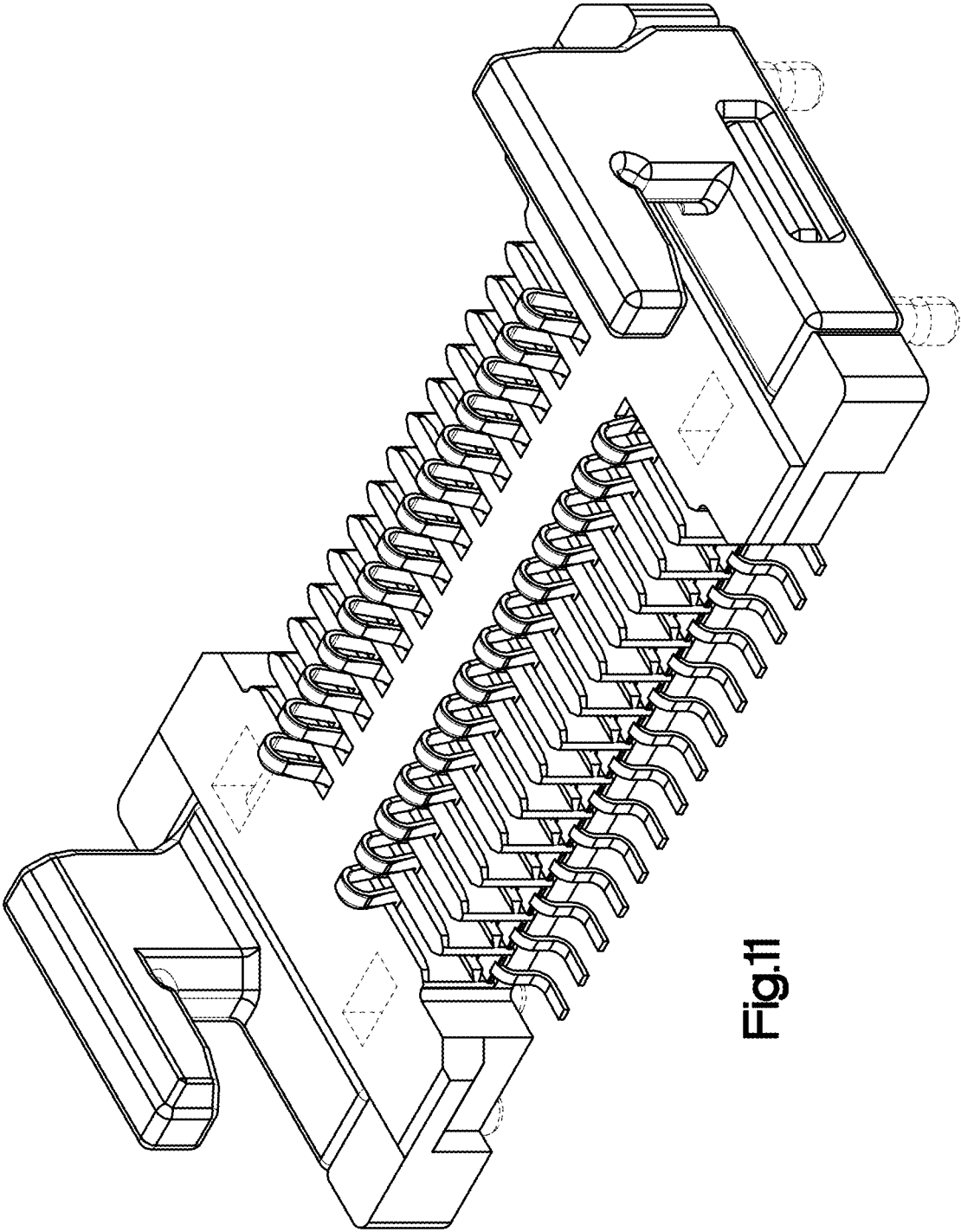

Fig.11

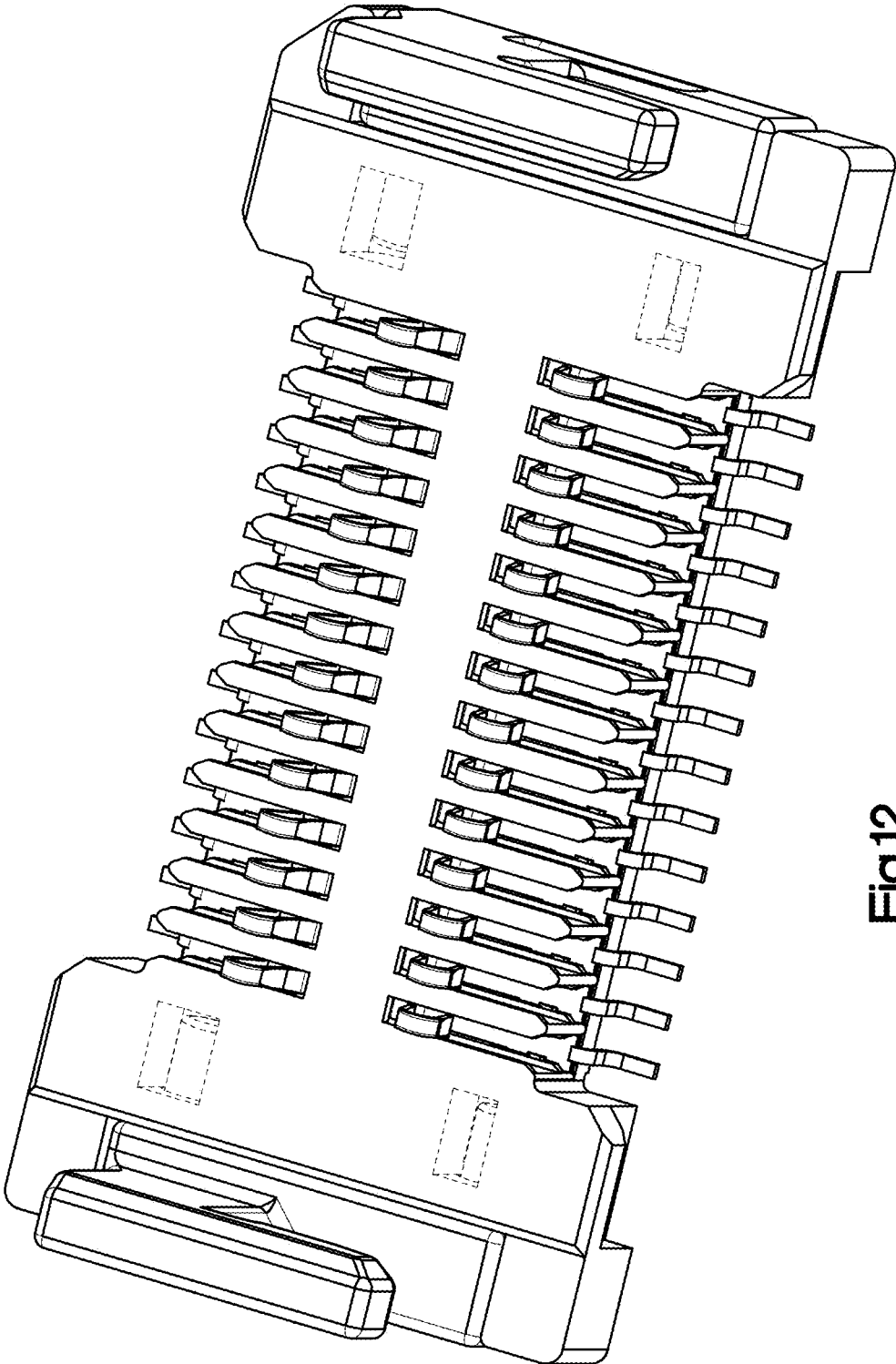

Fig.12

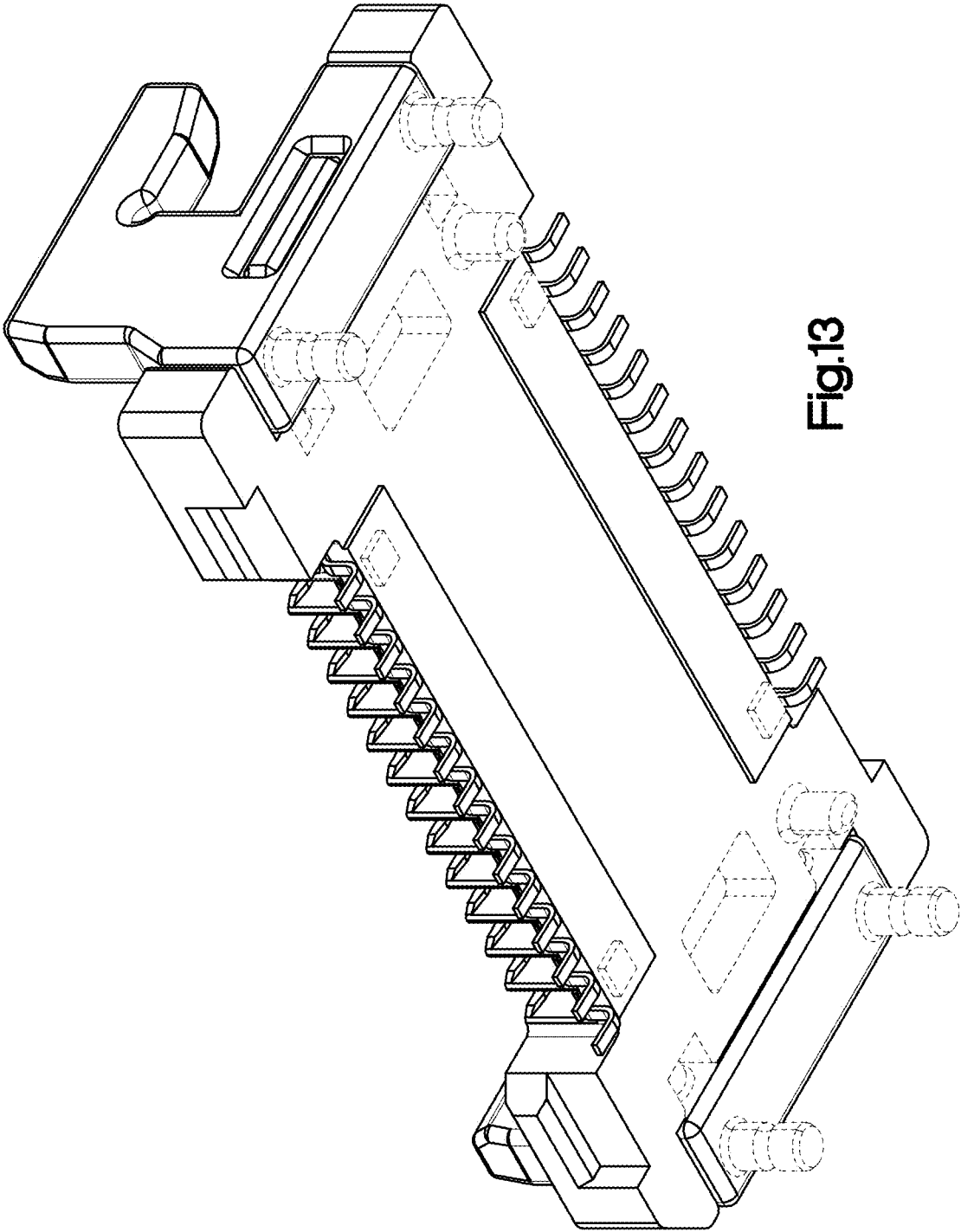

Fig.13

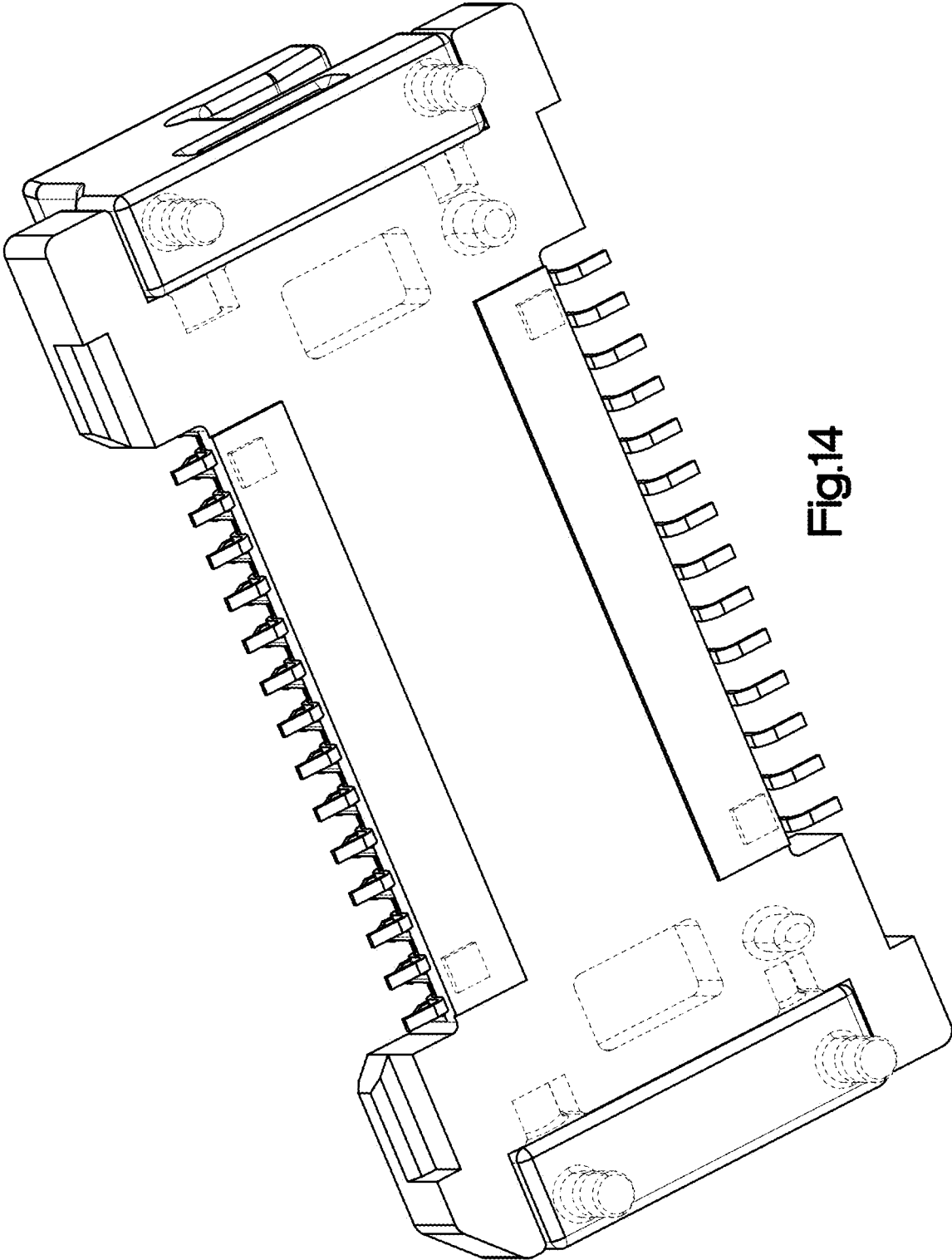

Fig.14

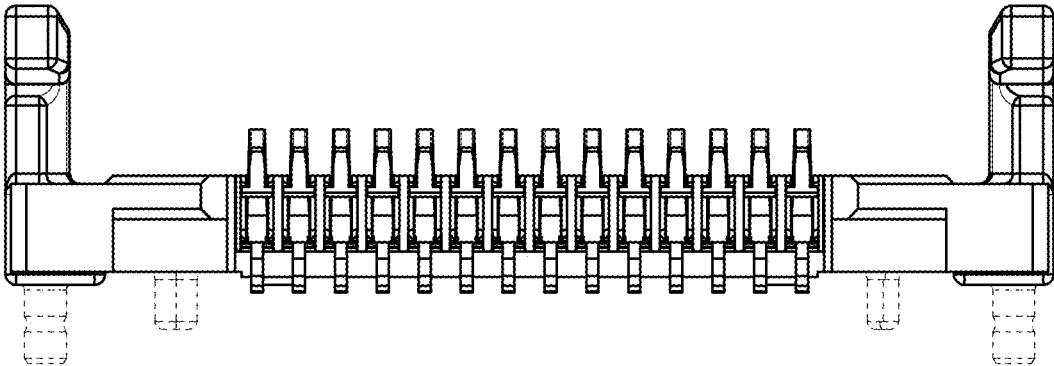

Fig.15

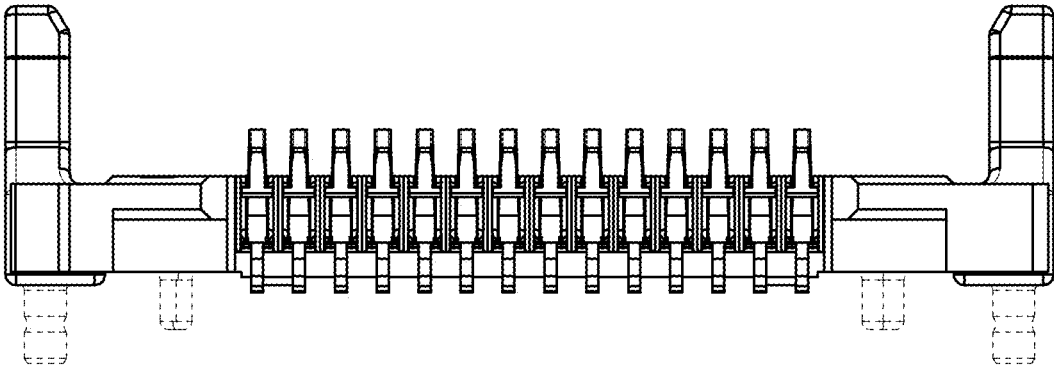

Fig.16

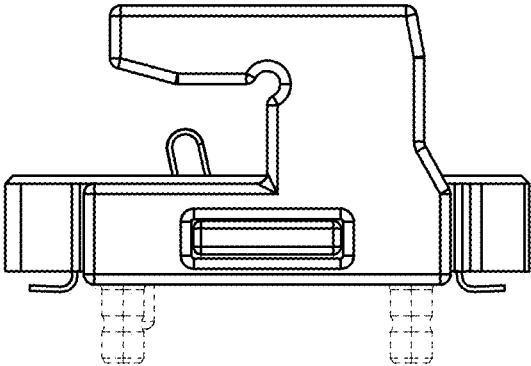

Fig.17

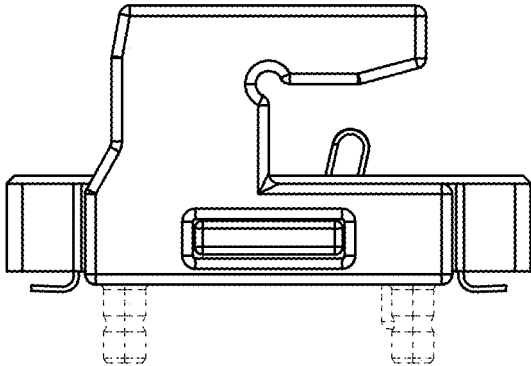

Fig.18

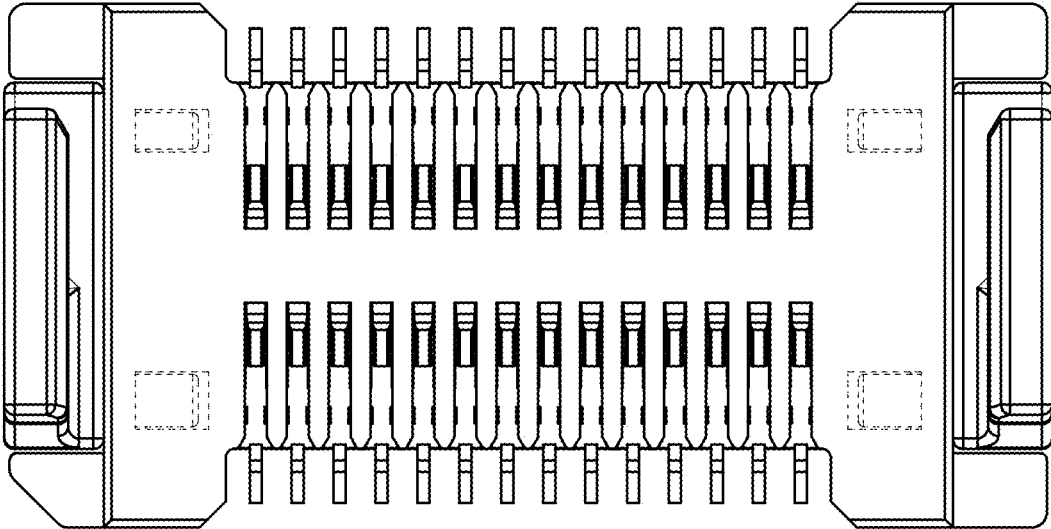

Fig.19

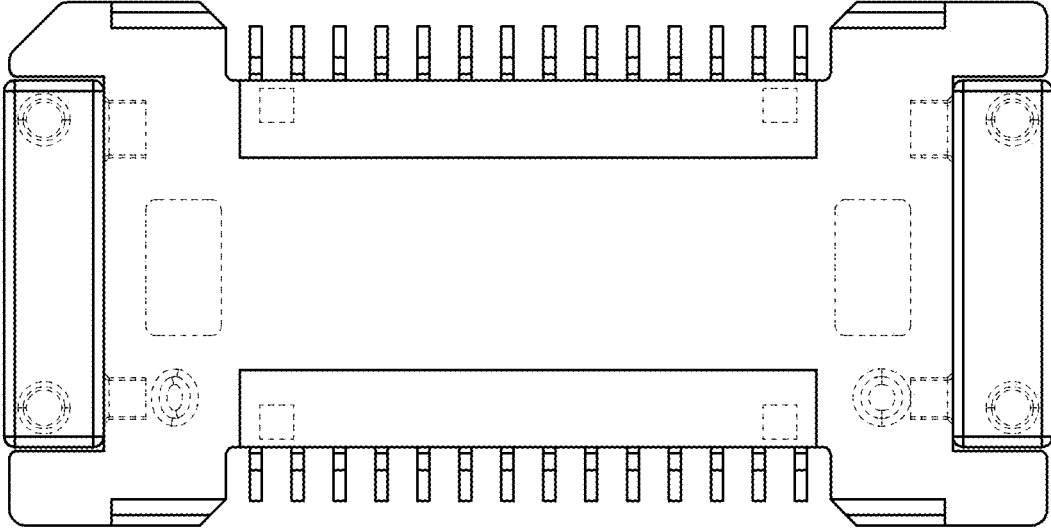

Fig.20