

(21) Application No 8806881.2
(22) Date of filing 23.03.1988

(71) Applicant
Benchmark Technologies Limited

(Incorporated in the United Kingdom)

79 Knightsbridge, London, SW1X 7KB,
United Kingdom

(72) Inventors
Neil Francis Trevett
Malcolm Eric Wilson

(74) Agent and/or Address for Service
Beresford & Co
2-5 Warwick Court, High Holborn, London,
WC1R 5DJ, United Kingdom

(51) INT CL⁴
H04N 5/262

(52) UK CL (Edition J)
H4F FD1B9 FD12M FD2A FD2B FGH
H4T TCHX T120 T124

(56) Documents cited
GB 2032217 A GB 1570773 A GB 1556812 A
GB 1556811 A GB 1318733 A

(58) Field of search
UK CL (Edition J) H4F FGG FGH FGJ FGS FGT,
H4T TCHA TCHX
INT CL⁴ H04N

(54) Analog controlled video mixer

(57) Two or more analog video signals are merged under control of a third analog video signal. A standard video output 154 from a digital to analog converter (DAC) is used as the control signal 156 for the merging of two or more other video signals RGB1, RGB2. This enables the video outputs of even highly diverse processing schemes to be easily merged. In its preferred embodiment, the system includes analog switching circuitry 140, 141, 142 which is used to mix the video outputs from two or more different systems. The system also includes circuitry (Fig 2) which converts the standard video output from the DAC into a large swing TTL signal which is used to control the analog switches.

The mixer may be used to merge video signals from graphics processors, video cameras or video recorders, and provides a simpler alternative to current digitally controlled mixers.

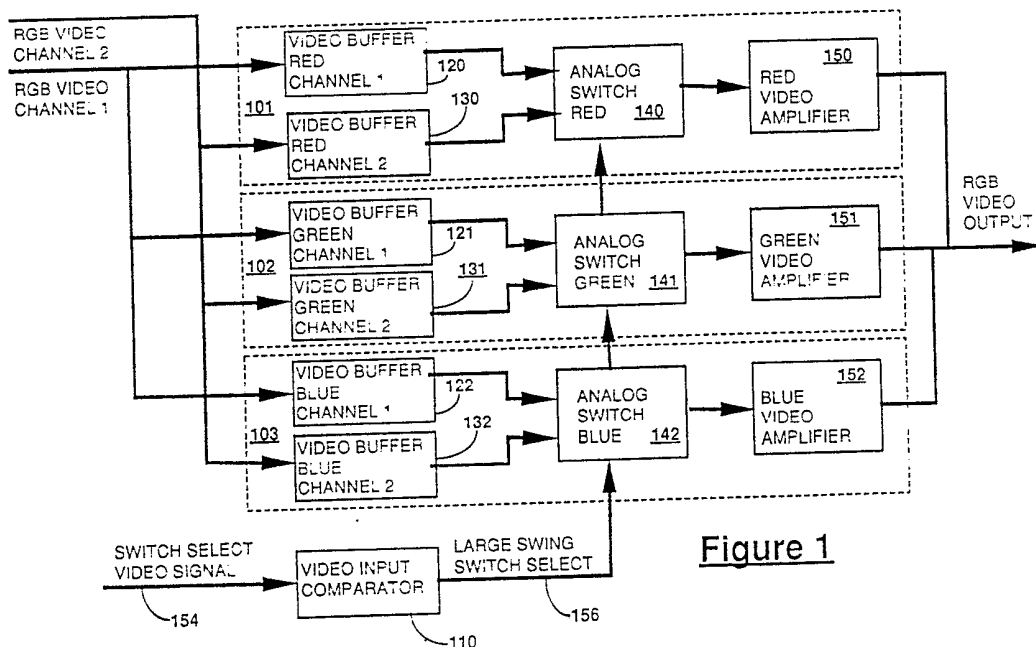

Figure 1

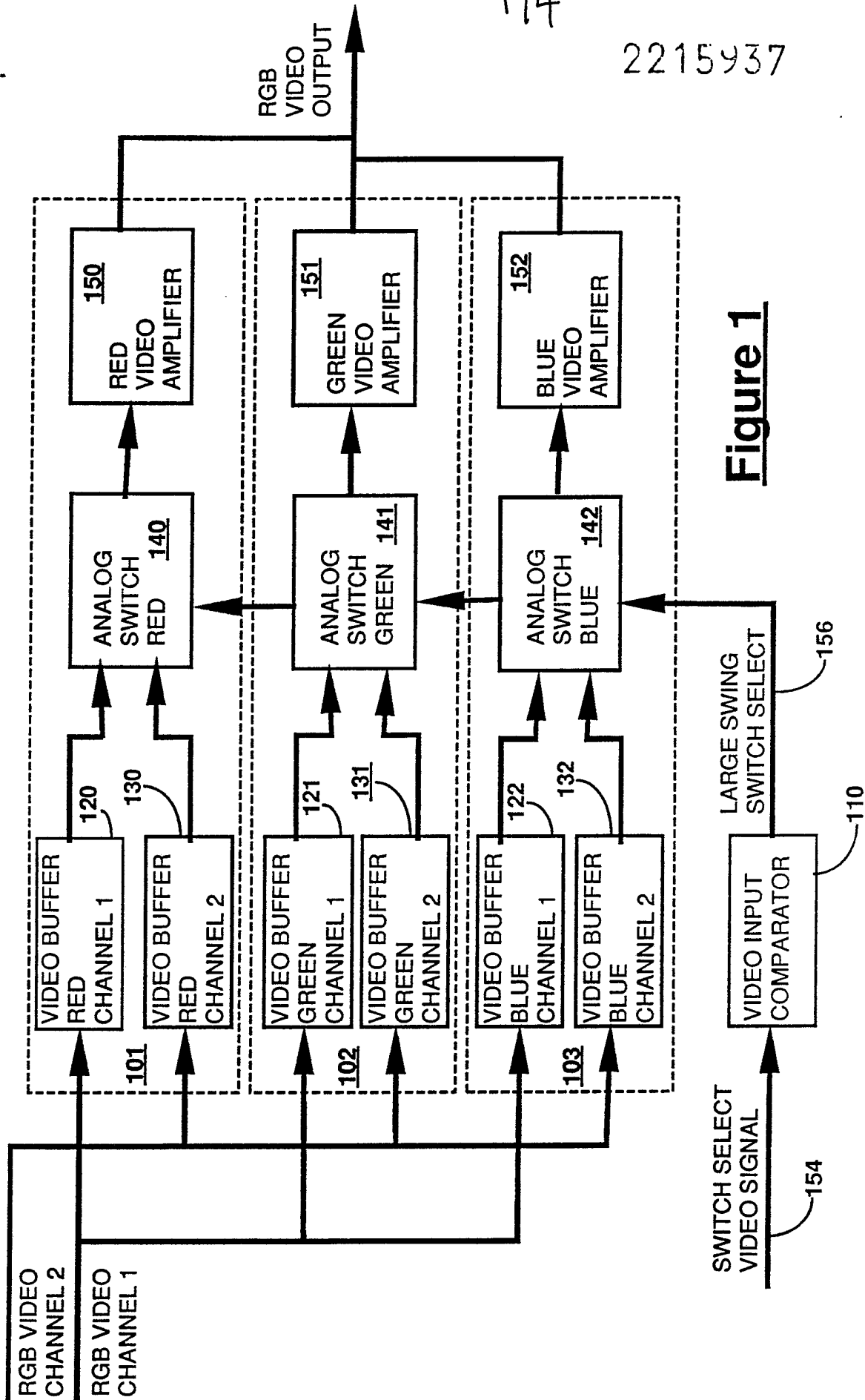

Figure 1

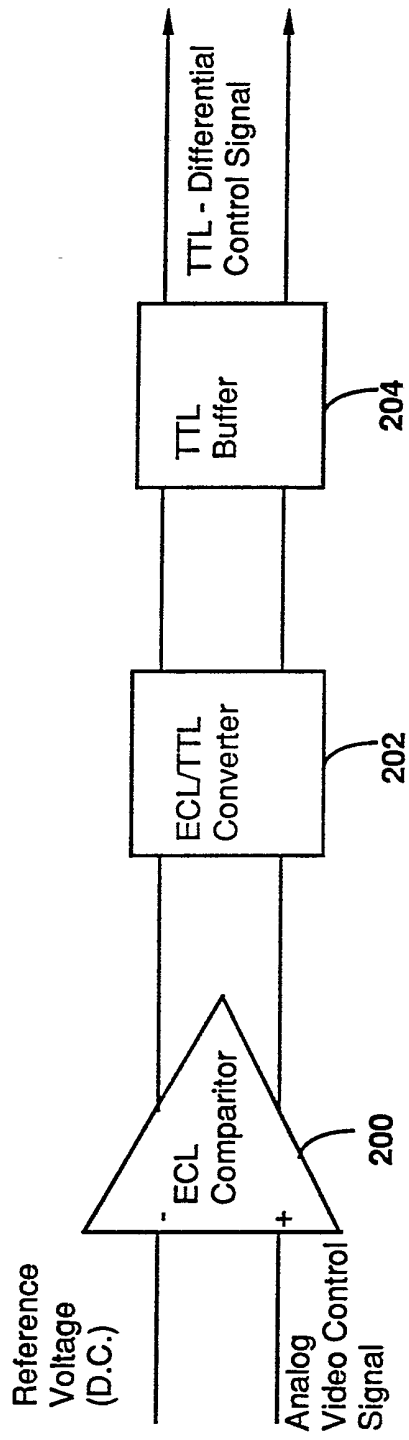

Figure 2

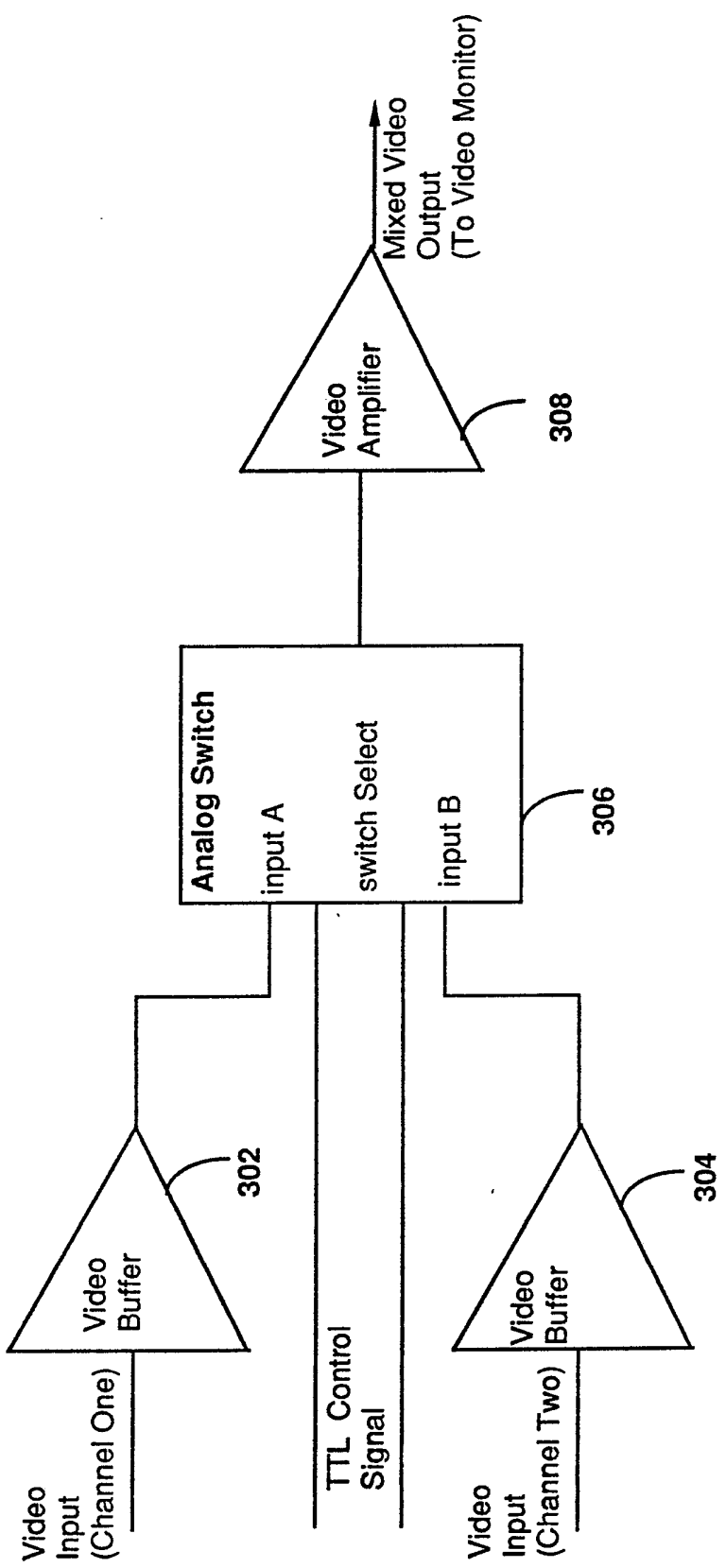

Figure 3

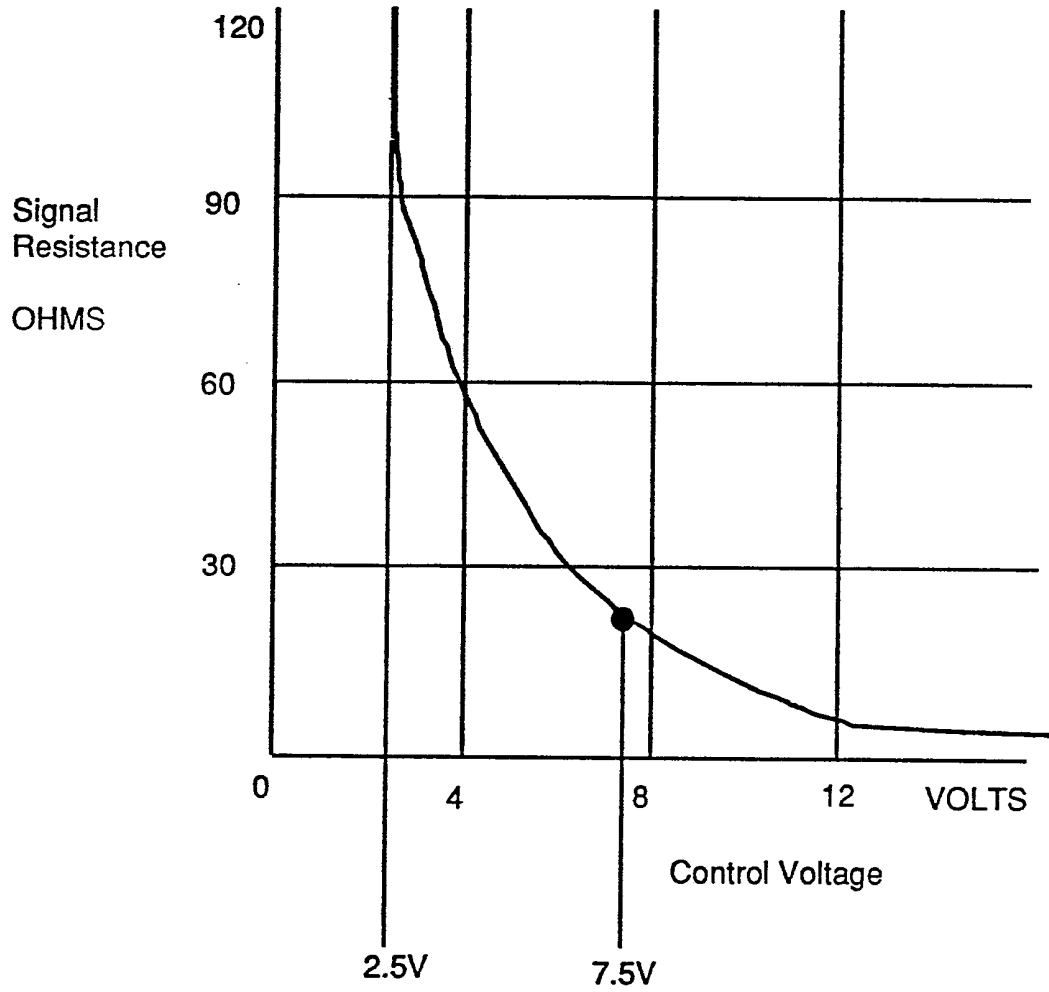

Figure 4

2215937

1

ANALOG CONTROLLED MIXER

I. BACKGROUND OF THE INVENTION

a. Field of the Invention

This invention relates to the field of graphics and
5 image processing.

b. Background of the invention

In the field of imaging and graphics it is often
10 necessary or desirable to be able to mix two or more video
signals for display on a video monitor. For example, a
window containing a video image from one graphics
processor may be inserted onto the video display of another
graphics processor, or any other video source such as a
15 camera output or video recording device. Another
application would be the creation of video overlays where
the video output information from one graphics processor is
mixed with the output of a second video source such that
certain colours on the first video output are treated as being
20 transparent, i.e. allowing the second source to be visible.

One conventional method of mixing two video signals
is by digitally combining the output signals before they are
converted into an analog video signal. In order to mix the
25 video outputs from separate systems, the system's
processors are synchronized and connected to a common

digital pixel data bus. The selection of which video signal to enable onto the pixel bus at any given position on the video display is made by a digital output select control signal. This signal could be produced by a window signal generating circuit or as some function of the image stored in one of the video output generators (for overlays) .

The problems with conventional digitally controlled techniques are several fold. First, the hardware required to perform the mixing at the level where the video information is still in its digital form is relatively cumbersome and complex. All of the systems must either be using a commonly structured internal pixel data format or communicate via specially designed interfaces. Also, digital switching techniques are generally slow (compared to the analog video signals) and may degrade system performance unless functioning with a great degree of parallelism (which increases circuit complexity).

II. SUMMARY OF THE INVENTION

The invention comprises a system and method for merging two or more analog video signals under control of a third analog video signal. The inventors have discovered that a standard video output from a processor's video signal digital to analog converter can be used to as the control signal for the merging of two or more other video signals.

10 In its preferred embodiment, the system includes analog switching circuitry which is used to mix the video outputs from two or more different systems. Advantageously, the system also includes circuitry which converts the standard video output from a third processor
15 into a large swing TTL signal which is used to control the analog switch.

The present system and method offer tremendous advantageous over conventional video mixing techniques.
20 First, video signal output standards are well defined. As long as two or more systems are using the same standard, their video signals can be mixed using a video signal from another system using the same standard.

25 A further advantage is that aside from the mixer itself, no extra hardware is neccerary to accomplish the mixing no

matter how the pixel data is formatted or handled by each video source internally. Using the present system and method, video signals from two vastly different systems can be easily and inexpensively merged.

5

Also, the video signals are available virtually for free. All video processors have an analog video output by their very definition. Many video processors have more than one video DAC available as a secondary output as well. The present system and method can be easily employed because any given analog video output, from any video DAC, on any system, can be used as a control signal in the merging of the remaining video outputs.

15

Further, video signals are fast. In digitally controlled switching, the digital control signal must keep up with the video output in order for the video signals to be properly mixed. In the present system and method, where one video signal is used to control the mixing of other video signals of the same standard, speed and timing are not a factor. As long as the processors are being driven by a common external clock, then speed and synchronization naturally take care of themselves.

20

III. BRIEF DESCRIPTION OF THE DRAWINGS

The invention is better understood by reference to the following drawings:

5

Figure 1 is a general block diagram of the present system, showing the merging of two separate three channel video outputs under control of a separate analog video switching signal.

10

Figure 2 is a more detailed block diagram showing the video input comparator block of Figure 1.

Figure 3 is a more detailed block diagram showing the video buffer, analog switch and video amplifier blocks of Figure 1.

15

Figure 4 is a diagram showing the general curve of the transfer characteristic of the analog switch of figure 1.

20

IV. DETAILED DESCRIPTION OF THE PREFERRED EMBODIMENTS.

Referring to Figure 1. The preferred embodiment of the present system and method includes three 2-1 analog mixers 101, 102, 103 the mixing being controlled by a video input comparator 110. Each analog mixer comprises an input buffer for channel 1 120, 121, 122 and an input buffer for channel 2 130, 131, 132, an analog switch 140, 141, 142 and an output video amplifier 150, 151, 152.

The input channel buffers 120, 130, 121, 131, 122, 132 are designed using a unity gain buffer device with a bandwidth great enough to not visibly degrade the video signal, which in a high resolution display can have a pixel clock rate of 109 Mhz. The presently preferred unity gain buffer device is an EL2005CG available from Elantec of Milpitas, California, U.S.A..

The analog switches 140,141,142 have a bandwidth great enough to allow no visible degradation of the video signal and must also allow the transmission of the signal to be enabled and disabled at high speed. The speed should preferably be less than the time for one output pixel (at 109 Mhz this is approximately 9.2 nanoseconds). The analog

switch used in the preferred embodiment is an SD5000N produced by Siliconix of Santa Clara, California, U.S.A..

5 The video amplifiers 150, 151, 152 must also degrade the display as little as possible. The function of the amplifier is the return the voltage levels to those required for the video standard being used (in this embodiment the video standard is RS-343A), and to buffer the output to the correct impedance value for the video standard (typically 75
10 ohms). The preferred embodiment of the video amplifiers uses an EL2022G produced by Elantec of Milpitas, California, U.S.A..

The video input comparator 110 must convert the
15 switch select video signal 154 to a large swing switch select signal 156. This is necessary to ensure that the analogue switch control input fully enables and disables the video paths. Figure shows the approximate transfer function for the switch type SD5000N.

20

The switch signal produced by the preferred embodiment has an 'off' level of 2.5 volts and an 'on' level of 7.5 volts. These levels allow for the video paths to be fully enabled and disabled with a margin to allow for any noise in
25 the circuitry. The preferred embodiment of the present system and method uses three devices to produce this large

swing signal; an ECL comparator 200 type VTC002 produced
by VTC Incorporated of Bloomington, Minnesota, USA, an
ECL to TTL convertor 202, type MC10H125P produced by
Motorola, U.S.A. and a TTL buffer 204, type V74FCT245
5 produced by VTC Incorporated.

An analog video control signal (which is a standard
video signal just as displayed signals) enters this series of
circuits at the input of the ECL comparator 200. As the
10 video control signal goes above and below the D.C. reference
voltage inputs, the comparators output will switch between
ECL levels. These devices 200, 202, 204 are run from a
power supply which is level shifted by 2.5 volts from that
used by the video display circuitry 302, 304, 306, 308. This
15 produces a voltage swing of 2.5 volts to 7.5 volts on the
control input of the analog switches relative to the analog
ground as the TTL buffer is producing standard TTL levels
(0 volts to 5 volts) relative to its ground level.

20 The reference voltage to the comparator is set so that
the comparator will switch at 0.375 volts. This allows a
standard video signal to switch the comparator with a
margin for noise. The switch select video signal would
normally be configured to only have full white and full black
25 signal levels to ensure good noise margins in the comparator
circuitry. These levels would normally be produced by

manipulating the video output palettes on the output producing the control signal.

In this preferred embodiment, the devices in the video input comparator path introduce a fixed delay between the large swing switch signal and those from channels 1 and 2. As all video sources are synchronised it is necessary to allow for this delay in some way. In the preferred embodiment the video cables for the two channels are made longer than the cable used for switch select video signal, the length being chosen to give a delay equal to that introduced by the video input comparator.

All the circuitry contained in the analog mixer is running at great speed (up to, for example, about 109 Mhz). Those with knowledge of the art will realise the care which must be taken in circuit layout to ensure to correct operation of such an apparatus.

The operation of the system and method will now be described by reference to Figures 2 and 3. A video signal from a first processor (not shown) will arrive at the input to a first video buffer 302, Another video signal from a second processor will arrive at the input of the second video buffer 404. The video buffers will perform current buffering and transmit the signals to the input A and input B lines of the

analog switch 306. A large swing TTL control signal (generated by a third processors video signal) will arrive at the switch select inputs synchronous with the two video signals and will cause the analog switch 306 to fully select
5 either input A and input B. The TTL signal is synchronous with the two video signals because all of the processor video output clocks are either tied or locked together.

Beacause all three signals are synchronous, the video
10 signal from the third processor will cause a pixel or series of pixels from the selected processor to be displayed. The video amplifier 308, takes the video signal and brings it back to correct levels for the chosen video standard.

15 Advantageously, all of the video signals (the two video data signals and the video control signal) can be taken from any processors standard video output (e.g. from a ramdac).

The following books are, in their entirety,
20 incorporated into this specification by reference: Siliconix INTEGRATED CIRCUITS DATA BOOK, (march 1985 edition), available from Siliconix Incorporated of 2201 Laurelwood Road, Santa Clara, California; elantec 1987 DATA BOOK, available from elantec, 1996 Tarob Court, Milpitas,
25 California. Each of these books in incorportated into this application by reference as if set forthin full below.

What is claimed is:

1. A method for merging two or more analog video signals carrying pixel data under control of a third analog video signal comprising the steps of:

5 Selecting between the pixel data carried in any one of the at least two analog video signals at a given time responsive to the characteristics of another analog video signal;

10

2. The method of claim 1 wherein the pixel data carried in any one of the at least two analog video signals at a given time is selected by the operating of an analog switch responsive to the characteristics of the other analog video
- 15 signal;

3. The method of claim 2 wherein all of the analog video signals are of the same informational interchange characteristic.

20

4. The method of claim 2 wherein all of the analog video signals are any of RS-343A and RS170 standards.

5. A video signal mixer comprising;
- 25 an analog switch having a first input for receiving a first analog video signal and a second input for receiving a

second analog video signal and a third input for receiving a switch select signal;

means for providing a first analog video signal to the first input of the analog switch;

5 means for providing a second analog video signal to the second input of the analog switch;

means for providing a switching signal at the third input of the analog video switch;

means for operating the switching signal responsive to
10 a third analog video signal.

6. The video signal mixer of claim 5 wherein the means for operating the switching signal comprises a comparator.

15 7. The video signal mixer of claim 6 wherein the means for providing the first and second analog video signals each comprise a buffer.

8. The video signal mixer of claim 7 wherein the
20 comparator and the analog switch are operated at different reference voltages;

9. The video signal mixer of claim 8 wherein the means for providing the first and second analog video signals each
25 further comprise a video processor having at least one digital to analog converter.

10. The video signal mixer of claim 9 wherein the video processors share a common video data clock.

5