



(19) **United States**

(12) **Patent Application Publication**

**Kim et al.**

(10) **Pub. No.: US 2013/0248622 A1**

(43) **Pub. Date: Sep. 26, 2013**

(54) **DRIP LINE AND EMITTER AND METHODS RELATING TO SAME**

(52) **U.S. Cl.**  
USPC ..... 239/542; 264/154

(76) Inventors: **Jae Yung Kim**, Los Angeles, CA (US);  
**Mark Richard Edris**, Glendora, CA (US);  
**Mark M. Ensworth**, Orange, CA (US);  
**Michael Leo Donoghue**, Tucson, AZ (US);  
**Berj Zakarian**, Redlands, CA (US)

(57) **ABSTRACT**

An irrigation emitter and drip line, and methods relating to same, are provided for reducing the flow and pressure of fluid via an emitter or plurality of emitters defined by two concentric tubes. In one form, the first tube defines an emitter inlet and connected pressure-reducing flow channel and the second tube is extruded over the first tube to enclose the emitter inlet and flow channel and defines an outlet connected to an end of the flow channel opposite the inlet to create an emitter for converting fluid flowing at a high flow rate in the lumen and at the first end of the inlet to a fluid with a low flow rate at the outlet of the emitter. In another form, a drip line is provided having a plurality of such emitters. Various other forms and methods relating to the emitter and drip line are also disclosed.

(21) Appl. No.: **13/430,308**

(22) Filed: **Mar. 26, 2012**

**Publication Classification**

(51) **Int. Cl.**  
**B05B 15/00** (2006.01)  
**B29D 23/00** (2006.01)

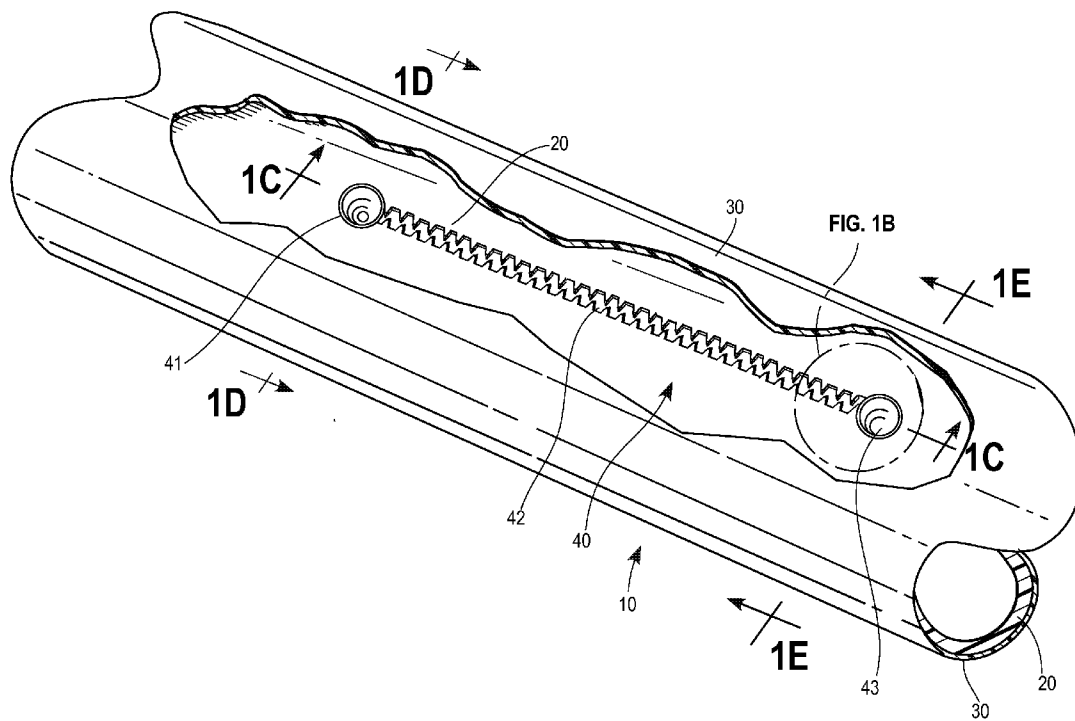

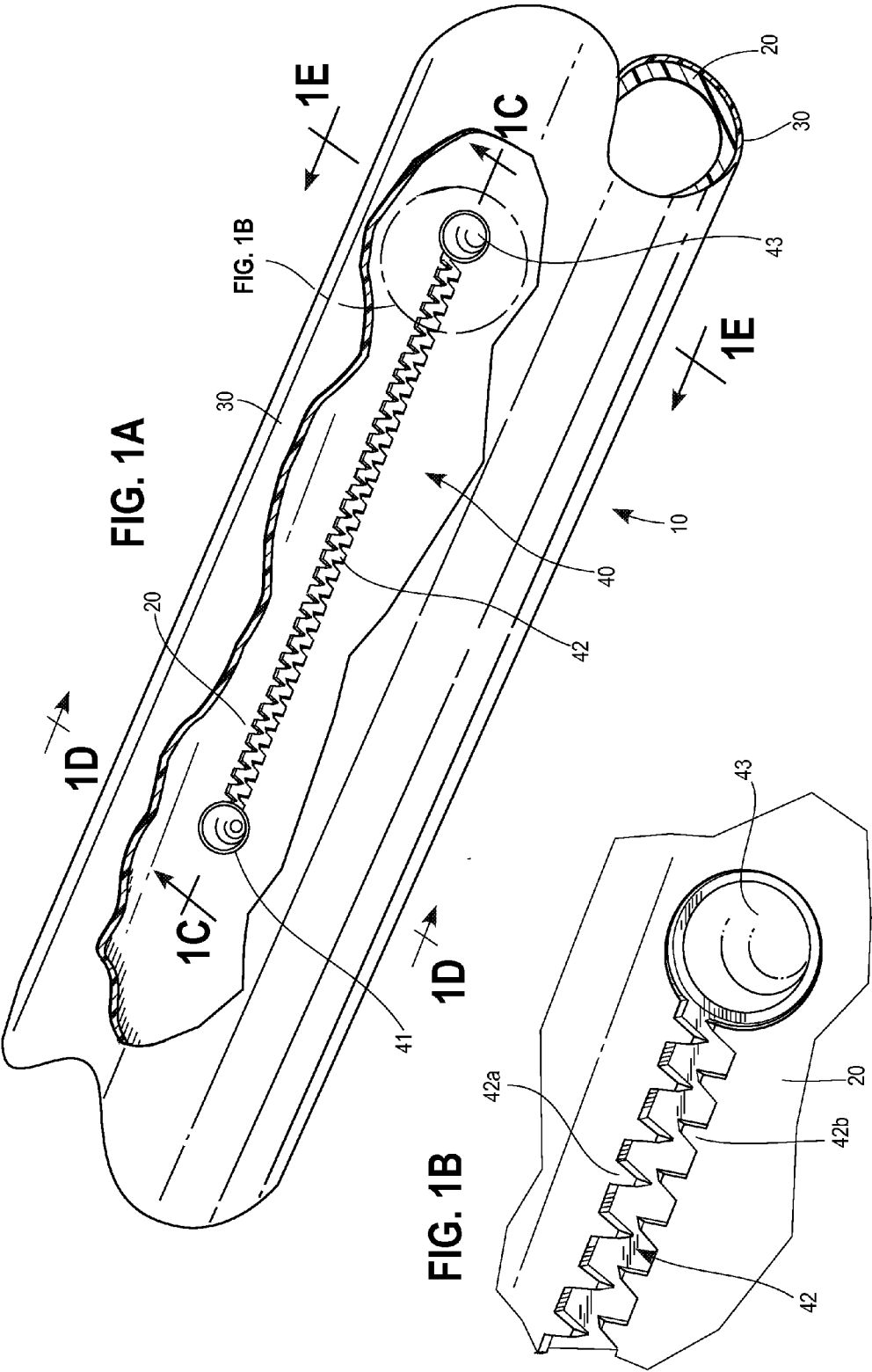

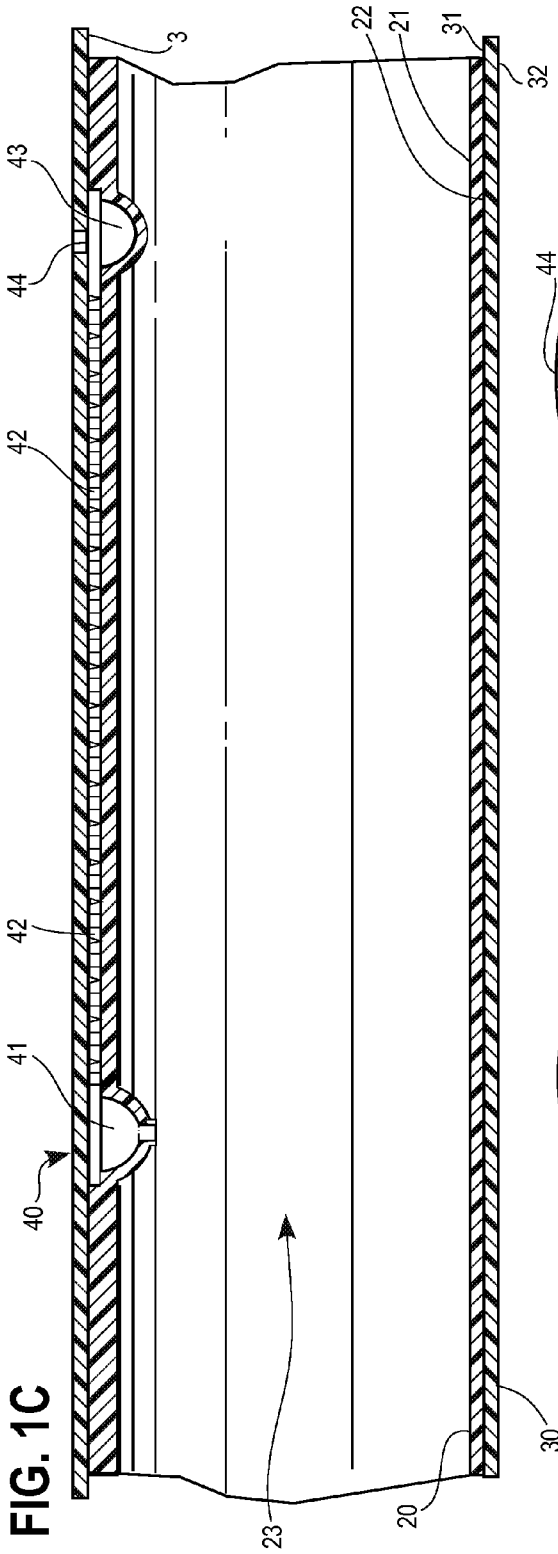

FIG. 1C

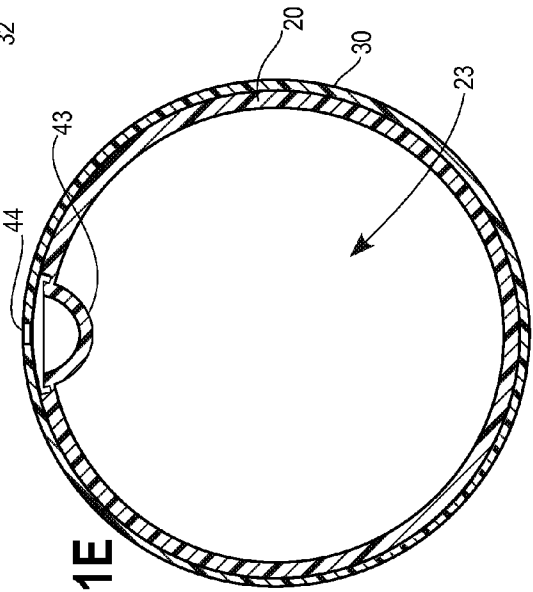

FIG. 1E

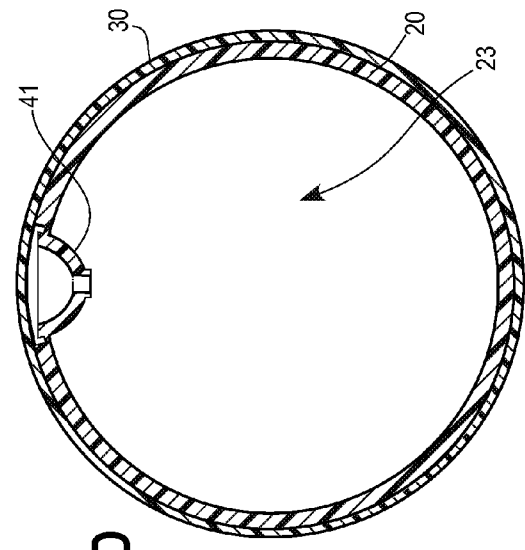
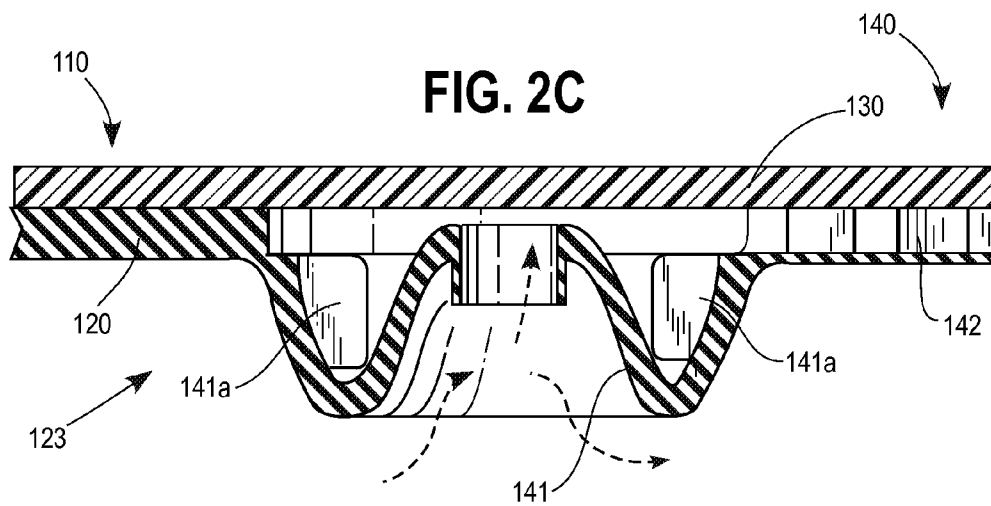
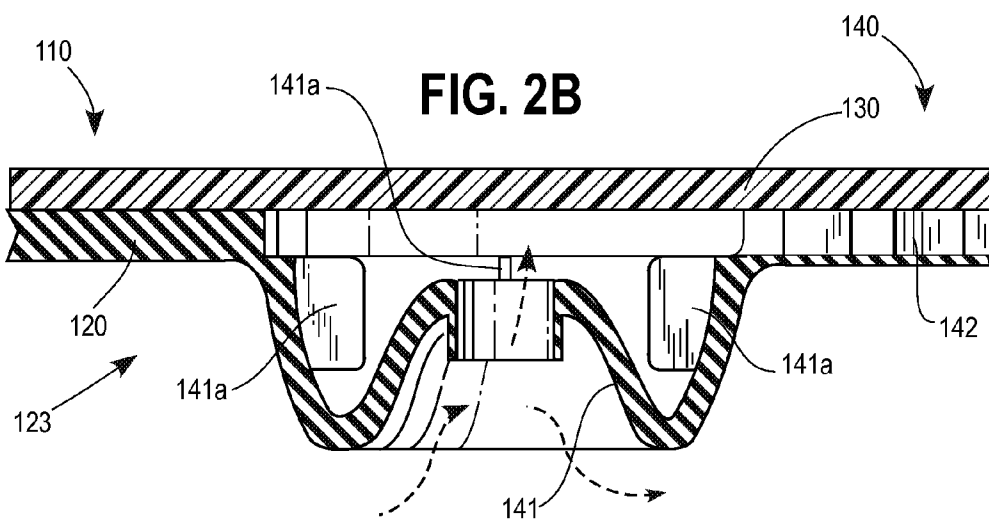
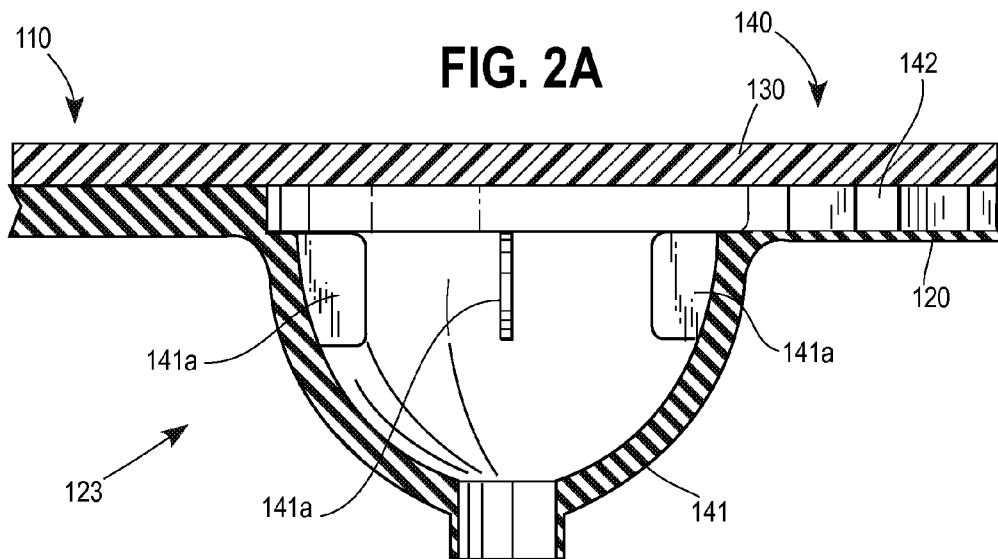

FIG. 1D



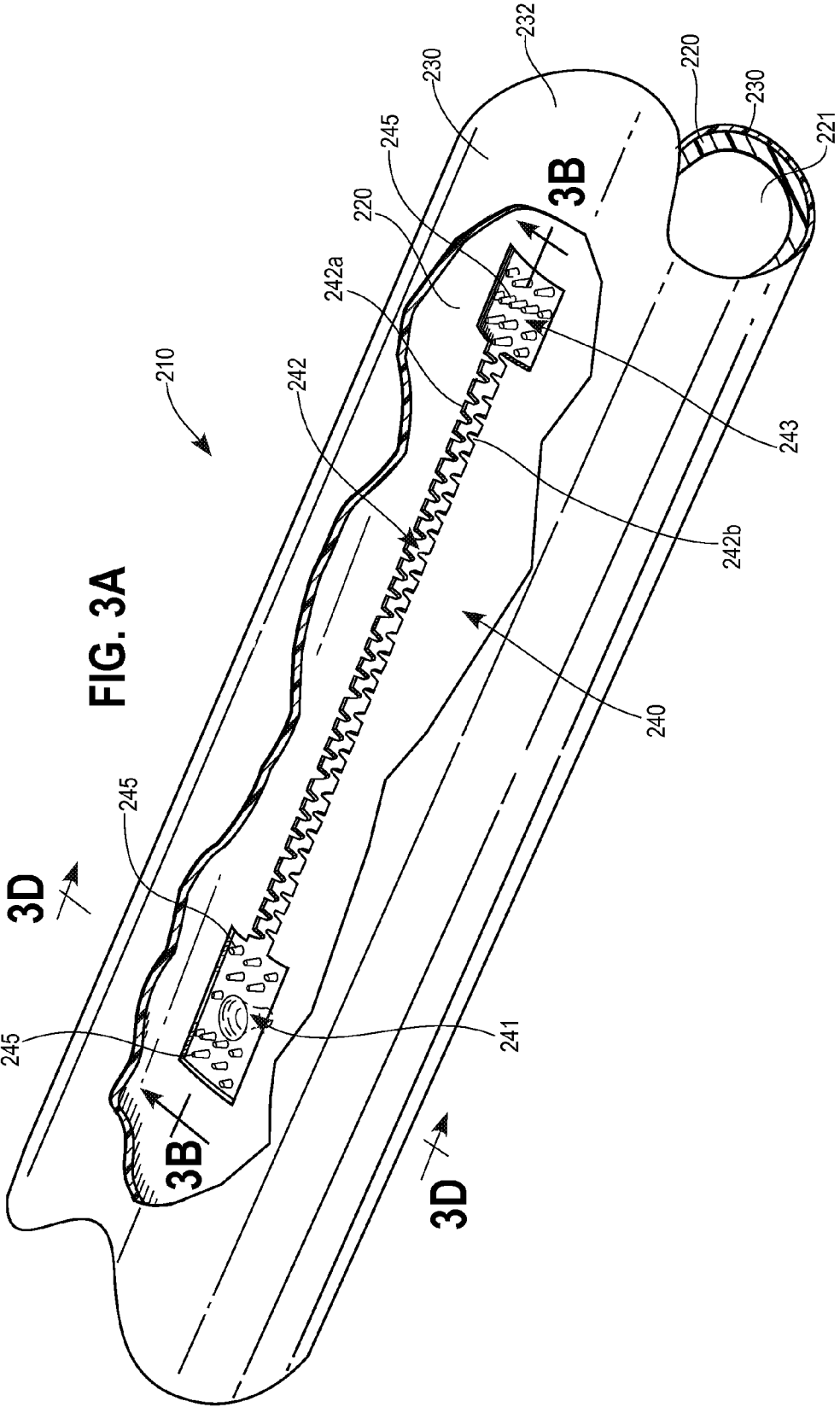
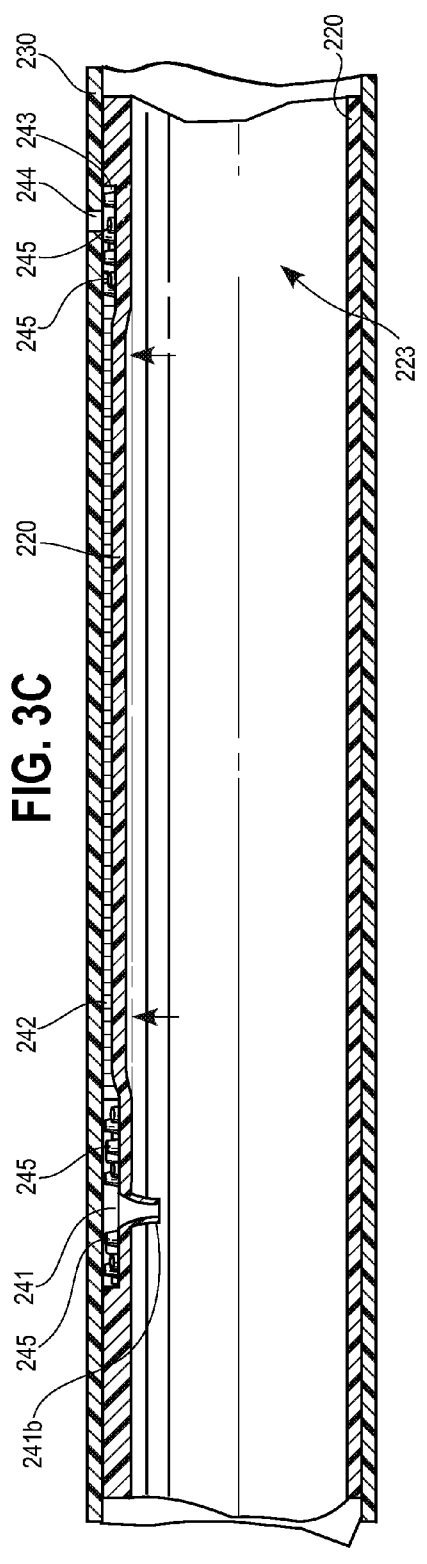
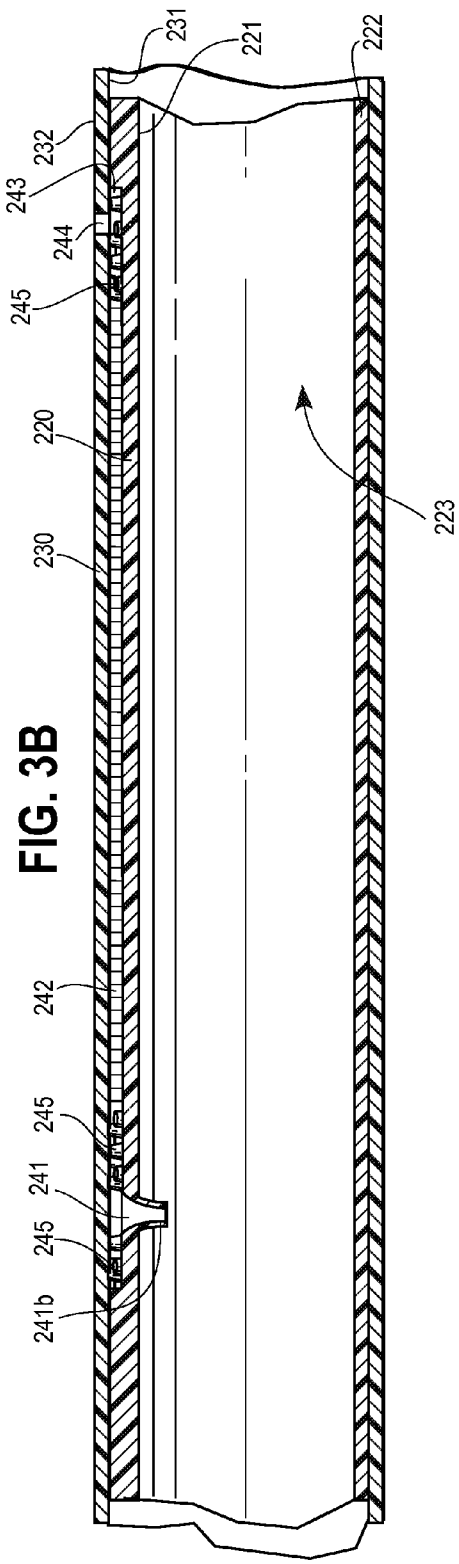
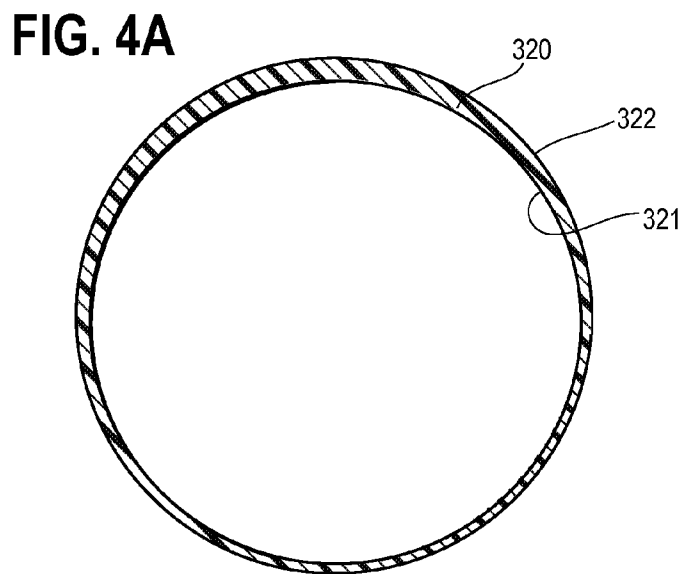
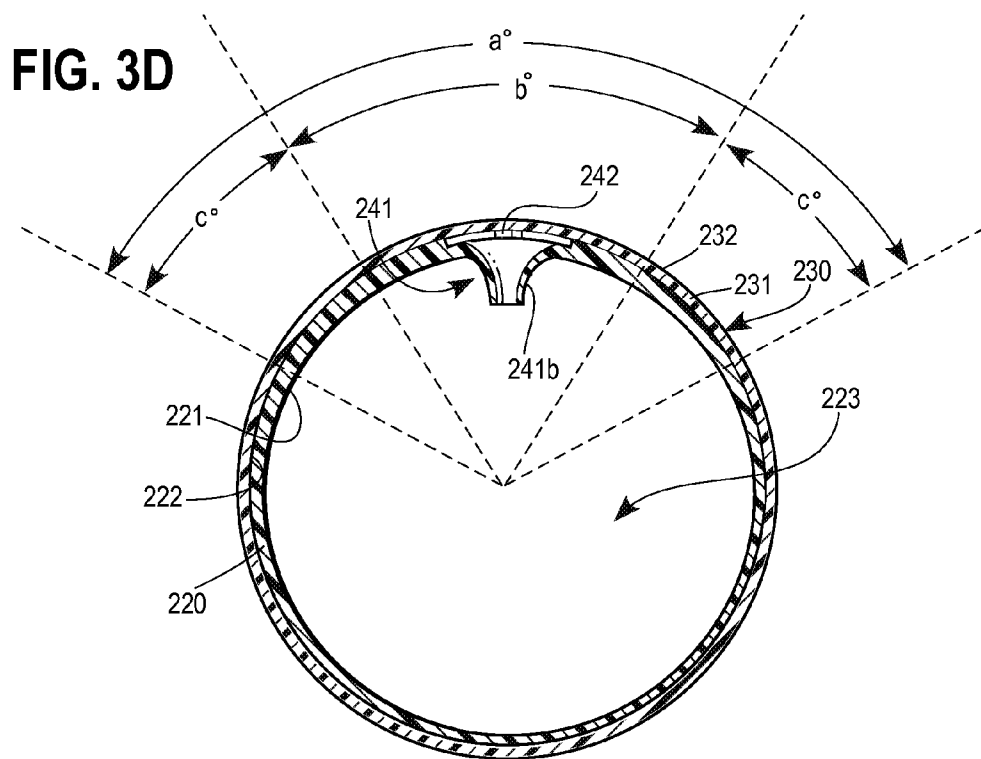
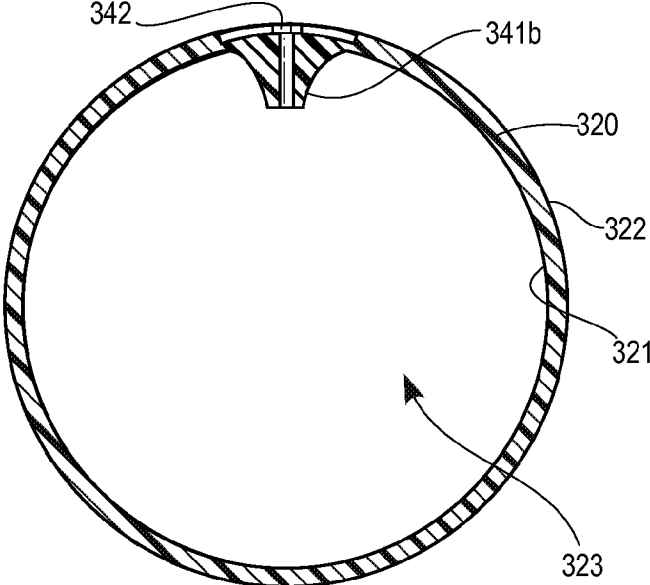

FIG. 3A

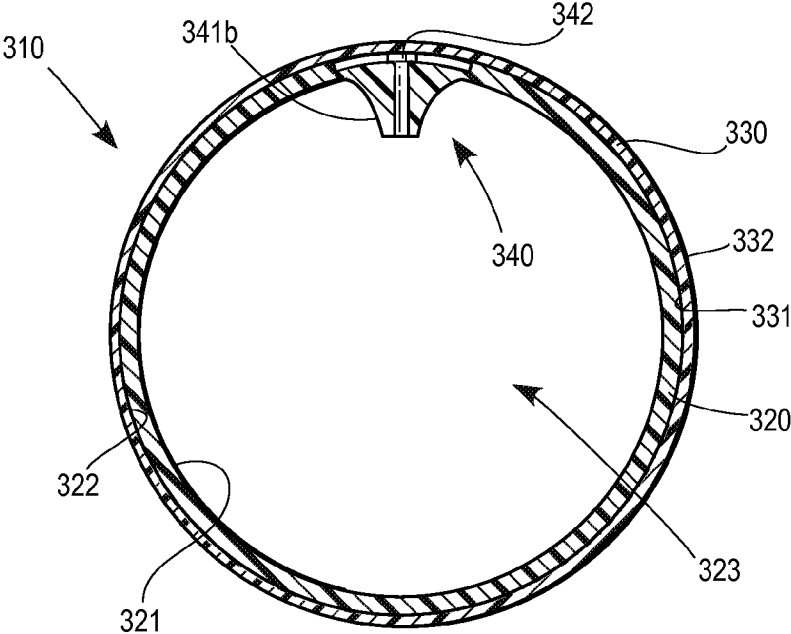



**FIG. 4B**

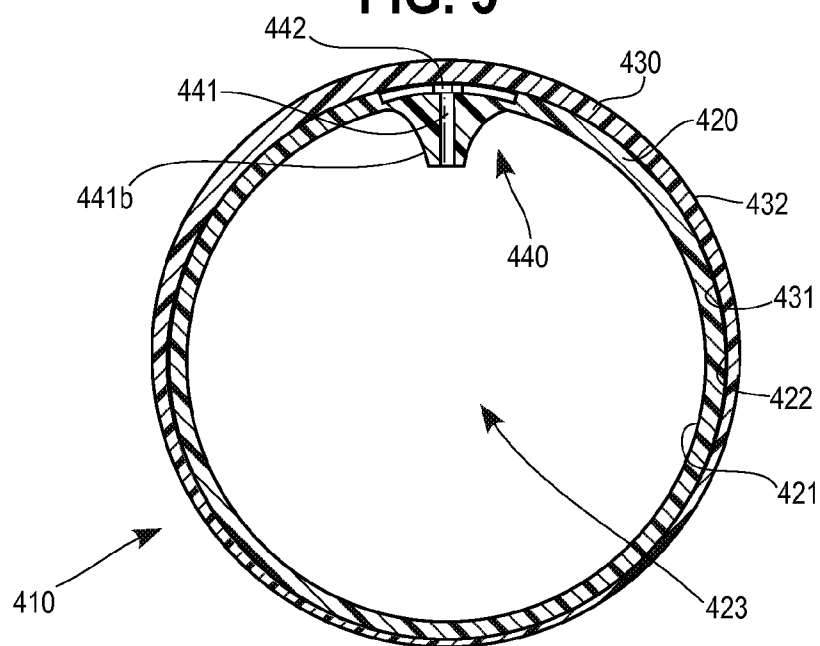

**FIG. 4C**

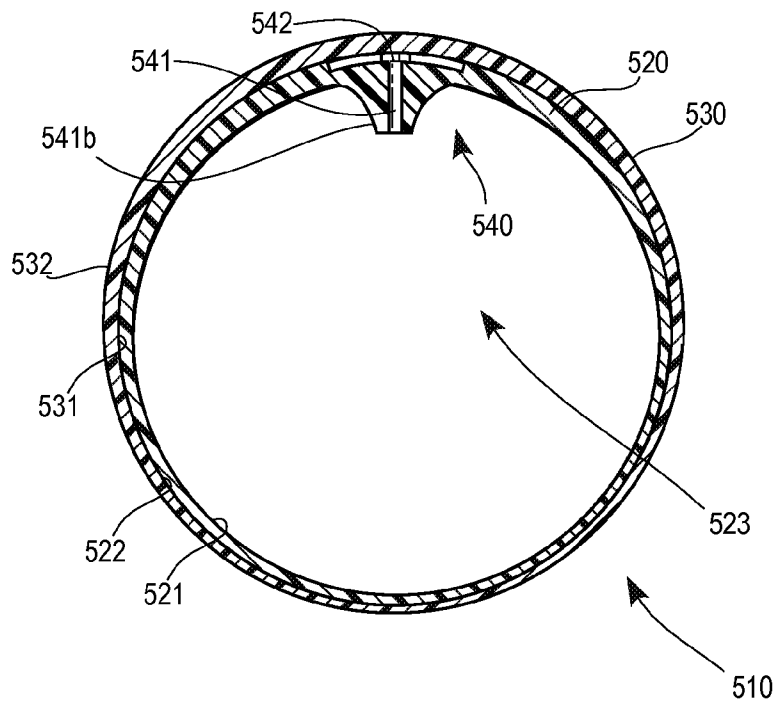



**FIG. 5**



**FIG. 6**



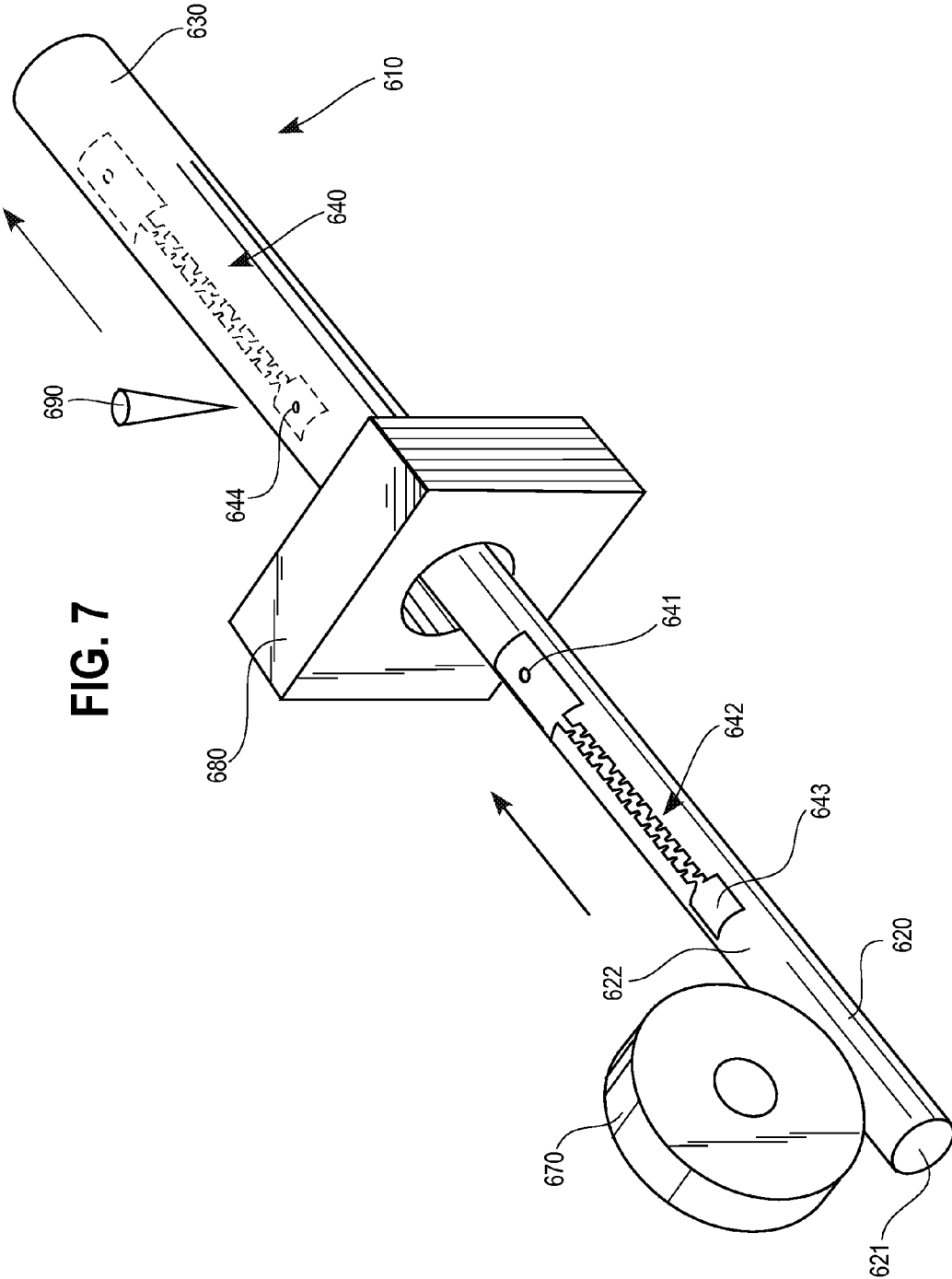
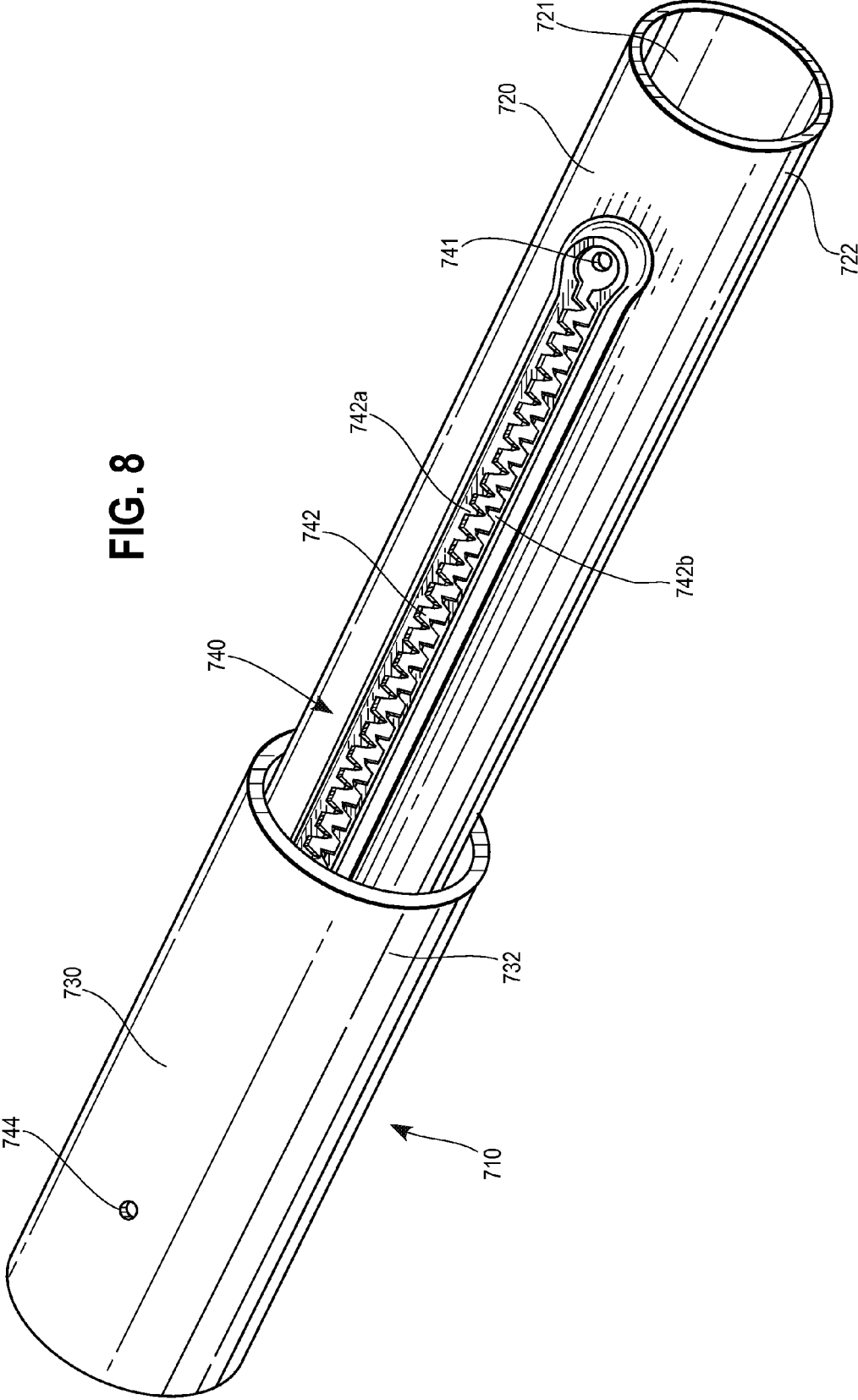

FIG. 7

FIG. 8



## DRIP LINE AND EMITTER AND METHODS RELATING TO SAME

### FIELD

[0001] The present invention relates to irrigation drip lines and emitters, and more particularly, to irrigation drip lines with multiple drip emitters forming an irrigation assembly or system.

### BACKGROUND

[0002] Irrigation drip emitters are commonly used in irrigation systems to convert fluid flowing through a supply tube or drip line at a relatively high flow rate to a relatively low flow rate at the outlet of each emitter. Such emitters are typically used in landscaping (both residential and commercial) to water and/or treat (e.g., fertilize) trees, shrubs, flowers, grass and other vegetation, and in agricultural applications to water and/or treat crops. Typically, multiple drip emitters are positioned on the inside or outside of a water supply line or tube at predetermined intervals to distribute water and/or other fluids at precise points to surrounding land and vegetation. The emitter normally includes a pressure reducing passageway, such as a zigzag labyrinth or passage, which reduces high pressure fluid entering the drip emitter into relatively low pressure fluid exiting the drip emitter. Generally, such drip emitters are formed in one of three common manners: (1) separate structures connected to a supply tube either internally (i.e., in-line emitters) or externally (i.e., on-line emitters or branch emitters); (2) drip strips or tape either connected to an inner surface of a supply tube or in-between ends of a material to form a generally round supply tube or conduit; and (3) stamped into a surface of a material that is then folded over upon itself or that overlaps itself to form a drip line with an enclosed emitter.

[0003] With respect to the first type of common drip emitter, the emitter is constructed of a separate housing that is attached to the drip line. The housing is normally a multi-piece structure that when assembled defines the pressure reducing flow path that the fluid travels through to reduce its pressure. Some examples of in-line emitters that are bonded to an inner surface of the supply line or tube are illustrated in U.S. Pat. No. 7,648,085 issued Jan. 19, 2010 and U.S. Patent Application Publication No. 2010/0282873, published Nov. 11, 2010, and some examples of on-line emitters which are connected to an exterior surface of the supply line or tube (usually by way of puncture via a barbed end) are illustrated in U.S. Pat. No. 5,820,029 issued Oct. 13, 1998. Some advantages to in-line emitters are that the emitter units are less susceptible to being knocked loose from the fluid carrying conduit and the conduit can be buried underground if desired (i.e., subsurface emitters) which further makes it difficult for the emitter to be inadvertently damaged (e.g., by way of being hit or kicked by a person, hit by a lawnmower or trimmer, etc.).

[0004] With respect to the second type of emitter, (i.e., drip strips or tape), the emitter is typically formed at predetermined intervals along a long stretch of material which is either bonded to the inner surface of the supply line or connected between ends of a material to form a generally round conduit or supply line with the strip or tape running the longitudinal length of the conduit. Some examples of drip strips or tape type emitters are illustrated in U.S. Pat. No. 4,726,520 issued Feb. 23, 1988.

[0005] With respect to the third type of emitter, (i.e., folded or overlapping tube emitters), the emitter is typically formed by stamping a pressure reducing flow path on one surface of a tube making material at or near an end thereof which is then folded back over on itself or which is wrapped such that the opposite end of the tube making material overlaps the end with the stamped flow path to form an enclosed pressure-reducing passageway. Some examples of folded or overlapping tube emitters are illustrated in U.S. Pat. No. 4,726,520 issued Feb. 23, 1988, and International Patent Application Publication No. WO 00/01219 published Jan. 13, 2000.

[0006] In addition, many if not all of the above mentioned emitters can be manufactured with a pressure compensating mechanism that allows the emitters to adjust or compensate for fluctuations in the fluid pressure within the supply line. For example, some of the above emitters include separate elastomeric diaphragms which are positioned adjacent the pressure reducing passageway and help reduce the cross-section of the passageway when an increase in supply line fluid pressure occurs and increase the cross-section of the passageway when a decrease in the supply line fluid pressure occurs.

[0007] While each of these forms of emitters has its own advantage, they each require either multiple pieces to be assembled, aligned and carefully bonded to the supply line or intricate stamping and folding or overlapping to be performed in order to manufacture the emitter and ensure that the emitter operates as desired. Thus, these emitters often require more time and care to assemble which needlessly can slow down the production of the drip line and/or emitter and can increase the cost of the drip line and/or emitter as well. Thus, there is a need for a simpler emitter construction that can be manufactured faster and using fewer parts and without wasting as much time, energy and materials related to aligning and assembling multiple parts of the emitter and/or folding or overlapping materials.

[0008] In addition, some of the above-mentioned emitters introduce structures (sometimes even the entire emitter body) into the main lumen of the supply line or tube which can cause turbulence and result in later emitters or emitters further downstream not working as well or efficiently as earlier emitters or upstream emitters. For example, in some of the non-pressure compensated emitters the introduction of too much turbulence from emitter structures located upstream can reduce the pressure of the fluid further downstream and result in the downstream emitters trickling water at a different flow rate than upstream emitters. This is not normally desirable as in most applications it would be desirable that the emitters of the drip line saturate their respective surrounding area at a common flow rate rather than having one portion of the drip line saturate one area more than another portion of the drip line saturates another area.

[0009] In other in-line emitters, large cylindrical structures are used which interfere with the flow of the fluid traveling through the drip line or tube and introduce more turbulence to the fluid or system due to the fact they cover and extend inward from the entire inner surface of the drip line or tube. The increased mass of the cylindrical unit and the fact it extends about the entire inner surface of the drip line or tube also increases the likelihood that the emitter will get clogged with grit or other particulates (which are more typically present at the wall portion of the tube or line than in the middle of the tube or line) and/or that the emitter itself will form a surface upon which grit or particulates can build-up on inside

the drip line and slow the flow of fluid through the drip line or reduce the efficiency of the fluid flowing therethrough. Thus, there is also a need to reduce the size of in-line emitters and improve the efficiency of the systems within which these items are mounted.

**[0010]** Thus, there is a need for a new drip line and/or emitter that does not introduce structures into the central or main lumen of the supply line or drip line, that does not introduce turbulence into the system and/or that does not provide a surface for grit to build-up on, all of which could affect the operation of the drip line or emitters and, particularly, negatively affect the operation of downstream emitters. Providing such an emitter with a pressure compensating feature would also be desirable.

**[0011]** As mentioned above, some emitters can be positioned within the supply line or drip line so that the supply line can be buried underground (i.e., subsurface applications). In addition to the advantages of in-line emitters, subsurface drip emitters provide numerous advantages over drip emitters located and installed above ground. First, they limit water loss due to runoff and evaporation and thereby provide significant savings in water consumption. Water may also be used more economically by directing it at precise locations of the root systems of plants or other desired subsurface locations.

**[0012]** Second, subsurface drip emitters provide convenience. They allow the user to irrigate the surrounding terrain at any time of day or night without restriction. For example, such emitters may be used to water park or school grounds at any desired time. Drip emitters located above ground, on the other hand, may be undesirable at parks and school grounds during daytime hours when children or other individuals are present.

**[0013]** Third, subsurface emitters are not easily vandalized, given their installation in a relatively inaccessible location, i.e., underground. Thus, use of such subsurface emitters results in reduced costs associated with replacing vandalized equipment and with monitoring for the occurrence of such vandalism. For instance, use of subsurface emitters may lessen the costs associated with maintenance of publicly accessible areas, such as parks, school grounds, and landscaping around commercial buildings and parking lots.

**[0014]** Fourth, the use of subsurface drip emitters can prevent the distribution of water to undesired terrain, such as roadways and walkways. More specifically, the use of subsurface drip emitters prevents undesirable "overspray." In contrast, above-ground emitters often generate overspray that disturbs vehicles and/or pedestrians. The above-identified advantages are only illustrative; other advantages exist in connection with the use of subsurface drip emitters.

**[0015]** Although some advantages of subsurface emitters are described above, it would be desirable to provide an improved drip emitter design that can be used in both subsurface and above ground applications that provides relatively constant fluid output from each of the emitters in the irrigation system without the problems associated with conventional emitters (e.g., negative effects of turbulence and grit build-up associated with emitters that project into the central or main lumen of the supply line, multi-part construction requiring alignment and assembly, or complex folding/overlapping, etc.).

**[0016]** Accordingly, it has been determined that the need exists for an improved emitter construction and/or drip line and methods relating to same which overcomes the aforemen-

tioned limitations and which further provides capabilities, features and functions, not available in current drip lines or emitters and methods.

#### BRIEF DESCRIPTION OF THE DRAWINGS

**[0017]** The above and other aspects, features and advantages of several embodiments of the present invention will be more apparent from the following more particular description thereof, presented in conjunction with the following drawings.

**[0018]** FIG. 1A is a perspective view of a drip line and emitter embodying features of the present invention, with an outer layer of the drip line cutaway so that the emitter is visible for purposes of discussion;

**[0019]** FIG. 1B is an enlarged view of the outlet and adjacent pressure-reducing flow channel of the emitter and drip line of FIG. 1A, illustrating a closer view of the baffle walls and teeth that make-up a portion of the pressure-reducing flow channel;

**[0020]** FIG. 1C is a cross-sectional view of the drip line and emitter of FIG. 1A taken along line 1C-1C, but illustrating the outer layer of the drip line that was cut out of FIG. 1A;

**[0021]** FIGS. 1D-E are cross-sectional views of the drip line and emitter of FIG. 1A taken along lines 1D-1D and 1E-1E, respectively, with FIG. 1D illustrating a cross-sectional view of the inlet-end of the emitter and FIG. 1E illustrating a cross-sectional view of the outlet-end of the emitter;

**[0022]** FIGS. 2A-C are cross-sectional views of an alternate inlet embodiment taken from the same perspective as the cross-sectional inlet view illustrated in FIG. 1A, with FIG. 2A illustrating the inlet opening subjected to low fluid pressure, FIG. 2B illustrating the inlet opening subjected to higher fluid pressure sufficient to cause the inlet dome to partially collapse on itself as a means for compensating for fluid pressure fluctuations in the supply line or drip line, and FIG. 2C illustrating the inlet opening subjected to even higher fluid pressure sufficient to cause the inlet dome to more fully collapse on itself (but not totally collapsing so that fluid can still flow through the emitter) as a means for compensating for fluid pressure fluctuations in the supply line or drip line;

**[0023]** FIG. 3A is a perspective view of an alternate drip line and emitter embodying features of the present invention, with an outer layer of the drip line cutaway so that the emitter is visible;

**[0024]** FIG. 3B is a cross-sectional view of the alternate drip line and emitter taken along lines 3B-3B in FIG. 3A and illustrating the floor of the pressure-reducing flow channel subject to low supply line fluid pressure;

**[0025]** FIG. 3C is a cross-section view of the alternate drip line and emitter of FIG. 3A taken along line 3C-3C in FIG. 3A and illustrating the floor of the pressure-reducing flow channel subject to a higher supply line fluid pressure sufficient to push the floor up into the flow channel thereby reducing the cross-sectional area of the flow channel to compensate for the increase in supply line fluid pressure;

**[0026]** FIG. 3D is a cross-sectional view of the alternate drip line and emitter of FIG. 3A taken along line 3D-3D and illustrating one form of an inlet capable of drawing fluid from a more central portion of the supply line and illustrating a concentric tube structure wherein the inner tube has an enlarged thickness in the portion of the tube where the emitter is stamped but a reduced thickness elsewhere and the outer tube has a uniform thickness;

**[0027]** FIGS. 4A-C illustrate cross-sectional views of an alternate drip line and emitter embodying features of the present invention taken from the same perspective of FIG. 3D and at various stages of manufacture of the drip line and emitter, with FIG. 4A illustrating the inner tube of a concentric tube structure pre-stamped, FIG. 4B illustrating the tube of FIG. 4A after the emitter is stamped in the tube and showing how the thickness of the tube may be designed so that after the emitter is stamped in the tube the inner tube has a generally uniform thickness, and FIG. 4C illustrating an outer tube extruded over the inner tube of uniform thickness and a thickness that is smaller than that of the inner tube thickness;

**[0028]** FIG. 5 illustrates a cross-sectional view of an alternate drip line and emitter embodying features of the present invention taken from the same perspective of FIGS. 3D and 4A-C, but illustrating an inner tube that has a generally constant thickness after the emitter is stamped therein and an outer tube that is thickened in the portion above the emitter but has reduced thickness elsewhere;

**[0029]** FIG. 6 illustrates a cross-sectional view of an alternate drip line and emitter embodying features of the present invention taken from the same perspective of FIGS. 3D, 4A-C and 5, but illustrating inner and outer tubes that are each thickened in the portion proximate the emitter and that have reduced thickness elsewhere;

**[0030]** FIG. 7 illustrates a perspective view of a process for manufacturing drip lines and emitters in accordance with the invention disclosed herein and showing an extruded inner tube being embossed with the pressure reducing flow channel and then an outer tube extruded over the inner tube to form an enclosed or sealed emitter with an outlet opening punched through the outer tube to complete the emitter; and

**[0031]** FIG. 8 illustrates a perspective view of an alternate drip line and emitter embodying features of the present invention in which the walls of the flow channel are stamped such that they extend out from the outer diameter of the first tube member to form a raised flow channel passage rather than having the flow channel stamped into the outer diameter of the first tube to form a recessed flow channel passage.

**[0032]** Corresponding reference characters indicate corresponding components throughout the several views of the drawings. Skilled artisans will appreciate that elements in the figures are illustrated for simplicity and clarity and have not necessarily been drawn to scale. For example, the dimensions of some of the elements in the figures may be exaggerated relative to other elements to help to improve understanding of various embodiments of the present invention. Also, common but well-understood elements that are useful or necessary in a commercially feasible embodiment are often not depicted in order to facilitate a less obstructed view of these various embodiments of the present invention.

#### DESCRIPTION OF THE PREFERRED EMBODIMENTS

**[0033]** As shown in FIGS. 1A-E, an irrigation drip line 10 is provided for distributing water from a fluid supply source via a plurality of emitters 40 so that some of the pressurized fluid from the fluid supply source can be trickled out from the emitters 40 at a low flow rate to surrounding landscape or vegetation. In a preferred form, the drip line 10 carries pressurized fluid throughout an irrigation system and preferably includes numerous emitters 40 spaced apart at predetermined intervals in the dip line 10 in order to allow the drip line 10 to

be placed above or below ground to water and/or treat grass, plants, shrubs, trees or other landscaping, or to water agricultural crops of various kinds.

**[0034]** In the form illustrated, the drip line 10 and emitter 40 are formed by two concentric tubes 20 and 30, respectively. The first tube or inner tube 20 is extruded to form a generally cylindrical tube with inner and outer circumferential surfaces 21 and 22, respectively, and an inner lumen 23 through which the pressurized fluid travels. The first tube 20 further defines a plurality of emitter bodies spaced apart at predetermined intervals with each emitter body having an inlet 41, pressure-reducing flow channel or passage 42 and outlet pool or area 43. In a preferred form, the emitter bodies (including inlets 41, flow channels 42 and outlet pools 43) are embossed in the outer surface 22 of the extruded tube via an embossing wheel or press capable of stamping or pressing the emitter items 41, 42 and 43 into the exterior 22 of the first extruded tube 20 at the desired interval.

**[0035]** After the emitter items are embossed into the exterior 22 of first extruded tube 20, the second tube or jacket 30 is extruded over the first tube 20 enclosing the passageway formed between the inlet 41, flow channel 42 and outlet pool 43 below the inner surface 31 of second tube 30 and leaving only the exterior 32 of second tube 30 visible from the outside of the drip line 10. An opening or bore 44 is made through the second extruded tube 30 proximate the outlet pool 43 so that the flow channel 42 connects the inlet 41 and outlet 44 to form an emitter 40 which will reduce the fluid pressure and flow rate of the fluid passing through the emitter 40. In a preferred form, the second tube 30 seals the first tube and emitter elements 41, 42 and 43 to create a fluid tight passage between the inlet 41 and outlet 44.

**[0036]** In the forms illustrated, the inlet 41 and outlet pool 43 are pressed further into the inner lumen 23 of the first tube 20 than the flow channel 42 to form collecting areas (e.g., baths, pools, etc.) for the fluid passing through the emitter 40 and, in the case of the inlet 41, to allow the inlet 41 to draw fluid from a region other than at a circumferential periphery of the lumen 23 adjacent the inner surface 21 of the first tube 20. Since larger grit and other particulates or particles found in the fluid traveling through the drip line 10 tend to stay near the inside wall 21 of the first tube 20, having the inlet project further into or toward the center of the lumen 23 helps reduce the likelihood that such larger grit or other particulates will enter into and/or clog emitter 40 or prevent it from performing as desired. In addition, by only making the inlet 41 and/or outlet pool 43 extend into the inner lumen 23, the amount of emitter 40 projecting into the lumen 23 is reduced compared to conventional in-line emitters which have their entire body disposed within the drip line, thereby minimizing the amount of interference the emitter 40 introduces into the fluid flowing through the drip line 10 (e.g., turbulence, fluid flow obstruction or increased frictional surface area, etc.).

**[0037]** While the inlet 41 and outlet 44 are shown in a bulbous dome or inverted dome-like form, it should be understood that in alternate forms, these structures may be provided in a variety of different shapes and sizes. For example, as will be discussed further below with respect to FIGS. 3A-D, the inlet and outlet areas may alternatively be rectangular in shape and the inlet may have a funnel-shaped projection or tapering protrusion that allows it to draw fluid closer to the center of the lumen 23 or from a region other than the circumferential periphery of the inner lumen 23. The tapering shape of the inlet further helping to reduce the amount of

interference or noise the inlet and, thus, emitter introduces into the fluid flowing through the emitter and/or drip line. In yet other forms, the emitter **40** may be designed so that only one of the inlet **41** and outlet pool **43**, or neither, extend into the inner lumen **23** of first tube **20** in order to further reduce the amount of interference (e.g., turbulence, etc.) the emitter **40** causes to the fluid flowing through the drip line **10**.

**[0038]** Similarly, while the openings of inlet **41** and outlet **44** shown in FIGS. 1A-E are in the form of round bores, holes or bosses, it should be appreciated that in alternate embodiments the inlet opening and/or outlet opening may take on various different shapes and sizes to accommodate any application. For example, in one form the inlet opening and/or outlet opening may be in the shape of a narrow slit or slot-type opening, or a plurality of slot type openings, through which fluid is allowed to flow. Some of these designs, such as the plurality of slot openings, may be chosen to assist the emitter **40** in deflecting grit and other particulates away from the emitter so that the particulates cannot flow through, clog or interfere with the operation of emitter **40** or drip line **10**. In another form, the inlet opening and/or outlet opening may take on a zigzag tortuous passage shape to further help reduce fluid pressure and flow rate of the fluid entering and/or exiting the emitter **40**.

**[0039]** As best illustrated in FIG. 1B, the pressure-reducing flow channel **42** preferably comprises a tortuous passage defined by opposing baffle walls **42a** and **42b**, respectively. The baffle walls **42a**, **42b** define teeth that force the fluid to zigzag back and forth through the passage **41**; losing fluid pressure with each turn before emptying into the larger outlet area **43** (the transition from smaller passage to larger pool further causing an additional pressure drop). In the form illustrated, the tube **20** is flattened as it is embossed, thus, when the tube is re-formed into a cylindrical tube shape after the embossing process the flow channel **42** (along with inlet **41** and outlet area **43**) becomes curved in accordance with the radius of curvature of tube **20**. This curvature causes the distance between the baffle walls to be closer at the bottom of the flow path (or inner most surface of the flow path) and wider at the top (or outer most surface of the flow path). Meaning the baffle walls will likely not be parallel to one another because of the radius of curvature of the tube **20** and flow path **42**, unless this radius of curvature is accounted for when embossing the emitter elements **41**, **42** and **43**. In addition, in the form illustrated, the upper edge of the teeth is also tapered. It should be understood, however, that in alternate embodiments the flow channel **42** (including its baffle walls, teeth, etc.) may be designed with a variety of different shapes and sizes. For example, in other forms the tortuous passage may define a more curved passageway instead of using a saw tooth type pattern and/or the teeth may have upstream and downstream faces that are not parallel to one another to further assist in pressure reduction. In addition, greater distance may be provided between the baffle walls and/or the distal ends of the teeth to provide a central flow path that allows some of the fluid to flow faster through a portion of the pressure-reducing passage **42** and help clear out grit or other possible obstructions.

**[0040]** In the form illustrated in FIGS. 1A-E, the concentric tubes **20**, **30** have a continuous wall thickness (with the exception of the emitter portion **40**). The first tube **20** preferably has a continuous thickness of twenty thousandths or twenty-five thousandths of an inch (i.e., 0.020" or 0.025") and the second tube **30** preferably has a continuous thickness of fifteen thou-

sandths of an inch (i.e., 0.015") for a total thickness of forty thousandths of an inch (i.e., 0.040"). The channel stamped into the outer diameter of the first tube **20** has a depth that is less than the thickness of the first tube **20** and the inlet extends into the inner lumen **23** (i.e., from the inner diameter of tube **20** to the distal end of the inlet) by an additional ninety-eight thousandths of an inch (0.098"). In addition, the inlet and outlet openings are preferably positioned approximately 3.2" apart from one another and the outer diameter of the jacket **30** is seven-hundred five thousandths of an inch (0.705"). All of these dimensions having a preferred predetermined tolerance (e.g.,  $\pm 0.030$ ",  $\pm 0.015$ ",  $\pm 0.005$ ",  $\pm 1^\circ$ ,  $\pm 0.5^\circ$ , etc.). In alternate forms, however, these dimensions and tolerances may vary depending on the intended application (e.g., residential usage, agricultural usage, commercial or municipal usage, more specific types of applications than these, etc.). For example, in some forms the thickness of the walls may be as thin as ten thousandths of an inch (0.010") and as thick as ninety thousandths of an inch (0.090"), but in a preferred form will range between fifteen thousandths of an inch (0.015") and sixty thousandths of an inch (0.060").

**[0041]** In a preferred form, the thickness of the tubes **20** and **30** is selected so that the completed drip line looks similar to conventional drip line and has a similar wall thickness or inner and outer diameters to conventional drip lines so that the finished product or completed drip line can be used in all conventional irrigation applications and with existing irrigation accessories such as barbed fittings, compression fittings, clamps, stakes, end caps, etc. For example, in one form, inner tube **20** may be designed with a thickness of thirty thousandths of an inch (0.030") and the jacket **30** with a thickness of ten to fifteen thousandths of an inch (0.010"-0.015") for a total thickness of forty thousandths to forty-five thousandths of an inch (0.040"-0.045"), which is a sufficiently thin enough wall thickness to allow for barbed fittings and the like to be used to puncture the drip line where desired. In this form, the passage **42** is stamped into the outer surface of the first tube **20** and has a depth of approximately twenty thousandths to twenty-five thousandths of an inch (0.020" to 0.025") which is then sealed (with the exception of predetermined outlet openings) by outer tube or jacket **30**.

**[0042]** In other embodiments, different dimensions may be selected in order to form an entirely new line or type of drip line with different diameters and wall thicknesses if desired. In addition, it should be understood that in alternate embodiments, the drip line **10** and emitter **40** may be provided with an additional pressure compensating feature if desired. For example, in FIGS. 2A-C, enlarged cross-sectional views of emitter inputs are illustrated for an alternate drip line. For convenience, items which are similar to those discussed above with respect to drip line **10** in FIGS. 1A-E will be identified using the same two digit reference numeral in combination with the prefix "1" merely to distinguish one embodiment from the other. Thus, the inlet of the drip line of FIGS. 2A-C is identified using the reference numeral **141** since it is similar to inlet **41** discussed above with respect to FIGS. 1A-E.

**[0043]** In the form illustrated in FIGS. 2A-C, the first tube layer **120** of drip line **110** is made of an elastomeric material, such as a thermoplastic or thermosetting elastomeric material like materials that use ethylene, propylene, styrene, PVC, nitrile, natural rubber, silicone, etc., to form a polymer or copolymer. In a preferred form, the elastomeric material is made of thermoplastic polyolefin (TPO) and silicone rubber,

which allows the inlet **141** of emitter **140** to collapse in on itself in response to increased fluid pressure to reduce the amount of fluid that can flow through the emitter **140** and, thereby, compensate for supply line fluid pressure increases. In a preferred form, the TPO material allows the dome of inlet **141** to gradually move from a first position, such as the low pressure, expanded or normal position illustrated in FIG. 2A, to a second position, such as the high pressure collapsed position illustrated in FIG. 2C in response to increasing supply line fluid pressure, rather than the inlet dome **141** retaining its shape until a predetermined amount of pressure is reached and then quickly collapsing. To assist in this regard, structural support members, such as ribs **141a**, may be provided to help the inlet dome **141** make such a gradual transition between its normal, low pressure position (FIG. 2A) and its more fully collapsed, high pressure position (FIG. 2C). Thus, as fluid pressure increases, the inlet dome **141** will gradually move from its normal position (FIG. 2A), toward an intermediate position (FIG. 2B) and, ultimately, to its more fully collapsed position (FIG. 2C) when the fluid pressure reaches a predetermined level. The ribs **141a** are also designed as an obstruction or stop for preventing the inlet dome **141** from collapsing so fully on itself as to stop the flow of fluid through emitter **141**. When pressure decreases, the dome inlet **141** gradually returns to its normal, low pressure shape as illustrated in FIG. 2A by moving from its more fully collapsed position (FIG. 2C) toward its intermediate position (FIG. 2B) and then, eventually, back to the normal position (FIG. 2A) once the fluid pressure has dropped below a predetermined level. In this regard, the dome inlet **141** allows drip line **110** to compensate for fluctuations in supply line fluid pressure by moving between the positions illustrated in FIGS. 2A-C as supply line fluid pressure increases and decreases.

[0044] It should be understood that in alternate embodiments, the ribs **141a** or alternate support structures may be placed on the outside surface of the inlet dome **141** exposed to the supply line fluid flowing through inner lumen **123** rather than on the inside surface of inlet dome **141**. In addition, other types of support structures or framing, such as internal or external latticework, endoskeletons or exoskeletons, etc., may be used to accomplish either the task of allowing gradual transition of the inlet dome between its low pressure position (FIG. 2A) and its high pressure position (FIG. 2C) or the task of preventing the inlet dome from fully collapsing on itself and preventing fluid from flowing through emitter **140**. In still other embodiments, no support structures may be used. This may be in situations where the dome material itself is enough to ensure the gradual transition between low and high pressure positions (FIGS. 2A, 2C respectively), or in situations where a quicker transition is desired between low pressure and high pressure positions (e.g., such as the situation discussed above where the dome retains its lower pressure shape, FIG. 2A, until a predetermined pressure is reached and then immediately collapses to its high pressure position, FIG. 2C, without going through a gradual transition).

[0045] Although a dome has been illustrated for the inlets **41** and **141** of FIGS. 1A-E and FIGS. 2A-C, respectively, it should be understood that the inlet may be provided in a variety of different shapes and sizes and does not have to play a role in pressure compensation. Similarly, in other forms, the drip emitter may be constructed of tubes of varying wall thickness rather than of uniform thickness as shown in FIGS. 1A-E and 2A-C. For example, in FIGS. 3A-D, an alternate

form of drip line is illustrated having an inlet opening with a rectangular and funnel shape inlet and having an inner tube with a varying wall thickness. As with the above-described alternate embodiment, items of the alternate embodiment of FIGS. 3A-D which are similar to those discussed above with respect to drip lines **10**, **110** in FIGS. 1A-E and 2A-C will be identified using the same two digit reference numeral in combination with the prefix “2” merely to distinguish one embodiment from the other. Thus, in FIGS. 3A-D, the drip line and emitter will be identified using reference numerals **210** and **240** since they are similar to the drip lines **10**, **110** and emitters **40**, **140** discussed above with respect to FIGS. 1A-E and 2A-C, respectively.

[0046] In the form illustrated in FIGS. 3A-D, the inner tube **220** of drip line **210** is stamped or embossed with an emitter **240** having a generally rectangular inlet **241** that has a funnel shaped portion **241b** extending from the rectangular portion of the inlet **241** further into the lumen **223** so that fluid is drawn from a region other than at a circumferential perimeter of lumen **223** and away from the inner wall **221** of tube **220** where grit and other particulates are less likely found (i.e., as mentioned above grit and particulates that can clog the emitter are more frequently found near the inner wall **221** of inner tube **220**).

[0047] In this form, the funnel shaped inlet **241** does not collapse on itself to form a pressure-compensating structure, but rather the floor of pressure-reducing flow channel **242** deflects into the flow channel **242** to reduce the cross-section of the flow channel **242** in response to increases in supply line fluid pressure, thereby compensating for pressure increases. As best illustrated in FIG. 3B, at low fluid pressures, the floor of the flow channel **242** remains at its normal position wherein the cross-section of the flow channel is maximized to allow as much fluid as possible to flow through the flow channel **242** and into outlet **243**. As fluid pressure increases, the floor of flow channel increasingly deflects into the flow channel **242**, as illustrated in FIG. 3C, thereby reducing the cross-section of the flow channel **242** and limiting the amount of fluid that is allowed to pass through the flow channel **242** and into outlet **243**. In a preferred form, the deflection of the floor of flow channel **242** will not be enough to fully close or collapse the flow channel **242** and prevent all fluid from passing through the emitter **240**, however, the floor of the flow channel **242** will gradually deflect further and further into the flow channel **242** as the fluid pressure increases; thereby reducing the cross-section of the flow channel **242** and limiting the amount of fluid that can flow therethrough in order to compensate for fluid pressure increases. Conversely, as fluid pressure decreases, the floor of flow channel **242** will gradually return more and more toward its normal position (i.e., FIG. 3B) to allow more fluid to flow through the emitter **240**. Thus, in this way, the emitter **240** and drip line **210** are capable of compensating for fluctuations in fluid pressure.

[0048] Obstructions, such as stops **245**, are used to prevent the inlet **241** and outlet pool **243** from collapsing in on themselves. In the form illustrated the stops **245** are in the form of projections or posts that extend up from the floor of the inlet **241** and outlet **243** and are formed during the embossing process. If desired, the posts **245** may be spaced apart from one another by an amount sufficient to allow the floor of the inlet **241** and outlet pool **243** to deflect inwards and reduce the cross-section of the inlet **241** and outlet **243**, respectively, in order to further compensate for increases in supply line fluid pressure and/or assist in pressure compensation for emitter



**240.** In this way, the first pressure compensating mechanism of FIGS. 2A-C may be combined with the pressure compensating mechanism illustrated in FIGS. 3A-D to provide both an inlet **241** and flow channel **242** that compensate for supply line fluid pressure fluctuations and/or may be combined with a deflecting outlet **243** (which could be similar to the deflecting inlets **141** and **241** described herein) to provide yet another type of pressure compensating structure. Alternatively, posts **245** may be placed closer together to prevent the floor of inlet **241** and/or outlet **245** from deflecting inwards in response to increases in supply line fluid pressure so that the cross-section of the inlet **241** and outlet **243** remain generally constant regardless of fluid pressure fluctuations.

**[0049]** As with earlier embodiments, fluid traveling through the drip line **210** of FIGS. 3A-D will travel through the inner lumen **223** with some fluid passing through inlet **241**, then through flow channel **242** and collecting in outlet pool **243**. When the drip line **210** is manufactured, an outlet bore or boss **244** is formed in the outer tube layer **230** so that fluid can pass from the outlet pool **243** to the surrounding environment of outlet **244** via the bore extending between inner surface **231** and outer surface **232** of outer tube **230**. In the form illustrated, the outlet pool **243** is generally rectangular in shape, however, just with the inlet **241**, the outlet **243** may be provided in a variety of different sizes and shapes. For example, in the embodiment of FIGS. 1A-E the outlet pool **43** is pressed further into the lumen **23** of the inner tube **20**. Whereas in the embodiment of FIGS. 3A-D, the outlet pool **243** does not extend into lumen **223** and allows the inner tube **220** (and therefore drip line **210**) to maintain a constant inner diameter to minimize the risk of the emitter **240** adding turbulence to or interfering with the fluid passing through the lumen **223** and, thus, further helping to ensure that every emitter stamped into the drip line **210** will operate in a similar manner (e.g., ensuring the last emitter in the drip line will work as well as the first emitter). Similarly, in FIGS. 3A-D, the inlet portion that extends into the lumen **223** is minimized to just that of the funnel or frustoconical portion **241b** in an effort to reduce any negative effects the emitter **240** may have on the system **210**. For example, the tapered design of funnel portion **241b** should minimize the amount of disturbance the emitter inlet **241** causes on the fluid passing through lumen **223** and should prevent grit or other particulates from building-up on and/or clogging the emitter and drip line or interfering with the desired performance of the emitter **240** and drip line **210**.

**[0050]** In the form illustrated in FIGS. 3A-D, drip line **210** is configured with an inner tube **220** that has varying wall thickness. More particularly, in the form illustrated the wall portion of tube **220** into which the emitter **240** is stamped is thicker than the wall thickness of the remaining portions of tube **220**. As best illustrated in FIG. 3D, the inner tube **220** has a constant or predominantly constant wall thickness that transitions to a variable thickness portion at the upper portion of tube **220**. For example, in the form illustrated a two-hundred and forty degree ( $240^\circ$ ) portion of inner tube **220** has a constant wall thickness of thirty-thousandths of an inch (0.030") while a one-hundred twenty degree ( $120^\circ$ ) portion, designated by reference a°, has a thicker wall portion. More particularly, designation b° represents an eighty degree ( $80^\circ$ ) portion where the wall thickness is at a constant increased thickness of forty-five thousandths of an inch (0.045") and designation c° represents two separate twenty degree ( $20^\circ$ ) portions (one on each side of the b° portion) wherein the wall

thickness transitions from the constant smaller wall thickness of thirty thousandths of an inch (0.030") to the constant larger wall thickness of forty-five thousandths of an inch (0.045"). In the form illustrated, the outer tube **30** has a constant wall thickness of fifteen-thousandths of an inch (0.015") all the way around the tube **30**. Meaning that the inner tube **20** transitions from a constant smaller thickness of fifteen thousandths of an inch (0.015") near the bottom of the drip line **210** to a constant larger thickness of thirty thousandths of an inch (0.030") at the top of the drip line **210**.

**[0051]** It should be understood that these dimensions (e.g., degrees, inches, etc.) are simply an exemplary embodiment and that in alternate embodiments various different dimensions may be used. For example (and as mentioned above), alternate drip lines may be provided with wall thicknesses that vary anywhere from ten thousandths of an inch (0.010") to ninety thousandths of an inch (0.090") and the various degrees of each portion may be altered as desired. In addition, instead of having a one-hundred twenty degree ( $120^\circ$ ) portion of increased thickness, tube **20** may be provided with larger or smaller portions of various thicknesses (e.g., smaller thicknesses, larger thicknesses, transitioning zones of varying thicknesses, etc.) as desired for particular applications.

**[0052]** Some benefits of providing the inner tube **20** with a thickened wall portion is that it provides more material for the emitter to be stamped in, and so, larger flow channels (e.g., taller, wider, longer flow channels, etc.) can be provided to accommodate different intended applications for the drip line. For example, in one form the additional material provided by the thickened wall portion may be used to press a U- or other shaped flow channel into the outer surface **222** of first tube **220**. Alternatively, it may be used to stamp a tapered (or tapering) flow channel **242** that either allows fluid to flow over the top of the tapered baffle portion at low supply line fluid pressure or deflects up along with the floor of the flow channel **242** as supply line fluid pressures increase to sequentially close baffles against the inside surface **231** of outer tube **230** in order to lengthen the tortuous passage defined by the flow path **242** and compensate for the increase in supply line fluid pressure. Examples of various embodiments of such movable flow channel baffle structures are disclosed in U.S. patent application Ser. No. 13/430,249 filed Mar. 26, 2012 by Ensworth et al. and entitled ELASTOMERIC EMITTER AND METHODS RELATING TO SAME, which is hereby incorporated herein by reference in its entirety. In addition, the thickened wall portion around the emitter **240** should help provide further structural support for the emitter and/or reduce the risk of cracking, tearing or other fractures/fissures forming around, on or near the emitter **240** when the drip line **210** is manufactured and/or used (whether above ground or subsurface). The added material may also allow the inlet opening to be extended further into the lumen **223** of the drip line **210** such as by way of a larger funnel or bulb inlet portion which may help reduce the likelihood of grit or other particulates from clogging the emitter or interfering with the emitter's performance. In addition, the thickened portion may simply provide for more space and material to emboss larger inlets, outlets, etc.

**[0053]** It should also be understood that in alternate embodiments, various different combinations of constant and variable wall thickness may be used as desired. For example, in FIGS. 4A-C, a drip line is illustrated at various stages of its manufacture in which the inner tube **320** goes from being a tube of variable wall thickness to a tube of generally constant

wall thickness after the emitter is pressed into the outer surface **321** of inner tube **320**. More particularly, in FIG. 4A, an inner tube **320** is illustrated having variable wall thickness in which a predominant portion of the tube has a constant smaller wall thickness and a smaller portion of the tube has a larger wall thickness. In keeping with the above practice, items similar to those discussed in earlier embodiments will use the same two-digit reference numeral with the addition of prefix “3” to distinguish one embodiment from the other.

[0054] Once the emitter **340** is stamped or embossed into the outer surface **321** of tube **321** at the thickened wall portion, the tube **320** is left with a generally constant wall thickness as illustrated in FIG. 4B (with the exception of the emitter inlet portion **341b**). Then the inner tube **320** is over-extruded with an outer tube **330** of constant wall thickness to enclose or seal the emitter **340** (e.g., emitter inlet **341**, flow path **342** and outlet pool **343**). In this way, a drip line **310** is provided with generally constant wall thickness with the exception of the inlet funnel **341b**. It should be understood that in alternate embodiments, the inlet **341** does not need to extend into the lumen **323** of drip line **310** if desired. Rather, the inlet **341** could be shaped without a projecting portion or protrusion if it is preferred to keep the inner diameter of the inner tube **320** (and therefore drip line **310**) constant throughout and to ensure that the emitter **340** has minimal (if any) negative effect (e.g., generation of turbulence, slowing of fluid flow, etc.) on the fluid flowing through lumen **323**.

[0055] Yet another embodiment is illustrated in FIG. 5 in which the inner tube **420** is provided with constant wall thickness (whether it be from the start as with the embodiment of FIGS. 1A-E or after embossing as with the embodiment of FIGS. 4A-C) and an outer tube **430** is provided with variable wall thickness. In keeping with the above practice, items similar to those discussed in earlier embodiments will use the same two-digit reference numeral with the addition of prefix “4” to distinguish one embodiment from the other. In this form, the wall thickness of outer tube **430** is thickened near the emitter **440** to provide further structure support for the emitter **440** and/or reduce the risk of cracking or other fractures forming around the emitter **440** when the drip line **410** is manufactured and/or used (whether above ground or subsurface).

[0056] Still another embodiment is illustrated in FIG. 6 in which both the inner tube **520** and outer tube **530** are provided with thickened wall portions located proximate the emitter **540**. In keeping with the above practice, items similar to those discussed in earlier embodiments will use the same two-digit reference numeral with the addition of prefix “5” to distinguish one embodiment from the other. This should provide the benefits described above with respect to having a thickened inner tube wall **520** (e.g., more material to press the emitter into which gives greater options for height, width, length of emitter, etc.) and outer tube wall **530** (e.g., stronger more supported emitter, more resistant to cracking or other fracturing during manufacture and use of drip line including subsurface applications, etc.). In addition, it likely will make the emitter portion **540** (if not the entire drip line **510**) capable of handling supply line fluids with higher pressures given the reinforcing provided by the thickened wall portions of tubes **520**, **530** and/or may make the drip line **510** capable of withstanding greater amounts of force, such as when being buried further under ground and/or under heavily trafficked areas or areas exposed to greater forces of mass, etc.

[0057] One advantage to the embodiments discussed herein is that the finished tubing product “is” the emitter or drip line and no additional structures (e.g., in-line emitter bodies or multi-piece structures, on-line/branch emitters, etc.), need to be added to the tubing to create an emitter or drip line. Thus, the complicated and costly steps and materials required for assembling conventional emitters and drip lines can be avoided and replaced with a process for manufacturing or assembling tubing that is, itself, the emitter and/or drip line. In addition, the lack of additional structures (e.g., such as emitter bodies or barbed fittings extending into the lumen, etc.) and multi-piece structures (e.g., such as multi-piece emitter housings with elastomeric diaphragms, etc.), gives the emitter and drip line disclosed herein an improved grit tolerance or ability to avoid having the presence of grit interfere with the operation of the emitters of the drip line. For example, by removing the in-line emitter or barbed end of a branch emitter from the inner lumen of the drip line, grit cannot build-up on these structures and reduce fluid flow through the drip line or emitters. A burst pressure can further be applied to the emitter and drip line disclosed herein to flush grit more easily due to this simplified structure.

[0058] An exemplary setup for manufacturing the drip line disclosed herein is illustrated in FIG. 7. In keeping with the above practice, items similar to those discussed in earlier embodiments will use the same two-digit reference numeral with the addition of prefix “6” to distinguish one embodiment from the other. In this form, a plastic inner tube **620** is extruded using conventional extrusion processes and having an inside wall **621** and an outside wall **622**. The inner tube **620** is then pressed, stamped or embossed via a molding structure, such as embossing wheel **670**, to form an emitter inlet **643**, pressure-reducing flow channel **642** and outlet pool or bath **643** in or on the exterior surface **622** of inner tube **620**. As mentioned above, the inner tube **620** may be flattened or deformed as a result of the pressing/stamping/embossing stage and, thus, the tube **620** may have to be re-formed into a generally cylindrical tube. After this is done, the tube **620** is passed through a separate mold wherein an second outer tube **630** is extruded over the inner tube **620** thereby enclosing or sealing the inlet **641**, flow channel **642** and outlet pool **643** of the emitter **640** so that all fluid flowing from inlet **641** to outlet pool **643** must flow through flow channel **642**. Then a bore or hole **644** is punched through the outer tube **630** to complete the emitter **640** and provide an egress channel for fluid to flow out of the drip line **610** and to the surrounding environment in which the drip line **610** is placed.

[0059] Although the above identifies one exemplary method in which the drip line and emitter may be manufactured, it should be understood that many alternate methods of manufacturing such a drip line and/or emitter exist. For example, although the above description has primarily discussed the embossing of emitter parts on an outer surface of an inner tube, it should be understood that in alternate methods of manufacture the emitter and/or emitter parts may be created via a variety of different press or stamping methods, by etching or milling methods, etc. In addition, in other forms, the drip line and/or emitter may be manufactured by stamping an emitter design on an inside surface of a tube either as that tube is extruded over another tube to enclose the emitter portions or as another tube is extruded on the inside of that tube to enclose the emitter portions.

[0060] In yet another form, the drip line and/or emitter may be manufactured by stamping an inside surface of the tube to

form a structure that extends out from the outer surface of the tube. For example, in the alternate form illustrated in FIG. 8 (which in keeping with the above practice uses the same two-digit reference numerals to identify items similar to those discussed above and adds prefix "7" to distinguish this embodiment from the others), a male die is positioned on the inner surface 721 of inner tube 720 and a corresponding female die is positioned on the outer surface 722 of the inner tube 720 to form baffle walls 742a, 742b extending upward or outward from the outer surface 722 of the inner tube 720. These walls 742a, 742b define a tortuous flow path or channel 742 that is then covered by an outer tube or jacket 730 extruded over the inner tube 720 to form an enclosed emitter 740. In a preferred form, the raised walls are of a sufficient height to create a pressure-reducing flow channel that is twenty thousandths of an inch to twenty-five thousandths of an inch (0.020" to 0.025") deep.

[0061] In addition to forming baffle walls 742a and 742b, the raised walls formed during the stamping or embossing process also form at least portions of inlet area 741 and outlet area 743 so that fluid flowing through the inner lumen 723 flows through the inlet 741 and flow channel 742 and exits the emitter 740 at outlet opening 744 which is formed in the outer tube or jacket 730 of the drip line 710 in a manner similar to that discussed above. Thus, in the form illustrated, neither the inlet 741 nor the outlet 743 extends into the inner lumen 723 of the drip line 710 and the floor of the flow channel 742 has the same outer diameter as the remainder of the inner tube 720 (with the exception of where the raised walls extend from the outer surface of tube 720).

[0062] It should be understood, however, that in alternate embodiments, the raised walls do not have to form a perimeter wall defining at least a portion of the inlet area 741, outlet area 743 and pressure-reducing flow channel 742 (as depicted in FIG. 8), but rather may be used to define any one or more of these items and/or portions of these items. For example, in some forms a mixture of recessed areas and raised walls may be used to form the emitter 740. More particularly and as one example, the inlet area 741 and outlet area 743 in one form of emitter may be recessed into the exterior surface of the inner tube 720 (possibly even extending into the inner lumen 723 of tube 720 as discussed in above embodiments) while the pressure-reducing flow channel 742 is formed by raised walls extending between the inlet area 741 and outlet area 743. Transition areas may exist where the inlet and outlet areas connect to the pressure reducing flow channel to ensure that fluid flows between the inlet and outlet as desired and is not obstructed once the outer tube or jacket 730 is extruded over the inner tube 720. For example, portions of the flow channel adjacent the inlet and outlet areas might be recessed in these transition areas to ensure fluid flows through the emitter 740 as desired. Alternatively, portions of the inlet and outlet areas 741, 743 may be surrounded by raised walls, such as walls that taper in height, in these transition areas in order to ensure fluid flows through the emitter 740 as desired. In still other forms, a combination of recessed portions of flow channel 742 and raised walls near the inlet and/or outlet areas 741, 743 may be used in these transition areas in order to ensure fluid flows through the emitter 740 as desired.

[0063] In still other forms, at least a portion of one or more of the inlet area 741, pressure reducing flow channel 742 and outlet area 743 may be made up by a combination of raised and recessed portions separate and apart from the above mentioned transition areas (if such transition areas are even

present). For example, the pressure-reducing flow channel 742 could be partially recessed in the exterior surface 722 of the inner tube 720 and partially formed by walls extending from the exterior surface 722 of the inner tube 720. Such a design would be particularly desirable in applications where a flow passage of maximum cross-section is desired without increasing the overall wall thickness of the drip line 710 (i.e., the combined thickness of both the inner and outer tubes 720, 730). Pressure compensating features like those discussed above could also be added if desired.

[0064] Furthermore, the thickness of the inner and outer tubes 720, 730 may be uniform or may vary in different embodiments. In one form, the outer tube 730 will be of uniform thickness and the inner tube 720 will be of variable thickness with the majority of the inner tube 720 having uniform thickness but the portion of the inner tube 720 into which the emitter 740 is to be stamped between the male and female dies being of greater thickness. In an alternate form, however, the inner tube 720 will be of uniform thickness and the outer tube 730 will be of variable thickness with the majority of the outer tube 730 being of uniform thickness and the portion of the outer tube 730 proximate the stamped emitter 740 being of greater thickness. While these are the preferred configurations for the forms of the emitter and/or drip line of FIG. 8, it should be understood that in other forms the tubes 720, 730 may both be of uniform thickness or both be of variable thickness as mentioned above with respect to prior embodiments. It should also be understood that, like the embodiments discussed above, the thickness of the tube walls will be selected such that it withstands the fluid pressures the emitter and drip line will be subject to for its intended application. Thus, if an inner tube with a thickened wall is required or an outer tube with a thickened wall is required (or some combination thereof) in order to withstand the fluid pressures that the drip line will be subject to (e.g., initial start-up fluid pressure, maximum service line fluid pressure, burst pressure or pressure of air used to winterize the line, etc.), then such thickened walls will be used.

[0065] One benefit to the configuration of FIG. 8 is that it allows the backside of the stamped structure to be used to form the emitter, which can often be cleaner than the front side or recessed side of the stamped structure (e.g., free of defects such as tears, sharp edges, dull or rounded edges, variations in edges, etc.) and/or can be more readily reproduced uniformly or without variance (e.g., reproduced in a repeatable fashion without much or any discrepancy from one version to another). For example, in some instances the walls of a stamped recess may vary from sharp edges to dull or rounded edges on the front side of the stamping, whereas the structure on the backside of the stamping is uniform and does not have walls or recesses that vary in shape, size, texture, etc. The ability to reproduce the emitters uniformly is desirable so that each emitter works the same and one does not drip more fluid than another on the same drip line.

[0066] Similarly, in yet other forms, an emitter may be formed on or in the inner or outer surface of a tube and then the tube may be pulled inside-out to put the emitter portions on either an outer or inner surface of the tube and then extruding another tube layer to enclose the emitter portions. In still other forms, a portion of the emitter may be injection molded and then inserted into the extruded drip line in order to form an enclosed emitter. For example, an elastomeric material may be injection molded and then inserted into a tube extru-

sion (e.g., bonded to an inner surface of the tube extrusion) in order to form an enclosed emitter with the features described herein.

**[0067]** One method of manufacturing a drip line disclosed herein comprises extruding a first tube layer having inner and outer surfaces and defining an inner lumen through which fluid may flow, embossing a plurality of inlets and pressure-reducing flow channels having first and second ends on an exterior surface of the first extruded tube layer, with each inlet being located at the first end of a corresponding pressure-reducing flow channel and the plurality of inlets opening on one end to the inner lumen defined by the inner surface of the first extruded tube layer and on an opposite end to the first end of the corresponding pressure-reducing flow channel, and sized to receive pressurized fluid from the inner lumen, extruding a second tube layer over the first tube layer to enclose the plurality of inlets and flow channels, and making outlet openings in the second extruded tube layer near the second end of each pressure-reducing flow channel so that the flow channel extends between the inlet and outlet for reducing the pressure and flow of fluid received at the inlet and discharged through the outlet.

**[0068]** In one form the first tube layer has a variable wall thickness, with a first thickened wall portion and a second thinner wall portion, and embossing the plurality of inlets and pressure-reducing flow channels comprises embossing the plurality of inlets and pressure-reducing flow channels into the first thickened portion of the first extruded tube layer. As mentioned above, the method of embossing the inlets and flow channels into the first tube layer may be selected from a variety of different methods. In a preferred form, the embossing step comprises pressing the inlet opening into the outer surface of the first extruded tube layer to form an inlet that projects into the inner lumen of the first extruded tube layer so that the fluid received at the inlet comes from a region other than at a circumferential periphery of the lumen adjacent the inner surface of the first tube in order to avoid grit and other particulates that are typically found near the inner surface of the first tube.

**[0069]** In addition to the above embodiments and methods, it should be understood that various methods of assembling irrigation drip lines, methods of compensating for pressure in a supply line (e.g., increases or decreases in supply line fluid pressure), methods of manufacturing an emitter and methods of reducing fluid flow pressure are also disclosed herein. For example, there is disclosed herein several methods of compensating for pressure fluctuations in supply line fluid pressure in irrigation drip lines and emitters. In one form, a method is disclosed comprising providing an emitter and/or drip line in accordance with those discussed above and including a method of compensating for fluctuation of supply line fluid pressure by moving the inlet between a first position wherein the inlet has a large cross-section and allows in a large amount of fluid, and a second position wherein the inlet has a smaller cross-section and allows in less fluid.

**[0070]** In another example, a method of compensating for fluid is disclosed comprising providing an emitter and/or drip line in accordance with those discussed above and compensating for fluctuation of supply line fluid pressure by moving at least a portion of the first tube between a first position wherein the at least a portion of first tube is spaced apart from the closest portion of the second tube by a first amount and a second position wherein the at least a portion of the first tube is spaced apart from the closest portion of the second tube by

a second amount smaller than the first amount to compensate for an increase in fluid pressure. The at least a portion of the first tube may include individually and/or any combination of the floor of the flow channel, at least a portion of the floor of the inlet and/or at least a portion of the floor of the outlet pool.

**[0071]** In yet another example, a method of compensating for fluid is disclosed comprising providing an emitter and/or drip line in accordance with those discussed above and compensating for fluctuation of supply line fluid pressure by moving a tapered structure between a first position wherein the tapered structure is not in engagement with an inner surface of the second extruded tube and fluid is allowed to flow over the tapered structure and a second position wherein the tapered structure is in at least partial engagement with the inner surface of the second extruded tube so that fluid does not flow over the portion of the tapered structure that is in engagement with the inner surface of the second extruded tube and the cross-section of the flow channel is reduced and/or the length of the flow channel is lengthened.

**[0072]** In another form, a method is disclosed for manufacturing an emitter and/or drip line comprising extruding an inner tube, applying a male die to the inside surface of the inner tube and a corresponding female die to the outside surface of the inner tube in alignment with the male die to form a raised structure, such as one or more of the inlet area, flow passage or outlet area (or portions thereof), extending from the outer surface or outside surface of the inner tube and then extruding an outer tube or jacket over the inner tube to enclose the raised structure to form an emitter having an inlet open to the inner lumen of the tube and an outlet opening through the outer tube, with the flow passage extending between the inlet and outlet. The female die side of the inner tube being used to form the flow channel of the emitter rather than the male die side of the inner tube in order to provide a cleaner structure that can be more readily and uniformly reproduced from emitter to emitter.

**[0073]** An opening may have to be made in the outer extruded jacket or tube to form the outlet bore or opening (as discussed in above embodiments) in order to complete the emitter so that water can flow from the inner lumen, through the inlet, through the pressure-reducing flow channel and then out the outlet of the emitter. In the form illustrated, the inner and outer tubes will be at least partially flattened when the male and female dies are pressed or stamped to form the emitter structure and/or when the outlet opening is made in the outer jacket or tube. Thus, the method may further include re-rounding the at least partially flattened tubes into a rounded drip line having multiple emitters spaced along the drip line at a predetermined or desired interval (e.g., uniformly spaced, non-uniformly spaced, staggered, etc.). In a preferred form, the emitters will be located along a straight line uniformly spaced apart from one another. However, in alternate forms, the tubes may be rotated during the manufacturing process in order to stagger the emitters so that they are not all located in a straight line if desired.

**[0074]** In the above examples, it should be clear that movement of movable structures (e.g., inlet dome, flow channel floor, inlet floor, outlet pool floor, tapered baffle portions, etc.) to compensate for fluid pressure increases and decreases can either be complete movements from a first limit of travel to a second limit of travel (i.e., from a furthest most open position to a furthest most closed position and vice versa), or alternatively, may simply be movements toward one or more of those limits of travel without those limits actually having been

reached (i.e., movement toward a furthest most open position to a furthest most closed position and vice versa). In addition, the material chosen for the movable bodies may be selected such that such movement happens at a desired pace. For example, if a quick opening and closing is desired, a material that is more flexible or has a lower Durometer value may be selected. Whereas, if a slower or more gradual opening and closing (or transitioning from one or the other) is desired, a material that is less flexible or that has a higher Durometer value may be selected. Similarly, support structure such as lattice framework, internal ribs, exoskeletons, endoskeletons, etc. may be added to help assist in making such movement at the desired pace. Furthermore, as mentioned above, in a preferred form the emitter and/or drip line will not include pressure compensating features and will simply comprise a non-pressure compensating emitter and/or drip line capable of being produced more easily than conventional emitters and drip lines.

**[0075]** In addition to the above embodiments and methods it should be understood that these embodiments and methods may be used to produce emitters and drip lines that allow fluid to flow at different rates for different applications. For example, smaller or larger flow channel cross-sections may be provided, longer and shorter flow channels may be used, materials with different Durometer readings may be used, etc. In order to distinguish these product lines, color may also be added to the embodiments and methods of manufacturing same to distinguish one product line from another. For example, one color may be used to identify an emitter or drip line that drips at a rate of one gallon per hour (1 GPH), another color may be used to identify an emitter or drip line that drips at a rate of two gallons per hour (2 GPH), another color may be used to identify an emitter or drip line that drips at four gallons per hour (4 GPH). In addition some colors may be used to signify the source of water for a particular application. For example, the color purple is often used to indicate that reclaimed or recycled water is being used. If desired, any of the above embodiments and methods could include the addition of color for such purposes.

**[0076]** Many different embodiments and methods have been provided herein, however, it should be understood that these are not exhaustive and that many more alternate embodiments and methods in accordance with the disclosure set forth herein are contemplated in the appended claims. For example, of the numerous different concepts discussed, it should be understood that alternate embodiments are contemplated that utilize any one of these concepts on their own or combine, mix or match any number of these concepts in different ways.

**[0077]** Thus it is apparent that there has been provided, in accordance with the invention, a drip line and/or emitter and methods relating to same that fully satisfy the objects, aims, and advantages set forth above. While the invention has been described in conjunction with specific embodiments thereof, it is evident that many alternatives, modifications, and variations will be apparent to those skilled in the art in light of the foregoing description. Accordingly, it is intended to embrace all such alternatives, modifications, and variations as fall within the spirit and broad scope of the appended claims.

What is claimed is:

1. An irrigation drip emitter for converting fluid flowing at a high flow rate to a low flow rate, comprising:
  - a first extruded tube layer defining an inlet and a pressure-reducing flow channel on an exterior surface thereof

- with the inlet and flow channel each having first and second ends and the second end of the inlet being connected to the first end of the flow channel, and the first end of the inlet opening to an inner lumen defined by an inner surface of the first tube layer and sized to receive a desired amount of pressurized fluid from the inner lumen; and

- a second tube layer extruded over the first tube layer and enclosing the inlet and flow channel, the second tube layer defining an outlet connected to the second end of the flow channel so that the flow channel extends between the inlet and outlet to create an emitter for converting fluid flowing at a high flow rate in the lumen and at the first end of the inlet to a fluid with a low flow rate at the outlet of the emitter.

2. An irrigation drip emitter according to claim 1 wherein the inlet defined by the first tube layer comprises an elongated bore that extends at the first inlet end into the inner lumen so that the fluid received at the inlet comes from a region other than at a circumferential periphery of the lumen adjacent the inner surface of the first tube.

3. An irrigation drip emitter according to claim 2 wherein at least one of the inner and outer tube layers is of variable thickness with a thickened portion being positioned proximate to at least one of the inlet, flow channel and outlet, the thickened portion being thicker than a remaining portion of the inner and outer tube layers.

4. An irrigation drip emitter according to claim 3 wherein the portion of the inner tube layer defining the inlet and flow channel is thicker than the remaining portion of the inner tube layer and the outer tube layer is of generally constant thickness.

5. An irrigation drip emitter according to claim 3 wherein the portion of the outer tube layer enclosing the inlet and flow channel is thicker than the remaining portion of the outer tube layer.

6. An irrigation drip emitter according to claim 1 wherein the inner tube layer is made of an elastomeric material capable of deflecting into the flow channel in response to an increase in pressure of the pressurized fluid traveling through the inner lumen thereby reducing the cross-sectional area of the flow channel as fluid pressure increases.

7. An irrigation drip emitter according to claim 6 wherein at least one of the inner and outer tube layers defines baffle walls that form at least a portion of the flow channel and the deflection of the elastomeric material into the flow channel further causes at least a portion of the baffle walls to move and effectively lengthen the flow channel to compensate for increasing fluid pressure.

8. An irrigation drip emitter according to claim 6 wherein at least one of the inner and outer tube layers defines stops or obstructions for preventing at least a portion of the inlet and at least a portion of an outlet area from completely collapsing in response to increasing fluid pressure.

9. An irrigation drip emitter according to claim 8 wherein the stops or obstructions are posts extending from a surface of the at least one of the inner and outer tube layers for preventing the at least a portion of the inlet and the at least a portion of the outlet area from completely collapsing in response to increasing fluid pressure.

10. An irrigation drip emitter according to claim 6 wherein the inner tube layer further defines ribs positioned proximate to the inlet for allowing the inlet to partially, but not com-

pletely, collapse in response to increasing fluid pressure in order to compensate for fluctuations in fluid pressure.

**11.** An irrigation drip emitter according to claim 1 wherein the inner tube layer defines a plurality of additional inlets and pressure-reducing flow channels on the exterior surface thereof, each additional inlet and pressure-reducing flow channel having first and second ends, with the second end of each additional inlet being connected to the first end of one of the additional pressure-reducing flow channels to form an inlet and corresponding flow channel, and the first end of each additional inlet opening to the inner lumen defined by the inner surface of the first tube layer and sized to receive a desired amount of the pressurized fluid from the inner lumen, with each inlet and corresponding flow channel being space apart from the other inlets and corresponding flow channels at predetermined intervals; and

a second tube layer extruded over the first tube layer and enclosing the additional inlets and flow channels, the second tube layer defining a plurality of outlets with each outlet connected to the second end of one of the corresponding flow channels so that the corresponding flow channel extends between one inlet and one outlet to create a drip line having a plurality of emitters for converting the fluid flowing at the high flow rate in the lumen and at the first end of the inlets to fluid with the low flow rate found at any of the outlets.

**12.** An irrigation drip emitter according to claim 1 wherein the pressure-reducing flow channel defined by the first extruded tube is recessed into the exterior surface of the first extruded tube.

**13.** An irrigation drip emitter according to claim 1 wherein the pressure-reducing flow channel defined by the first extruded tube is formed by a wall extending from the exterior surface of the first extruded tube.

**14.** An irrigation drip emitter according to claim 1 wherein at least a first portion of the inlet or pressure-reducing flow channel is recessed into the exterior surface of the first extruded tube and at least a second portion of the inlet or pressure-reducing flow channel is formed by a wall extending from the exterior surface of the first extruded tube.

**15.** An irrigation drip line comprising:

a first extruded tube layer defining a plurality of inlets and pressure-reducing flow channels on an exterior surface thereof with each pressure-reducing flow channel being located proximate to one of the plurality of inlets, the plurality of inlets opening to an inner lumen defined by an inner surface of the first tube layer and sized to receive pressurized fluid from the inner lumen; and

a second tube layer extruded over the first tube layer and enclosing the plurality of inlets and flow channels, the second tube layer defining a plurality of outlets with each outlet positioned adjacent to one of the proximate flow channels on an end of the flow channel opposite one of the plurality of inlets so that the flow channel extends between one of the plurality of inlets and one of the plurality of outlets to create an emitter for reducing the

pressure and flow of fluid received at the plurality of inlets by the time the fluid is discharged through the plurality of outlets.

**16.** A method of manufacturing a drip line comprising: extruding a first tube layer having inner and outer surfaces and defining an inner lumen through which fluid may flow;

embossing a plurality of inlets and pressure-reducing flow channels having first and second ends on an exterior surface of the first extruded tube layer, with each pressure-reducing flow channel being connected to one of the plurality of inlets at the first end each of the pressure-reducing flow channels to form a corresponding flow channel for each inlet, and the plurality of inlets opening to the inner lumen defined by the inner surface of the first extruded tube layer and sized to receive pressurized fluid from the inner lumen;

extruding a second tube layer over the first tube layer to enclose the plurality of inlets and flow channels; and making outlet openings in the second extruded tube layer near the second end of each pressure-reducing flow channel so that the flow channel extends between and connects the inlet and outlet of one of the plurality of inlets and outlets to form an emitter for reducing the pressure and flow of the pressurized fluid received at the inlet by the time the fluid is discharged through the plurality of outlets.

**17.** A method according to claim 16 wherein extruding the first tube layer comprises extruding a first tube layer having variable wall thickness, with a first thickened wall portion and a second thinner wall portion, and embossing comprises embossing the plurality of inlets and pressure-reducing flow channels into the first thickened wall portion of the first extruded tube layer.

**18.** A method according to claim 16 wherein embossing the plurality of inlets and pressure-reducing flow channels includes pressing the inlet opening into the outer surface of the first extruded tube layer to form an inlet that projects into the inner lumen of the first extruded tube layer so that the fluid received at the inlet comes from a region other than at a circumferential periphery of the lumen adjacent the inner surface of the first tube.

**19.** A method of manufacturing a drip line comprising: extruding an inner tube having inside and outside surfaces and defining an inner lumen through which fluid may flow;

applying a male die to the outside surface of the inner tube and a corresponding female die to the outside surface of the inner tube in alignment with the male die to form a raised wall extending from the outside surface of the inner tube; and

extruding an outer jacket over the inner tube to enclose at least a portion of the raised wall to form an emitter having an inlet open to the inner lumen of the tube and an outlet opening through the outer jacket, with the flow passage extending between the inlet and outlet.

\* \* \* \* \*