



US 20050208239A1

(19) **United States**

(12) **Patent Application Publication**
Nielsen et al.

(10) **Pub. No.: US 2005/0208239 A1**

(43) **Pub. Date: Sep. 22, 2005**

(54) **FLEXIBLE ARTICLE COMPRISING POCKET**

(75) Inventors: **Steven M. Nielsen**, Hastings, MN (US);
David G. Schueler, Forest Lake, MN (US); **John W. Frank**, Cottage Grove, MN (US)

Correspondence Address:
3M INNOVATIVE PROPERTIES COMPANY
PO BOX 33427
ST. PAUL, MN 55133-3427 (US)

(73) Assignee: **3M Innovative Properties Company**

(21) Appl. No.: **10/804,867**

(22) Filed: **Mar. 18, 2004**

Publication Classification

(51) **Int. Cl.⁷** **B65D 1/00**
(52) **U.S. Cl.** **428/34.1; 428/192**

(57) **ABSTRACT**

The invention relates to a flexible article such as a roll-up sign comprising a pocket, such pocket suitable for receipt of a support.

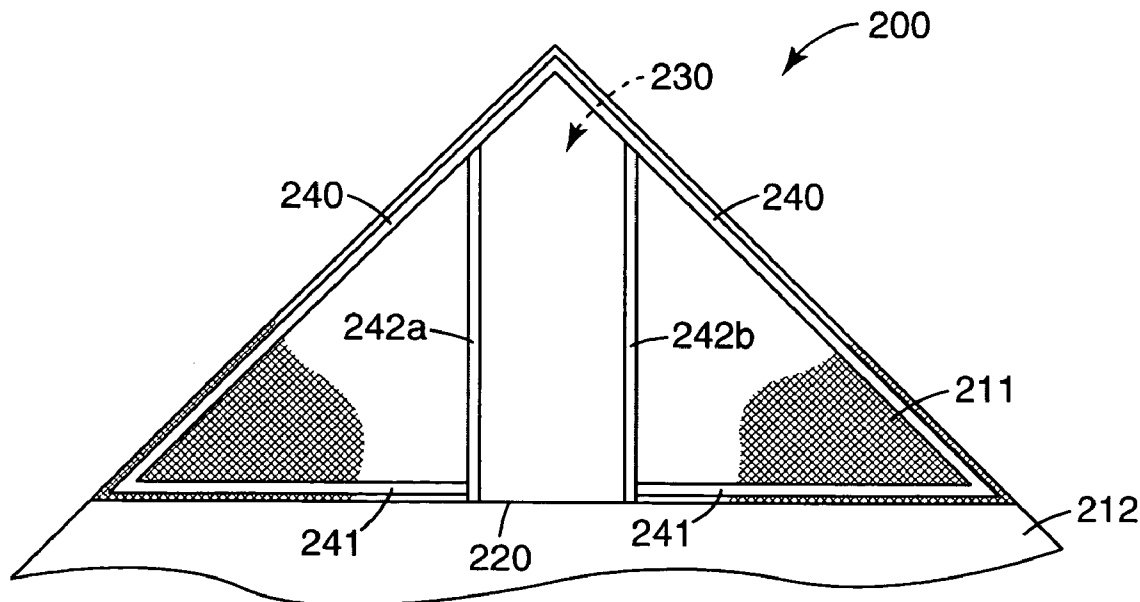

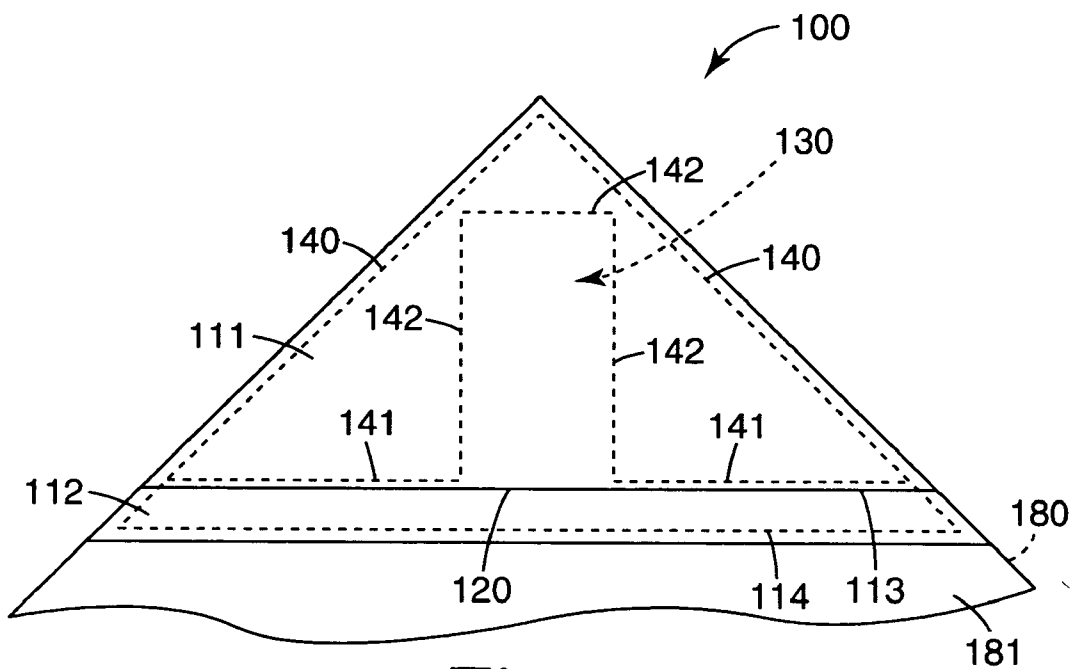

Fig. 1
PRIOR ART

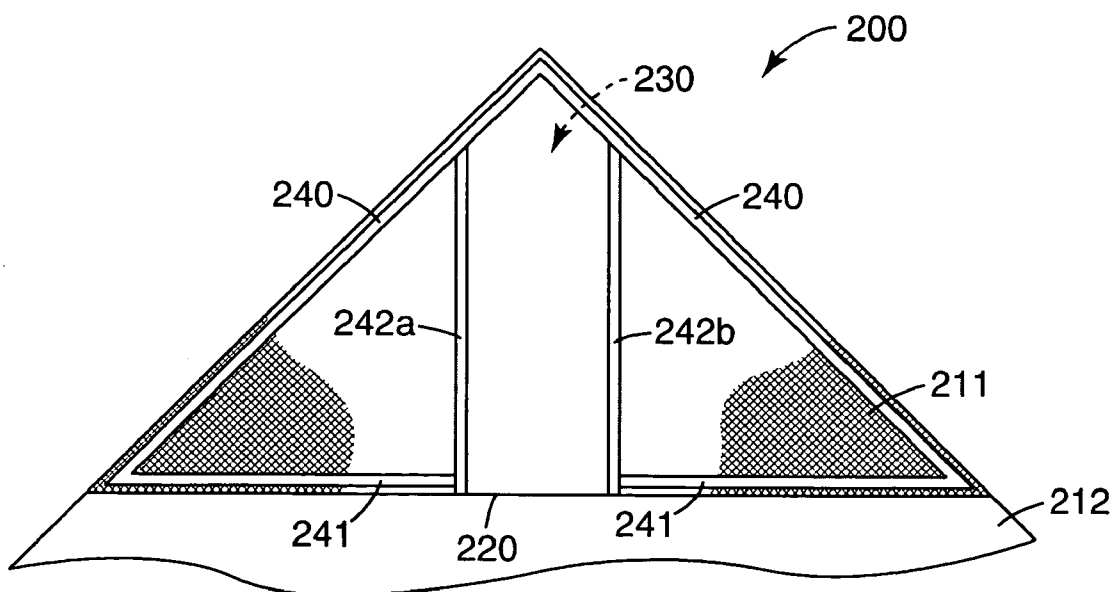

Fig. 2

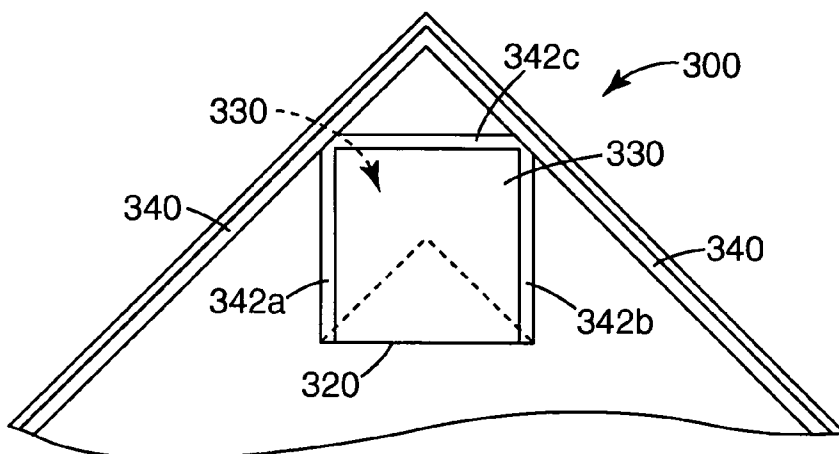

Fig. 3

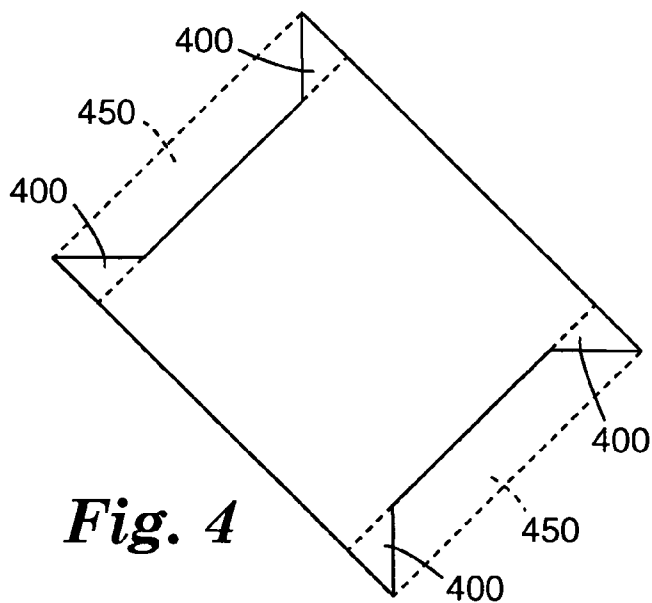

Fig. 4

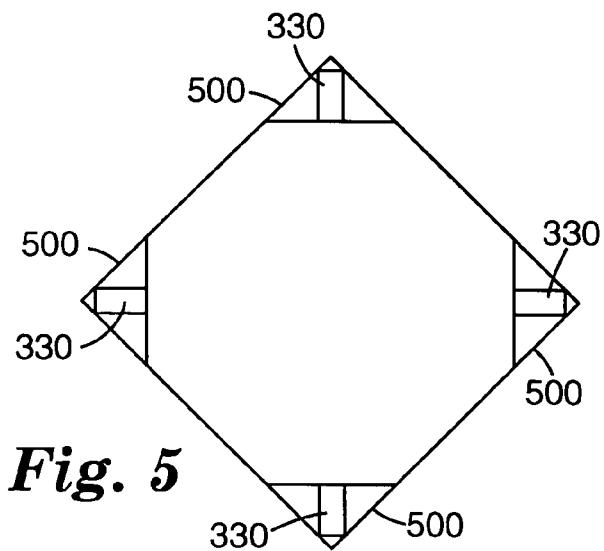

Fig. 5

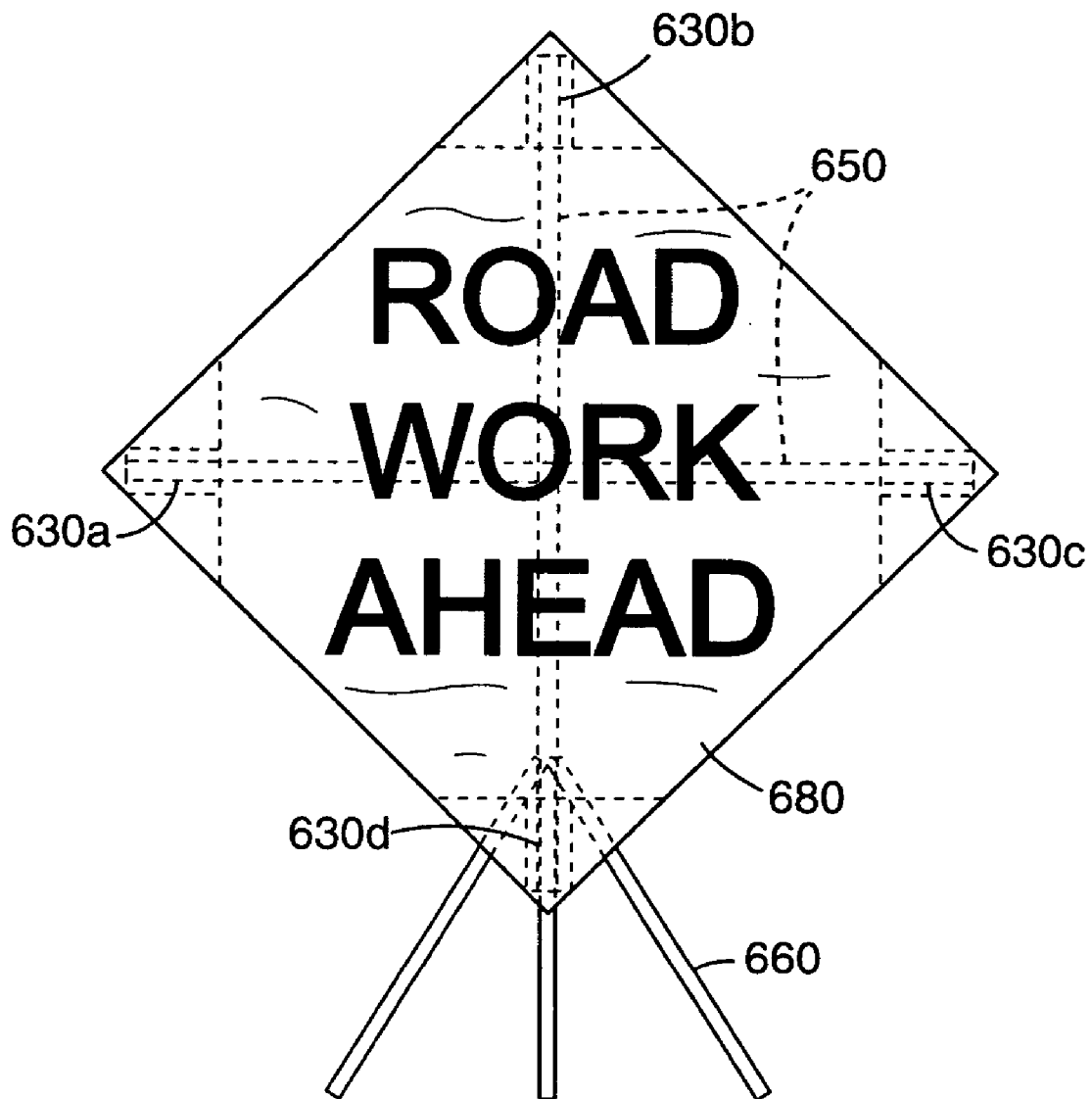

Fig. 6

FLEXIBLE ARTICLE COMPRISING POCKET

FIELD OF THE INVENTION

[0001] The invention relates to a flexible article such as a roll-up sign comprising a pocket, such pocket suitable for receipt of a support.

BACKGROUND OF THE INVENTION

[0002] Flexible, temporary highway signs for advance warning to a motorist of an approaching unsafe driving area or construction site are known (See for example U.S. Pat. Nos. 4,980,984 and 6,652,954.) Such signs are portable and can be folded or rolled up for transport and storage. During use, the signs are typically attached to a collapsible supporting apparatus (e.g. reinforcing frame) to allow the sign to be displayed along a roadway.

[0003] As described in U.S. Pat. No. 5,446,984; the reinforcing frame members may be removably secured to the flexible sign by means of "corner" pockets that are either "soft" pockets sewed on the sign itself or molded plastic members defining a socket and secured to the sign for removably securing the ends of the frame members. One such molded plastic socket is disclosed in U.S. Pat. No. 4,426,800 granted on Jan. 24, 1984. Alternative mounting members for use with flexible signs are described in U.S. Pat. Nos. 4,426,800; 4,490,934 and 5,446,984.

[0004] One example of a prior art flexible sign is commercially available from Korman Signs Inc., Richmond, Va. A plan view of the non-viewing surface of a corner portion of such prior art roll-up sign 100 is illustrated in FIG. 1. The corner portion consists of a first layer 111 and a second layer 112, each layer consisting of a piece of a square-shape fluorescent orange mesh that has been folded onto itself along folds 113 and 114. The first layer 111 has been sewn to the second layer 112 along seams 141 and 142 resulting in a pocket 130 having a single opening 120 and an enclosure defined by stitched seams 142. The pocket assembly has been stitched to fluorescent orange retroreflective sheeting at seams 140 and 114. The non-viewing surface 181 of the sheeting consists of a backing layer; whereas the viewing surface 180 consists of topfilm bonded to an underlying cube corner retroreflective layer. A black colored sign legend is present on the exposed surface of the topfilm.

[0005] Although various roll-up signs are known, industry would find advantage in a roll-up sign that can be manufactured with improved efficiency.

SUMMARY OF THE INVENTION

[0006] The present invention discloses a flexible article having at least one pocket. The article is sufficiently flexible such that the article can be wrapped around a mandrel having a diameter of about 1/2" (1.3 cm) at 25° C. without visible cracking. The pocket is comprised of at least one flexible substrate. The pocket is defined by a pair of unstitched bonds that form an enclosure having at least one opening there between. The peripheral bonds may be melt-bonded or adhesive bonded. During use, the pocket receives a support.

[0007] In one aspect, the article is a (e.g. traffic) sign. In another aspect, the article comprises a viewing surface wherein at least a portion thereof is retroreflective. Such articles typically comprise indicia and/or graphics on a planar viewing surface. Polygonal and quadrilateral shaped planar viewing surfaces are common. The pockets are typi-

cally present on opposing ends of the article such as at opposing corner portions. The pockets are preferably present on the non-viewing surface.

[0008] Also described are methods of making articles such as sign. In one aspect, the method comprises providing a flexible sheet; folding a portion of the flexible sheet onto itself; and bonding the folded flexible sheet such that at least one pocket is formed. In another aspect, the method comprises providing a planar article and bonding at least one separate piece of a flexible substrate such that at least one pocket is formed.

[0009] Particularly for traffic signs, the viewing surface preferably comprises retroreflective sheeting. The non-viewing surface may comprise a backing. In order to form a pocket integral with the backing, it is preferred that the backing extends beyond the retroreflective layer in at least one dimension such that the pockets are formed from the extended portions of the backing. Alternatively, the pockets may comprise other flexible substrates such as fabric, optionally comprising a polymeric coating; and/or a polymeric film.

BRIEF DESCRIPTION OF THE DRAWINGS

[0010] FIG. 1 illustrates a plan view of one example of a prior art flexible sign 100.

[0011] FIG. 2 illustrates a plan view of the non-viewing surface of a portion of one embodiment of the invention.

[0012] FIG. 3 illustrates a plan view of the non-viewing surface of a portion of another embodiment of the invention.

[0013] FIG. 4 illustrates an example of a shape of a substrate for making a sign having corner pockets.

[0014] FIG. 5 depicts the non-viewing surface of a sign prepared from the exemplary shape of FIG. 4.

[0015] FIG. 6 depicts a plan view of the viewing surface of a roll-up sign further comprising a support.

DETAILED DESCRIPTION OF THE INVENTION

[0016] The present invention relates to a flexible article suitable for use as a sign comprising at least one pocket. As used herein, pocket refers to an enclosure having at least one opening. Preferably, the pocket includes a single opening and the entire perimeter of the pocket with the exception of the opening comprises unstitched peripheral bonds. As used herein, "unstitched bonds" refers to bonds that are not sewn. Suitable means of preparing unstitched bonds includes melt-bonding as well as adhesive bonding. Such bonding techniques are advantageously less labor intensive than sewing. Although combinations of stitched and unstitched bonds may be employed, the greatest benefit is typically obtained when the totality of the bonds of the pocket member and finished article are not sewn.

[0017] With reference to FIG. 6, during use, the pockets 630a, 630b, 630c, and 630d further include a (e.g. removable) support, such as a collapsible crossbar 650 and optional stand 660. The support generally provides sufficient rigidity to the viewing surface 680 of the article (e.g. sign). Three-dimensional supports (e.g. cones, barrels, etc.) may be employed as well.

[0018] The sign is suitable for advertising, display and/or traffic safety uses including (e.g. roll-up) signs, flags, banners, and the like. Such articles typically include indicia such as words and/or symbols and/or graphics viewable from the viewing surface. Although the pockets may alternatively be present on the viewing surface provided that the article remains suitable for its intended end-use, the pockets are preferably present on the non-viewing surface of the article.

[0019] In the case of roll-up signs for example, the viewing surface of the article (e.g. sign) during use is substantially planar. The viewing surface of the (e.g. sign) article can be in any shape with polygons (e.g. octagons), quadrilaterals, and circular shapes being most common particularly for traffic signs. Although indicia and/or graphics may optically be provided on both sides, the article will be described in further detail with reference to a roll-up sign comprising a single quadrilateral planar viewing surface.

[0020] FIG. 2 depicts a plan view of the non-viewing surface of a corner portion of one embodiment of the invention. Pocket 230 of the (e.g. sign) article 200 has an opening 220 and an enclosure defined by unstitched bonds 242. The pocket comprises a pair of substantially parallel bonds 242a and 242b with the opening there between. In the case of pocket 230, the remainder of the perimeter is bonded at unstitched bonds 240.

[0021] FIG. 3 depicts a plan view of the non-viewing surface of a corner portion of another embodiment of the invention. Pocket 330 of (e.g. sign) article 300 has an opening 320 and an enclosure defined by unstitched bonds 342. The pocket comprises a pair of substantially parallel bonds (e.g. 342a and 342b) with the opening there between. In the case of pocket 301, the remainder of the perimeter is bonded at unstitched bond 342c. The peripheral edges of the corner sign also include unstitched bonds 340.

[0022] The pocket substrate may comprise the same or a different flexible substrate than the viewing surface (e.g. sign) substrate. The articles of the invention may be prepared from a single substrate wherein the pockets are formed by folding the (e.g. non-viewing surface) of the sign substrate onto itself and forming unstitched bonds such that one or more (e.g. opposing) pockets are formed. For example, as depicted in FIG. 4 triangular shaped flaps 400 may extend from each corner. The flaps can then be folded onto the backing layer and bonded, as depicted in FIG. 5. As another embodiment, rectangular shaped flaps (i.e. 450 of FIG. 4) may be employed. In doing so, the pockets are integral with the sign substrate. Conveniently, the pocket enclosure may consist of the backing material on both interior surfaces of the enclosure thus formed. Alternatively, however, a non-integral separate pocket may be formed with a separate portion of a pocket substrate bonded to a portion of the (e.g. sign) article. For example with reference to FIG. 2, the article may include retroreflective sheeting 212 as the sign substrate and a flexible polymeric mesh 211 as the pocket substrate.

[0023] Although the illustrated pockets include a pair of substantially parallel bonds with a single opening there between, in an alternative embodiment the pair of bonds may be angled (e.g. V-shaped) wherein the pair of bonds meet at one end. In yet another embodiment, the pocket may have a pair of (e.g. opposing) openings. Such bond designs are surmised to be novel for at least roll-up signs with stitched seams as sell.

[0024] The pattern and dimensions of the unstitched bonded may vary provided that sufficient bond strength is obtained. It is preferred that the unstitched bond is of sufficient strength such that it cannot be delaminated by hand without tearing the (e.g. pocket or backing film) substrate. Further, the bond strength of the unstitched bond is typically characterized by a 180 degree peel of at least about 1 lbf/linear inch bond length (1.8 Newtons/cm), and more preferably at least about 2 lbf/linear inch bond length (3.5 Newtons). The width of the unstitched bond may vary for example from about 1 mm to about 10 mm. The unstitched bonds may include multiple bonds (e.g. thermal welds of 0.2 mm to 3 mm each) with optional unbonded portions between discreet bonds. Alternatively, the multiple bonds may result in a continuous bond width. Although the unstitched bonds depicted in the illustrations have a linear pattern, other bond patterns such as zig-zag and scallop patterns may also be employed. In order to reduce tearing tendencies at the intersections between bonds (e.g. the intersection of 241 and 242), it is preferred that the intersections are rounded, having a radius of curvature rather than the intersections forming an angle. In order to reinforce the strength of the pocket, the pocket substrate may comprise multiple layers. For example, the pocket substrate may be folded onto itself such that the fold aligns with opening 320 of FIG. 3 with the excess pocket material preferably tucked within the enclosure. In a similar manner, each of the unstitched bonds may include folded pocket substrate. Alternatively or in addition thereto, the entire pocket member may include a double-ply of pocket substrate with the fold line along unstitched bond 241 of FIG. 2 for example.

[0025] Various techniques of forming unstitched bonds are known. The bonding technique for forming the unstitched bonds is chosen based on the substrate(s) utilized. A preferred technique is melt-bonding such as thermal welding, heat lamination, high frequency welding (e.g., radio frequency welding and ultrasonic welding), and the like. Whereas melt-bonding is suitable for a variety of polymeric (e.g. thermoplastic) substrates, adhesive bonding can be used for bonding non-thermoplastic pocket material such as fabrics based on natural fibers (canvas). Combinations of melt-bonding and adhesive bonding may also be employed.

[0026] In thermal welding; the substrates (e.g. sign substrate and pocket substrate) are passed between a nip roller and an embossing thermal roller applying a suitable pressure to the components over a raised ridge embossing pattern carried on the surface of the embossing roller. The counterforce nip roller is preferably a sufficiently hard rubber smooth surfaced roller, for example an 85 Shore A durometer roller. The embossing roller is patterned to exert pressure into the material being welded only at the point of the raised ridges. Both the embossing roller and the hard durometer roller are heated to suitable temperatures depending upon the composition of polymers used. The embossing pattern may be of several suitable patterns such a chain link pattern. Alternatively, a platen press may be used to form thermal welds.

[0027] A preferred melt-bonding technique includes radio frequency (RF) energy. The frequency of the radio frequency energy and the field strength are variable by an operator and chosen for suitability dependent upon the polymeric components of the substrate(s) being bonded. The choice depends on such factors as the individual polymeric

dielectric loss factors, dielectric constants, melting temperatures, and layer thickness. The radio frequency energy is delivered through antennas mounted within appropriate platens that are pressed onto the appropriate surfaces of the substrate(s) applying an appropriate amount of pressure and an appropriate duration of radio frequency energy. Reference is made to U.S. Pat. No. 5,962,108, incorporated herein by reference.

[0028] In order to improve the efficacy of the melt-bond formed one or more tie layers (e.g. adhesive) can be employed on the surfaces to be bonded. The tie layer is typically a thermoplastic polymer having a lower melting point at least one of the surface being bonded. The tie layer may be a single polymer, a single phase or multiphase blend of polymers, or may include multiple layers of compatible polymers to accomplish the bonding of the retroreflective layer to the tear resistant film. Exemplary polymers suitable for use as the tie layer include polyurethane; alkylene/alkyl acrylate copolymers such as ethylene methyl acrylate copolymer, ethylene N-butyl acrylate copolymer, ethylene ethyl acrylate copolymer; ethylene vinyl acetate copolymer; ethylene acrylic acid copolymer, polymerically plasticized polyvinyl chloride (PVC); and polyurethane primed ethylene acrylic acid copolymer as well as acrylate-based pressure sensitive adhesives. Blends of such materials may also be used if desired.

[0029] A wide variety of hot melt, water-based, and solvent-based adhesive compositions may be utilized as are known in the art. Suitable adhesives for the bonding of the non-viewing surface of retroreflective sheeting include for example various adhesives commercially available from 3M Company, St. Paul, Minn., such as acrylic foam adhesive tape having the trade designation, "3M VHB Acrylic Foam Tape 4979F Black"; solvent-base adhesive having the trade designation "3M Pronto Instant Adhesive CA40H", and a two part adhesive system having the trade designation "3M Scotch-Weld Acrylic Adhesive DP805".

[0030] The sign substrate(s) and pocket substrate(s) employed in the articles of the invention are "flexible". As used herein "flexible", refers to the ability to wrap the substrate, laminate or article by hand around a mandrel having a diameter of about 1/2" (1.3 cm) at 25° C. without visible cracking. Preferably, the article is sufficiently flexible such that this test can be conducted at lower temperatures including 0° C. More preferably, the article is sufficiently flexible such that it can be wrapped by hand around a mandrel having a diameter of about 1/4" (6 mm) at each of these temperatures (25° C., 0° C. and -29° C.) without visible cracking. The finished article is also flexible.

[0031] Various flexible substrates are known. The flexible substrate may be reflective, retroreflective or non-reflective. The flexible substrate may be a laminate comprising two or more discreet layers. The flexible substrate and in particular the sign substrate may further comprise colorants (e.g. pigments and/or dyes), ultraviolet light absorbers, light stabilizers, free radical scavengers, antioxidants, processing aids such as antiblocking agents, releasing agents, slip agents, lubricants, and other additives. The thickness of the flexible substrate typically ranges from about 1 mil (e.g. 2 mils, 3 mils) to about 100 mils. Preferably, the thickness of the flexible substrate is less than 25 mils and more preferably ranges from about 5 mils to 15 mils.

[0032] The flexible substrate may comprise a fabric. The fabric may be woven (e.g. mesh), knit, or non-woven. Polyester, nylon, polyvinyl chloride as well as natural fibers such as cotton may be employed including blends of such fibers. A preferred fabric that is particularly amenable to melt-bonding is a fabric having a thermoplastic coating such as a polyvinyl chloride coating.

[0033] Alternatively, the flexible substrate may be a flexible polymeric sheet or film. The sheet or film may be for example an acrylic-containing film, a poly(vinyl chloride)-containing film, a poly(vinyl fluoride)-containing film, a urethane-containing film, a melamine-containing film, a polyvinyl butyral-containing film, a polyolefin-containing film, a polyester-containing film or a polycarbonate-containing film. The flexible substrate may be a multilayer film or laminate as well.

[0034] In preferred embodiments, wherein the article is useful for traffic safety uses, flexible retroreflective sheeting is employed. In such embodiments the surface of the article that is viewed by an observer (i.e. the viewing surface) is retroreflective. The retroreflective viewing surface of the article may further comprise transparent protective layers such as a topfilm (e.g. tear resistant film such as described in U.S. Pat. No. 6,652,954) or coatings disposed between the retroreflective surface of the sheeting and the observer.

[0035] The two most common types of retroreflective sheeting suitable for use are microsphere-based sheeting and cube corner-based sheeting. Microsphere sheeting, sometimes referred to as "beaded sheeting," is well known to the art and includes a multitude of microspheres typically at least partially embedded in a binder layer, and associated specular or diffuse reflecting materials (such as metallic vapor or sputter coatings, metal flakes, or pigment particles). Illustrative examples of microsphere-based sheeting are disclosed in U.S. Pat. No. 4,025,159 (McGrath); U.S. Pat. No. 4,983,436 (Bailey); U.S. Pat. No. 5,064,272 (Bailey); U.S. Pat. No. 5,066,098 (Kult); U.S. Pat. No. 5,069,964 (Tolliver); and U.S. Pat. No. 5,262,225 (Wilson).

[0036] Cube corner sheeting, sometimes referred to as prismatic, microprismatic, or triple mirror reflector sheetings, typically includes a multitude of cube corner elements to retroreflect incident light. Cube corner retroreflectors typically include a sheet having a generally planar front surface and an array of cube corner elements protruding from the back surface. Cube corner reflecting elements include generally trihedral structures which have three approximately mutually perpendicular lateral faces meeting in a single corner—a cube corner. In use, the retroreflector is arranged with the front surface disposed generally toward the anticipated location of intended observers and the light source. Light incident on the front surface enters the sheet and passes through the body of the sheet to be totally internally reflected by the faces of the elements, so as to exit the front surface—in a direction substantially toward the light source. The light rays are typically reflected at the lateral faces due to total internal reflection, or by reflective coatings, as previously described, on the back side of the lateral faces. Preferred polymers for forming the array of cube corner elements in retroreflective embodiments of the invention include poly(carbonate), poly(methylmethacrylate), poly(ethyleneterephthalate), aliphatic polyurethanes and cross-linked acrylates such as multifunctional acrylates or

epoxies and acrylated urethanes blended with mono- and multifunctional monomers. These polymers are preferred for one or more of the following reasons: thermal stability, environmental stability, clarity, excellent release from the tooling or mold, and capability of receiving a reflective coating. Illustrative examples of flexible cube corner-based retroreflective sheeting such sheeting are disclosed in U.S. Pat. No. 5,138,488 (Szczech); U.S. Pat. No. 5,387,458 (Pavelka); U.S. Pat. No. 5,450,235 (Smith); U.S. Pat. No. 5,605,761 (Burns); U.S. Pat. No. 5,614,286 (Bacon); U.S. Pat. No. 5,066,098 (Kult et al.); and U.S. Pat. No. 4,896,943 (Tolliver et al.).

[0037] The coefficient of retroreflection varies depending on the desired properties of the finished article. In general, however, the retroreflective (e.g. signage) article typically has a coefficient of retroreflection ranging from about 5 candelas per lux, for colored retroreflective layers, to about 1500 candelas per lux per square meter at 0.2 degree observation angle and -4 degree entrance angle, as measured according to ASTM E-810 test method for coefficient of retroreflection of retroreflective sheeting. The coefficient of retroreflection is preferably at least 10, more preferably at least 15, and even more preferably at least 20 candelas per lux per square meter. Typically traffic devices, have a coefficient of retroreflection of at least 100 candelas per lux per square meter and preferably at least 200 candelas per lux per square meter for fluorescent orange and at least about 550 candelas per lux for white. Preferably, the retroreflective article has a retroreflectivity under wet or rainy conditions of not less than 70% of its retroreflectivity under dry conditions. Further description of retroreflection and retroreflective sheeting is found in "Standard Specification for Retroreflective Sheeting for Traffic Control" ASTM D 4956-94 (November 1994).

[0038] A preferred retroreflective sheeting suitable for roll-up traffic signs include a retroreflective microstructured member; a sealing layer melt-bonded to the microstructured (e.g. cube corner retroreflective layer) member; and a backing member; such as described in U.S. Pat. No. 6,004,422 incorporated herein by reference. The backing member preferably includes a fibrous web comprising a plurality of multifilament strands and is melt-bonded to the sealing layer. Illustrative examples of polymers suitable for use in a sealing layer include polyurethanes, alkylene/alkyl acrylate copolymers such as ethylene/methyl acrylate copolymer, ethylene/N-butyl acrylate copolymer, ethylene/ethyl acrylate copolymer, ethylene/vinyl acetate copolymers, polymerically plasticized PVC, and polyurethane primed ethylene/acrylic acid copolymer. Blends of such materials may be used if desired. Typically, the sealing layer is melt-bonded to the microstructured member in a network of interconnecting bond lines to form an array of sealed cells containing a plurality of cube corner elements. As described in U.S. Pat. No. 4,025,159 (McGrath), such network of bonds and the body of the sealing layer provide hermetically sealed cells of retroreflective elements in which an air interface on the surfaces of the cube corner elements is maintained. In some embodiments, the microstructured surface may be metalized and the sealing layer may be melt-bonded to the metal surface substantially continuously or in discontinuous fashion. In addition, the sealing layer functions to bond the microstructured member to the backing member via melt-bonding, e.g., high frequency welding and/or patterned thermal welding.

[0039] In making the pockets of the invention, it is preferred that the backing layer, optionally yet preferably further comprising the sealing layer extends beyond the peripheral boundaries of the retroreflective layer. With reference to FIG. 4, flaps 400 may comprise this backing layer in the absence of the retroreflective layer. Accordingly, upon folding and bonding the flaps as depicted in FIG. 5, one edge of the pocket member 500 includes a bonded fold of the backing. Optionally, a pair of rectangular shaped flaps (e.g. 450 of FIG. 4) may be employed. These constructions are surmised to be particularly advantageous since the pocket can be formed during the same manufacturing step as bonding the backing layer to the non-viewing surface of the retroreflective (e.g. microstructured member) as previously described.

[0040] Objects and advantages of this invention are further illustrated by the following examples, but the particular materials and amounts thereof recited in these examples, as well as other conditions and details, should not be construed to unduly limit this invention.

EXAMPLES

[0041] For each of Examples 1-7 the non-viewing surface of retroreflective sheeting was bonded to a pocket substrate by means of radio frequency welding using equipment commercially available from USF Machine Systems, Inc. under the trade designation "FIAB 3005LF". The welding conditions utilized were as follows:

[0042] Power Setting—10

[0043] Pressure—0.6 bar

[0044] Time—8 seconds

[0045] Welding Tool—4 inches in length with $2\frac{1}{16}$ inch (5.24 cm) wide bars spaced $\frac{1}{16}$ inch (1.6 mm) apart

[0046] various retroreflective sheeting as the sign substrate and various pocket substrates as further described in each example.

[0047] Unstitched bonds were formed such that the corner had the same pattern as depicted in FIG. 2. Each of bonds 240 were 9 inches (23 cm). The opening 220 had a dimension of $2\frac{1}{2}$ inches (6.4 cm). Each of bonds 241 had a dimension of 4 inches (10.2 cm).

[0048] For each of the examples a corner portion was prepared using a triangular-shaped piece of one of two types of retroreflective sheeting commercially available from 3M Company, St. Paul, Minn. under the trade designations "3M Fluorescent Rollup Sign Sheeting Series RS30" ("RS34") and "3M Diamond Grade Fluorescent Rollup Sign Sheeting Series RS20" ("RS24"). The non-viewing surface of the sheeting was bonded to triangular-shaped pieces of various pocket materials as described in each of the examples.

Example 1

[0049] Retroreflective Sheeting: RS34

[0050] Pocket Substrate: A triangular piece of 12 ounce reinforced plasticized vinyl backing film commercially available from Herculite Incorporated, Emigsville, Pa., under the trade designation "Architent".

Example 2

[0051] Retroreflective Sheeting: RS24

[0052] Pocket Substrate: A triangular piece of the Architent film of Example 1.

Example 3

[0053] Retroreflective Sheeting: The topfilm and cube corner retroreflective layer from RS34

[0054] Backing/Pocket Substrate: The Architent film of Example 1 was cut in the shape of a diamond, folded into a triangle such that the fold was aligned with reference numeral 241 and then welded to the non-viewing surface of the retroreflective layer.

Example 4

[0055] Retroreflective Sheeting: RS34

[0056] Pocket Substrate—About 1 cm of the vinyl was folded such that the fold was aligned with reference numeral 241 of FIG. 2 and then welded to the non-viewing surface of the retroreflective layer.

Example 5

[0057] Example 5 was the same as Example 4 except that the RS20 retroreflective sheeting was utilized.

Example 6

[0058] Retroreflective Sheeting: RS34

[0059] Pocket Substrate: A triangular piece of vinyl coated scrim commercially available from Snyder Manufacturing Inc., Dover, Ohio under the trade designation “PCS 899K”.

Example 7

[0060] Example 5 was the same as Example 6 except that the RS20 retroreflective sheeting was utilized.

[0061] The bond strength of each of Examples 1-7 was inspect and evaluated by hand. Since the retroreflective sheeting could not be separated by hand from the pocket substrate without tearing the pocket substrate, the bond strength was determined to be suitable.

[0062] The complete disclosures of the patents, patent documents, and publications cited herein are incorporated by reference in their entirety as if each were individually incorporated. Various modifications and alterations to this invention will become apparent to those skilled in the art without departing from the scope and spirit of this invention. It should be understood that this invention is-not intended to be unduly limited by the illustrative embodiments and examples set forth herein and that such examples and embodiments are presented by way of example only with the scope of the invention intended to be limited only by the claims set forth herein as follows

What is claimed is:

1. A sign comprising at least one pocket wherein the pocket is comprised of a flexible substrate and defined by a pair of unstitched bonds that form an enclosure having at least one opening there between.

2. The sign of claim 1 wherein the sign is flexible such that the sign can be wrapped around a mandrel having a diameter of about 1/2" (1.3 cm) at 25° C. without visible cracking.

3. The sign of claim 1 wherein at least a portion of the unstitched peripheral bonds are melt bonded.

4. The sign of claim 1 wherein at least a portion of the unstitched peripheral bonds are adhesive bonded.

5. The sign of claim 1 wherein the sign comprises a viewing surface and a non-viewing surface and the pocket is present on the non-viewing surface.

6. The sign of claim 5 wherein the viewing surface comprises retroreflective sheeting.

7. The sign of claim 5 wherein the non-viewing surface comprises a backing.

8. The sign of claim 7 wherein the flexible substrate of the pocket consists of the backing.

9. The sign of claim 1 wherein the flexible substrate is selected from fabric and polymeric film.

10. The sign of claim 9 wherein the fabric comprises a polymeric coating.

11. The sign of claim 1 wherein the sign is a quadrilateral having four corners.

12. The sign of claim 11 wherein pockets are present in the corners.

13. The sign of claim 1 wherein the article is free of stitched bonds.

14. The sign of claim 1 further comprising a support removably attached to the sign by means of the pocket.

15. A flexible article comprising a viewing surface wherein at least a portion thereof is retroreflective and at least one pocket comprised of a flexible substrate wherein the pocket is defined by a pair of unstitched bonds that form an enclosure having at least one opening there between.

16. The article of claim 16 wherein the article comprising a viewing surface comprising at least indicia or graphics.

17. A method of making a sign comprising:

providing a flexible sheet;

folding a portion of the flexible sheet onto itself; and

bonding the folded flexible sheet such that at least one pocket is formed.

18. The method of claim 17 wherein the flexible sheet comprises retroreflective sheeting comprising a viewing surface and a backing and the backing is folded onto itself.

19. The method of claim 17 wherein the bonding is selected from melt-bonding and adhesive bonding.

20. A method of making a sign comprising:

providing a sign substrate,

providing at least one piece of a flexible substrate; and

bonding the flexible substrate to the sign substrate such that at least one pocket is formed.

21. A flexible sign comprising at least one pocket comprised of a flexible substrate wherein the pocket is defined by a pair bonds that form an enclosure having two opposing openings there between.