



US00RE37126E

(19) **United States**
(12) **Reissued Patent**
Peng et al.

(10) **Patent Number:** **US RE37,126 E**
(45) **Date of Reissued Patent:** **Apr. 3, 2001**

(54) **MULTILEVEL CASCADE VOLTAGE SOURCE INVERTER WITH SEPERATE DC SOURCES**

5,424,627 6/1995 Clark et al. .
5,481,448 1/1996 Nakata et al. .
5,532,575 7/1996 Ainsworth et al. .
5,535,114 7/1996 Horie et al. .
5,644,483 * 7/1997 Peng et al. 363/37

(75) Inventors: **Fang Zheng Peng**, Knoxville, TN (US); **Jih-Sheng Lai**, Blacksburg, VA (US)

FOREIGN PATENT DOCUMENTS

76 12062 11/1977 (FR) .

(73) Assignee: **Lockheed Martin Energy Systems, Inc.**, Oak Ridge, TN (US)

OTHER PUBLICATIONS

(21) Appl. No.: **09/167,287**
(22) Filed: **Oct. 6, 1998**

“Control Strategy of Active Power Filters Using Multiple Voltage–Source PWM Converters,” by Hirofumi Akagi, Akira Nabae, & Satoshi Atoh, in *IEEE Transactions on Industry Applications*, vol. 1A–22, No. 3, May/June. 1986, pp. 460–465.

“Naturally Commutated Thyristor–Controlled High–Pulse VAR Compensator,” by J. Arrillaga, R.D. Brough, & R.M. Duke, in *IEEE Proceedings—Generation, Transmission & Distribution*, vol. 142, No. 2, Mar. 1995, pp. 219–224.

(List continued on next page.)

Related U.S. Patent Documents

Reissue of:

(64) Patent No.: **5,642,275**
Issued: **Jun. 24, 1997**
Appl. No.: **08/527,995**
Filed: **Sep. 14, 1995**

Primary Examiner—Matthew Nguyen

(74) *Attorney, Agent, or Firm*—Jones & Askew, LLP

U.S. Applications:

(63) Continuation of application No. 08/527,995, filed on Sep. 14, 1995, now Pat. No. 5,642,275.

(57)

ABSTRACT

(51) **Int. Cl.**⁷ **H02M 7/521**
(52) **U.S. Cl.** **363/137; 363/58**
(58) **Field of Search** 363/58, 59, 129, 363/132, 136, 137; 323/271, 282

A multilevel cascade voltage source inverter having separate DC sources is described herein. This inverter is applicable to high voltage, high power applications such as flexible AC transmission systems (FACTS) including static VAR generation (SVG), power line conditioning, series compensation, phase shifting and voltage balancing and fuel cell and photovoltaic utility interface systems. The M-level inverter consists of at least one phase wherein each phase has a plurality of full bridge inverters equipped with an independent DC source. This inverter develops a near sinusoidal approximation voltage waveform with only one switching per cycle as the number of levels, M, is increased. The inverter may have either single-phase or multi-phase embodiments connected in either wye or delta configurations.

(56) **References Cited**

U.S. PATENT DOCUMENTS

3,581,212 5/1971 McMurray .
3,867,643 2/1975 Baker et al. .
4,052,657 10/1977 Kleiner et al. .
4,052,658 10/1977 Hucker .
4,470,005 9/1984 Gyugyi .
4,571,535 2/1986 Gyugyi .
5,270,657 12/1993 Wirth et al. .
5,311,419 5/1994 Shires .
5,329,221 7/1994 Schauder .
5,345,375 9/1994 Mohan .

36 Claims, 10 Drawing Sheets

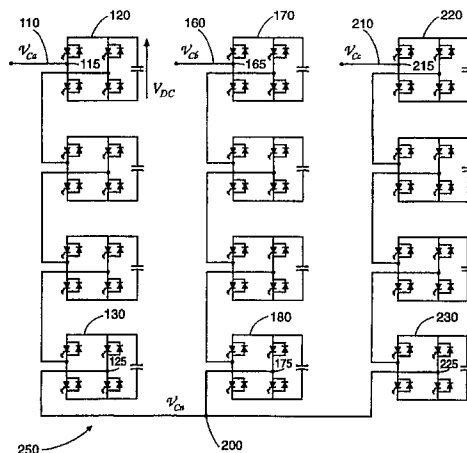

OTHER PUBLICATIONS

"A Novel Multilevel Structure for Voltage Source Inverter," by M. Carpita, S. Tenconi, & M. Fracchia in *EPE Firenze*, 1991, pp. 1-090 through 1-094.

"Modeling Analysis and Control of Static VAR Compensator Using Three-Level Inverter," by Guk C. Cho, Nam S. Choi, Chun T. Rim & Gyu H. Cho, in *Conference Record of the IEEE Industry Applications Society Annual Meeting*, Houston, Texas, Oct. 4-9, 1992, vol. 1, pp. 837-843.

"Modeling and Analysis of a Multilevel Voltage Source Inverter Applied as a Static VAR Compensator," by Nam S. Choi, Guk C. Cho, & Gyu H. Cho, in *International Journal of Electronics*, 1993, vol. 75, No. 5, 1015-1034.

"Modeling and Analysis of a Static VAR Compensator Using Multilevel Voltage Source Inverter," by Nam S. Choi, Guk C. Cho & Gyu H. Cho, in *Conference Record of the 1993 IEEE Industry Applications Conference*, 28th IAS Annual Meeting, Toronto, Canada Oct. 1993, pp. 901-908.

"Experimental Investigation of an Advanced Static VAR Compensator," by J.B. Ekanayake, N. Jenkins, & C.B. Cooper in *IEEE Proceedings—Generation, Transmission and Distribution*, vol. 142, No. 2, Mar. 1995, pp. 202-210.

"Active AC Power Filters," by L. Gyugyi & E.C. Strycula, in *IAS '76 Annual*, 19-C, pp. 529-535.

"Principles and Applications of Static Thyristor-Controlled Shunt Compensators," by L. Gyugyi, R.A. Otto, & T.H. Putman, in *IEEE Transactions on Power Apparatus and Systems*, vol. PAS-97, No. 5, Sep./Oct. 1978, pp. 1935-1945.

"Comparison of Multilevel Inverters for Static VAR Compensation," by Clark Hochgraf, Robert Lasseter, Deepak Divan, & T.A. Lipo, in *IEEE Doc. No. 0-7803-1993-1/94*, pp. 921-928.

"A New N-Level High Voltage Inversion System," by Young-Seok Kim, Beom-Seok Seo & Dong-Seok Hyun, in *IEEE Doc No 0-7803-0891-3/93*, pp. 1252-1258.

"High-Performance Current Control Techniques for Applications to Multilevel High-Power Voltage Source Inverters," by Mario Marchesoni, in *IEEE Transactions on Power Electronics*, vol. 7, No. 1, Jan. 1992, pp. 189-204.

"Advanced Static Compensation Using a Multilevel GTO Thyristor Inverter," by R.W. Menzies & Yiping Zhuang, in *IEEE Transactions on Power Delivery*, vol. 10, No. 2, Apr. 1995, pp. 732-738.

"Analysis and Design of a Three-Phase Current Source Solid-State V Ar Compensator," by Luis T. Moran, Phoivos D. Ziogas, & Geza Joos in *IEEE Transactions on Industry Applications*, vol. 25, No. 2, Mar./Apr. 1989, pp. 356-365.

"Development of a Large Static V Ar Generator Using Self-Commutated Inverters for Improving Power System Stability," by Shosuke Mori, Masatoshi Takeda et al. in *IEEE Transactions on Power Systems*, vol. 8, No. 1, Feb. 1993, pp. 371-377.

"A Study of Active Power Filters Using Quad-Series Voltage-Source PWM Converters for Harmonic Compensation," by Fang-Zhang Peng, Hirofumi Akagi & Akira Nabae in *IEEE Transactions on Power Electronics*, vol. 5, No. 1, Jan. 1990, pp. 9-15.

"A Static VAR Generator Using a Staircase Waveform Multilevel Voltage-Source Converter," by Fang Zheng Peng & Jih-Sheng Lai in *Power Quality*, Sep. 1994 Proceedings, pp. 58-66.

"An Active Power Quality Conditioner for Reactive Power and Harmonics Compensation," by N.R. Raju, S.S. Venkata, R.A. Kagalwala, & V. V. Sastry, in an unidentified publication, on Dec. 6, 1995, pp. 209-214.

"Development of a ± 100 MVAR Static Condenser for Voltage Control of Transmission Systems," by C. Schauder, M. Gernhardt, E. Stacey, T. Lemak, L. Gyugyi, T.W. Cease & A. Edris, a paper presented at the IEEE/PES 1994 Summer Meeting, San Francisco, California, Jul. 24-28, 1994.

"Which is Better at a High Power Reactive Power Compensation System: High PWM Frequency or Multiple Connections?" by Nagataka Seki & Hiroshi Uchino, *IEEE Doc No. 0-7803-1993-1/94*, pp. 946-953.

"Analysis of GTO-Based Static VAR Compensators," by D.R. Trainer, S.B. Tennakoon, & R.E. Morrison in *IEEE Proceedings—Electric Power Applications*, vol. 141, No. 6, Nov. 1994, pp. 293-302.

"Simulation and Experimental Study of a Reactively Loaded PWM Converter as a Fast Source of Reactive Power," by Jacobus D. Van Wyk, Dirk Adrian Marshall & Septimus Boshoff in *IEEE Transactions on Industry Applications*, vol. 1A-22, No. 6, Nov./Dec. 1986, pp. 1082-1090.

"Force-Commutated Reactive-Power Compensator," by Loren H. Walker, in *IEEE Transactions on Industry Applications*, vol. 1A-22, No. 6, Nov./Dec. 1986, pp. 1091-1104.

"Controlling a Back-to-Back DC Link to Operate as a Phase Shift Transformer," by D.A. Woodford & R.W. Menzies, paper 14-202 in *CIGRE* 1994.

"A Comparison of Different Circuit Configurations for an Advanced Static VAR Compensator (ASVC)," by D. Wuest, H. Stemmler & G. Scheuer in *IEEE Power Electronics Specialists Conference*, Toledo, Spain, Jun. 29-Jul. 3, 1992 (PESC '92 Record) vol. 1, pp. 521-529.

Japanese article "Static Type Reactive Power Generator (SVG) of Shinbiwajima Transformer Station," by Shigeru Nakajima and Ichibeï Komori in *Tetsudo to Denki Gijutsu* ("Railroad and Electric Technology") vol. 5 No. 6 (1994) pp. 41-45 (w/translation).

* cited by examiner

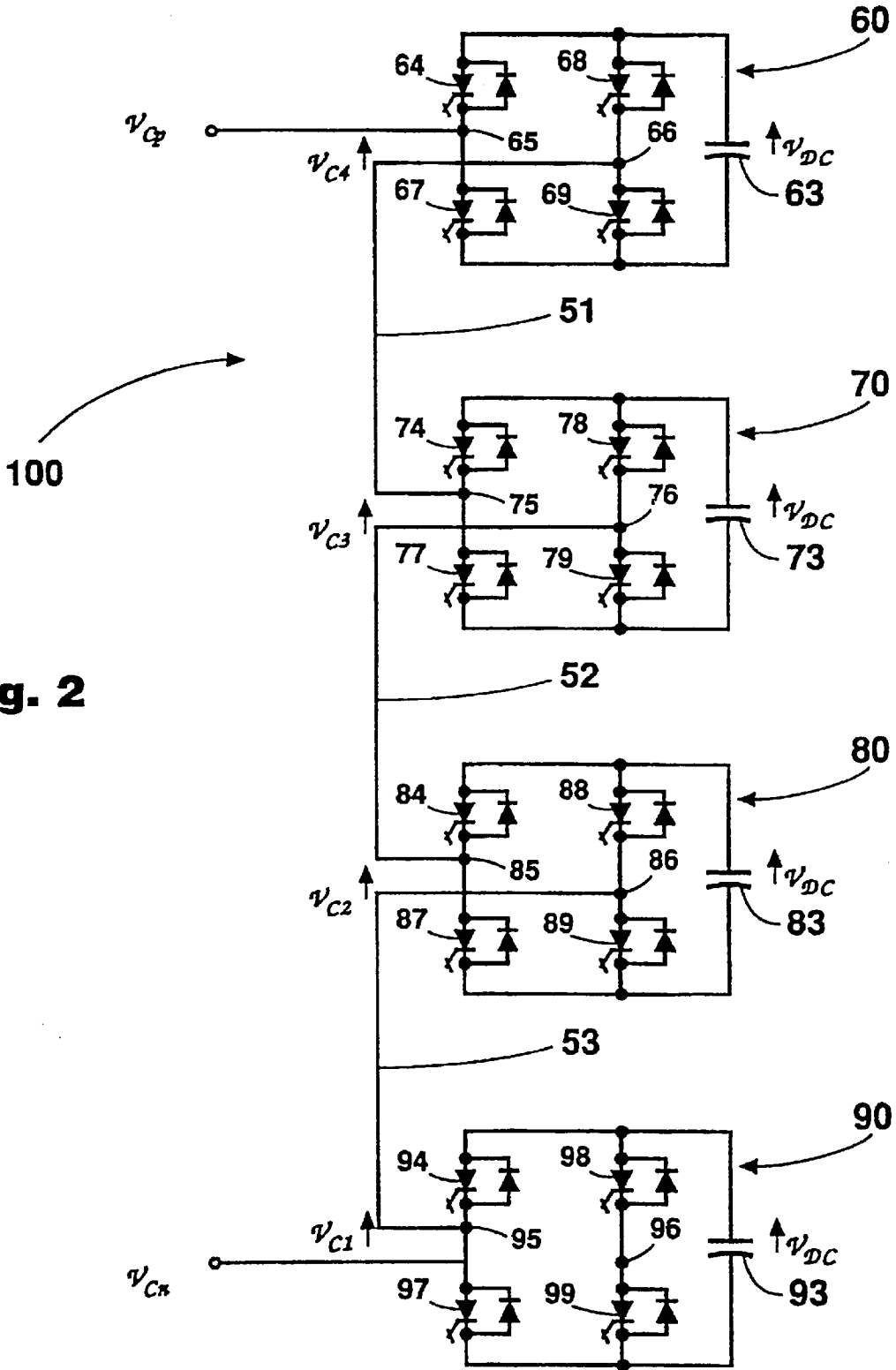

Fig. 2

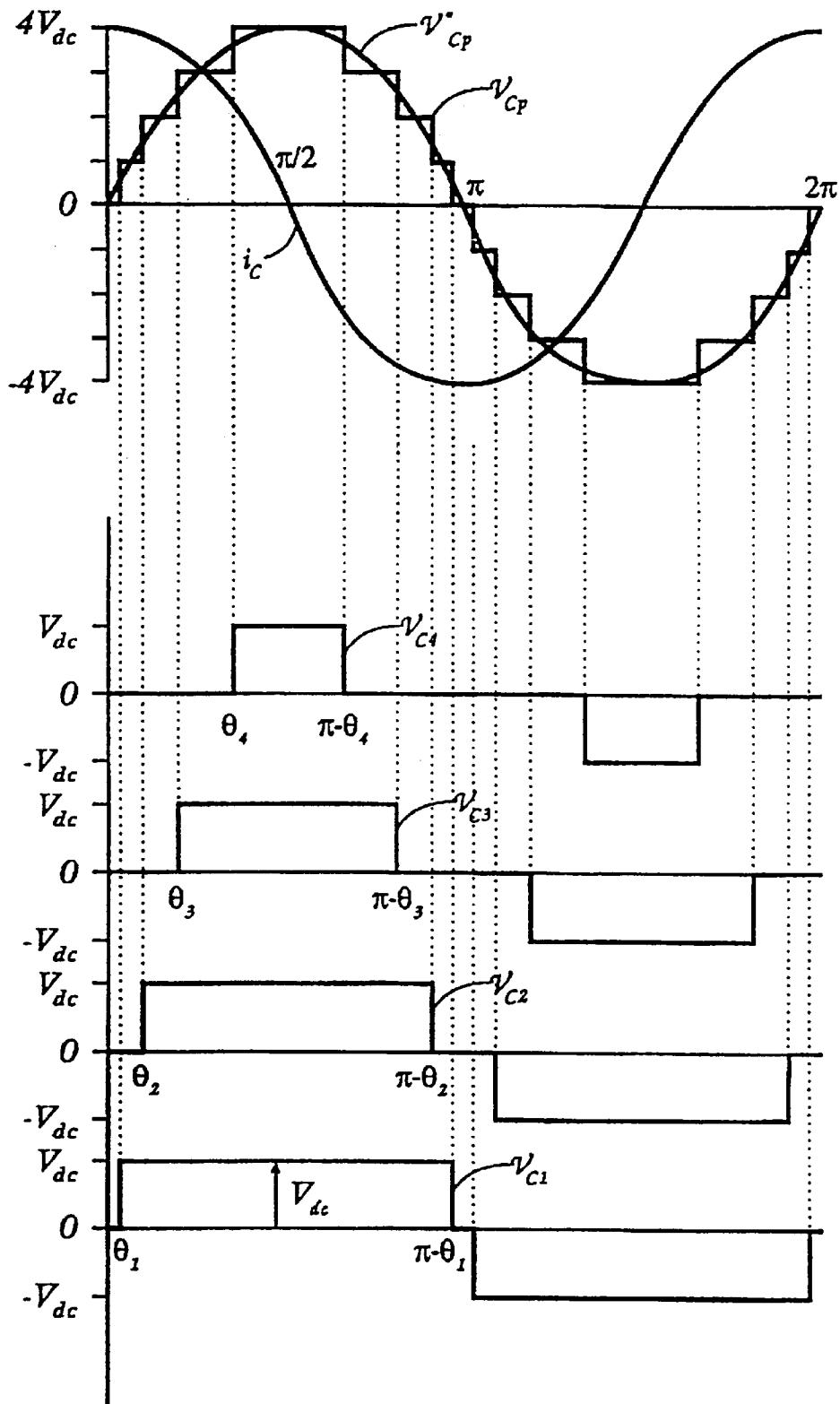

Fig. 3

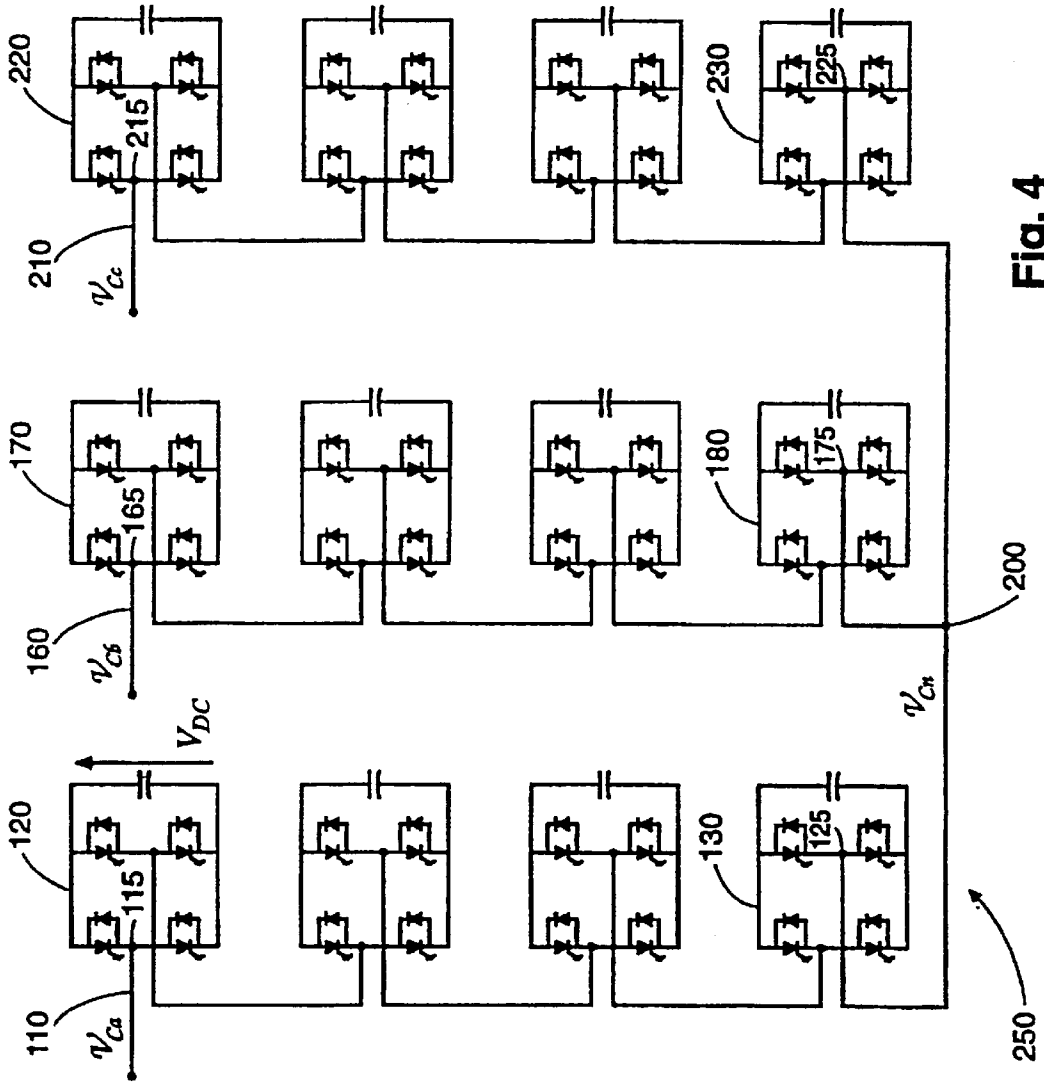

Fig. 4

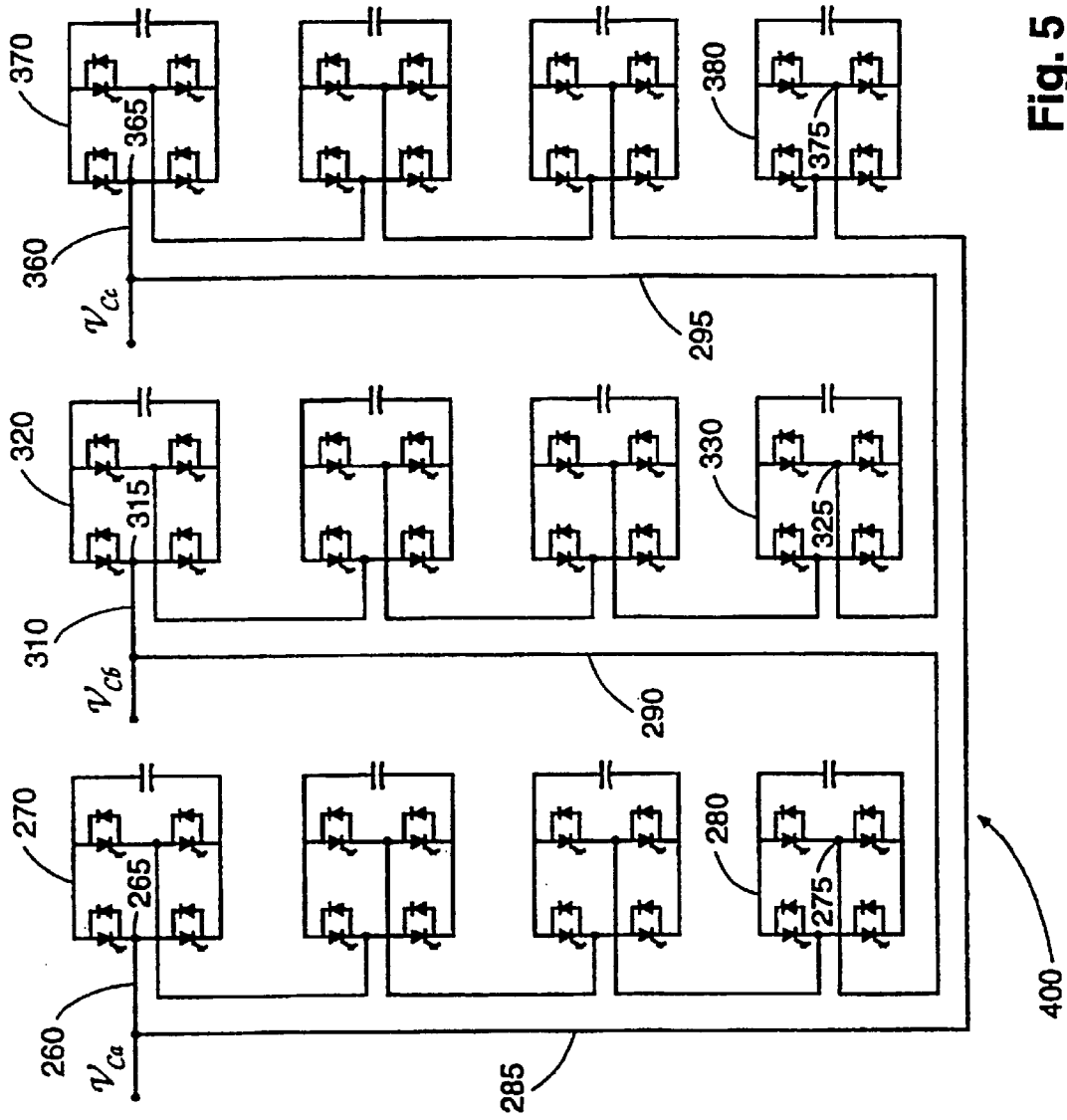

Fig. 5

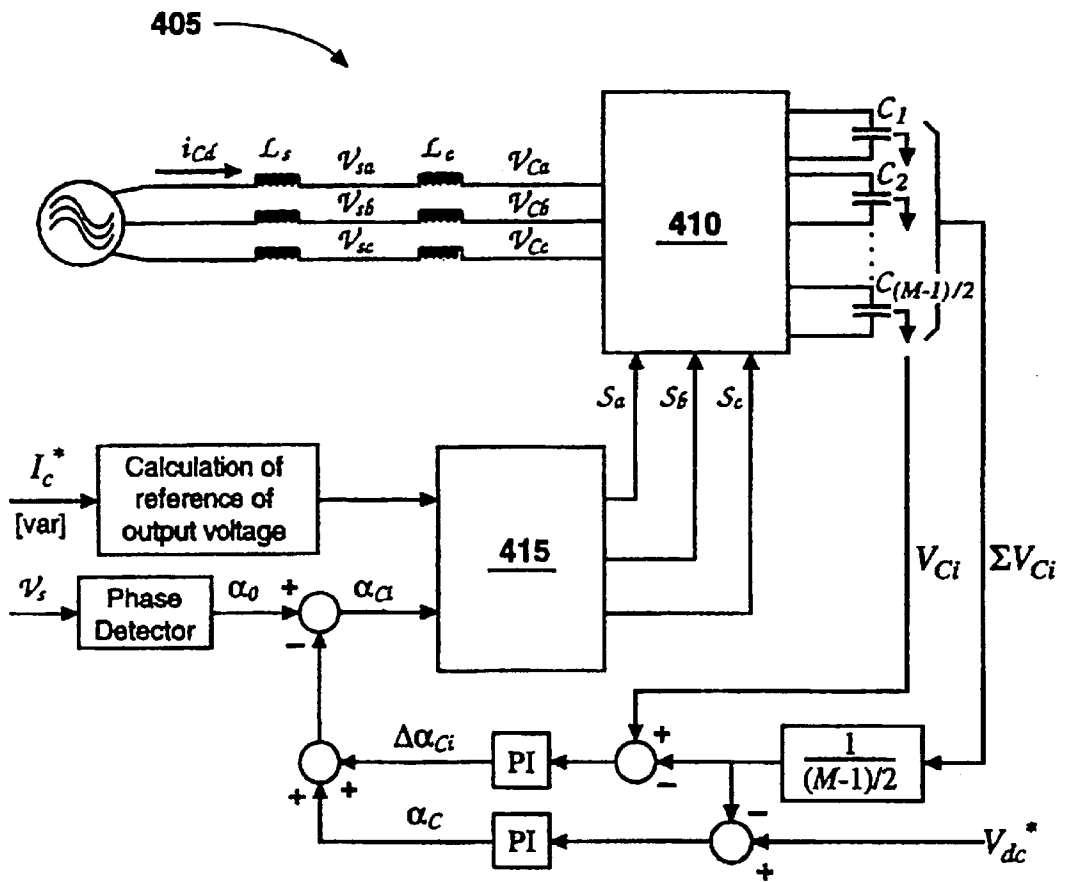
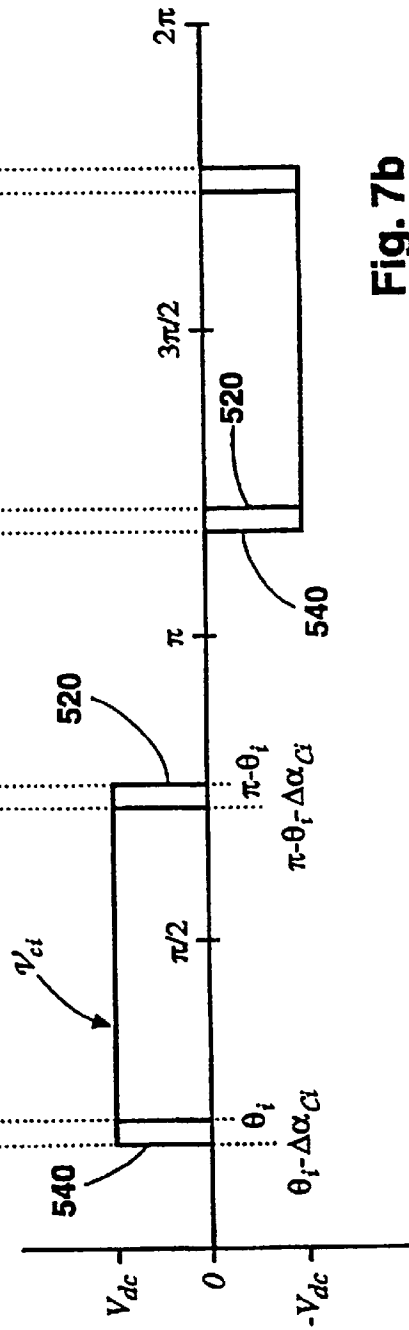
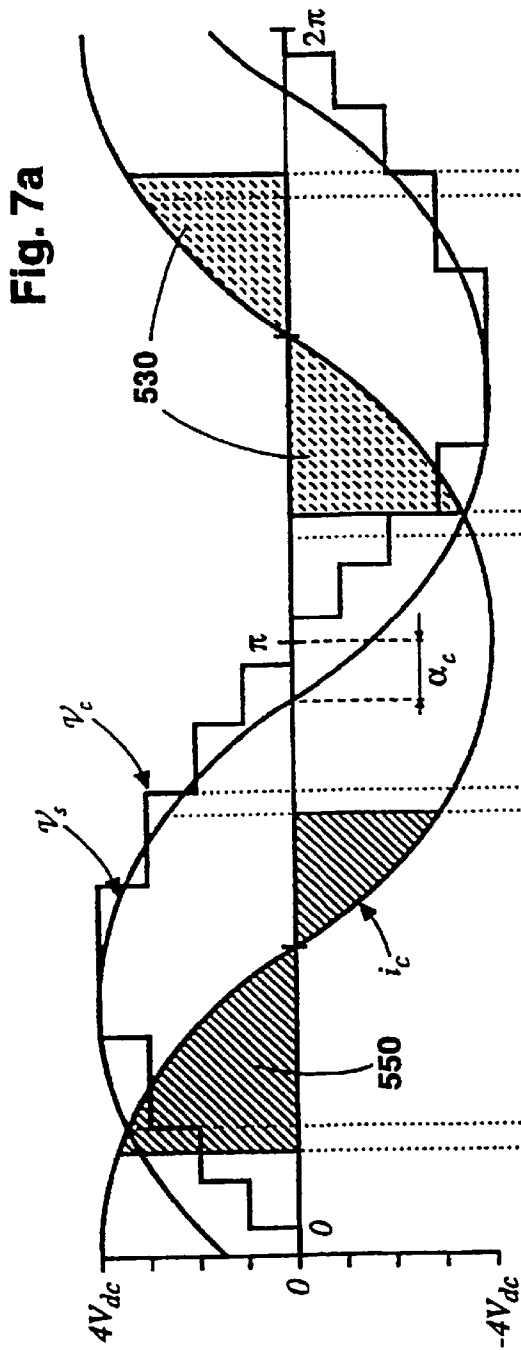
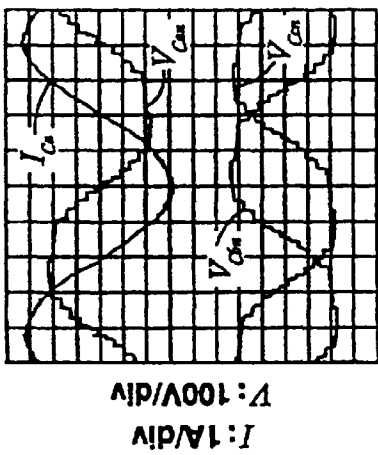

Fig. 6





$t \rightarrow 2ms/div$

Fig. 8

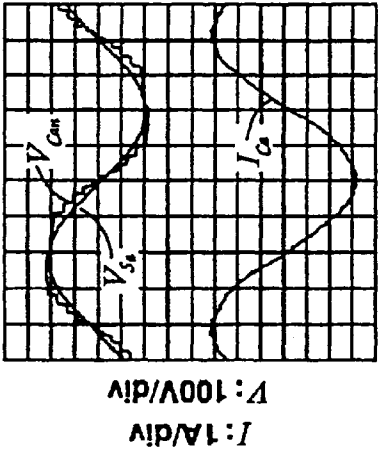

$t \rightarrow 2ms/div$

Fig. 9

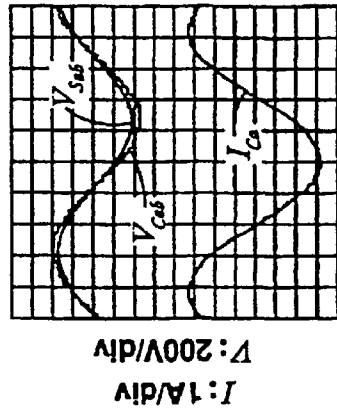

$t \rightarrow 2ms/div$

Fig. 10

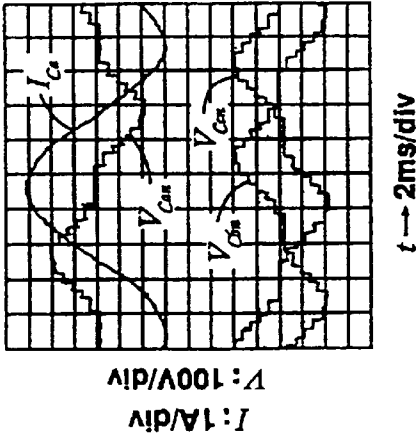

Fig. 11

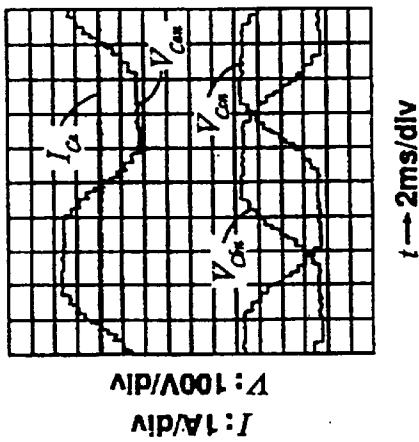

Fig. 12

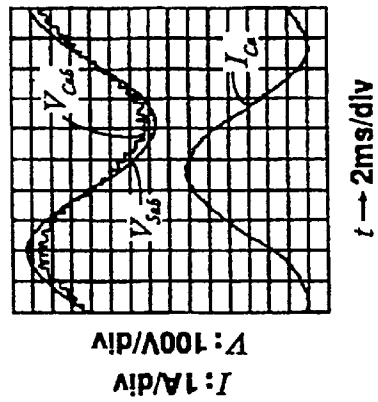

Fig. 13

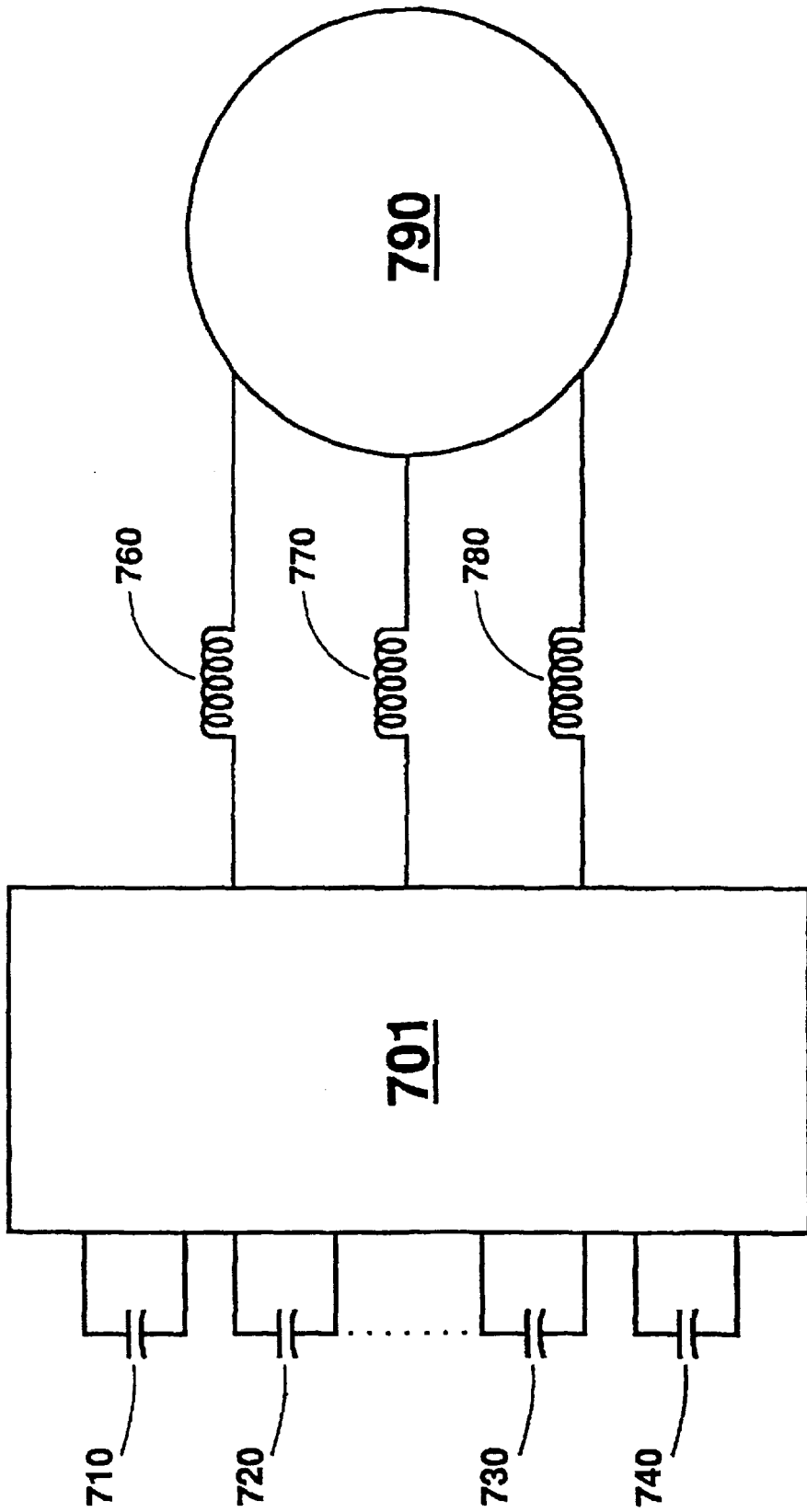

Fig. 14

MULTILEVEL CASCADE VOLTAGE SOURCE INVERTER WITH SEPERATE DC SOURCES

Matter enclosed in heavy brackets [] appears in the original patent but forms no part of this reissue specification; matter printed in italics indicates the additions made by reissue.

This application is a RE of 08/527,995, filed on Sep. 14, 1995, now U.S. Pat. No. 5,642,275.

This invention was made with Government support under contract DE-AC05-84OR21400 awarded by the U.S. Department of Energy to Lockheed Martin Energy Systems, Inc. and the Government has certain rights in this invention.

FIELD OF THE INVENTION

The present invention relates to a multilevel voltage source inverter with separate DC sources, and more particularly to a multilevel voltage source inverter with separate DC sources including an apparatus and a method for use in flexible AC transmission system (FACTS) applications such as compensating reactive power and voltage balancing.

BACKGROUND

With long distance electrical power transmission and load growth, active control of reactive power (VAR) is indispensable with regard to stabilizing power systems and maintaining supply voltages. Static VAR generators (SVGs) using voltage-source inverters have been widely accepted as the next generation of reactive power controllers for power systems replacing conventional VAR compensators such as Thyristor Switched Capacitors (TSCs) and Thyristor Controlled Reactors (TCRs).

Delivering power from a power generating station to the ultimate power consumers over long transmission lines can be very costly for an electric utility. The electric utility passes on these costs to the ultimate consumers as higher electricity bills. Inductive and capacitive losses affect a reactive component of power which is measured in volt-ampere-reactive (VAR) units. These reactive power (VAR) losses may be compensated using a static VAR compensator to more economically transmit thereby reducing overall electricity bills as well as stabilizing the supplied voltage to the end user.

The state of the art VAR compensating approach uses transformer coupling voltage source inverters. A transformer coupling voltage source inverter comprising eight six-pulse converters connected in either a zig-zag, wye or delta configuration has a 48-pulse or a 48-step staircase inverter output voltage waveform which dramatically reduces harmonics. The major problem of using this transformer coupling approach resides in the transformer as a function of harmonic neutralizing magnetics. The transformer with the inherent harmonic neutralizing magnetics deficiency:

- (a) is the most expensive equipment in the system;
- (b) produces approximately 50% of the total system losses;
- (c) occupies approximately 40% of the system layout; and
- (d) causes difficulties in system control due to DC magnetizing and surge overvoltage problems resulting from saturation of the transformers on the transient state.

In recent years, a relatively new type of inverter, a multilevel voltage source inverter, has attracted the attention of many researchers. The transformerless multilevel inverter can reach high voltage and minimize induced harmonics as a function of inverter structure.

A multilevel, referred to as M-level, diode clamped inverter can reach high performance without the benefit of transformers. This inverter does, however, require the implementation of additional clamping diodes. The number of diodes required is equal to $(M-1)*(M-2)*3$ for an M-level inverter. For example, if $M=51$, for direct connection to a 69 kV power system, then the number of required clamping diodes will be 7350. These clamping diodes not only increase the cost of the system but also cause packaging/layout problems and introduce parasitic inductances into the system. Thus, for practicality, the number of levels of a conventional multilevel diode clamped inverter is typically limited to seven or nine levels.

A relatively new inverter structure, the multilevel flying capacitor inverter has the capability to solve the voltage balance problems and aforementioned problems associated with the multilevel diode clamped inverters. The required number of flying capacitors for an M-level inverter, provided that the voltage rating of each capacitor used is the same as the main power switches is determined by the formula, $(M-1)*(M-2)*3/2+(M-1)$. Using the assumption of having capacitors with the same voltage rating, an M-level diode clamped inverter requires only $(M-1)$ capacitors. Therefore, the flying capacitor inverter requires capacitors of substantial size compared with the conventional inverter. In addition, control is very complicated and higher switching frequency is required to balance the voltages between each capacitor in the inverter.

A multilevel cascade inverter with separate DC sources for reactive power compensation in AC power systems which is directed toward overcoming and is not susceptible to the above limitations and disadvantages is described herein. The multilevel voltage source inverter having separate DC sources eliminates the excessively large number of transformers required by conventional multipulse inverters, clamping diodes required by multilevel diode-clamped inverters and flying capacitors required by multilevel flying-capacitor inverters. The multilevel voltage source inverter having separate DC sources also has the following features:

- (a) the multilevel voltage source inverter having separate DC sources is more suitable to high voltage, high power applications than conventional inverters;
- (b) the multilevel voltage source inverter having separate DC sources generates a multistep staircase voltage waveform with the switching of each device only once per line cycle, thus reaching a nearly sinusoidal output voltage approximation by increasing the number of voltage levels;
- (c) since the multilevel voltage source inverter having separate DC sources consists of cascade connections of a plurality of single-phase full bridge inverters fed with a separate DC source, neither voltage balancing nor voltage matching of switching devices is required; and
- (d) system packaging and layout is streamlined due to the simplicity and symmetry of structure as well as the minimization of component count.

Thus, a need for a multilevel cascade voltage source inverter with separate DC sources for reactive power compensation in AC power systems is clearly evident.

OBJECTS OF THE INVENTION

Accordingly, it is an object of the present invention to provide a new and improved multilevel cascade voltage source inverter and more specifically a multilevel cascade voltage source inverter for connecting to an AC high voltage, high power system.

It is another object to provide a wye configured multilevel voltage source inverter for FACTS applications such as VAR compensation and voltage balancing of AC power systems.

It is another object to provide a delta configured multilevel voltage source inverter for FACTS applications such as VAR compensation and voltage balancing of AC power systems.

It is another object to provide a multilevel voltage source inverter for connecting to an AC high voltage, high power system for a variety of applications such as fuel cells, photovoltaic utility interface systems.

It is another object to provide a method for controlling the multilevel voltage source inverter to supply a sinusoidal approximation power waveform to an AC high voltage, high power system for a variety of applications from a plurality of DC voltage sources.

Further and other objects of the present invention will become apparent from the description contained herein.

SUMMARY OF THE INVENTION

In accordance with one aspect of the present invention, a multiple voltage source inverter for connecting to an AC power system comprising a plurality of full bridge inverters having a primary node and a secondary node, each of the full bridge inverters having a positive node and a negative node, each of the full bridge inverters having a voltage supporting device electrically connected in a parallel relationship between the positive node and the negative node; at least one cascade inverter phase, each of the cascade inverter phases having a plurality of the full bridge inverters, each of the cascade inverter phases having a consistent number of the full bridge inverters with respect to each phase, each of the full bridge inverters in each cascade inverter phase interconnected in a series relationship with the secondary node of one of the full bridge inverters connected to the primary node of another full bridge inverter, the series interconnection defining a first full bridge inverter and a last full bridge inverter, each of the phases having an input node at the primary node of the first full bridge inverter and an output node at the secondary node of the last full bridge inverter; a control means connected in an operable relationship with each of the full bridge inverters to emit a square wave signal for a prescribed period therefrom; whereby, a nearly sinusoidal voltage waveform approximation is generated by the controlled, alternate activation and deactivation of the full bridge inverters by the control means.

This inverter is applicable to high voltage, high power applications such as flexible AC transmission systems (FACTS) including static VAR generation (SVG), power line conditioning, series compensation, phase shifting, voltage balancing, and fuel cell and photovoltaic utility interface systems.

In accordance with another aspect of the present invention, the multiple voltage source inverter may be configured in either a wye-connected or a delta-connected embodiment to address the requirements of multiple phase systems.

Yet another aspect of the present invention provides a method for inverting a plurality of DC voltage signals to approximate a sinusoidal voltage waveform comprising the steps of detecting the DC voltage levels of a plurality of DC voltage sources; averaging the DC voltage levels; comparing the average with a reference DC voltage; generating a first error signal from the comparison of the average with a reference DC voltage; comparing the average with the detected DC voltage levels; generating a second error signal

from the comparison of the average with the detected DC voltage levels; generating a phase shift offset signal from the second error signal; generating an average phase shift signal from the first error signal; summing the phase shift offset signal and the average phase shift signal; detecting an AC line voltage having a period; generating a phase reference signal directly related to the period of the AC line voltage; generating a plurality of firing reference signals for a plurality of full bridge inverters using the phase reference signal and the sum of the phase shift offset signal and the average phase shift signal; determining a modulation index; providing a reference table for the modulation index; generating a plurality of firing angle signals for the plurality of full bridge inverters using the firing reference signal and the reference table; whereby, the alternate activation of a plurality of gate turnoff devices in the full bridge inverters may be controlled to construct an output voltage waveform having a sinusoidal approximation for use by an AC load.

BRIEF DESCRIPTION OF THE DRAWINGS

In the drawing:

FIG. 1 is a schematic representation of a full bridge inverter.

FIG. 2 is a schematic representation of the single-phase embodiment of the multilevel DC voltage source inverter.

FIG. 3 is a graphical representation of the output voltage waveforms with respect to the input signals, v_{C1} , v_{C2} , v_{C3} and v_{C4} .

FIG. 4 is a schematic representation of the multiphase wye connected embodiment of the multilevel voltage source inverter.

FIG. 5 is a schematic representation of the multiphase delta connected embodiment of the multilevel voltage source inverter.

FIG. 6 is a control block diagram of a static VAR generator compensation system employing a three-phase multilevel cascade inverter having separate DC sources.

FIG. 7a is a waveform representation wherein v_s is the source voltage, i_c is the current flowing into the inverter and v_c is the inverter output voltage of the multilevel voltage source inverter used with the control system of FIG. 6.

FIG. 7b is a waveform representation wherein v_{ci} is the input waveform, shifted ahead by $\Delta\alpha_{ci}$, a full bridge inverter of the multilevel voltage source inverter used with the control system of FIG. 6.

FIG. 8 contains the experimental voltage waveforms showing the phase voltage results of the inverter and the line current waveform in the system of FIG. 6 at +1 kVAR output.

FIG. 9 contains the experimental voltage waveforms showing the phase voltages of the AC source and of the inverter and the line current waveform in the system of FIG. 6 at +1 kVAR output.

FIG. 10 contains the experimental voltage waveforms showing the line-to-line voltages of the AC source and of the inverter and the line current waveform of in the system of FIG. 6 at +1 kVAR output.

FIG. 11 contains the experimental voltage waveforms showing the phase voltages of the inverter and the line current in the system of FIG. 6 at 0 kVAR output.

FIG. 12 contains the experimental voltage waveforms showing the phase voltages of the inverter and the line current in the system of FIG. 6 at -1 kVAR output.

FIG. 13 contains the experimental voltage waveforms showing the line-to-line voltages of the AC source and the inverter and the line current in the system of FIG. 6 at -1 kVAR output.

FIG. 14 is a block diagram of a typical application of a multiphase, multilevel cascade inverter with separate DC sources connected to an AC load.

For a better understanding of the present invention, together with other and further objects, advantages and capabilities thereof, reference is made to the following disclosure and appended claims in connection with the above-described drawings.

DETAILED DESCRIPTION OF THE INVENTION

Referring now in detail to the drawings wherein like parts are designated by like reference numerals throughout, there is illustrated in FIG. 1 a schematic representation showing the primary building block of the preferred embodiment of the apparatus of the present invention, a single-phase, full-bridge inverter (FBI) unit 50. A FBI unit comprises a primary node 1 and a secondary node 2 and an inverting means therebetween. The inverting means comprises four switching means further comprising gate turn-off devices 10, 20, 30 and 40 and anti-parallel diodes 15, 25, 35 and 45 connected in an operable, oppositely biased, parallel relationship by conductors 17, 18, 27, 28, 37, 38, 47 and 48, respectively. The gate turn-off devices may be any of the components capable of switching such as gate turn-off thyristors, insulated gate bipolar transistors, power MOSFETs, MOSFET controlled thyristors, bipolar junction transistors, static induction transistors, static induction thyristors or MOSFET turn-off thyristors. The first switching means is connected to the second switching means by conductors 22 and 24 through positive node 26. The second and third switching means are connected by conductors 23 and 33 through secondary node 2. The third and fourth switching means are connected by conductors 32 and 34 through negative node 36. The first and fourth switching means are connected by conductors 11 and 12 through primary node 1. A voltage supporting device 5, most commonly a capacitor, is connected between positive node 26 and negative node 36 by conductors 6 and 7, respectively. The voltage supporting device 5 may be any device, such as a DC voltage source or a capacitor, capable of maintaining a DC voltage for a sufficient period of time.

The FBI unit 50 can generate three level outputs; $+V_{DC}$, 0 and $-V_{DC}$ at the respective primary node 1. This is permitted by connecting the DC source 5 to the AC side of the FBI unit 50 via the four switching devices 10, 20, 30 and 40. Each switching device 10, 20, 30 and 40 is switched, wherein switching is defined by the activation and deactivation of the respective switching device, only once per power line cycle in an alternating fashion commonly known to one of ordinary skill in the art to produce the $+V_{DC}$, 0 and $-V_{DC}$ output voltages across the primary node 1 and the secondary node 2. The switching action is generally controlled by an external control means using either analog or digital control signals in a manner commonly known to one of ordinary skill in the art.

SINGLE-PHASE EMBODIMENT

FIG. 2 shows the single-phase embodiment 100 of the multilevel cascade inverter having separate DC voltage sources. The single-phase embodiment 100 comprises n FBI units 60, 70, 80 and 90 wherein n is determined by:

$$n = \frac{(M-1)}{2} \quad (\text{Eq. 1})$$

wherein M is the number of output voltage levels generated by the multilevel cascade inverter during a half fundamental cycle.

FBI units 60 and 70 are interconnected between primary node 75 and secondary node 66 by conductor 51. FBI units 70 and 80 are interconnected between primary node 85 and secondary node 76 by conductor 52. FBI units 80 and 90 are interconnected between primary node 95 and secondary node 86 by conductor 53. The primary node 65 of the first FBI unit 60 in the multilevel cascade inverter functions as the output of the cascade inverter single-phase embodiment 100. The secondary node 96 of the last FBI unit 90 in the multilevel cascade inverter functions as the reference of the cascade inverter single-phase embodiment 100. The FBI units are provided with separate DC voltage sources 63, 73, 83 and 93.

The schematic represented in FIG. 2 shows the M level, single phase cascade inverter 100 wherein $M=9$. FIG. 3 shows the waveform response of the circuit shown in FIG. 2 wherein a DC voltage input was injected by independent voltage sources 63, 73, 83 and 93. The waveform v_{Cp} is measured between node 65 and node 96 using the output waveforms shown as v_{C1} , v_{C2} , v_{C3} and v_{C4} , injected by 60, 70, 80 and 90, respectively. It is obvious to one of ordinary skill in the relevant art that v_{Cp} as shown in FIG. 3 with reference to v_{Cn} may be accurately described by:

$$v_{Cp} = v_{C1} + v_{C2} + v_{C3} + v_{C4} \quad (\text{Eq. 2})$$

wherein v_{C1} , v_{C2} , v_{C3} and v_{C4} are the respective voltage output levels of the each FBI unit in the single phase cascade inverter 100 as shown in FIG. 2.

THREE-PHASE, WYE CONNECTED EMBODIMENT

FIG. 4 shows the three-phase, wye connected embodiment 250 of the multilevel cascade inverter having separate DC voltage sources. The wye connected embodiment 250 comprises three distinct phases 110, 160 and 210, each phase having a multilevel cascade inverter comprising a plurality of FBI units. Each multilevel cascade is constructed as previously described in the single-phase embodiment discussion. The primary nodes 115, 165 and 215 of the first FBI units 120, 170 and 220 in each phase of the multilevel cascade is the phase output for each of the respective phases 110, 160 and 210. The secondary nodes 125, 175 and 225 of the last FBI units 130, 180 and 230 in each phase of the multilevel cascade are electrically connected to create a common node 200 therebetween.

The operative aspects of the three-phase, wye connected embodiment of the multilevel cascade inverter having separate DC sources are identical to the single-phase embodiment as previously discussed.

THREE-PHASE, DELTA CONNECTED EMBODIMENT

FIG. 5 shows the three-phase, delta connected embodiment 400 of the multilevel cascade inverter having separate DC voltage sources. The delta connected embodiment 400 comprises three distinct phases 260, 310 and 360, each phase having a multilevel cascade inverter comprising a

plurality of FBI units. Each multilevel cascade is constructed as previously described in the single-phase embodiment. The primary nodes **265**, **315** and **365** of the first FBI units **270**, **320** and **370** in each phase of the multilevel cascade is the phase output for the respective phases **260**, **310** and **360**. The primary node **265** of FBI unit **270** is electrically connected to the secondary node **375** of the FBI unit **380** by conductor **285**. The primary node **315** of FBI unit **320** is electrically connected to the secondary node **275** of the FBI unit **280** by conductor **290**. The primary node **365** of FBI unit **370** is electrically connected to the secondary node **325** of the FBI unit **330** by conductor **295**.

The operative aspects of the three-phase, delta connected embodiment of the multilevel cascade inverter having separate DC sources are identical to the single-phase embodiment as previously discussed.

SYSTEM CONFIGURATION AND CONTROL SCHEME FOR SVGs

FIG. 6 shows a control block diagram of a SVG **405** employing a three-phase multilevel cascade inverter **410** having separate DC sources as described herein. In FIG. 6, v_s represents the source voltage, L_s the source impedance and L_c the inverter interface impedance, respectively. The multilevel cascade inverter discussed in this example will be the inverter previously discussed for the multilevel, wye connected embodiment **250**. Variations therefrom utilizing other embodiments previously discussed will be obvious to one of ordinary skill in the relevant art. The switching pattern table **415** contains switching timing data for the multilevel cascade inverter **410** to generate the desired phase output voltage as shown in FIG. 3. The switching angles, θ_i , where $i=1, 2, (M-1)/2$, are calculated off-line by conventional methods to minimize harmonics for each modulation index, MI, described by:

$$MI = \frac{V_c^*}{V_{Cmax}} \quad (\text{Eq. 3})$$

wherein V_c^* is the amplitude command of the inverter output phase voltage and V_{Cmax} is the maximum obtainable amplitude, i.e., the amplitude of the phase voltage when all switching angles, θ_i , are equal to zero.

Since the phase current, i_{Ci} , graphically displayed in FIG. 3 is either leading or lagging the phase voltage v_{Cin} by 90 degrees, the average charge to each DC voltage supporting device is equal to zero over every half line cycle. From FIG. 3, the average charge to each DC voltage supporting device, Q_i , over half cycle 0 to π can be expressed as:

$$Q_i = \int_{\theta_i}^{\pi-\theta_i} I_c \cos \theta d\theta = 0 \quad (\text{Eq. 4})$$

where, $i=1, 2, 3$ and 4 with respect to FIB. 4 and θ_i to $\pi-\theta_i$ represents the interval of connecting the DC voltage supporting device to the AC side of the FBI unit and I is the magnitude of the line current i_c . This configuration allows balanced DC voltages on each DC voltage supporting device in each FBI unit of each phase of the multilevel, wye connected cascade inverter due to equal charge and discharge of the voltage supporting devices.

As previously discussed, the average charge to each DC voltage supporting device will be zero if each FBI unit output voltage, v_{Ci} , is exactly 90 degrees out-of-phase with the line current, i_c , as shown in FIG. 3. Therefore the DC

voltage supporting device, in this case a capacitor, sees no real power. Even without real power imparted on the respective capacitors, the capacitor voltage can not be maintained due to switching device losses and capacitor losses. Therefore to maintain each DC capacitor voltage, the inverter must be controlled to allow some real power to influence the DC capacitors to maintain the DC command voltage V_{DC}^* .

The control block diagram shown in FIG. 6 includes two distinct control loops. The outer loop, defined by the influence of the DC command voltage V_{DC}^* , is to control total power flow to the FBI units, whereas the inner loop, defined by the feed back from the individual FBI units, is to offset power flow to the individual FBI units.

[The control principle can be explained with the assistance of FIGS. 7a and 7b. In FIG. 7a, v_s is the source voltage, i_c is the current flowing into the inverter and v_c is the inverter output voltage. If v_c is controlled so that v_c lags v_s by α_c , then the total real power flowing into the inverter, P_i , is:

$$P_i = \frac{V_s V_c \sin \alpha_c}{X_{Lc}} \quad (\text{Eq. 5})$$

where X_{Lc} is the inductance of the interface inductor L_c . Since the devices, e.g. capacitors, diodes, etc., used in the construction of the multilevel cascade inverter **410** are not ideal and therefore have varying tolerances, each DC capacitor voltage can not be exactly balanced using the outer loop only. Referring to FIGS. 7a and 7b, if FBI unit I output voltage, v_{Ci} , is as shown by trace **520**, then the average charge into the DC capacitor over each half cycle, the second shaded area **530**, will nearly equal zero. However, if v_{Ci} is shifted ahead by $\Delta\alpha_{Ci}$ as shown by trace **540**, the charge shown in area **550** can be expressed as:

$$Q_i = \int_{\theta_i - \Delta\alpha_{Ci}}^{\pi - \theta_i - \Delta\alpha_{Ci}} I_c \cos \theta d\theta = 2I_c \cos \theta_i \sin \Delta\alpha_{Ci} \quad (\text{Eq. 6})$$

which is proportional to $\Delta\alpha_{Ci}$ when $\Delta\alpha_{Ci}$ is small. Therefore, each FBI unit DC capacitor voltage can be actively controlled by slightly shifting the switching pattern. In the case for high voltage, high power applications, total power loss for the multilevel cascade inverter **410** is typically less than one percent.]

The control principle can be explained with the assistance of FIGS. 7a and 7b. In FIG. 7a, V_2 is the source voltage, i_c is the current flowing into the inverter, and V_c is the inverter output voltage. If V_c is controlled so that V_c lags V_2 by α_c , then the total real power flowing into the inverter, P_i is:

$$P_i = \frac{V_s V_c \sin \alpha_c}{X_{Lc}} \quad (\text{Eq. 5})$$

where X_{Lc} is the inductance of the interface inductor L_c . Since the devices, e.g., capacitors, diodes, etc., used in the construction of the multilevel cascade inverter **410** are not ideal and therefore have varying tolerances, each DC capacitor voltage can not be exactly balanced using the outer loop only. Referring to FIGS. 7a and 7b, if FBI unit I output voltage, v_{C1} is as shown by trace **520**, then the average charge into the DC capacitor over each half cycle, the second shaded area **530**, will nearly equal zero. However, if v_{C1} is shifted ahead by $\Delta\alpha_{C1}$ as shown by trace **540**, the charge shown in area **550** can be expressed as:

$$Q_i = \int_{\theta_i - \Delta\alpha_{Ci}}^{\pi - \theta_i - \Delta\alpha_{Ci}} I \cos \theta d\theta = 2I \cos \theta_i \sin \Delta\alpha_{Ci} \quad (\text{Eq. 6})$$

which is proportional to $\Delta\alpha_{Ci}$ when $\Delta\alpha_{Ci}$ is small. Therefore, each FBI unit DC capacitor voltage can be actively controlled by slightly shifting the switching pattern. In the case for high voltage, high power applications, total power loss for the multilevel cascade inverter 410 is typically less than one percent.

The method used to control the automatic switching of the FBIs may be best described with reference to FIG. 6. First, the voltage supporting device DC voltage levels, V_{Ci} , are detected, summed and then averaged. The average DC voltage level is then compared with a system reference DC voltage, V_{dc}^* . Using a proportional integrator, an average phase shift signal, α_C , is generated from a first error signal describing the comparison between the average DC voltage level and the system reference DC voltage, V_{dc}^* . The average DC voltage level is also compared with the respective detected DC voltage levels, V_{Ci} . Using a proportional integrator, a phase shift offset signal, $\Delta\alpha_{Ci}$, is generated from a second error signal describing the comparison between the average DC voltage level and the respective detected DC voltage levels, V_{Ci} . The phase shift offset signal, $\Delta\alpha_{Ci}$, and said average phase shift signal, α_C , are then summed. An AC line voltage, V_s , having a period is detected from which a phase reference signal, α_0 , directly related to the period of the AC line voltage, V_s , is developed by comparison with the sum of the phase shift offset signal $\Delta\alpha_{Ci}$, and said average phase shift signal, α_C . Multiple firing reference signals, α_{Ci} , for the FBIs are generated by comparing the phase reference signal, α_0 , and the sum of phase shift offset signal, $\Delta\alpha_{Ci}$, and the average phase shift signal, α_C . A modulation index, MI, may be selected by the user for which a corresponding reference table is provided. Firing angle signals are generated for the FBIs using the firing reference signal in view of the reference table for the given modulation index, MI, whereby, the alternate activation of a plurality of gate turn-off devices in the FBIs may be controlled to construct an output voltage waveform having a sinusoidal approximation for use by an AC load.

REQUIRED CAPACITANCE OF DC CAPACITANCE

Since each phase of the multilevel cascade inverter described herein has independent DC capacitors, the required capacitance calculation of each FBI unit DC capacitor is straightforward. With reference to FIG. 3, the required capacitance, C_i , can be expressed as:

$$C_i = \frac{\Delta Q_i}{\Delta V_{dc}} = \frac{\int_{\theta_i(t)}^{\pi/4} \sqrt{2} I \cos \theta dt}{2\epsilon V_{dc}} = \frac{\sqrt{2} I (1 - \sin \theta_i)}{2\cos \epsilon V_{dc}} \quad (\text{Eq. 7})$$

where I is the current rating of the inverter, ϵ is the given regulation factor of the DC voltage and θ_i is the switching timing angle of FBI unit I as shown in FIG. 3. Note that:

$$I = I_{SVG} \quad (\text{Eq. 8})$$

for the wye connected embodiment and:

$$I = \frac{I_{SVC}}{\sqrt{3}} \quad (\text{Eq. 9})$$

for the delta connected embodiment. The total required capacitance for a three-phase M-level converter, C, may be expressed as

$$C = 3 \sum_{i=1}^{(M-1)/2} C_i \quad (\text{Eq. 10})$$

As previously discussed, θ_i is calculated for each MI value. To generate $\pm Q_{VAR}$ reactive power, MI would change between MI_{min} and MI_{max} , wherein the SVG produces $+Q_{VAR}$ when $MI=MI_{max}$ and produces $-Q_{VAR}$ for $MI=MI_{min}$. For $MI=MI_{max}$, θ_i becomes minimum and for $MI=MI_{min}$, θ_i becomes maximum. Therefore, $\theta_{i \text{ at } MI=MI_{max}}$ may be used in equation 6 to calculate the required capacitance to maintain the DC voltage ripple below the given regulation, ϵ , for all loads.

EXAMPLE

A SVG system as shown in FIG. 6 having an 11-level wye-connected cascade inverter with 5 FBI units per phase was constructed having the system parameters shown in Table 1. The switching timing angles, θ_i , wherein $i=1, 2, 3, 4, 5$, shown in Table 2, were specifically calculated for minimizing voltage harmonics, below the 25th order, and stored in the switching pattern table 415 shown in FIG. 6.

TABLE 1

System Parameters of Experimental Prototype	
System Parameter	Value
Source Voltage Rating, V_s	240 V
VAR Rating, Q_{VAR}	± 1 kVAR
Current Rating, I	2.4 A
DC Voltage, V_{dc}	40 V
DC Voltage Regulation, ϵ	$\pm 5\%$
Interface Inductance, L_C	20% (32 mH)
Source Impedance, L_S	3%
Modulation Index, MI_{min}, MI_{max}	0.615, 0.915

TABLE 2

Switching Pattern Table of 11-Level Cascade Inverter					
Modulation Index	Switching Timing Angles (rad.)				
	θ_1	θ_2	θ_3	θ_4	θ_5
0.615	0.4353	0.7274	0.8795	1.0665	1.2655
...
0.915	0.0687	0.1595	0.3124	0.4978	0.7077

Using the parameters of Tables 1 and 2 and Equations 7 and 10, the following values may be calculated:

- $C_1=2.1$ mF;
- $C_2=1.89$ mF;
- $C_3=1.56$ mF;
- $C_4=1.18$ mF; and
- $C_5=0.79$ mF.

The total capacitance is calculated:

$$C=22.56 \text{ mF.}$$

As the number of inverter cascade levels is increased for high voltage applications, the required capacitance of the cascade inverter, C , will approach that of a conventional multipulse inverter, C_{dc} , wherein the ratio C/C_{dc} will approach one as a limit.

EXAMPLE

An SVG system using the delta connected embodiment of a 21-level cascade inverter having 10 FBI units per phase is connected directly to a 13 kV distribution system. The SVG capacity is ± 50 MVAR. $I_{SVG}=2.22$ kA, $I=1.282$ kA, $L_c=3\%$, $MI_{min}=0.6385$, $MI_{max}=0.8054$, $V_{dc}=2$ kV and $\epsilon=\pm 5\%$. At the rated load of +50 MVAR, $[\theta_1, \theta_2, \dots, \theta_i]=[0.0334, 0.1840, 0.2491, 0.3469, 0.4275, 0.5381, 0.6692, 0.8539, 0.9840, 1.1613]$ rad. For this SVG system, the total required capacitance of DC capacitors can be calculated as $C=370$ mF. The required capacitance for a comparable conventional multipulse inverter will be $C_{dc}=332$ mF. Therefore, the ratio C/C_{dc} approached unity at 1.11.

SIMULATION AND EXPERIMENTAL RESULTS

To demonstrate the validity of the multilevel cascade inverter described herein, an SVG prototype using an 11-level wye-connected cascade inverter was built. FIG. 6 and Tables 1 and 2 show the experimental configuration and the corresponding parameters. For the DC voltage control loops, only the voltages of C_1 and C_5 of phase "a" are detected and controlled directly. The control voltages for C_2 , C_3 and C_4 uses interpolating values of $\Delta\alpha_{C1}$ and $\Delta\alpha_{C5}$.

FIGS. 8, 9 and 10 show the experimental results when the SVG generates +1 kVAR reactive power. FIG. 11 shows experimental results at zero VAR output. FIGS. 12 and 13 show the case of generating -1 kVAR reactive power.

From FIGS. 8, 9 and 10 it is demonstrated that the inverter output phase voltage is an 11-level steplike waveform and the line-to-line voltage is a 21-level steplike waveform over a half cycle. Each step has the same span, which means the voltage of each DC capacitor is well controlled and balanced. The DC voltage command, V_{dc}^* , was 40 V, and the modulation index was the maximum, $MI=0.915$, in this case.

It is well known to those of ordinary skill in the art that either the modulation index or the DC voltage or both may be controlled to regulate the output voltage. FIG. 12 shows the experimental waveforms to generate zero reactive power or zero current with a different DC voltage and the same modulation index as that of FIGS. 8, 9 and 10. In this case, the DC voltage of each DC capacitor was controlled to be 34 V, $V_{dc}^*=34$ V.

In FIGS. 12 and 13, $MI=0.615$ and $V_{dc}^*=40$ V. The inverter generates -1 kVAR of reactive power, that is, the current, I_{Ca} , is lagging the voltage, V_{sa} , by 90 degrees.

These experimental results show that the voltages of the DC capacitors are well balanced. The results also show that pure sinusoidal current has been obtained with only 20% impedance on the AC side of the inverter. Using the delta-connected embodiment of the cascade inverter can compensate for a balanced or unbalanced three-phase load reactive power.

APPLICATIONS FOR CASCADE INVERTERS WITH SEPARATE DC SOURCES

Applications for the multilevel cascade voltage source inverters with separate DC sources are not limited to static

VAR compensation or power system applications. These multilevel cascade inverters may also be used for providing clean AC power to AC loads with separate DC sources. FIG. 14 shows a circuit diagram having a multiphase, multilevel cascade inverter with separate DC sources 701 connected to an AC load 790 through smoothing inductors 760, 770 and 780. Typically, this circuit contains a set of separate DC voltage sources 710, 720, 730 and 740 which feed through a multilevel cascade inverter 701 to produce a step-like AC output voltage waveform. The voltage is then filtered by small smoothing inductors 760, 770 and 780 to produce a pure sinusoidal wave for an AC load 790. If the specific application is for AC motors, then the smoothing inductors 760, 770 and 780 may be removed from the circuit because the load motor has sufficient inductance to filter the input current. Examples of typical loads comprise motor drives, actuators and appliances. The DC voltage sources 710, 720, 730 and 740 may be obtained from any type conventional voltage source such as batteries, capacitors, photocells, fuel cells and biomass.

While there has been shown and described what is at present considered the preferred embodiments of the invention, it will be obvious to those skilled in the art that various changes and modifications can be made therein without departing from the scope of the invention deformed by the appended claims.

What is claimed is:

1. A multiple DC voltage source inverter for connecting to an AC power system, comprising:

a. a plurality of full bridge inverters having a primary node and a secondary node, each of said full bridge inverters having a positive node and a negative node, each of said full bridge inverters having a voltage supporting device electrically connected in a parallel relationship between said positive node and said negative node;

b. at least one cascade inverter phase, each cascade inverter phase having a plurality of said full bridge inverters, each cascade inverter phase having a consistent number of said full bridge inverters with respect to each phase, each of said full bridge inverters in each cascade inverter phase interconnected in a series relationship with said secondary node of one of said full bridge inverters connected to said primary node of another full bridge inverter, said series interconnection defining a first full bridge inverter and a last full bridge inverter, each phase having an input node at said primary node of said first full bridge inverter and an output node at said secondary node of said last full bridge inverter;

c. a control means connected in an operable relationship with each of said full bridge inverters to [emit a square wave signal for a prescribed period therefrom; whereby,] detect a period and a reference signal associated with the AC power system and to alternate activation and deactivation of each of said full bridge inverters in response to the reference signal to create a nearly sinusoidal voltage waveform approximation [is generated by the controlled, alternate activation and deactivation of said full bridge inverters by said control means] having substantially the same period as the AC power system and having a desired phase shift defined with respect to the reference signal.

2. A multiple DC voltage source inverter for connecting to an AC power system as described in claim 1 having three cascade inverter phases.

3. A multiple DC voltage source inverter for connecting to an AC power system as described in claim 2 having a

13

plurality of phase connectors, one of said phase connectors electrically connected between said input node of the first of said cascade inverter phases and said output node of the third of said cascade inverter phases, another of said phase connectors electrically connected between said input node of the third of said cascade inverter phases and said output node of the second of said cascade inverter phases, another of said phase connectors electrically connected between said input node of the second of said cascade inverter phases and said output node of the first of said cascade inverter phases.

4. A multiple DC voltage source inverter for connecting to an AC power system as described in claim 3 further comprising each of said full bridge inverters having a first switching pair and a second switching pair, each of said switching pairs having a plurality of switching means for controllably regulating electrical current flow, each of said switching means having a first end and a second end, said first switching pair having a plurality of switching means electrically connected at said first end at said positive node of said full bridge inverter, said second end of one of said switching means of said first switching pair electrically connected to said primary node, said second end of another of said switching means of said first switching pair electrically connected to said secondary node, said second switching pair having a plurality of switching means electrically connected at said second ends at said negative node of said full bridge inverter, said first end of one of said switching means of said second switching pair electrically connected to said primary node, said first end of another of said switching means of said second switching pair electrically connected to said secondary node.

5. A multiple DC voltage source inverter for connecting to an AC power system as described in claim 4 wherein said switching means comprises a gate turn-off device and an anti-parallel device connected in parallel and oppositely biased with respect to one another.

6. A multiple DC voltage source inverter for connecting to an AC power system as described in claim 5 wherein said gate turn-off device is a component selected from the group consisting of a gate turn-off thyristor, an insulated gate bipolar transistor, a power MOSFET, a MOSFET controlled thyristor, a bipolar junction transistor, a static induction transistor, a static induction thyristor and a MOSFET turn-off thyristor.

7. A multiple DC voltage source inverter for connecting to an AC power system as described in claim 5 wherein said anti-parallel device is a diode.

8. A multiple DC voltage source inverter for connecting to an AC power system as described in claim 1 wherein each of said voltage supporting devices is a component selected from the group consisting of capacitors, fuel cells, photovoltaic cells and biomass [cells] cells.

9. A multiple DC voltage source inverter for connecting to an AC power system having a plurality of phases, comprising:

- a. a plurality of full bridge inverters having a primary node and a secondary node, each of said full bridge inverters having a positive node and a negative node, each of said full bridge inverters having a voltage supporting device electrically connected in a parallel relationship between said positive node and said negative node;
- b. a plurality of cascade inverter phases, each of said cascade inverter phases corresponding to one of the phases of the AC power system and having a plurality of said full bridge inverters, each of said cascade inverter phases having a consistent number of said full

14

bridge inverters with respect to each phase, each of said full bridge inverters in each cascade inverter phase interconnected in a series relationship with said secondary node of one of said full bridge inverters connected to said primary node of another full bridge inverter, said series interconnection defining a first full bridge inverter and a last full bridge inverter, each of said phases having an input node at said primary node of said first full bridge inverter and an output node at said secondary node of said last full bridge inverter;

c. a common node defined by the electrical interconnection of said output nodes of each of said cascade inverter phases; and

d. a control means connected in an operable relationship with each [of said full bridge inverters to emit a square wave signal for a prescribed period therefrom;

whereby,] *cascade inverter phase to detect a period and a phase reference signal associated with a corresponding phase of the AC power system and to alternate activation and deactivation of each of the full bridge inverters of the cascade inverter phase in response to the phase reference signal to create a nearly sinusoidal voltage waveform approximation [is generated by the controlled, alternate activation and deactivation of said full bridge inverters by said control means] having substantially the same period as the corresponding phase of the AC power system and having a desired phase shift defined with respect to the phase reference signal.*

10. A multiple DC voltage source inverter for connecting to an AC power system as described in claim 9 further comprising each of said full bridge inverters having a first switching pair and a second switching pair, each of said switching pairs having a plurality of switching means for controllably regulating electrical current flow, each of said switching means having a first end and a second end, said first switching pair having a plurality of switching means electrically connected at said first end at said positive node of said full bridge inverter, said second end of one of said switching means of said first switching pair electrically connected to said primary node, said second end of another of said switching means of said first switching pair electrically connected to said secondary node, said second switching pair having a plurality of switching means electrically connected at said second ends at said negative node of said full bridge inverter, said first end of one of said switching means of said second switching pair electrically connected to said primary node, said first end of another of said switching means of said second switching pair electrically connected to said secondary node.

11. A multiple DC voltage source inverter for connecting to an AC power system as described in claim 10 wherein said switching means comprises a gate turn-off device and an anti-parallel device connected in parallel and oppositely biased with respect to one another.

12. A multiple DC voltage source inverter for connecting to an AC power system as described in claim 11 wherein said gate turn-off device is a component selected from the group consisting of a gate turn-off thyristor, an insulated gate bipolar transistor, a power MOSFET, a MOSFET controlled thyristor, a bipolar junction transistor, a static induction transistor, a static induction thyristor and a MOSFET turn-off thyristor.

13. A multiple DC voltage source inverter for connecting to an AC power system as described in claim 11 wherein said anti-parallel device is a diode.

14. A multiple DC voltage source inverter for connecting to an AC power system as described in claim 9 wherein each

15

of said voltage supporting devices is a component selected from the group consisting of capacitors, fuel cells, photovoltaic cells and biomass cells.

15 15. A multiple DC voltage source inverter for connecting to a AC power system as described in claim 9 having three cascade inverter phases.

16. A method for inverting a plurality of DC voltage signals to approximate a [sinusoidal] sinusoidal voltage waveform comprising the following steps:

- a. detecting the DC voltage levels of a plurality of DC voltage sources;
- b. averaging said DC voltage levels;
- c. comparing said average with a reference DC voltage;
- d. generating a first error signal from said comparison of said average with a reference DC voltage;
- e. comparing said average with said detected DC voltage levels;
- f. generating a second error signal from said comparison of said average with said detected DC voltage levels;
- g. generating a phase shift offset signal from said second error signal;
- h. generating an average phase shift signal from said first error signal;
- i. summing said phase shift offset signal and said average phase shift signal;
- j. detecting an AC line voltage having a period;
- k. generating a phase reference signal directly related to said period of said AC line voltage;
- l. generating a plurality of firing reference signals for a plurality of full bridge inverters using said phase reference signal and said sum of said phase shift offset signal and said average phase shift signal;
- m. determining a modulation index;
- n. providing a reference table for said modulation index;
- o. generating a plurality of firing angle signals for said plurality of full bridge inverters using said firing reference signal and said reference table;

whereby, the alternate activation of a plurality of gate turn-off devices in said full bridge inverters may be controlled to construct an output voltage waveform having a sinusoidal approximation for use by an AC load.

17. The multiple DC voltage source inverter of claim 1, wherein:

the phase shift is selected to generate a desired level of positive or negative reactive power delivered to the AC power system while generating sufficient real power to offset losses incurred within the full bridge inverters.

18. The multiple DC voltage source inverter of claim 1, further comprising a smoothing inductor connected in series between the cascade inverter phase and the AC power system.

19. The multiple DC voltage source inverter of claim 1, wherein:

the phase shift is selected to perform a flexible AC transmission operation selected from the group including static VAR generation, power line conditioning, series compensation, phase shifting, voltage balancing, and generator interfacing.

20. The multiple DC voltage source inverter of claim 2, wherein the AC power system includes three phases corresponding to the three cascade inverter phases, further comprising three smoothing inductors, one of the smoothing inductors connected in series between each cascade inverter phase and a corresponding phase of the AC power system.

16

21. The multiple DC voltage source inverter of claim 10, wherein:

the phase shift for each cascade inverter phase is selected to generate a desired level of positive or negative reactive power delivered to the corresponding phase of the AC power system while generating sufficient real power to offset losses incurred within the cascade inverter phase.

22. The multiple DC voltage source inverter of claim 10, further comprising a smoothing inductor connected in series between each of the cascade inverter phases and a corresponding phase of the AC power system.

23. The multiple DC voltage source inverter of claim 10, wherein:

the phase shift for each cascade inverter phase is selected to perform a flexible AC transmission operation selected from the group including static VAR generation, power line conditioning, series compensation, phase shifting, voltage balancing, and generator interfacing.

24. A multiple DC voltage source inverter for connecting to an AC power system, comprising:

at least one cascade inverter phase including a plurality of full bridge inverters connected in a series relationship;

a control means connected in an operable relationship with each of said full bridge inverters to detect a period and a reference signal associated with the AC power system and to alternate activation and deactivation of each of said full bridge inverters in response to the reference signal to create a nearly sinusoidal voltage waveform approximation having substantially the same period as the AC power system and having a desired phase shift defined with respect to the phase reference signal; and

a smoothing inductor connected in series between the cascade inverter phase and the AC power system.

25. The multiple DC voltage source inverter of claim 24, wherein the control means further comprises:

a first control loop for controlling the power flow to the cascade inverter phase; and

a second feed-back control loop for offsetting the power flow to each of the full bridge inverters of the cascade inverter phase.

26. The multiple DC voltage source inverter of claim 24, wherein the control means further comprises:

a switching pattern table containing switching timing data for generating the nearly sinusoidal voltage waveform approximation in response to a reference output voltage signal and a desired phase angle;

means for calculating the reference output voltage signal;

a phase detector for determining the reference signal; and means for determining the desired phase angle in response to the reference signal and a feedback signal produced by the first and second control loops.

27. The multiple DC voltage source inverter of claim 26, wherein:

the AC power system includes three phases;

the cascade inverter includes three phases, one cascade inverter phase corresponding to each phase of the AC power system;

the cascade inverter includes three smoothing inductors, one smoothing inductor connected in series between each cascade inverter phase and each phase of the AC power system; and

the control means includes for each cascade inverter phase,
 a first control loop for controlling the power flow to the cascade inverter phase,
 a second feed-back control loop for offsetting the power flow to each of the full bridge inverters of the cascade inverter phase,
 a switching pattern table containing switching timing data for generating the nearly sinusoidal voltage waveform approximation in response to a reference output voltage signal and a desired phase angle for the cascade inverter phase,
 means for calculating the reference output voltage signal for the cascade inverter phase,
 a phase detector for determining a phase reference signal associated with a corresponding phase of the AC system, and
 means for determining the desired phase angle for the cascade inverter phase in response to the phase reference signal and a feedback signal produced by the first and second control loops for the cascade inverter phase.

28. The multiple DC voltage source inverter of claim 27, wherein:

each of said full bridge inverters includes a primary node and a secondary node, each of said full bridge inverters includes a positive node and a negative node, each of said full bridge inverters includes a voltage supporting device electrically connected in a parallel relationship between said positive node and said negative node; and
 each cascade inverter phase includes a plurality of said full bridge inverters, each cascade inverter phase having a consistent number of said full bridge inverters with respect to each phase, each of said full bridge inverters in each cascade inverter phase interconnected in a series relationship with said secondary node of one of said full bridge inverters connected to said primary node of another full bridge inverter, said series interconnection defining a first full bridge inverter and a last full bridge inverter, each phase having an input node at said primary node of said first full bridge inverter and an output node at said secondary node of said last full bridge inverter.

29. The multiple DC voltage source inverter of claim 28, wherein:

the phase shift for each cascade inverter phase is selected to generate a desired level of positive or negative reactive power delivered to the corresponding phase of the AC power system while generating sufficient real power to offset losses incurred within the cascade inverter phase.

30. The multiple DC voltage source inverter of claim 28, wherein:

the phase shift for each cascade inverter phase is selected to perform a flexible AC transmission operation

selected from the group including static VAR generation, power line conditioning, series compensation, phase shifting, voltage balancing, and generator interfacing.

31. The multiple DC voltage source inverter of claim 30 having a plurality of phase connectors, one of said phase connectors electrically connected between said input node of the first of said cascade inverter phases and said output node of the third of said cascade inverter phases, another of said phase connectors electrically connected between said input node of the third of said cascade inverter phases and said output node of the second of said cascade inverter phases, another of said phase connectors electrically connected between said input node of the second of said cascade inverter phases and said output node of the first of said cascade inverter phases.

32. The multiple DC voltage source inverter of claim 30, further comprising each of said full bridge inverters having a first switching pair and a second switching pair, each of said switching pairs having a plurality of switching means for controllably regulating electrical current flow, each of said switching means having a first end and a second end, said first switching pair having a plurality of switching means electrically connected at said first end at said positive node of said full bridge inverter, said second end of one of said switching means of said first switching pair electrically connected to said primary node, said second end of another of said switching means of said first switching pair electrically connected to said secondary node, said second switching pair having a plurality of switching means electrically connected at said second ends at said negative node of said full bridge inverter, said first end of one of said switching means of said second switching pair electrically connected to said primary node, said first end of another of said switching means of said second switching pair electrically connected to said secondary node.

33. The multiple DC voltage source inverter of claim 32, wherein said switching means comprises a gate turn-off device and an anti-parallel device connected in parallel and oppositely biased with respect to one another.

34. The multiple DC voltage source inverter of claim 33, wherein said gate turn-off device is a component selected from the group consisting of a gate turn-off thyristor, an insulated gate bipolar transistor, a power MOSFET, a MOSFET controlled thyristor, a bipolar junction transistor, a static induction transistor, a static induction thyristor and a MOSFET turn-off thyristor.

35. The multiple DC voltage source inverter of claim 34, wherein said anti-parallel device is a diode.

36. The multiple DC voltage source inverter of claim 35, wherein each of said voltage supporting devices is a component selected from the group consisting of capacitors, fuel cells, photovoltaic cells and biomass cells.

* * * * *