

May 2, 1961

G. E. BEIDERWELL

2,982,491

REEL FOR DISPENSING TIE WIRES

Filed Sept. 22, 1958

2 Sheets-Sheet 1

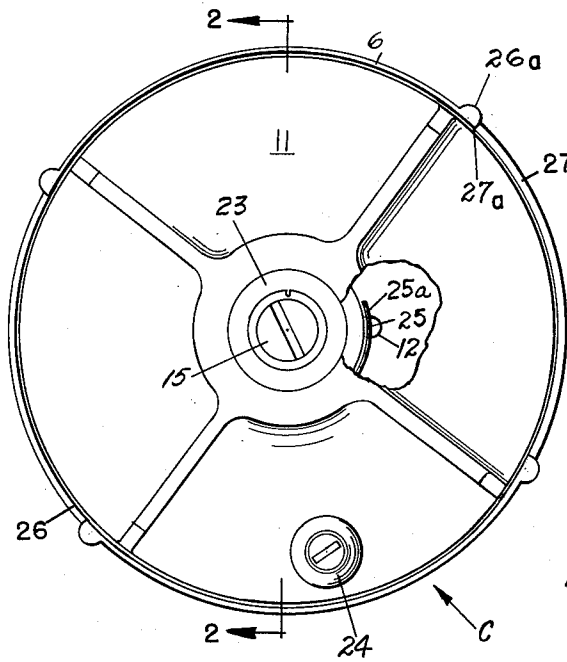

FIG. 1.

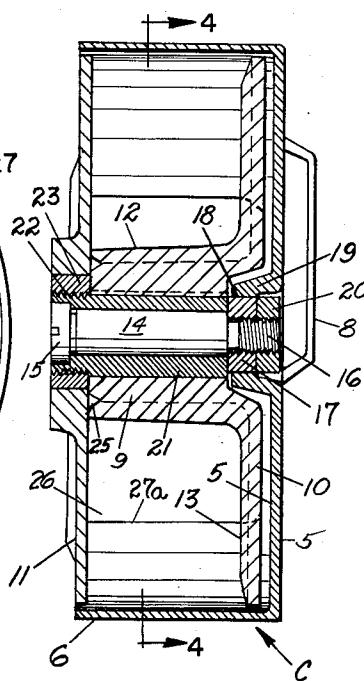

FIG. 2.

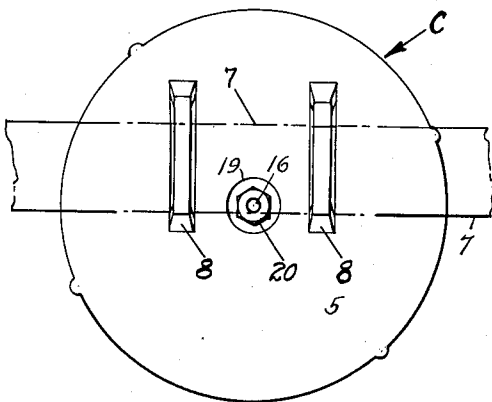

FIG. 3.

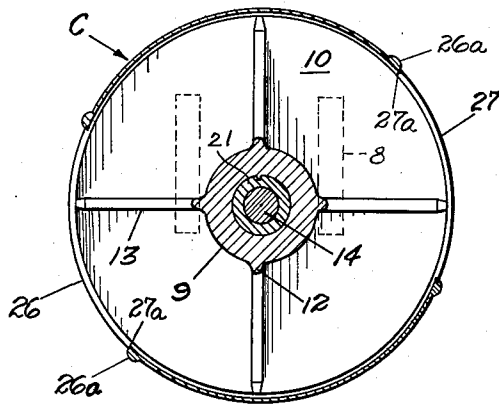

FIG. 4.

INVENTOR.
GEORGE E. BIEDERWELL

BY *Shepard Campbell*

ATTORNEYS

May 2, 1961

G. E. BEIDERWELL

2,982,491

REEL FOR DISPENSING TIE WIRES

Filed Sept. 22, 1958

2 Sheets-Sheet 2

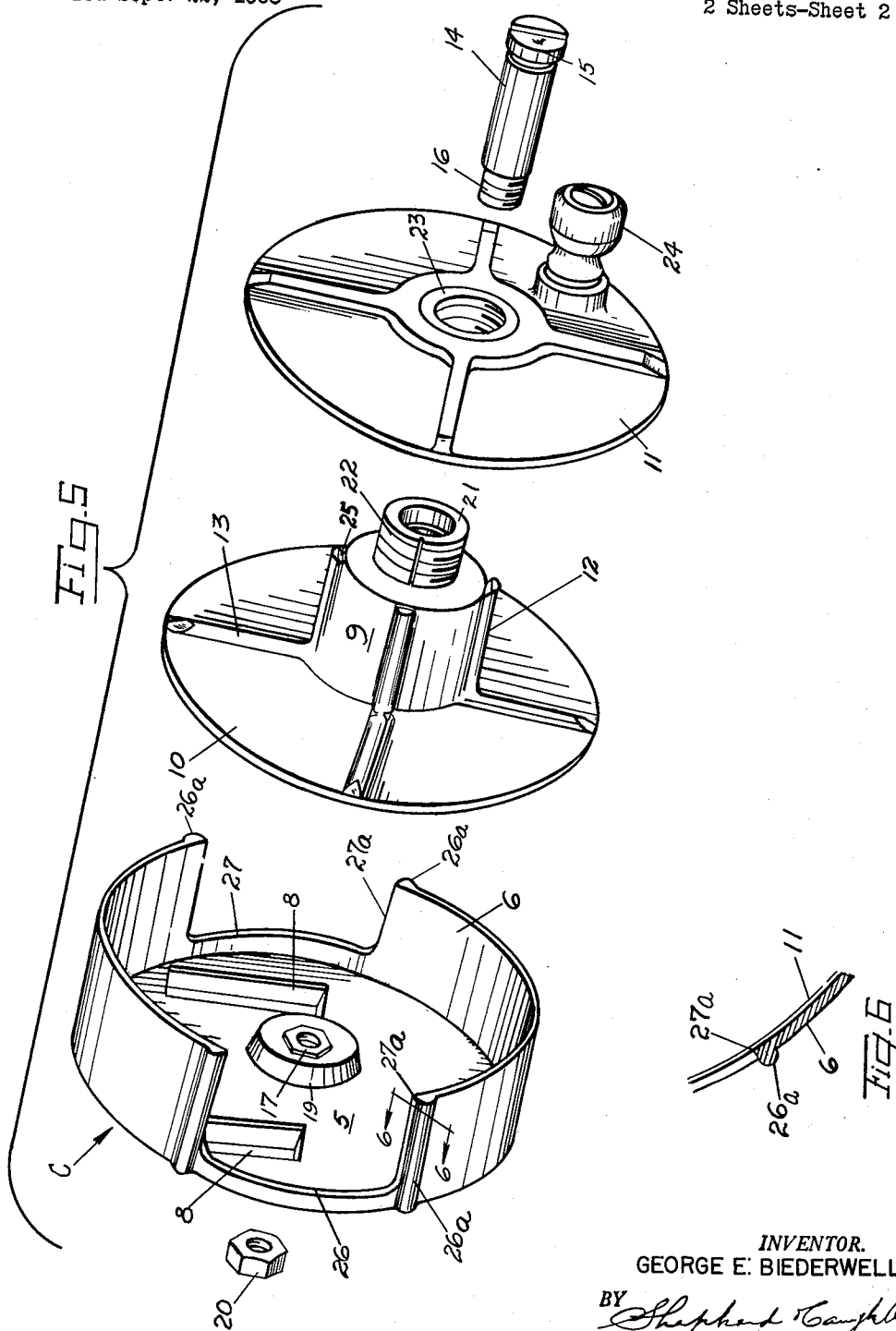

INVENTOR.
GEORGE E. BIEDERWELL
BY *Shepherd Caffell*

AT TORNEYS

1

2,982,491

REEL FOR DISPENSING TIE WIRES

George E. Beiderwell, 328 Harahan Blvd., Paducah, Ky.

Filed Sept. 22, 1958, Ser. No. 762,619

5 Claims. (Cl. 242-96)

This invention relates to tie wire dispensing reels of the character of those shown in my Patent 2,683,000 issued July 6, 1954 and in the Sato Patents Nos. 1,990,135 and 2,542,580, issued on February 5, 1935, and February 20, 1951, respectively.

The object of the present invention is to provide a reel of the character indicated which will be of very light weight but so strong as to have a long life under the strains imposed upon it in use; one in which the wire carrying spool or reel will rotate easily and without undue friction; one in which the tie wire may be withdrawn with equal facility by either right or left-handed persons; one in which the roll of tie wire is so positively engaged with the spool that over running of the wire is effectively prevented; one in which jamming of the wire between the casing and the spool flanges is guarded against and one in which the point of suspension of the whole structure upon the body embracing belt of the user is such as to cause the weight of the whole structure to tend to swing toward the body of the user and thereby to prevent rocking of the casing with respect to the belt, under the action of withdrawing the wire, it being understood that the user pulls with one hand and from a coil of wire disposed within the casing, a sufficient length of wire to constitute a tie and then clips off such portion with a pair of pliers, held in the other hand of the user.

The way in which the desired objects are achieved will be best understood by reference to the accompanying drawings, wherein:

Figure 1 is a face view of a device constructed in accordance with the invention.

Figure 2 is a vertical section on line 2-2 of Figure 1.

Figure 3 is a rear view of the device.

Figure 4 is a vertical sectional view on line 4-4 of Figure 2.

Figure 5 is an exploded perspective view.

Figure 6 is a detail sectional view illustrating the formation of the lip of the casing, over which the wire is pulled out.

Like numerals designate corresponding parts in all of the figures of the drawings.

The device of the invention comprises a casing C consisting of a relatively flat rear wall 5 and a circular peripheral wall 6, that side of the casing opposite wall 5 being open for the insertion of the reel or spool, hereinafter referred to as the reel, and which reel receives a preformed coil of tie wire. The whole structure is, in use, suspended upon a body embracing element such as belt 7 that is worn by the workman. Any suitable means may be employed for suspending the structure upon belt 7. The means herein shown consists of a pair of loops 8 which project from the rear side of the casing and are preferably so located above the center of the structure as to suspend the casing in a manner to cause it to tend to swing toward and against the body of the user.

The reel proper comprises a central core or hub 9, a flange 10 that is integral with the core and a removable

2

front flange 11. The core 9 carries a plurality of ribs 12 extending lengthwise along its outer surface and the rear flange 10 may also be provided with strengthening ribs 13 upon its inner face.

5 The casing C, the core 9, the inner flange 10, and the removable front flange 11, together with the loops 8, are all made of aluminum or other light weight material for the purpose of rendering the structure as light in weight, as possible. This is of importance in a structure which must be worn by a workman, through consecutive hours of labor. The wire that is to be dispensed and which, in forming a tie, must be twisted, is usually of relatively soft iron and such a coil of wire is necessarily of a very appreciable weight. It is, therefore, desirable to offset this weight of the wire coil by making the dispensing structure as light in weight as possible. However, the use of aluminum, magnesium or other light weight material is accompanied by the disadvantage that these materials do not offer the same strength and wear resistance that are offered by such metals as iron, steel and brass.

In mounting the reel for rotation, in, and with respect to the casing, a central arbor 14, comprising a head 15 and threaded inner end 16, is engaged with the casing C by screwing its threaded inner end into a hard metal, nut like element 17, which is forced into a correspondingly shaped opening in the vertical wall 18 which constitutes the inner face of a cup like indented member 19, formed integrally with the rear wall 5 of the casing. The threaded end portion of the arbor 14 projects beyond the nut like element 17, far enough to receive a retaining and lock nut 20, and when the arbor is screwed into the nut like element and the retaining nut is applied, the arbor is rigidly affixed to the casing. The retaining nut 20 lies within the cup like indentation 19 and thus lies in a position where it does not contact the body of the user, nor cause any discomfort during long periods of use of the structure.

A, preferably, brass bushing 21 is cast in the hub or core of the reel and constitutes the bearing element of the reel upon the arbor. A threaded extension 22 of this bushing receives a correspondingly threaded washer like ring 23 of a hard metal, such as iron or steel, said ring being cast into a central opening of the removable front flange 11. The threaded engagement described between the reel hub and the removable front flange, is preferably a left-handed one, whereby when it is desired to wind any withdrawn wire back into the casing, rotation of the front flange by means of the handle 24 will tend to tighten said front flange rather than loosen it. The hub of the reel 9 and the ribs 12 on the surface thereof preferably present a structure which tapers slightly from the rear flange 10 toward the front flange. The front ends of the ribs 12, against which the front flange abuts when said flange is screwed all the way home are provided with transversely extending notches 25, into any one of which the inner terminal end 25a of the coil of wire, may be inserted, thus ensuring that the coil of wire as a whole, can not turn with respect to the reel but must turn with the reel. Thus any possibility of over-running of the wire, and entanglement thereof, is prevented. The inner end of the brass bushing 21, bears upon the inner face of the hard metal fixed nut 17, the inner face of said nut being extended inwardly beyond the plane of the vertical wall 18 of the indentation 19, to such an extent that the rotative contact between the reel and the casing is that afforded by the contact of the inner end of the brass bushing with the face of the hard metal, nut like member. Thus it will be seen that there is no rotative contact between any aluminum part of the reel with an aluminum part of the casing C. The structure may be much more econom-

ically manufactured by forcing an ordinary hard metal nut into the inner vertical wall 18 of the indentation 19, than by threading said vertical wall for the reception of arbor 14. This is so because in order to so thread said wall for the arbor it would be necessary to chuck and center the casing C in a screw cutting machine. Further the aluminum casing lacks the strength for such threading. A more important point is that by forcing a hard metal nut 17 into place, as described with its inner face projecting inwardly of the said vertical wall, the end of the relatively soft metal, brass bushing, rotates upon this inwardly projecting face of the nut. Thus all wear is upon the easily replaceable bushing and relatively none upon the casing itself. Nut 17 is thus caused to serve several functions, to wit, its inner face provides a bearing portion upon which the brass bushing rides; its hard metal outer face provides a surface against which the lock nut may impinge and bind in locking the arbor in place and its threaded bore receives the threaded inner end of the arbor 14. Outward movement of the hub of the reel is prevented by the head 15 of the arbor 14.

To permit wire to be withdrawn in either direction, by either right-handed or left-handed workmen the peripheral wall 6 is provided with the openings 26 and 27, and it will be observed that the major portion of the opening 27 lies above the center of the casing while the major portion of the opening 26 lies below the center of the casing. When the reel is being worn upon the right hand side of the workman the wire is withdrawn from the top of the coil of wire and when the reel is worn upon the left hand side, the wire is withdrawn from the lower side of the coil. The reel is worn upon the left side by a right-handed workman, who withdraws the wire with his left hand while with the right hand he manipulates the pliers with which he cuts off the piece that is to be used for the tie. Note that the belt loops are disposed enough above the center of the structure, to suspend the casing in such manner that the pull upon the wire by the workman, tends to swing the casing toward and into contact with the workman's body and that locating one of the withdrawal openings in the peripheral wall, higher than the other opening facilities easy withdrawal of the wire, whether the wire is being withdrawn from the top or from the bottom of the coil on the spool.

It has been the practice to form those edges of the openings, through which the wire is withdrawn, as enlarged and rounded beads, to reduce friction and to receive the wear. However, the formation of these rounded beads has left openings, presenting flaring mouths at the point where the said beads overlie the outer edge of the outer flange 11; with the result that when the handle 24 is manipulated to turn the reel and rewind any of the wire that has been withdrawn, the wire engages in this flaring opening and binds between the casing and the front flange. This causes annoyance to the workman and loss of valuable time in disengaging the trapped wire. To prevent this troublesome action I form the terminal edge of the wall 6 as a wear resisting and friction reducing bead 26a throughout the major portion of the width of the casing, but at the point where said terminal edge lies close to the peripheral edge of the flanges 10 and 11, and especially where it lies close to the outer flange 11, the front face of the bead is extended downward in a straight line to the inner face of the peripheral wall 6. This leaves a relatively sharp edge 27a at that point, which lies in such close proximity to the peripheral edge of the flange as to prevent the entry of the wire between casing and flange, at that point.

While I have described the belt engaging means as constituting spaced loops 8, it is clear that the same result could be achieved by increasing the width of the loops toward each other, until the belt engaging surface presented is a substantially continuous one.

It is to be understood that the invention is not limited to the precise construction set forth but that it includes within its purview whatever changes fairly fall within either the terms or the spirit of the appended claims.

I claim:

1. A structure of the character described comprising a cup like casing consisting of a vertical rear wall and a circular peripheral wall, said rear wall having a central indented cup like portion, the inner end of which presents a vertical wall having a fixed threaded nut like element embedded therein, with the inner face of the nut like element projecting beyond the inner face of the cup like indentation, an arbor lying perpendicular with respect to the rear wall of the casing and having an inner end threaded in said nut like member, a reel constructed to receive a coil of wire to be dispensed, said reel comprising a hub, an inner flange and a removable outer flange, said hub carrying in fixed relationship thereto an internal wear resisting bushing which embraces and rides upon said arbor and the inner end of which bears and rides upon the projecting face of said fixed nut like member.

2. A structure as recited in claim 1 wherein the length of the arbor is such that its inner end extends beyond said nut like member and into the interior of the cup like indentation of the rear wall of the casing and a retaining nut threaded upon the said inner end of the arbor, which nut lies wholly within the confines of the indented cup like portion of the rear wall and which impinges upon the outer face of the nut like element.

3. A structure as recited in claim 1, wherein the forward end of said bushing is threaded and wherein the removable front flange of the reel is screwed upon said threaded portion.

4. A device of the character described comprising a cup like casing consisting of a substantially plane rear wall and a forwardly projecting circular peripheral wall, said peripheral wall being provided with a wire withdrawal opening at each side thereof, said rear wall of the casing being provided with a forwardly projecting centrally disposed cup like indentation, a hard metal nut like member rigidly affixed in the inner end of the said forwardly projecting indentation, with the inner face of the said nut like member projecting inwardly beyond the plane of the inner face of said indentation, an arbor threaded into said fixed nut like member and extending materially beyond said nut like member to provide a portion lying within said indentation of the casing, a retaining and lock nut disposed wholly within said indentation and threaded upon the inner end of said arbor, a headed front end member upon that end of the arbor remote from said indentation, a reel comprising a hub, an integral inner flange and a removable outer flange, a bearing bushing fixed to said hub, the ends of which bear between the inner face of the fixed nut like member and the head forming portion of the arbor.

5. A structure as recited in claim 4 wherein said bushing carries a left-hand thread and wherein the removable flange of the reel carries a correspondingly threaded central portion for engagement with such threads and a handle upon the removable flange for rotating the same, said threads being of left-handed formation so that when the handle is manipulated to return the reel in a direction to wind surplus wire back into the casing, the threads will tighten the removable flange upon the hub.

References Cited in the file of this patent

UNITED STATES PATENTS

606,666	Hubner	July 5, 1898
1,593,012	Bryant	July 20, 1926
2,249,114	Coffman	July 15, 1941
2,542,580	Sato	Feb. 20, 1951
2,683,000	Beiderwell	July 6, 1954