

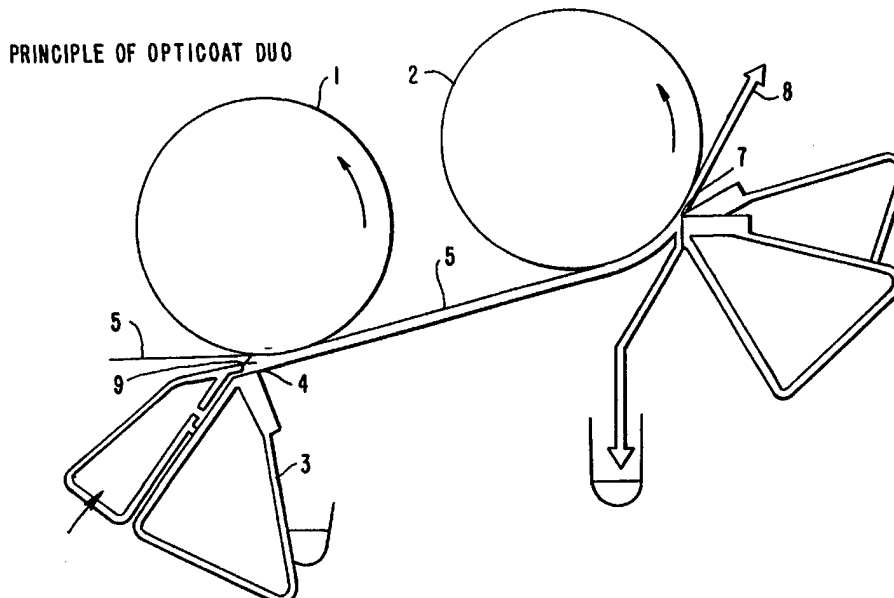

INTERNATIONAL APPLICATION PUBLISHED UNDER THE PATENT COOPERATION TREATY (PCT)

| | | |
|---|---|--|
| <p>(51) International Patent Classification ⁶ : B05D 3/12, B05C 11/04</p> | <p>A1</p> | <p>(11) International Publication Number: WO 98/50169</p> <p>(43) International Publication Date: 12 November 1998 (12.11.98)</p> |
| <p>(21) International Application Number: PCT/US98/09314</p> <p>(22) International Filing Date: 7 May 1998 (07.05.98)</p> <p>(30) Priority Data: 60/046,134 9 May 1997 (09.05.97) US</p> <p>(71) Applicant (for all designated States except US): VALMET CORPORATION [FI/FI]; Panuntie 6, FIN-00620 Helsinki (FI).</p> <p>(72) Inventors; and (75) Inventors/Applicants (for US only): LEINO, Mika [FI/FI]; Jenkkapolku 20 B, FIN-04420 Järvenpää (FI). RENVALL, Stig [FI/US]; 3030 Rea Road, Charlotte, NC 28226 (US). KUNI, Stefan [FI/FI]; Pietolankatu 15, FIN-04400 Järvenpää (FI). PALOVIITA, Petri [FI/US]; W3175 Cornell Court, Appleton, WI 54915 (US).</p> <p>(74) Agent: STUART, Michael, C.; Cohen, Pontani, Lieberman & Pavane, Suite 1210, 551 Fifth Avenue, New York, NY 10176 (US).</p> | <p>(81) Designated States: AL, AM, AT, AU, AZ, BA, BB, BG, BR, BY, CA, CH, CN, CU, CZ, DE, DK, EE, ES, FI, GB, GE, HU, IL, IS, JP, KE, KG, KP, KR, KZ, LC, LK, LR, LS, LT, LU, LV, MD, MG, MK, MN, MW, MX, NO, NZ, PL, PT, RO, RU, SD, SE, SG, SI, SK, TJ, TM, TR, TT, UA, UG, US, UZ, VN, ARIPO patent (GH, GM, KE, LS, MW, SD, SZ, UG, ZW), Eurasian patent (AM, AZ, BY, KG, KZ, MD, RU, TJ, TM), European patent (AT, BE, CH, CY, DE, DK, ES, FI, FR, GB, GR, IE, IT, LU, MC, NL, PT, SE), OAPI patent (BF, BJ, CF, CG, CI, CM, GA, GN, ML, MR, NE, SN, TD, TG).</p> <p>Published With international search report.</p> | |

(54) Title: METHOD AND APPARATUS FOR COATING PAPER BOARD AND PAPER



(57) Abstract

A method and apparatus for coating a paper or a paper board web (5), comprising spreading coating mix having a solids content of 55 to 75 % on the surface of the web (5) with a nozzle applicator (3, 9), levelling and metering the spread coating mix on the surface of the web by a doctor element (7) capable of producing a high hydrodynamic force on the contacting layer between the doctor element (7) and the web (5), the doctor element (7) being located downstream of the applicator (3, 9) so that the dwell time between the spreading of the coating mix to the metering is 72-2400 ms. The web speed is preferably 100-1000 m/s. A good smoothness and coverage is achieved by this method due to long dwell time.

FOR THE PURPOSES OF INFORMATION ONLY

Codes used to identify States party to the PCT on the front pages of pamphlets publishing international applications under the PCT.

| | | | | | | | |
|----|--------------------------|----|--|----|--|----|--------------------------|
| AL | Albania | ES | Spain | LS | Lesotho | SI | Slovenia |
| AM | Armenia | FI | Finland | LT | Lithuania | SK | Slovakia |
| AT | Austria | FR | France | LU | Luxembourg | SN | Senegal |
| AU | Australia | GA | Gabon | LV | Latvia | SZ | Swaziland |
| AZ | Azerbaijan | GB | United Kingdom | MC | Monaco | TD | Chad |
| BA | Bosnia and Herzegovina | GE | Georgia | MD | Republic of Moldova | TG | Togo |
| BB | Barbados | GH | Ghana | MG | Madagascar | TJ | Tajikistan |
| BE | Belgium | GN | Guinea | MK | The former Yugoslav Republic of Macedonia | TM | Turkmenistan |
| BF | Burkina Faso | GR | Greece | | | TR | Turkey |
| BG | Bulgaria | HU | Hungary | ML | Mali | TT | Trinidad and Tobago |
| BJ | Benin | IE | Ireland | MN | Mongolia | UA | Ukraine |
| BR | Brazil | IL | Israel | MR | Mauritania | UG | Uganda |
| BY | Belarus | IS | Iceland | MW | Malawi | US | United States of America |
| CA | Canada | IT | Italy | MX | Mexico | UZ | Uzbekistan |
| CF | Central African Republic | JP | Japan | NE | Niger | VN | Viet Nam |
| CG | Congo | KE | Kenya | NL | Netherlands | YU | Yugoslavia |
| CH | Switzerland | KG | Kyrgyzstan | NO | Norway | ZW | Zimbabwe |
| CI | Côte d'Ivoire | KP | Democratic People's Republic of Korea | NZ | New Zealand | | |
| CM | Cameroon | | | PL | Poland | | |
| CN | China | KR | Republic of Korea | PT | Portugal | | |
| CU | Cuba | KZ | Kazakstan | RO | Romania | | |
| CZ | Czech Republic | LC | Saint Lucia | RU | Russian Federation | | |
| DE | Germany | LI | Liechtenstein | SD | Sudan | | |
| DK | Denmark | LK | Sri Lanka | SE | Sweden | | |
| EE | Estonia | LR | Liberia | SG | Singapore | | |

Method and apparatus for coating paper board and paper

5 The present invention relates to coating of paper and especially paper board with high-viscosity coating mixes in order to achieve good coverage together with good smoothness of the coating layer.

Background of the invention

In paper board coating the operating speeds are increasing since productivity claims are getting constantly higher. This concerns also coating of paper. Very often a good coverage of the coated layer is of great importance for the quality of the final product. The coverage effects many quality properties of the final product such as gloss uniformity, uniform ink absorption, good and uniform brightness etc. The coverage is of extreme importance in coating of webs having low brightness such as cardboard or paper grades that have not been bleached in full and some grades where recycled fibers and low intensity bleaching are used.

An excellent device for producing such a coatings is an air knife coater. In this apparatus the coating mix is spread on a moving web with an applicator roll or a nozzle applicator and the excess coating is scraped away with a thin air jet blown from an air knife. These apparatuses are well known in paper and board manufacturing. At present, the air knife is a bottleneck of the coating process due to its limited capacity to operate on high speed required in modern processes. The air knife requires regular cleaning which leads to down time, the coating color solids are limited to 40 - 50% and the smoothness of the final product is poor according to present standards. The air knife also takes a lot of space in the lay-out, it is noisy and a lot of coating mix mist is entrained in the exhaust air causing cleaning problems. A typical problem relating to the quality of the final product in air knife coating is poor smoothness of the coating surface caused by the contour type coverage.

In air knife coating, there is a determinable dwell time between the application of the coating mix and the air knife doctoring. During this dwell time, a settled coating

layer is formed on the web to be coated and the excess free coating is blown away from the web by the air knife. The coating layer left on the web is contoured according to the form of the web surface and the coating layer has thus a very uniform thickness. Also the coat weights are normally high (8 - 22 g/m²) The blow off capacity of the air doctor limits the operation range of the coating apparatus to typical solids content of mineral coating mixes of 25 - 55% and to web speeds of 50 - 600 m/s.

10

A contoured type coverage can be achieved also with a film transfer coating apparatus. In such an apparatus the coating film is first made on a rotating roll and then transferred onto the surface of a web travelling on the film transfer roll. Film transfer coaters can operate on speeds up to 2000 m/s and on solids contents up to 70%. However, film transfer apparatuses are not capable of producing high coat weights. Typical upper range for coat weight is 10 - 12 g/m². The absorption characteristics of the applicator roll and the web determine the film slit surface after the application nip and this determines the achievable maximum coat weight left on the web after the film split. In addition, the uniformity of the coating left on the web is determined by the absorption characteristics of the web. If the absorption characteristics of the web change, for example due to moisture variation in the machine or cross-machine direction of the web, the quality of the final product may be effected.

30

The air knife coaters and film transfer coaters are not capable of producing as smooth coating as blade coaters which are superior in this aspect.

Summary of the invention

According to the present invention, a coating mix having a solids content of 55 - 75% is spread on the web and the excess coating is doctored from the web by using a high metering pressure and the dwell time between application and doctoring is 72 - 2400 ms.

According to the other aspects of the present invention, the coating is spread on the web with a free nozzle or blade or rod metered nozzle applicator and the coating mix layer is doctored by a rod or a blade doctor operating on a hydrodynamic coating mix film formed on the web.

Further, the backing roll of the doctoring element is a compressible roll that allows deformation of the roll surface under the doctoring device.

Other objects and features of the invention will become apparent from the following detailed description considered in conjunction with the accompanying drawings. It is to be understood, however, that the drawings are intended solely for purposes of illustration and not as a definition of the limits of the invention, for which reference should be made to the appended claims.

Brief description of the drawings

Fig. 1 shows schematically a known air knife coating apparatus.

5

Fig. 2 shows schematically a known film transfer coating apparatus.

Fig. 3 shows schematically an apparatus for implementation of the invention.

10

Fig. 4 shows schematically a free-jet applicator.

Fig. 5 shows schematically a rod metered jet applicator.

15

Fig. 6 shows schematically a blade metered jet applicator.

Fig. 7 is a diagram presenting results of a comparative trial test run.

20

Fig. 8 is a diagram presenting the relation of the coat weight to the tube pressure of a doctor rod.

Fig. 9 is a diagram presenting the relation of the rod pressure to the uniformity fo the coating layer.

25

Fig. 10 is a diagram presenting the smoothness of the coating layer made with different coating methods.

Fig. 11 is a diagram presenting the smoothness of the coating layer made with different coating methods.

30

Fig. 12 is a diagram showing the forces present in the rod doctoring process.

35

Figures 13 - 17 show test results of pilot trials.

Detailed description of the presently preferred embodiments

Apparatuses described in figures 1 and 2 are well known in the art of paper and paper board manufacturing and they are shown here only as illustrations of presently used coating methods described above. Hence no detailed description of these apparatuses is included here.

Figure 3 shows a coating apparatus suitable for implementation of the invention. This apparatus includes two backing rolls 1, 2, an applicator apparatus 3 adapted to operate together with the first backing roll 1 and a doctoring means 7 operating with the second backing roll 2. The doctoring means may be a blade, or a smooth or a grooved rod. The web 5 to be coated is directed to the first backing roll 1 and it runs between the applicator apparatus 3 and the backing roll 1. The applicator apparatus 3 comprises a nozzle 9 extending over the web in cross direction for feeding a coating mix on the web 5. The amount of spread coating mix is controlled with a presmoothing blade 4 that is pressed against the web 5. When coating mix is pumped from the nozzle 9 it is levelled and metered on the web 5 by the presmoothing blade 4 whereby a coating layer 6 attaches on the web 5. Next the web 5 arrives to the second backing roll 2 and runs between the roll 2 and the doctoring means 7. The doctoring means meters and levels the coating layer on its final thickness leaving a final coating layer 8 on the web.

Figures 4, 5 and 6 show differences of free, blade metered and rod metered nozzle applicators. In a nozzle applicator the coating mix is spread on the web simply by injecting it through a nozzle and all of the injected coating mix is attached to the web. In a blade or rod metered applicator an outgoing slot is formed between the web and the pre-metering means and the amount of the coating mix adhered

on the web is determined by the premetering force and the width of the slot. All of these applicators are familiar to a person skilled in the art of coating moving paper material webs and more detailed description of these may therefore be omitted. Nozzle applicators are preferred in this method because of their short and low-pressure application impulse whereby the penetration of coating mix and water on the web during the application is minimum.

10 The invention may be implemented with different kinds of application and doctoring means. According to the invention, a good smoothness is achieved by using relatively long dwell time between application of the coating mix and final metering or levelling of the coating layer. The long dwell
15 time gives the web time to swell to its equilibrium state when water phase of the coating mix is absorbed into the web. This preswelling of the fibers of the web before doctoring ensures that no or a minimum amount of swelling occurs after doctoring whereby the swelling fibers do not
20 affect the thickness or smoothness of the final coating layer. Therefore no or little roughening occurs after the final metering which guarantees good end smoothness.

A good coverage is ensured by so called contour coating
25 wherein the thickness of the coating layer on the surface form of the web is uniform. Normally, this kind of surface layer would lead to decrease of the smoothness, but because of fibre preswelling and a special kind of doctoring, a good coverage can be combined. Sufficient thickness is
30 achieved by utilizing relatively high hydrodynamic pressure under the metering element. High pressure is achieved by using a long dwell time, high-shear viscosity of the partially settled coating layer having also a high initial solids content. If shorter dwell times or lower solids
35 contents were used, the metering element would scrape all or almost all coating mix of the web if high doctoring

forces were used. The high metering pressure compresses the web and the backing roll during metering making it possible to create a thick coating film between the web and the doctoring element that has even thickness. Because of the compression of the web and the backing roll, the contour type coating layer formed is better or close to the contour coatings achieved with air doctor coating devices, for example in regard of coverage and smoothness.

10 The main factors effecting the coating process according to the invention are composition of the coating mix, especially the solids content, application pressure, amount of the applied coating, dwell time, dewatering of the coating mix after application, viscosity of the coating mix during
15 metering, metering pressure, compressibility of the web and the backing roll and the diameter of the metering element when a doctor rod is used.

The coating mix used may be water dispersion of mineral coating materials, binders and additives. Typical solids content of the coating mix used is 55 - 75%. The coating mix is applied on the web with a nozzle applicator unit which may be a free jet applicator, a blade metered applicator or a rod metered applicator. The backing element of
25 the applicator may be a compressible or non-compressible roll or a shoe or similar backing element. The coating mix is metered by a metering rod, which may be grooved or smooth, or a doctoring blade. The rod is preferably rotated and the doctor blade is a small angle blade (bent blade)
30 wherein a hydrodynamic foil is formed under the blade. In trial tests of the invention, better coverage was achieved with a doctoring rod and better smoothness with a blade doctor. The backing element of the doctor element is preferably a compressible roll, but for example shoe or other
35 backing elements may be used. On thicker and compressible grades a non-compressible backing element may be used in

special conditions.

The dwell time plays an important role on the coverage and smoothness of the final coating layer. The distance between the application unit and the metering unit determines the dwell time between application and doctoring if the web speed does not change and this distance may vary between 1200 - 4000 mm. In the web speed range of 100 - 1000 m/min the dwell time is between 72 - 2400 ms. With a longer dwell time it may be expected, that

- more dewatering of the coating mix occurs before metering,
- fiber swelling before metering increases,
- a thicker semi-solidified settled layer (filter cake) is built on the web.

As result of these factors it may be expected, that

- higher metering pressure is required to achieve certain final coat weight (better coverage),
- the portion of the settled coating forming a contoured filter cake on the web increases (better coverage),
- the roughening after metering is minimized.

In order to achieve long dwell distance and time, two backing elements are preferably used. However, it is possible to use a large single backing roll if the dwell distance can made longer than 1200 mm. In this case, the backing roll is preferably compressibile. Of course, the dwell distance can be made adjustable.

One important aspect of the invention is the use of a high doctoring force enabled by the high initial solids content of the coating mix and the long dwell time. In this con-

text, the doctoring force should be equal or higher than the force under a smooth rotating doctoring rod having a diameter of 12 mm with a 1.2 bar tube pressure applied on the back side of the rod bed. This force is 1.0 kN/m.

5

The doctoring force F_M for a smooth rod can be determined as a sum of mechanical contact force F_0 , the impulse force from the coating mix on the doctor rod F_1 and the hydrodynamic force F_H . These forces are shown in figure 12.

10

$$(1) \quad F_M = F_0 + F_1 + F_H$$

F_0 is assumed to be zero as it is assumed that a film of coating exist constantly between the web and the rod.

15

$$(2) \quad F_1 = \{m \times v (1 + \cos\theta)\} / \sin\theta$$

m = applied amount of coating

v = speed

20

θ = angle between metering element and the web, dependent on the metering element (rod diameter, blade) and compressibility of the backing roll and the web

25

$$(3) \quad F_H = (6 \times \eta \times v) / \tan^2\theta (\ln(1+k) - 2k/(2+k))$$

η = viscosity at applied shear

k = $h_1/h_0 - 1$

h_1 = thickness of the applied coating layer at the point where the hydrodynamic force starts to effect

30

h_0 = coating thickness under the doctoring element

The preferable operating conditions of the invention are

35

Application pressure: from zero upwards

Amount of applied coating: 30 - 800 g/m²
Viscosity during metering: 80-140 mPas measured in
a capillary viscosimeter at 200 000-650 000
1/s shear rate
5 Doctoring force: at least 1.0 kN/m
 Doctored red coat weight: 8 - 25 g/m²

10 The benefits of the invention are presented in following
with reference to pilot trials.

The figure 7 shows that increased dwell time gives better
coverage with constant coat weight. The coverage measure-
15 ment was done by a laser ablation method developed by the
University of Jyväskylä, Finland. In this figure, the first
column on right shows the coverage obtained with an impro-
ved SDTA (short dwell time applicator) and second with a
roll applicator coater. The dwell distance in SDTA is 60 mm
20 and the coverage is the worst. In roll applicator the dwell
distance is 600 mm, but the application pressure is much
higher than in other coaters and the coating mix is penet-
rated more into the base material web. When three columns
on the left are viewed, it can be seen, that coverage is
25 better when dwell distance is increased. Dwell distance is
shown under the columns. All trial points have been run
with same kind of application and metering and the only
variable is the dwell time.

30 The effect of the dwell time on the thickness of the final
coating layer and the doctoring pressure is shown in figure
8. The trials were run with a rotating doctor bar having
diameter of 12 mm. It can be seen that the coat weight is
about 3 g/m² higher on dwell distance of 1600 mm than on
35 distance of 450 mm.

The figure 9 shows the effect of a high metering pressure on visual uniformity. The base board was unbleached carrier board and coating mix consisted of clay, calcium carbonate and titanium oxide pigments. The visual uniformity was assessed by a professional panel, and clear result was that the higher the metering pressure, the better the visual uniformity. The dwell distance was 1600 mm.

The increase of smoothness due to long dwell time can be seen in figures 10 and 11 which show PPS-s10 and Bendtsen smoothness of a second coating of white lined chipboard. AB-r is an application roll coater with rod metering (dwell distance 600 mm) and Ocj-r is a jet coater with rod metering (dwell 450 mm) and OCDJ-r is a jet coater with rod metering and long dwell distance (1600 mm). Long dwell time gives best smoothness with both methods.

The Pilot Coater Trials

The effects of the application method, dwell time and metering method on coated board properties were investigated on a pilot scale. The variables in the pilot coater were the application method, including premetered nozzle application (Figure 6), open jet fountain applicator (Figure 4) and application roll, the dwell distance, which was from 450 mm to 1600 mm, rod diameter, and rod or blade metering.

Two pilot trials were made. In the first trial, pre, mid and top coatings were investigated. In the second trial, precoating was made with application roll and only mid and top coatings were investigated.

The coating head comparisons in the pilot trials were run at a speed of 400 m/min, as it is a typical production speed today. However, there is practically no speed limitation in rod coating. The lowest speed run was 100 m/min and

the highest 1000 m/min. There were no runnability problems in this speed range, giving for a long dwell time rod coater much better runnability than for an airknife.

5 The coating heads used in the trial are shown in Table 1, and the coating mix formulations used in the pilot trials in Table 2.

Table 1. The coating heads used in the pilot trials.

| 10 | APPLICATION METHOD | DWELL DISTANCE | METERING METHOD | ABBREVIATION |
|----|--------------------|-----------------|-----------------|--------------|
| | Application roll | Normal (600 mm) | blade | AR |
| | Application roll | Normal (600 mm) | rod | AR-r |
| 15 | Premetered nozzle | Normal (800 mm) | airknife | AK |
| | Premetered nozzle | Long (1600 mm) | blade | LP |
| 20 | Premetered nozzle | Long (1600 mm) | rod | LP-r |
| | Free jet | Normal (450 mm) | rod | J-r |
| | Free jet | Long (1600 mm) | blade | LJ |
| | Free jet | Long (1600 mm) | rod | LJ-r |
| 25 | | | | |

Table 2. Coating mix formulations in pilot trials.

| | PRE COATING (color 1) | MID COATING (color 2) | TOP COATING (color 3) |
|------------------|-----------------------|-----------------------|-----------------------|
| American clay #2 | 50 | | |

| | PRE COATING (color 1) | MID COATING (color 2) | TOP COATING (color 3) |
|---------------------------------------|--------------------------|--------------------------|--------------------------|
| American clay #1 | | 52 | |
| Delaminated clay | 25 | | |
| 5 Structurized clay | 25 | | |
| Calcined clay | | | 52 |
| 10 Ground cal- cium car- bonate | | 15 | 15 |
| Titanium dio- xide | | 33 | 33 |
| PVAC-latex | 17 | 17 | 17 |
| CMC | 0.5 | | 0.8 |
| 15 Polyvinyl alcohol | | 1.5* | |
| Solids, % | 62 | 62* | 60 |
| pH | 8.5 | 8.5 | 8.5 |

* On AK, 1.5 parts protein was used instead of PVOH. Solids
20 on AK was 48 %

The board was dried after every coating layer using an
infrared dryer (ca 100 kW) and 4 air foils. The air veloci-
25 ty in foils was 25 m/s, at a temperature of 120 to 180°C.

The base board was a carrier board base, pre-calendered by
a wet stack. The target total coat weight was 35 g/m²,
comprising pre coating 8 g/m², mid coating 18 g/m² and top
30 coating 9 g/m². Final calendering was not carried out.

30

Rod Parameters and Some Trial Results

The traditional way to control coat weight in smooth rod metering is by means of the coating mix solids and rod pressure. Maximum runnable solids and viscosity levels frequently have to be used. In conventional rod coating,
5 the coat weight control area is more limited than with blade.

It has been reported that relatively high metering pressure causes web compression during metering with a small angle
10 blade. After the blade nip, the web structure recovers to some extent. As a result, the coating layer has been formed to be more contour-like. The situation described here has certain similarities with smooth rod metering at a high load.

15 Visual observations made during several trials indicate that a high rod metering pressure (1.5-2.0 bar) establishes a very even and highly opaque surface with less cloudiness than at a lower pressure. There is some evidence that when
20 the diameter of the rod increases, the board will be rougher, but the effect is minor. The rotation speed of the rod (50-350 r/min) did not affect the quality of the board.

The trial results also confirmed that extremely high coat
25 weights (10-20 g/m²) can be reached with only single coating pass and rod metering by using a coating mix containing eminently high-shear viscosity properties (PVOH).

Some trials were also executed using dwell time between
30 application and metering as a variable. A clear dependence between longer dwell time and higher coat weight was seen. Nevertheless, the effect of dwell time on coat weight often depends on the properties of the base sheet (porosity, absorption). The coat weight is usually 2-5 g/m² higher at
35 a long dwell time. Board properties such as smoothness, gloss and visual uniformity were also improved by a long

dwelt time. The excessive drying of the coating mix before metering was not a problem.

Board Properties

5

The basic board properties discussed are PPS-s10 smoothness and Hunter gloss. Coverage is discussed too. A professional panel, which estimated the visual uniformity of the board sample, was used to evaluate coverage.

10

First trial.

Several coating head combinations were used in this trial. The smoothness level after precoating varied from 3.2 to 4.6 um. In blade precoating, premetered nozzle application gave 0.3-0.5 um better PPS-s10 smoothness than free jet application. There was no difference in appearance or coverage after precoating. After triple coating, there was still a 0.2-0.3 um difference in the smoothness of premetered nozzle and jet application in precoating.

20

It is beneficial to precoat with a blade. Blade precoating gives a very smooth surface. The PPS-s10 difference between blade and rod metering is 0.8-1.1 um. If blade coating is carried out on a brown base board, the visual appearance is much worse than after rod metering. There is a great deal of coating color in the valleys of the surface, but the hills are almost uncovered. When a stiff blade is used, the phenomenon of a bent blade giving greater contour pre-coating is emphasized.

30

After mid coating by rod, the stiff blade precoated sample was the most uniform. The next was bent blade precoated, while the rod precoated was the worst. It is obvious that filter cake formation in the mid coating is convenient after blade precoating. Filter cake formation is then grea-

35

test on the hills of the surface and weakest in the valleys. This is very beneficial to the coverage, and the mottle of the precoating cannot be seen after mid coating. The mid coating layer is the main factor when making coverage, due to the high coat weight and high titanium dioxide content of the coating mix.

There is a slight difference between premetered nozzle and free jet application in mid coating, when the metering is done by a smooth rod. The visual appearance is a little better after the free jet. The PPS-level is about the same.

When the final metering of the coating is performed with a smooth rod, a high rod pressure gives good coverage and surface smoothness.

It can be seen in Figure 13 that in the final product, the premetered nozzle gives 0.3-0.7 um better PPS-s10 smoothness than free jet application, in bent blade metering (cond. 1 vs. 2). If the final metering is done with a smooth rod, the effect of the application method is minor (cond. 3 and 4). The PPS-smoothness is 0.1-0.9 um better after blade metering than after rod metering (cond. 2 vs. 3, cond. 1 vs. 4 and cond. 6 vs. 7).

Figure 14 shows the Hunter-gloss after mid and top coating. The difference between rod and blade in gloss is 3 units after mid coating. The blade mid coated was not visually acceptable. The effect of blade metering is about 10 units in top coating (cond. 2 vs. 3, cond. 1 vs. 4 and cond. 6 vs. 7). The better gloss of blade metering is due to the smoother surface.

Visual appearance was the best, when a combination premetered nozzle applicator with a long dwell time and a blade was used in precoating and top coating, and a long dwell

time jet with a rod in mid coating (cond. 1). The worst was a combination comprising a long dwell time jet with a rod in pre and mid coating and premetered nozzle with a long dwell time and a blade in top coating (cond. 9). Figure 15 also shows the visual uniformities of the samples.

The summary of the first trial is shown in Table 3. The values were measured after top coating.

Table 3. Summary of the first trial.

| Condi- tions | Coating heads | Visual unifor- mity | PPS- s10 | Hunter- gloss | ISO- bright- ness |
|-----------------|--------------------|---------------------------|-------------|------------------|-------------------------|
| 1 | LP+LJ- r+LJ | 4.5 | 2.0 | 49.5 | 85.0 |
| 2 | LP+LJ- r+LP | 5.0 | 1.3 | 56.5 | 84.5 |
| 3 | LP+LJ- r+LP-r | 4.5 | 2.2 | 43.5 | 84.5 |
| 4 | LP+LJ- r+LJ-r | 4.3 | 2.3 | 44.0 | 84.0 |
| 5 | LJ(r)+LJ- r-LP | 5.0 | 1.6 | 54.0 | 85.0 |
| 6 | LJ+LJ- r+LP | 4.9 | 1.6 | 54.0 | 84.5 |
| 7 | LJ+LJ- r+LP-r | 4.8 | 2.7 | 43.0 | 84.0 |
| 8 | LJ-r+LJ- r+LJ-r | 4.6 | 3.3 | 43.5 | 85.0 |
| 9 | LJ-r+LJ- r+LP | 3.3 | 2.9 | 48.0 | 84.5 |

Second trial.

Also in this trial several coating head combinations were used. Precoating was carried out using an application roll
5 coater metered by a stiff blade. The PPS-s10 smoothness was between 4.9-5.5 after precoating (this is about the same level as after free jet application in the first trial). The smoothness after mid and top coatings is shown in Figure 16. The smoothest sample after mid coating was that with
10 roll application and blade metering (cond. 1). The jet application with a long dwell time and rod metering gave almost the same smoothness (cond. 5 and 7). Airknife mid coated samples had the worst smoothness after mid coating (cond. 3 and 6). The smoothness difference between applica-
15 tion roll coater and airknife was 1.1-1.2 um.

In the final product, the sample coated three times with an application roll blade was the smoothest (cond. 1). The PPS-s10 was 1.8 um, but the visual appearance was poorer
20 than that of the rod or airknife mid coated samples. The long dwell time rod coater in mid coating gave a 2.1 um final smoothness, while a normal dwell time rod coater with jet application gave 2.2 um after blade top coating. The final smoothness after airknife mid coating was 2.8 um. An
25 application roll rod top coater was tested on airknife and long dwell time rod coated samples. The rod produced a smoothness 1.2-0.8 um poorer than the blade in top coating (cond. 3 vs. 6 and cond. 5 vs. 7).

30 The Hunter-gloss of the samples was measured after mid and top coating. Figure 17 shows the glosses. The best gloss after mid coat was in the applicator roll blade coated sample, 28 % (cond. 1). There were no big gloss differences between coaters after mid coating. The worst gloss was
35 measured in the airknife coated roll (cond. 3), 24.5 %, though another airknife mid coated roll (cond. 6) was 27 %.

The summary of the first trial is shown in table 4.

Table 4. Summary of the second trial.

| Condi- tions | Coating heads | Visual uniformi- ty | PPS- s10 | Hunter- gloss | ISO- bright- ness |
|-----------------|------------------|---------------------------|-------------|------------------|-------------------------|
| 1 | AR+AR+AR | 4.1 | 1.9 | 53.5 | 84.5 |
| 2 | AR+AR- r+AR | 4.2 | 2.2 | 52.0 | 85.0 |
| 3 | AR+AK+AR | 4.3 | 2.8 | 48.0 | 83.5 |
| 4 | AR-J-r+AR | 4.2 | 2.2 | 50.5 | 85.0 |
| 5 | AR+LJ- r+AR | 4.3 | 2.1 | 51.5 | 85.0 |
| 6 | AR+AK+AR- r | 4.5 | 3.6 | 41.0 | 83.5 |
| 7 | AR+LJ- r+AR-r | 4.6 | 3.3 | 44.5 | 84.5 |

As observed, the properties of the rod coated samples were better than those of the airknife coated samples. It could be seen that the surface of the board is better covered and smoother after a long dwell time rod coater than after an airknife coater. The airknife coated sample was much rougher and the coating mix had penetrated the structure of the board to a greater extent.

Conclusions

The nozzle application technology has become very popular in paper coating. This technology also gives benefits in relatively low speed board grade applications. Pilot trials showed that free jet application is beneficial when making a good coverage. However, a long dwell time is needed for a thick filter cake formation and high coat weights, if an

airknife is to be replaced. Rod metering gives more contour-like coating than blade metering.

5 This study suggests that, in board coating, nozzle application, a long dwell time, and rod metering give excellent coverage and a smooth surface. Board can be coated without
10 airknife technology, by the method investigated, while still achieving a quality comparable or even superior to that of an airknife. Of course, this method can be used for coating paper too.

Thus, while there have been shown and described and pointed out fundamental novel features of the invention as applied
15 to a preferred embodiment thereof, it will be understood that various omissions and substitutions and changes in the form and details of the method and apparatus may be made by those skilled in the art without departing from the the
20 spirit of the invention. For example, it is expressly intended that all combinations of those elements and/or method steps which perform substantially the same results are within the scope of the invention. Substitutions of the elements from one described embodiment to another are also
25 fully intended and contemplated. It is also to be understood that the drawings are not necessarily drawn to scale but they are merely conceptual in nature. It is the intention, therefore, to be limited only as indicated by the scope of the claims appended hereto.

What is claimed is:

1. A method for coating a paper or a paper board web, comprising:

5

- spreading coating mix having a solids content of 55 - 75% on the surface of the web with a nozzle applicator,

10

- levelling and metering the spread coating mix on the surface of the web by a doctor element capable of producing a high hydrodynamic force on the coating layer between the doctor element and the web, the doctor element being located downstream of the applicator so that the dwell time between the spreading of the coating mix to the metering is 72 - 2400 ms.

15

2. A method for coating a paper or a paper board web, comprising:

20

- spreading coating mix having a solids content of 55 - 75% on the surface of the web with a nozzle applicator,

25

- levelling and metering the spread coating mix on the surface of the web by a doctor element capable of producing a high hydrodynamic force on the coating layer between the doctor element and the web, the doctor element being located downstream of the applicator so that the dwell time between the spreading of the coating mix to the metering is 72 - 1212 ms.

30

3. A method according to the claim 1, wherein the web is run at a speed of 100 - 1000 m/s, preferably at a speed of

35

200 - 1000 m/s.

4. A method according to the claim 1 or 2, wherein the doctoring force is at least equivalent to the metering force achieved by a tube pressure of 1.2 bar applied on the back side of a rod bed of a smooth rod having a diameter of 12 mm.
- 5
5. A method according to the claim 4 wherein the doctoring force is at least 1 kN/m.
- 10
6. A method according to the claim 1 or 2, wherein the web is supported by two backing elements, the first backing element supporting the web during spreading of the coating mix and the second supporting the web during doctoring.
- 15
7. A method according to the claim 1 or 2, wherein the web is supported by two backing elements, the first backing element supporting the web during spreading of the coating mix and the second compressible element supporting the web during doctoring.
- 20
8. A method according to the claim 1 or 2, wherein the web is supported by a single compressible backing element.
- 25
9. A method according to the claim 1 or 2, wherein the dwell distance between the spreading of the coating mix and the doctoring is 1400 - 4000 mm.
- 30
10. A method according to the claim 1 or 2, wherein the coating mix is spread on the web by a free jet nozzle applicator, premetering rod nozzle applicator or a premetering blade nozzle applicator.
- 35
11. A method according to the claim 1 or 2, wherein the coating mix is levelled and metered by a smooth or grooved

rod or a small angle blade.

12. A method according to the claim 1 or 2, wherein the amount of applied coating is 30 - 800 g/m², the viscosity of the coating mix is 80 - 140 mPas measured in a capillary viscosimeter at 200 000 - 650 000 1/s shear rate, the metering force is at least 1 kN/m and the metered coat weight is 8 - 25 g/m².

13. An apparatus for coating a paper or a paper board web, comprising:

- a nozzle applicator for spreading coating mix having a solids content of 55 - 75% on the surface of the web,

- a doctor element for levelling and metering the spread coating mix on the surface of the web, the doctor element capable of producing a high hydrodynamic force on the coating layer between the doctor element and the web and being located downstream of the applicator so that the dwell time between the spreading of the coating mix to the metering is 72 - 2400 ms, and

- at least one backing element for supporting the web.

14. An apparatus for coating a paper or a paper board web, comprising:

- a nozzle applicator for spreading coating mix having a solids content of 55 - 75% on the surface of the web,

- 5 - a doctor element for levelling and metering the spread coating mix on the surface of the web, the doctor element capable of producing a high hydrodynamic force on the coating layer between the doctor element and the web and being located downstream of the applicator so that the dwell time between the spreading of the coating mix to the metering is 72 - 1212 ms, and
- 10 - at least one backing element for supporting the web.
- 15 15. An apparatus according to the claim 13 or 14, comprising two backing elements for supporting the web, the first backing element for supporting the web during spreading of the coating mix and the second compressible element for supporting the web during doctoring.
- 20 16. An apparatus according to the claim 13 or 14, comprising a single compressible backing element.
- 25 17. An apparatus according to the claim 13 or 14, wherein the dwell distance between the spreading of the coating mix and the doctoring is 1400 - 4000 mm.
- 30 18. An apparatus according to the claim 13 or 14, wherein the nozzle applicator is a free jet nozzle applicator, premetering rod nozzle applicator or a premetering blade nozzle applicator.
- 35 19. An apparatus according to the claim 13 or 14, wherein the doctor element is a smooth or grooved rod or a small angle blade.
20. An apparatus according to the claim 15, wherein the backing elements are rolls.

21. An apparatus according to the claim 15, wherein at least one of the backing elements, preferably the backing element of the doctor, is a shoe.

1 / 11

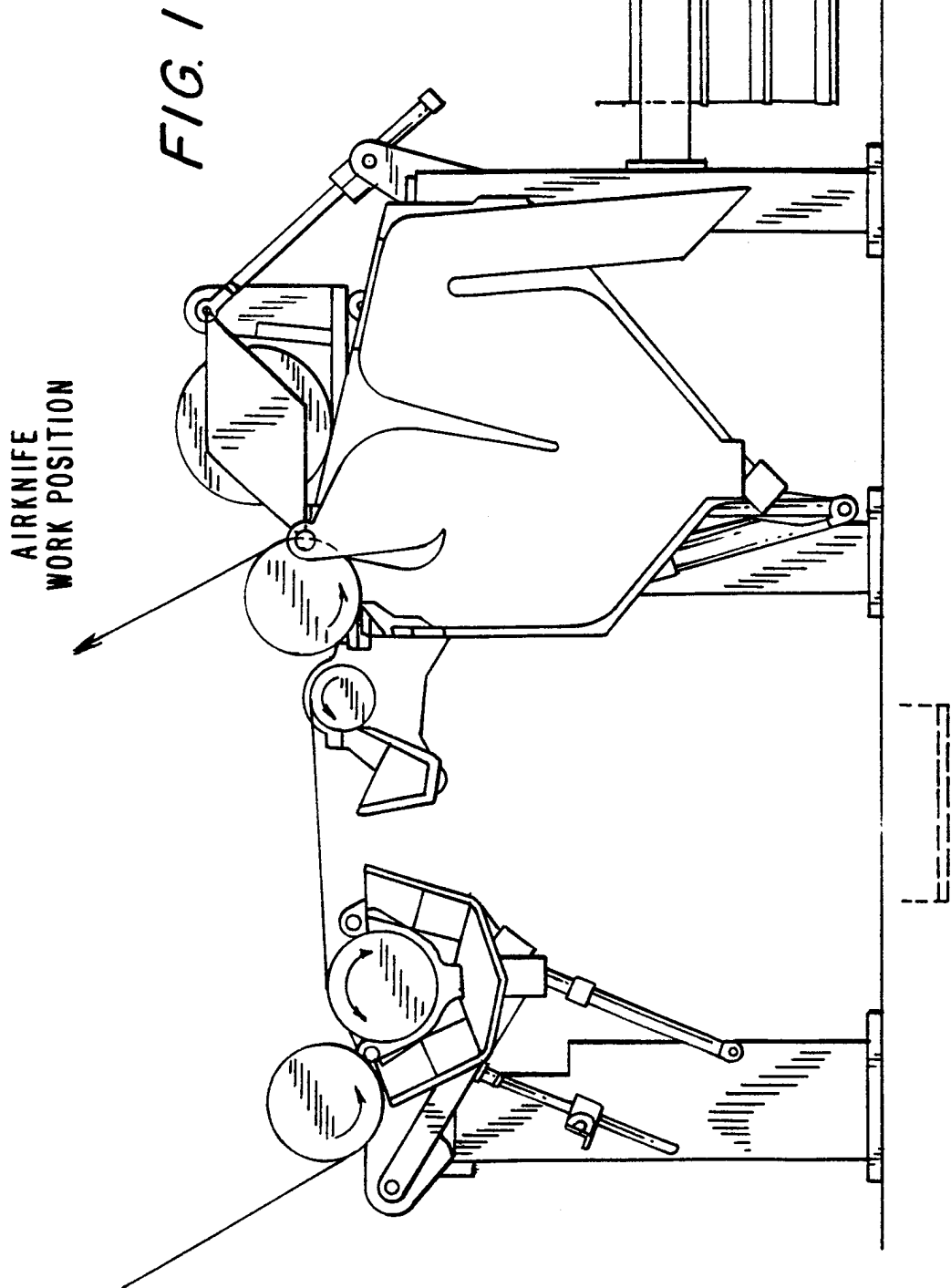

COATING WITH THE SYM-SIZER
C2S CONCEPT

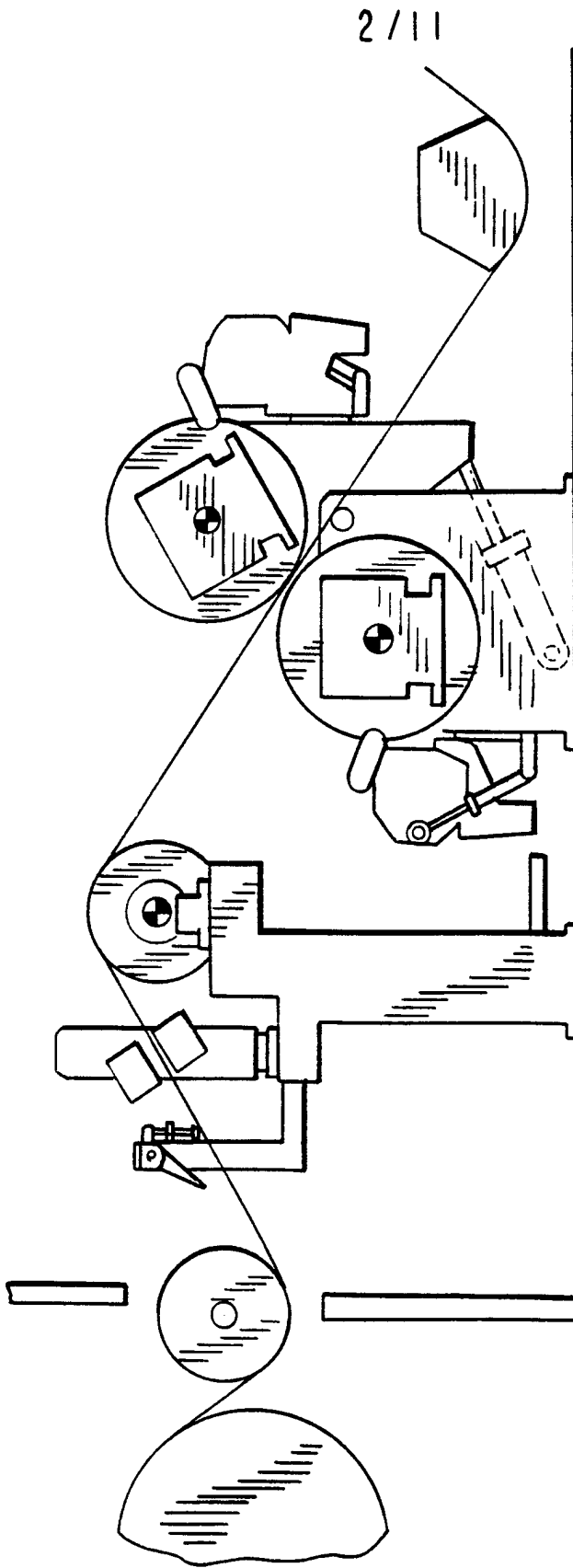

FIG. 2

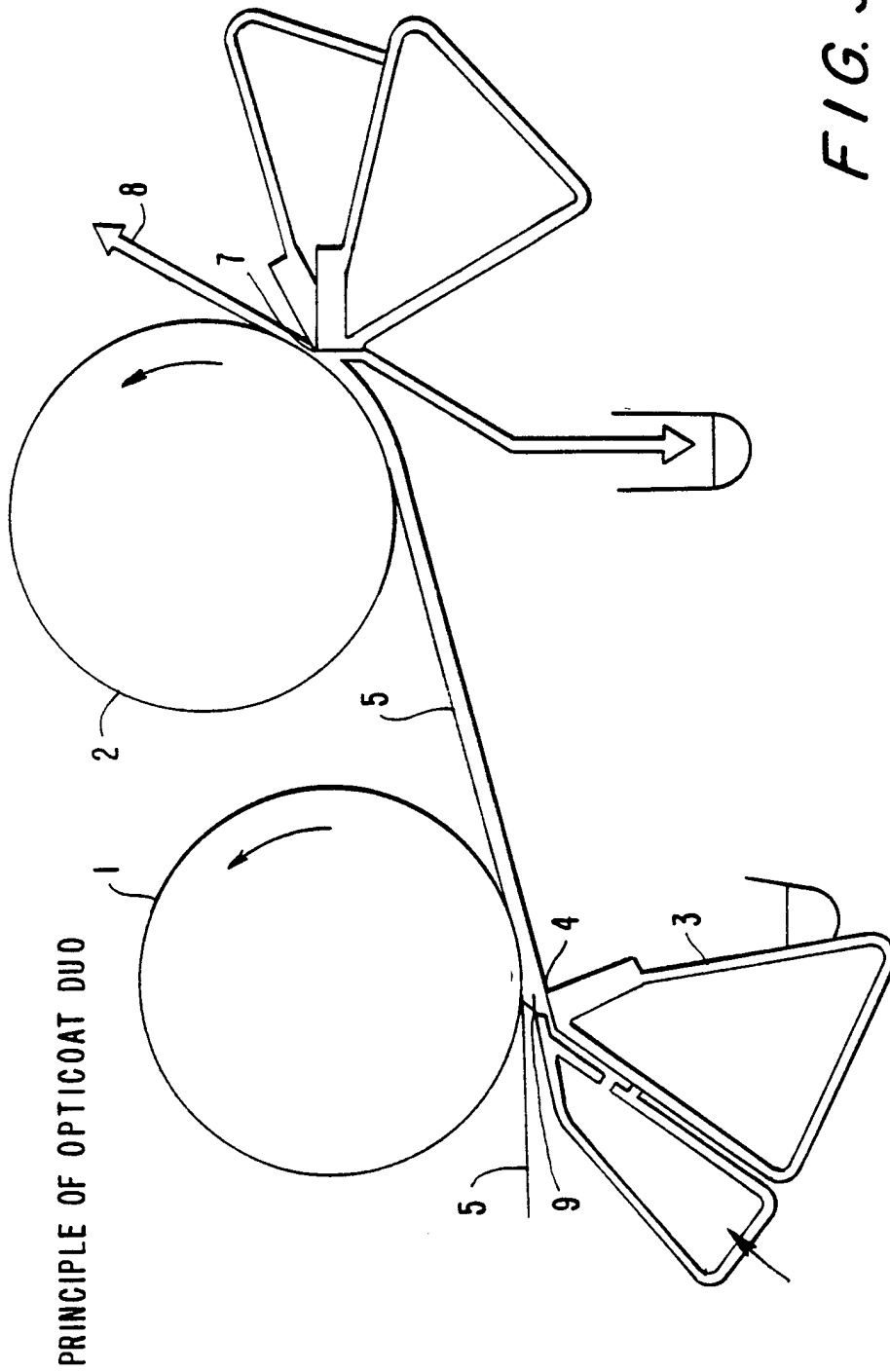
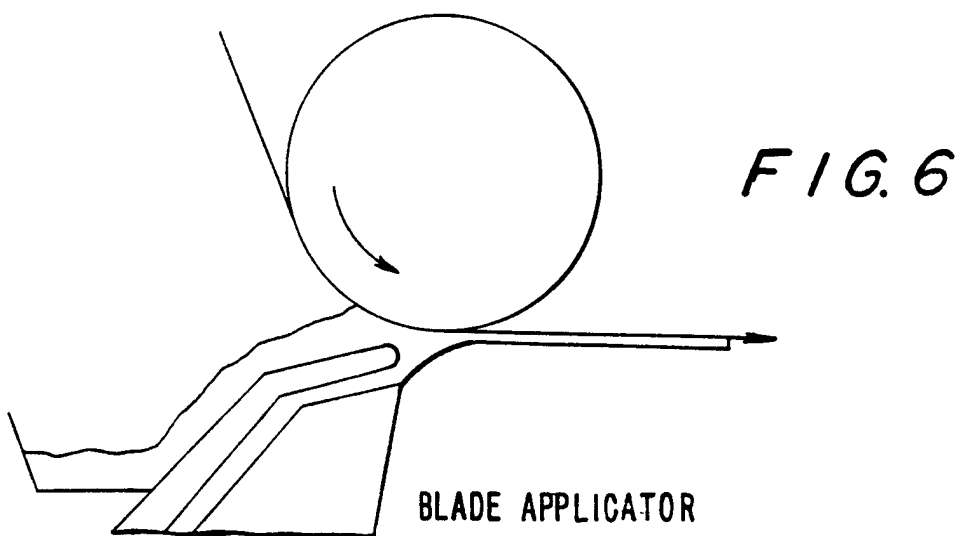
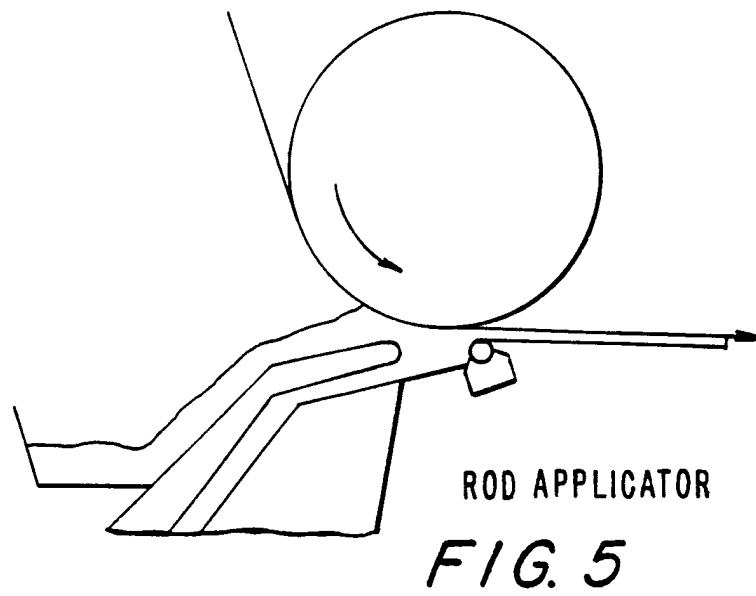
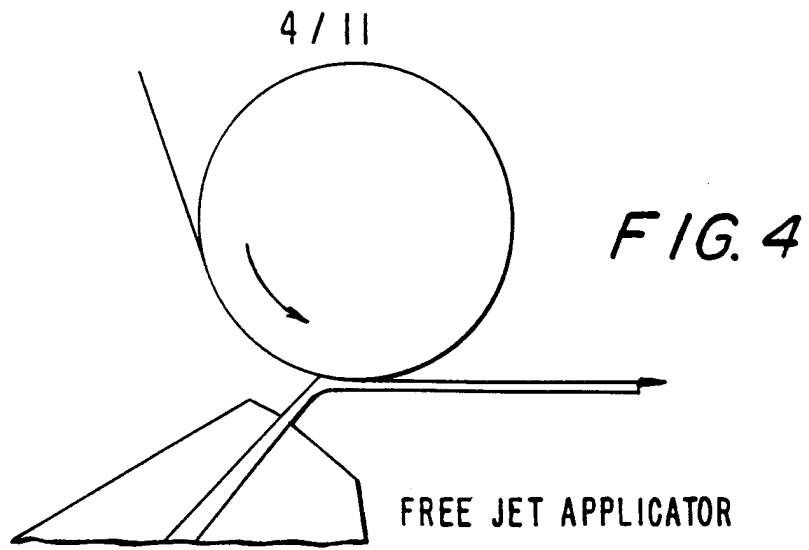

FIG. 3



5 / 11

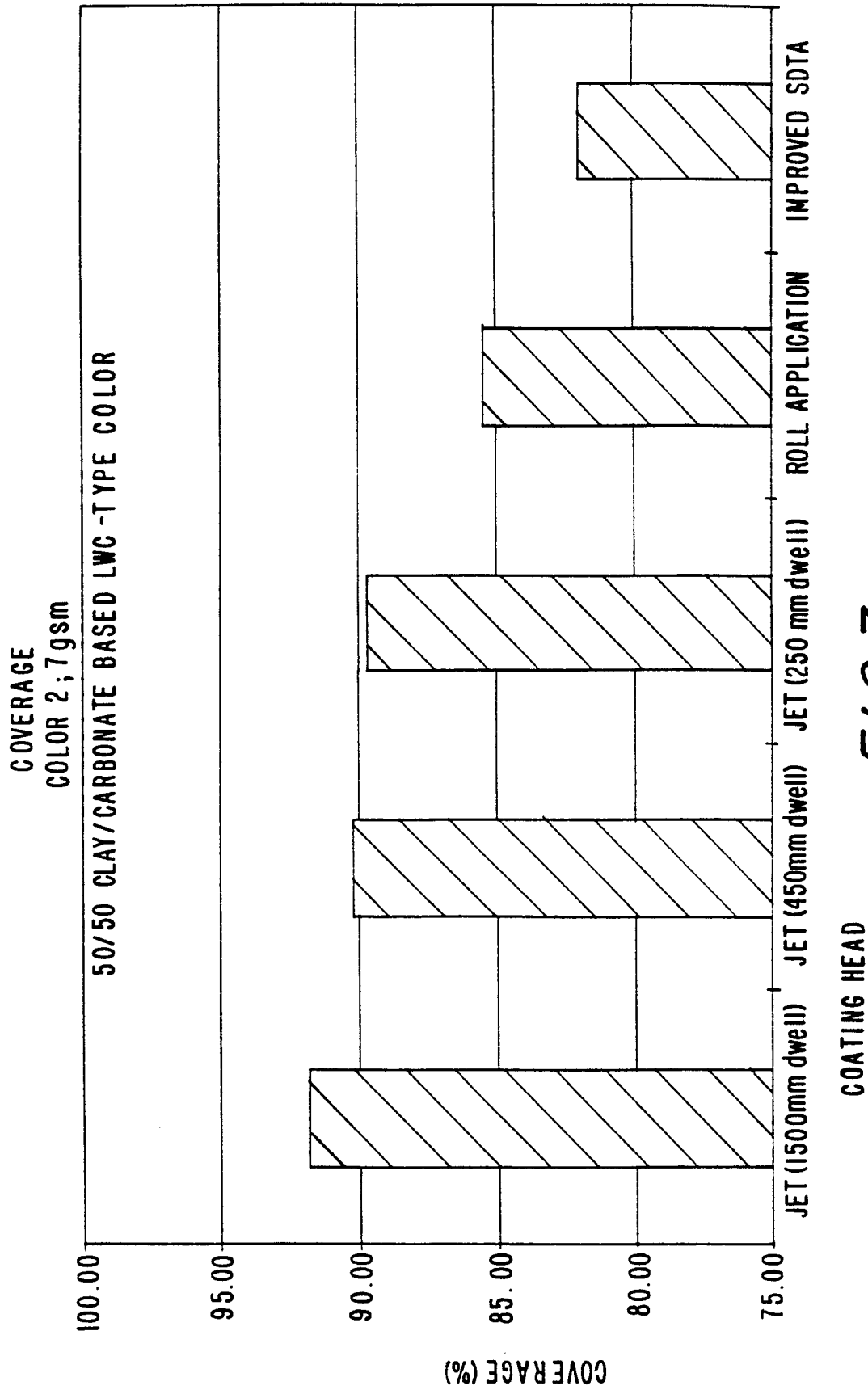

FIG. 7

6 / 11

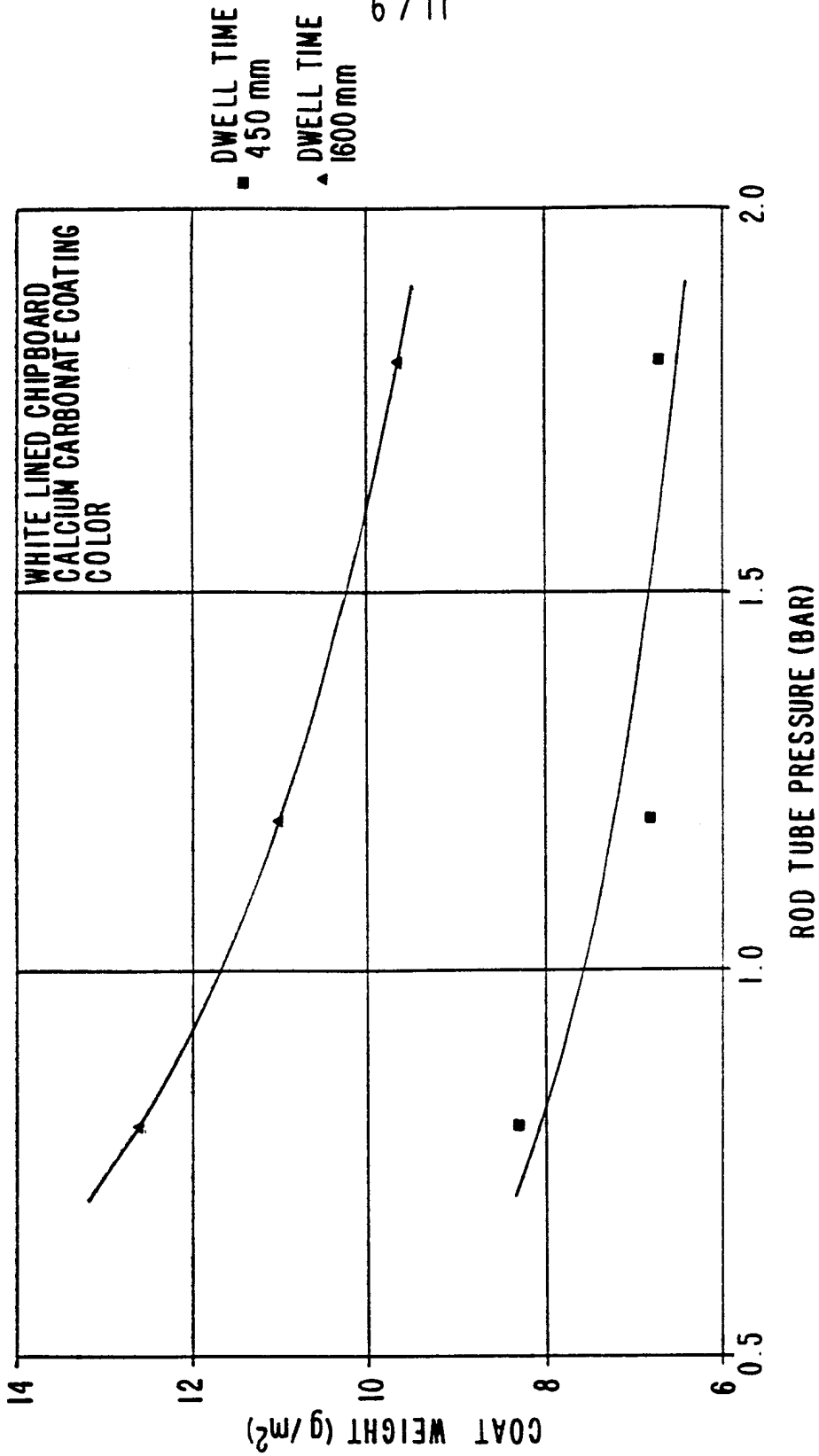

FIG. 8

7 / 11

COATING UNIFORMITY VS ROD PRESSURE
TOP COATING 15 g/m²

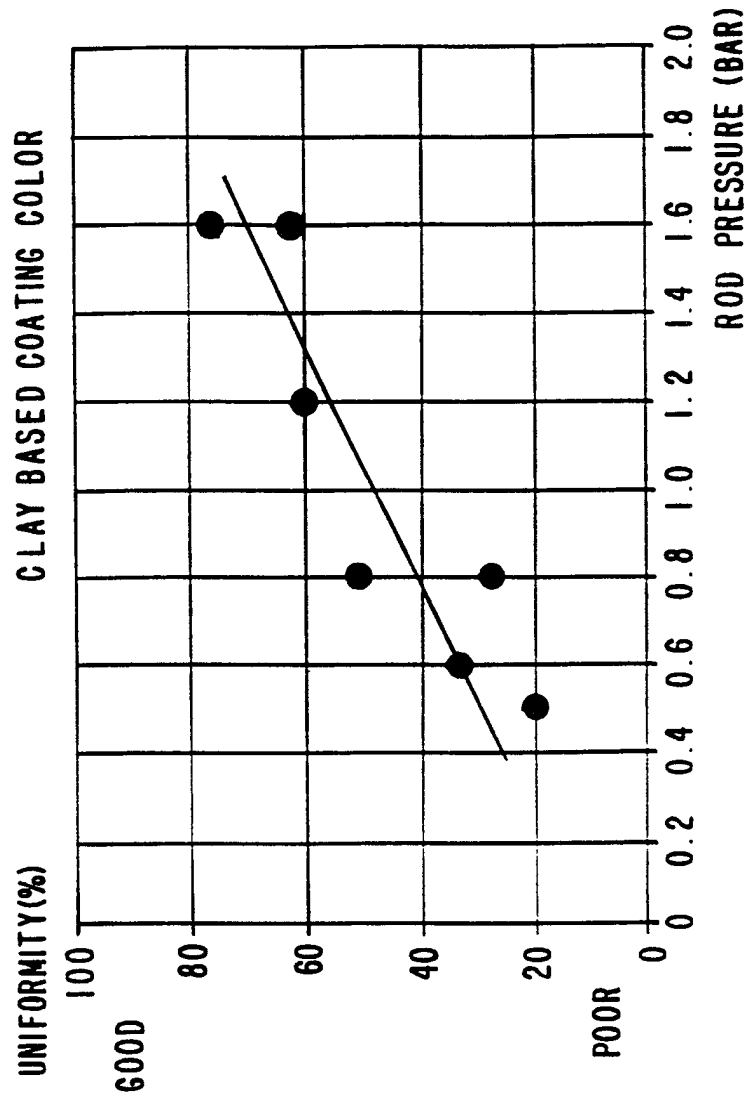

FIG. 9

8 / 11

PPS - s10 BY DIFFERENT MID COATING METHODS

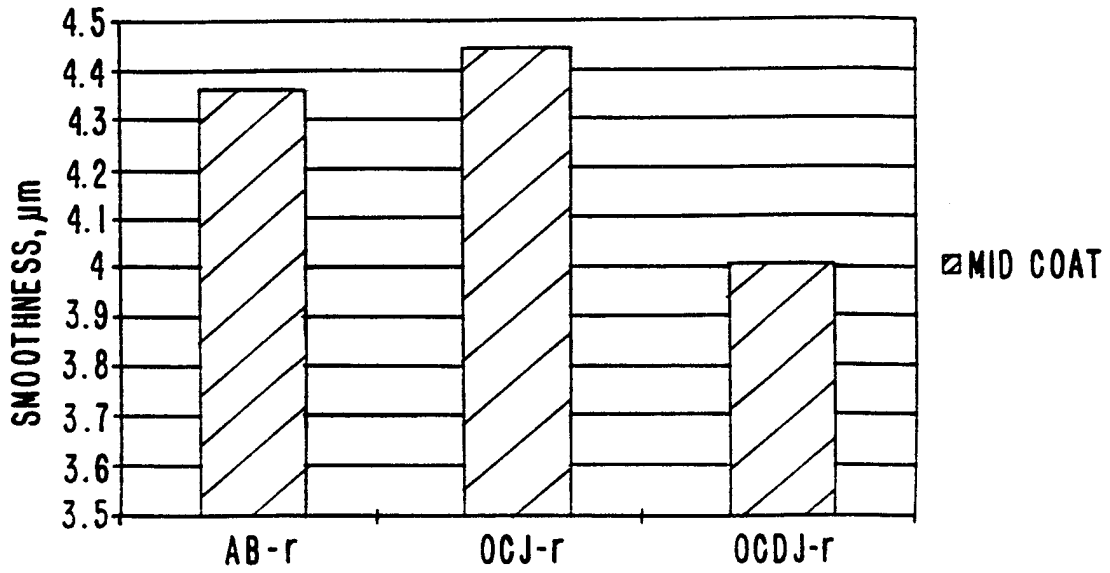

FIG. 10

BENDTSEN BY DIFFERENT MID COATING METHODS

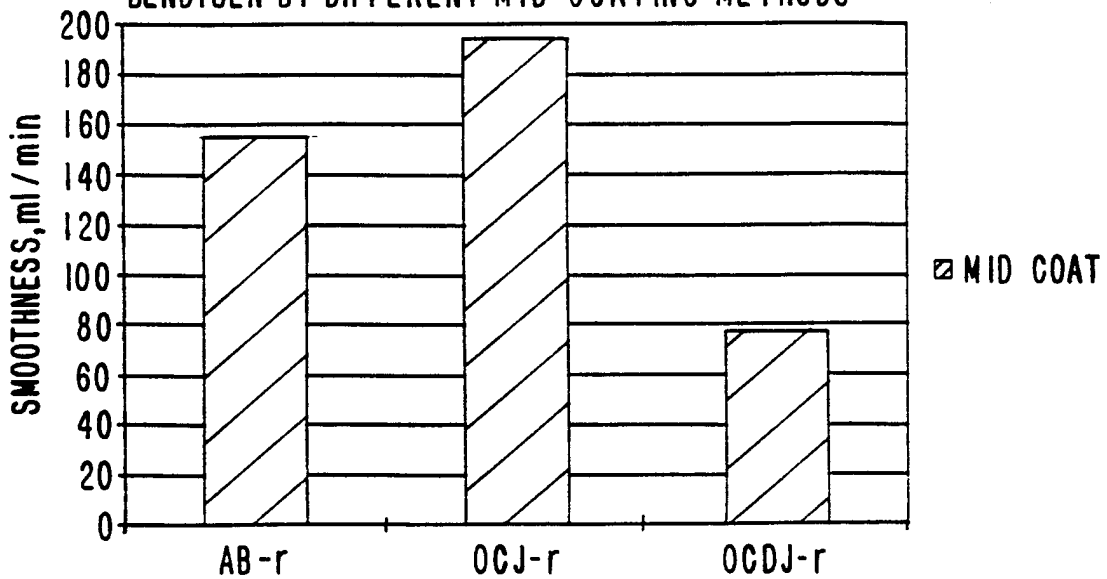

FIG. 11

9/11

DETERMINING OF FORCES AFFECTING THE METERING ELEMENT

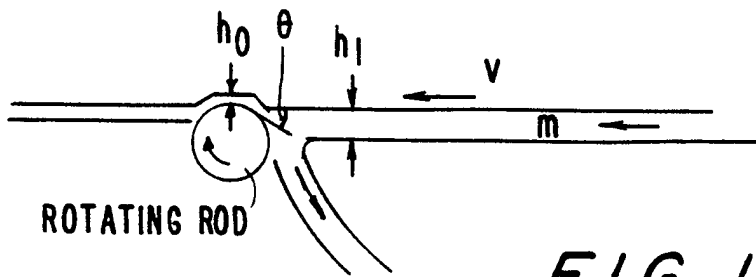

FIG. 12

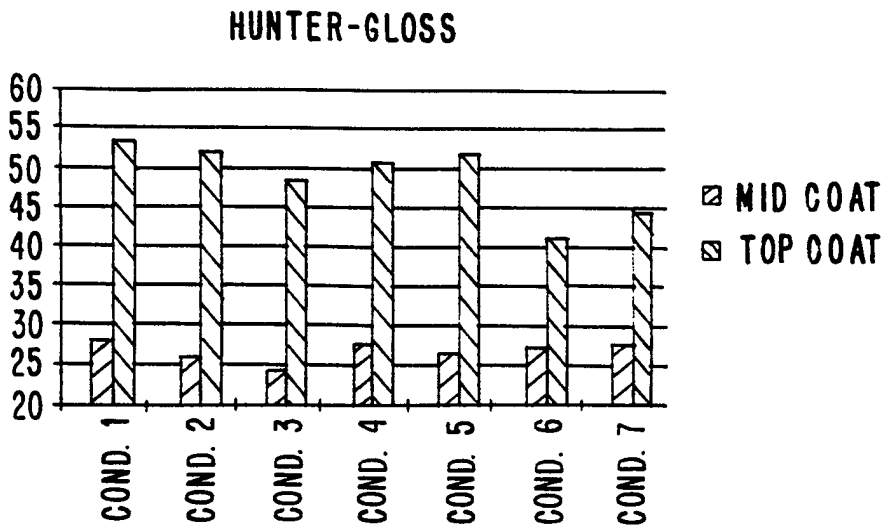

FIG. 17

10/11

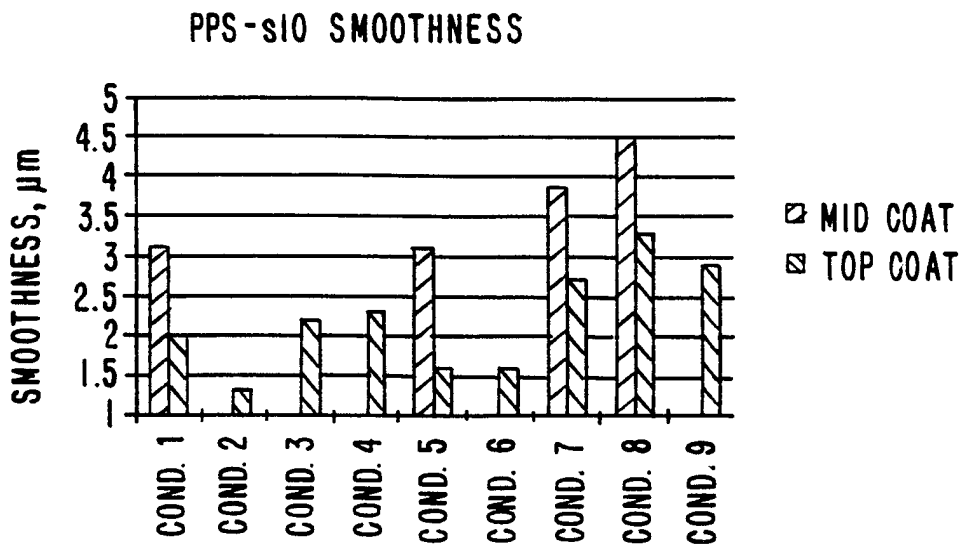

FIG. 13

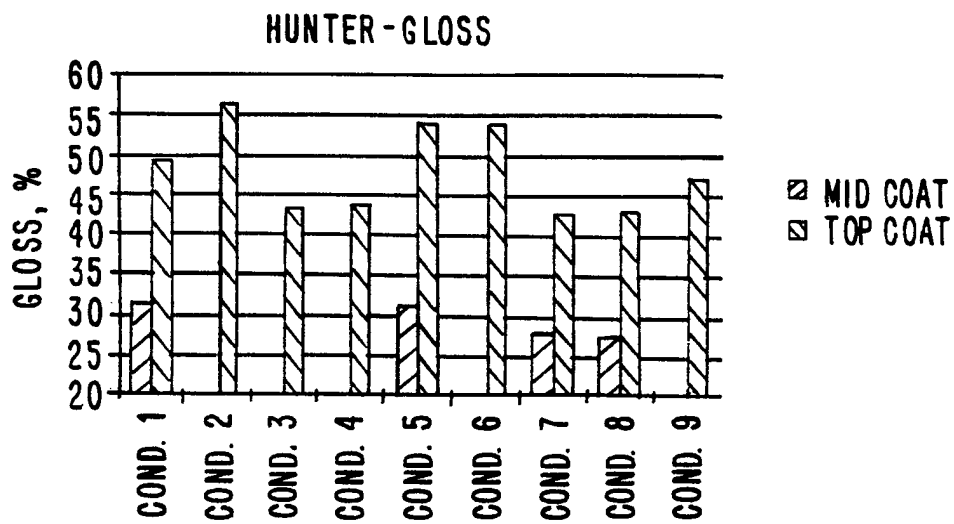

FIG. 14

11 / 11

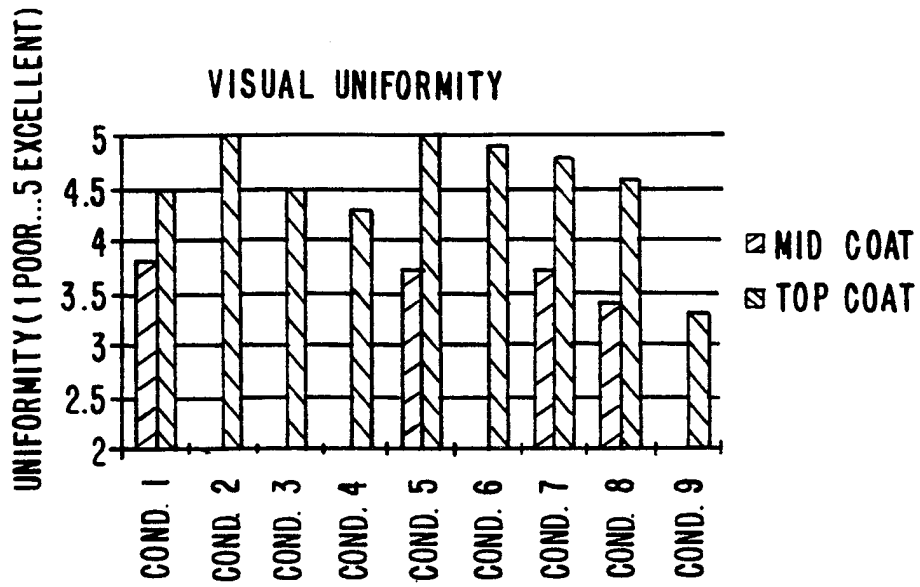

FIG. 15

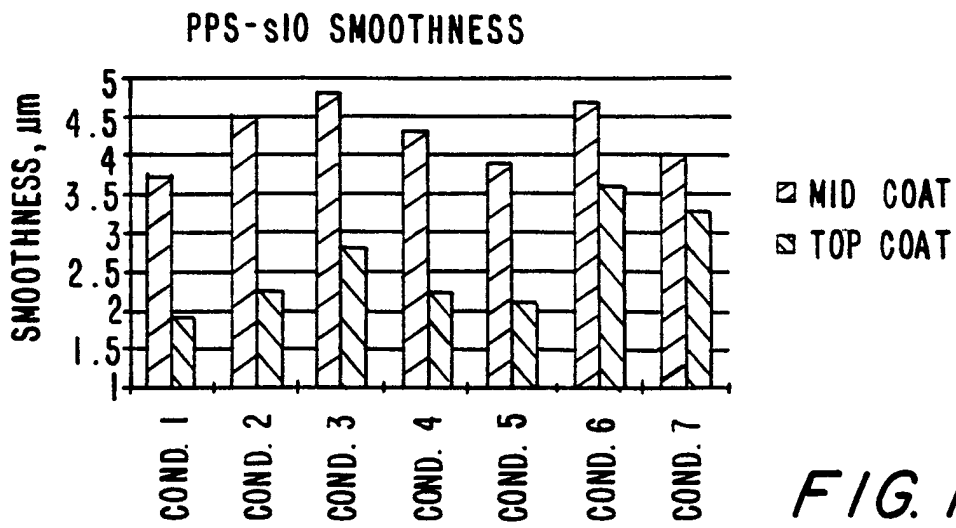

FIG. 16

INTERNATIONAL SEARCH REPORT

International application No.
PCT/US98/09314

| A. CLASSIFICATION OF SUBJECT MATTER | | | | | | | | | | | | | | |
|--|--|---|--|---|--|--|--|--|---|---|--|--|--|--|
| IPC(6) :B05D 3/12; B05C 11/04 US CL :427/356, 361; 118/119, 126, 410, 413, 414 According to International Patent Classification (IPC) or to both national classification and IPC | | | | | | | | | | | | | | |
| B. FIELDS SEARCHED | | | | | | | | | | | | | | |
| Minimum documentation searched (classification system followed by classification symbols) U.S. : 427/356, 361; 118/119, 126, 410, 413, 414 | | | | | | | | | | | | | | |
| Documentation searched other than minimum documentation to the extent that such documents are included in the fields searched | | | | | | | | | | | | | | |
| Electronic data base consulted during the international search (name of data base and, where practicable, search terms used) | | | | | | | | | | | | | | |
| C. DOCUMENTS CONSIDERED TO BE RELEVANT | | | | | | | | | | | | | | |
| Category* | Citation of document, with indication, where appropriate, of the relevant passages | Relevant to claim No. | | | | | | | | | | | | |
| Y | GB 2,272,850 A (VALMET PAPER MACHINERY INC.) 01 June 1994 (01-06-94), see entire document. | 1-21 | | | | | | | | | | | | |
| Y | US 5,112,653 A (DAMRAU et al) 12 May 1992 (12-05-92), see column 14, line 50 through column 16, line 35. | 1-21 | | | | | | | | | | | | |
| A, P | US 5,741,550 A (PALOVIITA et al) 21 April 1998 (21-04-98), see entire document. | 1-21 | | | | | | | | | | | | |
| Y, P | US 5,674,551 A (KOSKINEN et al) 07 October 1997 (07-10-97), see entire document. | 1-21 | | | | | | | | | | | | |
| A | US 5,510,150 A (KOSKINEN) 23 April 1996 (23-04-96), see entire document. | 1-21 | | | | | | | | | | | | |
| A | US 5,104,697 A (HEIKKINEN et al) 14 April 1992 (14-04-92), see entire document. | 1-21 | | | | | | | | | | | | |
| <input checked="" type="checkbox"/> Further documents are listed in the continuation of Box C. <input type="checkbox"/> See patent family annex. | | | | | | | | | | | | | | |
| <table border="0"> <tr> <td>* Special categories of cited documents:</td> <td>*T* later document published after the international filing date or priority date and not in conflict with the application but cited to understand the principle or theory underlying the invention</td> </tr> <tr> <td>*A* document defining the general state of the art which is not considered to be of particular relevance</td> <td>*X* document of particular relevance; the claimed invention cannot be considered novel or cannot be considered to involve an inventive step when the document is taken alone</td> </tr> <tr> <td>*B* earlier document published on or after the international filing date</td> <td>*Y* document of particular relevance; the claimed invention cannot be considered to involve an inventive step when the document is combined with one or more other such documents, such combination being obvious to a person skilled in the art</td> </tr> <tr> <td>*L* document which may throw doubts on priority claim(s) or which is cited to establish the publication date of another citation or other special reason (as specified)</td> <td>*A* document member of the same patent family</td> </tr> <tr> <td>*O* document referring to an oral disclosure, use, exhibition or other means</td> <td></td> </tr> <tr> <td>*P* document published prior to the international filing date but later than the priority date claimed</td> <td></td> </tr> </table> | | | * Special categories of cited documents: | *T* later document published after the international filing date or priority date and not in conflict with the application but cited to understand the principle or theory underlying the invention | *A* document defining the general state of the art which is not considered to be of particular relevance | *X* document of particular relevance; the claimed invention cannot be considered novel or cannot be considered to involve an inventive step when the document is taken alone | *B* earlier document published on or after the international filing date | *Y* document of particular relevance; the claimed invention cannot be considered to involve an inventive step when the document is combined with one or more other such documents, such combination being obvious to a person skilled in the art | *L* document which may throw doubts on priority claim(s) or which is cited to establish the publication date of another citation or other special reason (as specified) | *A* document member of the same patent family | *O* document referring to an oral disclosure, use, exhibition or other means | | *P* document published prior to the international filing date but later than the priority date claimed | |
| * Special categories of cited documents: | *T* later document published after the international filing date or priority date and not in conflict with the application but cited to understand the principle or theory underlying the invention | | | | | | | | | | | | | |
| *A* document defining the general state of the art which is not considered to be of particular relevance | *X* document of particular relevance; the claimed invention cannot be considered novel or cannot be considered to involve an inventive step when the document is taken alone | | | | | | | | | | | | | |
| *B* earlier document published on or after the international filing date | *Y* document of particular relevance; the claimed invention cannot be considered to involve an inventive step when the document is combined with one or more other such documents, such combination being obvious to a person skilled in the art | | | | | | | | | | | | | |
| *L* document which may throw doubts on priority claim(s) or which is cited to establish the publication date of another citation or other special reason (as specified) | *A* document member of the same patent family | | | | | | | | | | | | | |
| *O* document referring to an oral disclosure, use, exhibition or other means | | | | | | | | | | | | | | |
| *P* document published prior to the international filing date but later than the priority date claimed | | | | | | | | | | | | | | |
| Date of the actual completion of the international search 16 JUNE 1998 | | Date of mailing of the international search report 04 AUG 1998 | | | | | | | | | | | | |
| Name and mailing address of the ISA/US Commissioner of Patents and Trademarks Box PCT Washington, D.C. 20231 Facsimile No. (703) 305-3230 | | Authorized officer KATHERINE A. BAREFORD Telephone No. (703) 308-0661 | | | | | | | | | | | | |