

[54] FOLDING CABINET OF MOLDED CONSTRUCTION

[76] Inventor: Kenneth A. MacDonald, 251 York St., Canton, Mass.

[22] Filed: June 28, 1971

[21] Appl. No.: 157,231

[52] U.S. Cl. 312/258, 312/263

[51] Int. Cl. B65d 87/00, B65; , A47b 43/00, A43b 47/04

[58] Field of Search..... 312/205, 257, 258, 312/263

[56] References Cited

UNITED STATES PATENTS

3,485,545	12/1969	Newman et al.....	312/258
3,602,388	8/1971	Hurkamp.....	312/258
3,472,572	10/1969	Himmelreich.....	312/258 X

Primary Examiner—Casmir A. Nunberg
Attorney—Morse, Altman & Oates

[57] ABSTRACT

A foldable base or wall cabinet is fabricated from articulated molded plastic components assembled for quick and easy erection with a minimum number of parts. A front panel formed with integral hinge portions is provided with a pair of articulated side panels also formed with integral hinge portions which cooperate with the front panel portion and are adapted to be folded over against one another when in a collapsed position. A shelf with integral hinge pins pivotally engages the front and side panels by sockets formed between the side panels and the front panel, the shelf being foldable against the front panel when collapsed. Integral locking connections are provided for locking the cabinet in an erected position and various components are interchangeable to reduce the number of molds.

12 Claims, 11 Drawing Figures

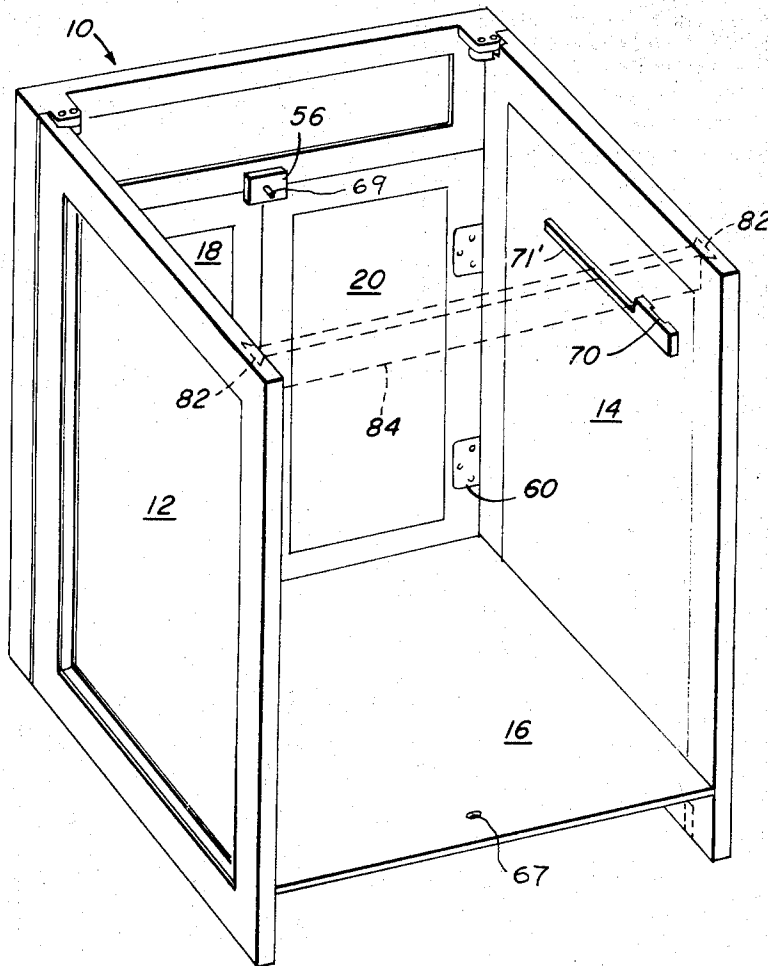

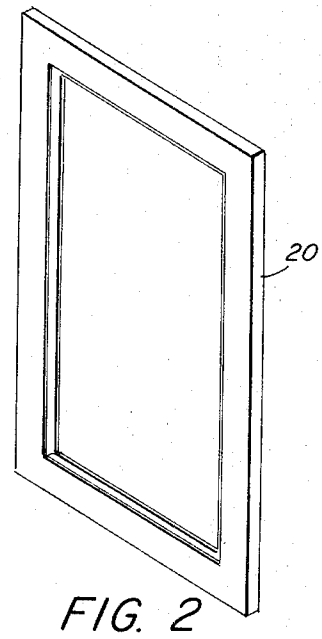
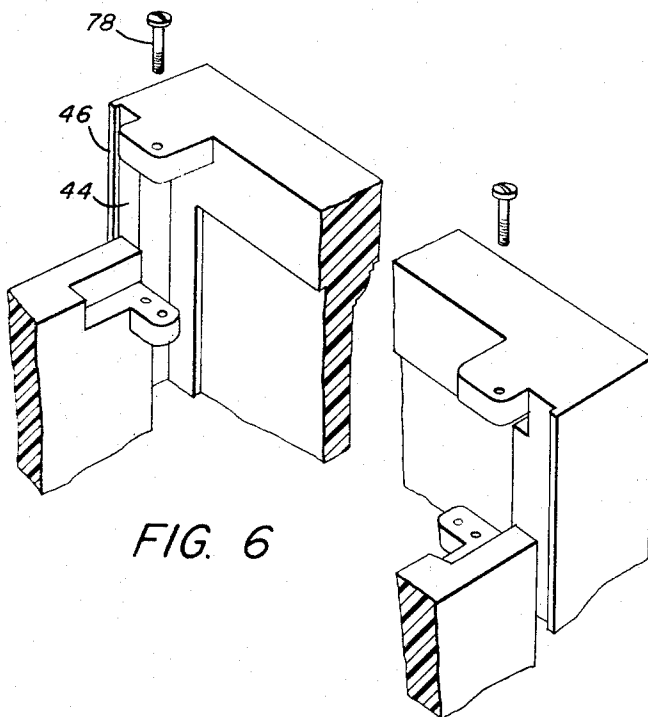
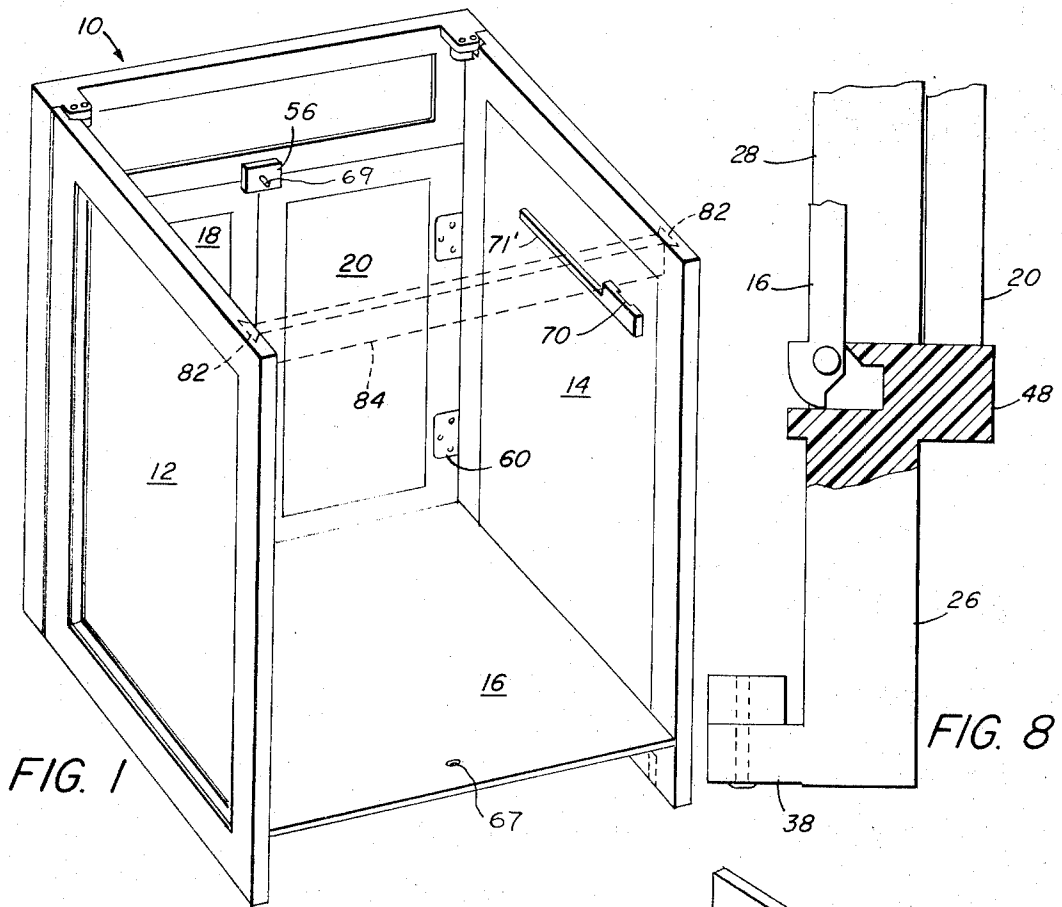

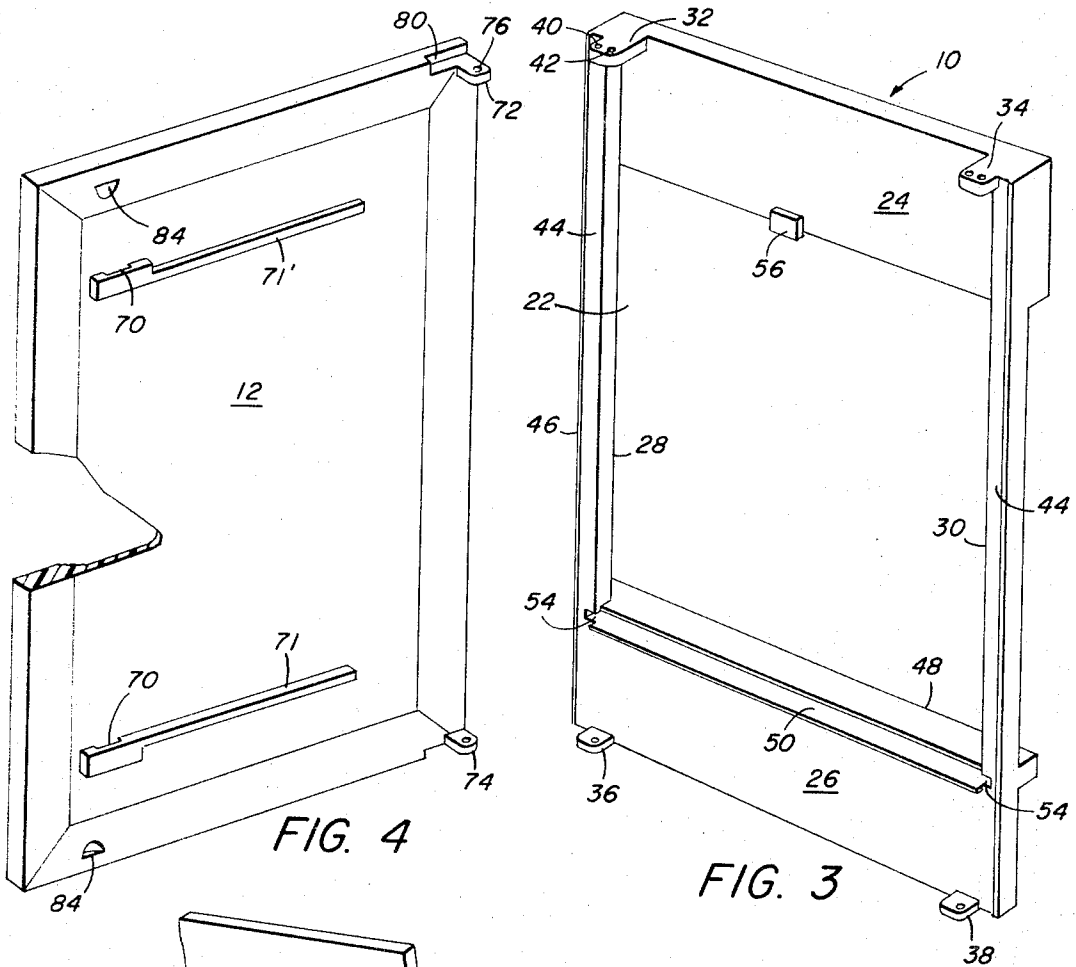

FIG. 4

FIG. 3

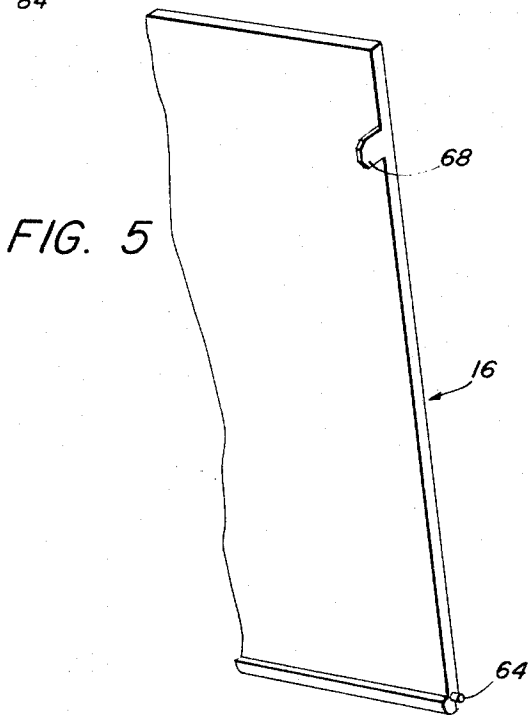

FIG. 5

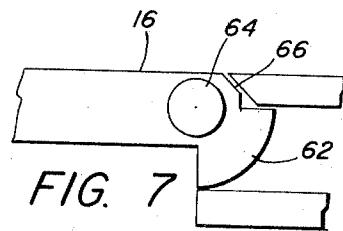
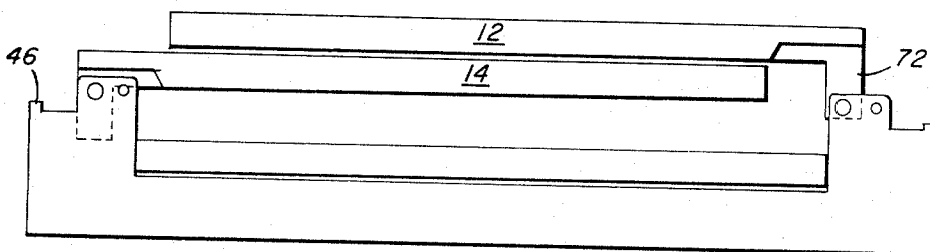
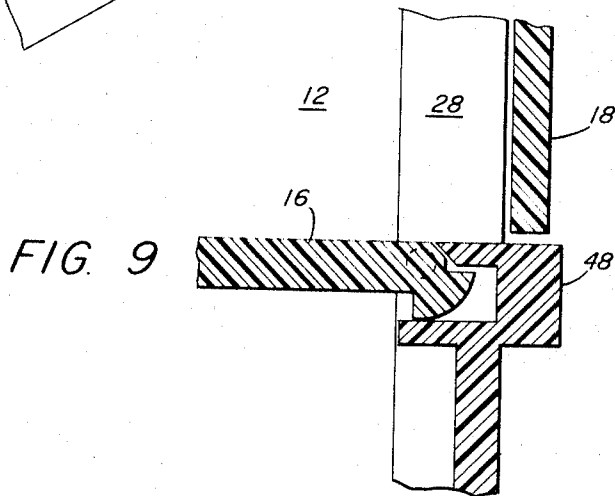
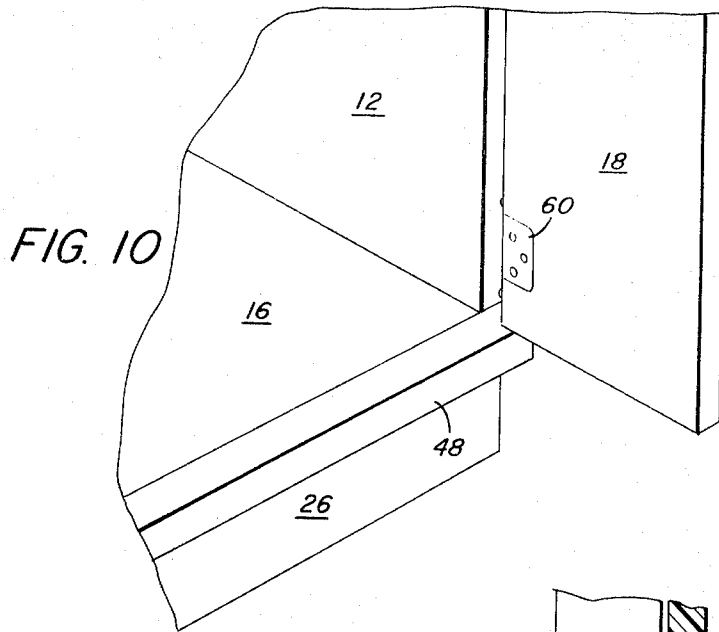

FIG. 7



FOLDING CABINET OF MOLDED CONSTRUCTION

BACKGROUND OF THE INVENTION

1. Field of the Invention

This invention relates generally to folding cabinets and more particularly is directed towards a folding cabinet fabricated from molded plastic components joined in an articulated arrangement.

2. History of the Prior Art

In my co-pending U.S. application Ser. No. 56,535, filed July 20, 1970 entitled "Collapsible Cabinet" and now U.S. Pat. No. 3,644,011 dated Feb. 22, 1972 there is disclosed a cabinet such as used in kitchen work or the like and which is adapted to be folded into a substantially flat condition. Such cabinets reduce the amount of warehouse space required to maintain an inventory of cabinets and also greatly reduce shipping costs by reason of the compact size of the collapsed cabinet. Such cabinets are convenient for carrying by the consumer and readily erected at the site of installation.

The cabinets disclosed in the above-identified application, like most other cabinets of this type, are fabricated for the most part of wood, typically plywood or panelled sheet stock and milled framework. Conventional cabinets, therefore, whether fixed or foldable involve a substantial number of fabricating steps requiring not only a large number of rather expensive machines to carry out the cutting, shaping, milling and other manufacturing steps, but also involve many assembly operations. Furthermore, many cabinets of this type are laminated on their exposed surfaces or at least over a part thereof with a hardened plastic stratum such as that sold under the trademark FORMICA. Such facings, while enhancing the appearance and durability of the cabinet, also introduce additional fabrication steps and associated machinery to perform the lamination.

It is an object of the present invention to provide a cabinet that may be molded substantially entirely from plastic so as to greatly reduce the number of fabricating steps and personnel required to produce cabinets on a mass production basis with a minimum number of parts. A further object of this invention is to provide a collapsible cabinet of molded plastic components wherein different parts are interchangeable to reduce the number of molds required to produce a line of cabinets of different sizes.

SUMMARY OF THE INVENTION

This invention features a collapsible cabinet of predominately molded plastic components, comprising a front panel formed with at least one opening there-through, at least one door hinged to said front panel for closing said opening, a pair of rearwardly extending side panels hinged to the front panel and adapted to fold in against the front panel in overlapping offset relation, said front panel being formed with a transverse groove in the rear face thereof extending between side panels and forming opposing sockets therewith, a shelf panel mounted in said groove and formed with outwardly extending pins received in said sockets for hinging said shelf panel thereto, said shelf panel being foldable against said front panel, means supporting said shelf apart from said pins in a folded or erected position and integral cooperating locking members formed on

said shelf panel and said side panels for locking said shelf and side panels when in an erected condition.

BRIEF DESCRIPTION OF THE DRAWINGS

- 5 FIG. 1 is a perspective rear view of an erected foldable cabinet made according to the invention,
 FIG. 2 is a view in perspective of a door panel for the cabinet of FIG. 1,
 FIG. 3 is a view in rear perspective of the front panel portion of the cabinet,
 FIG. 4 is a view in perspective of one of the side panels,
 FIG. 5 is a fragmentary view in perspective of the cabinet shelf,
 FIG. 6 is an exploded fragmentary perspective view showing the front panel and side panel assembly,
 FIG. 7 is a detailed side elevation of the hinged portion of the shelf panel,
 FIG. 8 is a fragmentary sectional view in side elevation showing the shelf panel in a folded position with respect to the front panel,
 FIG. 9 is a view similar to FIG. 8 but showing the shelf panel in an open position,
 FIG. 10 is a fragmentary front perspective view showing details of the cabinet assembly, and,
 FIG. 11 is a top plan view showing a cabinet in a folded condition.

DETAILED DESCRIPTION OF THE PREFERRED EMBODIMENTS

Referring now to FIG. 1 of the drawings, the cabinet is comprised of articulated panel members adapted to fold in against one another for storage and shipping and to be swung out into an open position for erection and installation. The cabinet is generally organized about a front panel member 10 having a pair of rearwardly extending side panel members 12 and 14 hinged at either side of the front panel member and a rearwardly extending shelf panel 16 hinged horizontally across the lower rear portion of the front panel. The front panel of the illustrated embodiment is provided with a pair of door panels 18 and 20 hinged to the sides thereof across an opening 22 formed in the front panel member.

In the preferred form of this invention, the various panels are fabricated from plastic, preferably a structural foam plastic, using molding techniques such as injection molding. Structural foamed polystyrene, for example, may be employed since such material is strong, hard and presents a wood-like appearance in a finished state. Such material can be provided in a variety of colors or may be stained or otherwise finished.

The front panel 10, as best shown in FIG. 3, is of one-piece molded construction comprised of an upper cross panel 24 and a lower cross panel 26 connected by vertical supports 28 and 30 defining the opening 22. Formed adjacent each corner at the top and bottom edges of the front section 10 are integral hinge members 32, 34, 36 and 38 projecting rearwardly from the rear face of the panel 10 and formed with a pair of holes 40 and 42. The hinge members are located in-board of the vertical supports 28 and 30 each of which is formed with a flat rear face 44 along the outer edge of which is formed an elongated lip 46. The flat face and lip cooperate with the side panel members 12 and 14 not only to serve as a stop for the side panel members but also to hide the joint between the side panel

members and the front panel member when the cabinet is erected.

The lower cross panel 26 is formed at its top portion with a forwardly extending ledge portion 48 in the rear face of which is formed transverse groove 50 terminating at each outer end in oppositely facing sockets 52 and 54, which also open to the rear face 44 of the vertical supports 28 and 30 for reasons that will presently appear. The function of the groove and the sockets is to pivotally support and engage the shelf panel 16 as will be described more fully below.

In the rear face of the upper cross panel 24 is formed an abutment 56 which extends below the edge to serve as a doorstop for the two doors 18 and 20 hinged to the vertical supports 28 and 30. Each of the doors 18 and 20, as shown in FIG. 2, is of a simple rectangular molded construction. The doors 18 and 20 are hinged to the supports 28 and 30 by conventional metal hinges 60 or pin type hinges may be employed with pins, one of which is spring-loaded and the other fixed at the top and bottom edges of the door and cooperating sockets formed in the front panel on opposite sides of the door opening.

The shelf panel 16, best shown in FIG. 5, is of one-piece construction, rectangular in outline and formed on its lower leading edge, where it joins the front panel section 10, with an offset arcuate rib 62, the curved outer face of which is generally concentric with the axis of a pair of coaxial lugs or posts 64 extending from both side edges of the shelf panel adjacent the leading end thereof. The forward end of the shelf panel 16 is formed with a right angular notch 66 extending across the full width thereof and is of a depth substantially corresponding to the thickness of the upper wall forming the transverse groove 50 whereby when the shelf panel is lying in a horizontal flat position, as shown in FIGS. 1, 9 and 10, the upper surface of the shelf will be flush with the upper surface of the ledge portion 48. The notch 66 serves to position one end of the shelf with respect to the front panel member and to cooperate with the groove 50 to permit a hinging action therewith.

The rib 62 supports the front edge of the shelf whether the shelf is in the horizontal or vertical position to prevent strain being placed on the posts 64. Thus, if the cabinet should be dropped during shipment, the posts will not break. The rib also cooperates with the groove 50 to straighten any warpage that may develop in the shelf.

The shelf may also be formed with a hole 67 near the rear thereof to receive a pin 69 formed in the abutment 56 when the shelf is folded. This removes strain from the posts 64 if the cabinet is stored or shipped upside down. Alternatively, a shoulder could be formed in the rear face of the front panel to engage the rear edge of the shelf when folded.

The posts 64 are received in the sockets 54 at each end of the groove 50 and are locked in position by means of the leading edges of the side panels 12 and 14 when the side panels are folded into the open position. The side panels serve to cooperate with the front panel to form a simple yet highly efficient hinge socket for the shelf panel posts 64. When initially assembling the components, the shelf is simply placed in against the front panel member with the post 64 placed in their respective sockets. When the side panel members are subsequently connected to their hinges, the shelf panel

is prevented from dropping out of position. In the rear portion of the shelf 16 at each side edge thereof, is a downwardly extending ear 68 which serves to lock with a cooperating slot 70 formed in an integral rib shoulder 71 molded in the inner face of the side panels to the shelf. Two such shoulders 71 are provided, one upper and lower so that the side panels are interchangeable and only one mold is required.

Referring now particularly to the side panels 12 and 14, each is of molded plastic construction and rectangular in outline. Each of the side panels is hinged to the front panel 10 by means of integral hinge portions 72 and 74 extending from the inner face thereof adjacent a forward edge and at the upper and lower corners thereof. Each of the hinged portions is formed with a hole 76 adapted to register with one of the holes 40 or 42 in the hinge members of the front panel and receive a hinge pin or screw 78 inserted therethrough. Above and below each of the hinge portions 72 and 74 is a recessed cutout 80 to accommodate the projecting hinge portions of the front panel member when the side panels are folded in a closed position, as best shown in FIG. 11.

The double hole arrangement for the front panel hinge members permits the two side panels to be hinged in an offset fashion so that they may overlap one another in parallel relation when folded as shown in FIG. 11. Thus, the panel 14 is hinged to the outer set of holes 40 while the panel 12 is hinged to the inner-most holes 42. If the panels were hinged in the same way on each side, it would not be possible to fold the sides in an overlapping parallel fashion. It will be noted that the holes 76 for the hinge members 72 and 74 are located near the outer ends of the hinge members as compared with the holes in the hinge members for the other panel 14 wherein the holes are located closer to the panel surface. This permits the panel 12 to overlap the panel 14 and, by virtue of the hinging to the hole 42, can swing out against the vertical supports with both side panels bearing against the respective flat faces 44 in the same relative position.

On the inner face of each side panel, there are formed the two integral horizontal shoulders 71 and 71', the lower of which is even with the upper part of the slot 70 to support the shelf panel 16 in its normal position. Each of the side panels may also be formed with one or more indents 84. The indent is formed on the inner face of the panel along the upper margin and serves as a starting hole for screws to fasten a counter-top or the like permanently to the erected cabinet.

In the top and bottom edges of the side panels near the rear edges thereof, are formed dovetailed grooves 82 to receive the matching ends of a cross-brace 84. The brace serves to stabilize the cabinet and provides a means for screwing the cabinet to a wall for permanent installation.

While normally a rear panel to close the back of the cabinet is not required for most installations, such panels may be added as separate items and locked to the side panels when erected. The back panel may be of a simple rectangular outline and formed with integral pad eyes at each corner thereof on the inner face of the panel. The pad eyes may register with similar cooperating pad eyes formed integral on the rear inner margins of the side panels and locking pins may be inserted into the registered pad eyes to lock the rear panel in position.

Certain of the panels are interchangeable to reduce the number of molds required to fabricate a line of cabinets. For example, the side panels may be used with front panels of various widths and designs and the door panels 18 and 20 may be used interchangeably as may the side panels.

Since the parts may be injection-molded they may be produced much more quickly and at a much lower cost per unit. The resulting cabinet not only is of a rugged, quality construction, but is quite similar in appearance to conventional wood cabinets. The panels may be molded with a slight wood grain surface by properly graining the mold cavities. Obviously, a variety of relief designs may be used to produce different cabinet styles. The assembly of the cabinet is a simple matter which may be carried out quickly and folded for packaging in a relatively shallow flat carton for storage and shipment. Such a carton is particularly easy to handle or transfer in a car by a retail consumer. The size of the collapsed cabinet greatly reduces the amount of warehouse space required to maintain an inventory of the cabinets and also greatly reduces shipping costs. Once at the site, the cabinets are easily erected without the need of special tools.

Having thus described the invention what I claim and desire to obtain by Letters Patent of the United States is:

1. A foldable cabinet, comprising
 - a. a front panel formed with an opening there-through,
 - b. rearwardly extending fixed hinge members formed integral with said front panel adjacent each side thereof,
 - c. said front panel being formed with a rearwardly facing transverse groove in the back side thereof below said opening,
 - d. a door hinged to said front panel across said opening,
 - e. a side panel hinged along each side of said front panel and formed with inwardly extending fixed integral hinge members opposite said front panel hinge members and a pin engaging each cooperating pair of front and side panel hinge members for pivotal engagement,
 - f. said side panels being formed with integral oppositely facing shoulders substantially co-planar with said groove,
 - g. a shelf panel dimensioned to fit between said side panels when opened and having its leading edge mounted in said groove,
 - h. said shelf being formed with integral pivot pins extending from opposite side edges adjacent said leading edge and retained in said groove by means of the adjacent leading edges of said side panels.
2. A foldable cabinet according to claim 1 wherein at least some of said panels are of molded plastic construction.
3. A foldable cabinet according to claim 1 wherein the hinge members of one side panel are longer than the hinge members of the other side panel.
4. A foldable cabinet according to claim 1 including cooperating lock means formed integrally on said shelf

panel and said side panels.

5. A foldable cabinet according to claim 1 including an integral abutment formed in said front panel for stopping said door.

6. A foldable cabinet according to claim 1 wherein one of said side panels is hinged further from the side edge of said front panel than the other of said side panels whereby said side panels may be folded against said front panel in overlapping parallel relation.

7. A foldable cabinet according to claim 1 wherein said front panel is formed with a lip along the outer rear vertical edges thereof at the juncture of the hinged side panels.

8. A foldable cabinet according to claim 1 including cooperating restraint means located at outer margin of said shelf panel opposite said leading edge and at the rear face of said front panel above said opening for restraining said shelf-member against displacement when folded.

9. A foldable cabinet according to claim 8 wherein said restraint means includes a post extending from the rear face of said front panel and said shelf panel is formed with a post-receiving socket adjacent the outer edge thereof.

10. A foldable cabinet according to claim 1 wherein said side panels are interchangeable.

11. A foldable cabinet according to claim 1 wherein said rearwardly extending hinge members are each formed with at least two pin-receiving vertical holes spaced apart along a plane parallel to the plane of said front panel.

12. A foldable cabinet, comprising

- a. a front panel formed with an opening there-through,
- b. fixed hinge members formed integral with said front panel adjacent each side thereof,
- c. said front panel being formed with a rearwardly facing transverse groove in the backside thereof below said opening,
- d. a door hinged to said front panel across said opening,
- e. a side panel hinged along each side of the front panel and formed with integral hinge members opposite said front panel hinge members and connected thereto,
- f. said side panels being formed with integral oppositely facing shoulders substantially co-planar with said groove,
- g. a shelf panel dimensioned to fit between said side panels when opened and having its leading edge mounted in said groove,
- h. said shelf being formed with integral pivot pins extending from opposite side edges adjacent said leading edge and retained in said groove by means of the edges of said side panels,
- i. the leading edge of said shelf panel being formed with an arcuate offset rib to permit said shelf panel to be pivoted in said groove and provide an upper surface flush with the lower edge of said opening when said shelf panel is in an open position.

* * * * *