



(12) **United States Design Patent**  
**Skidmore et al.**

(10) **Patent No.:** **US D626,073 S**  
(45) **Date of Patent:** **\*\* Oct. 26, 2010**

(54) **PANEL MOUNTED MULTI-POLE POWER CONNECTOR WITH CENTRAL ATTACHMENT**

(75) Inventors: **Allyssa M Skidmore**, Fitchburg, MA (US); **Brian F Davies**, Acton, MA (US); **Craig H Baker**, Shrewsbury, MA (US)

(73) Assignee: **Anderson Power Products, Inc.**, Sterling, MA (US)

(\*\*) Term: **14 Years**

(21) Appl. No.: **29/363,194**

(22) Filed: **Jun. 7, 2010**

(51) **LOC (9) Cl.** ..... **13-03**

(52) **U.S. Cl.** ..... **D13/146**

(58) **Field of Classification Search** ..... D13/133, D13/146-147, 153, 154, 156, 184; 439/282, 439/292, 345, 346, 352, 374, 483, 594, 598  
See application file for complete search history.

(56) **References Cited**

U.S. PATENT DOCUMENTS

4,449,776 A \* 5/1984 Carmo et al. .... 439/350

(Continued)

*Primary Examiner*—Daniel D Bui

(74) *Attorney, Agent, or Firm*—Vern Maine & Associates

(57) **CLAIM**

The ornamental design for a panel mounted multi-pole power connector with central attachment, as shown and described.

**DESCRIPTION**

FIG. 1 is a front view of a panel mounted multi-pole power connector with central attachment showing our new design;

FIG. 2 is a back view thereof;

FIG. 3 is a top view of the first embodiment of a panel mounted multi-pole power connector with central attachment showing our new design;

FIG. 4 is a bottom view thereof;

FIG. 5 is a right side view thereof;

FIG. 6 is a left side view thereof;

FIG. 7 is a front top perspective view thereof;

FIG. 8 is a front bottom perspective view thereof;

FIG. 9 is a back bottom perspective view thereof;

FIG. 10 is a top view of the second embodiment of a panel mounted multi-pole power connector with central attachment showing our new design;

FIG. 11 is a bottom view thereof;

FIG. 12 is a right side view thereof;

FIG. 13 is a left side view thereof;

FIG. 14 is a front top perspective view thereof;

FIG. 15 is a front bottom perspective view thereof;

FIG. 16 is a back bottom perspective view thereof;

FIG. 17 is a top view of the third embodiment of a panel mounted multi-pole power connector with central attachment showing our new design;

FIG. 18 is a bottom view thereof;

FIG. 19 is a right side view thereof;

FIG. 20 is a left side view thereof;

FIG. 21 is a front top perspective view thereof;

FIG. 22 is a front bottom perspective view thereof;

FIG. 23 is a back bottom perspective view thereof;

FIG. 24 is a top view of the fourth embodiment of a panel mounted multi-pole power connector with central attachment showing our new design;

FIG. 25 is a bottom view thereof;

FIG. 26 is a right side view thereof;

FIG. 27 is a left side view thereof;

FIG. 28 is a front top perspective view thereof;

FIG. 29 is a front bottom perspective view thereof; and,

FIG. 30 is a back bottom perspective view thereof.

The broken line portion of the figure drawings is included to show unclaimed subject matter only and forms no part of the claimed design.

**1 Claim, 30 Drawing Sheets**

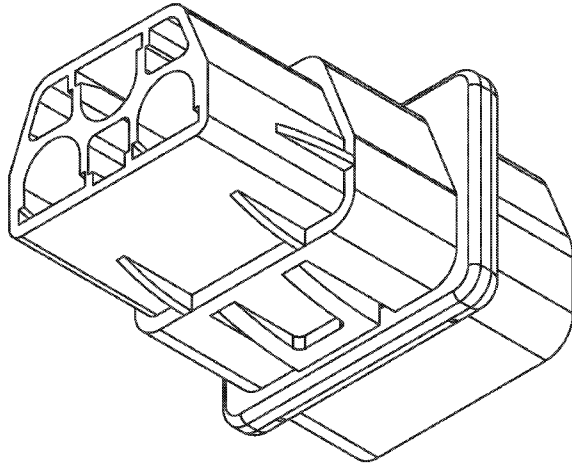
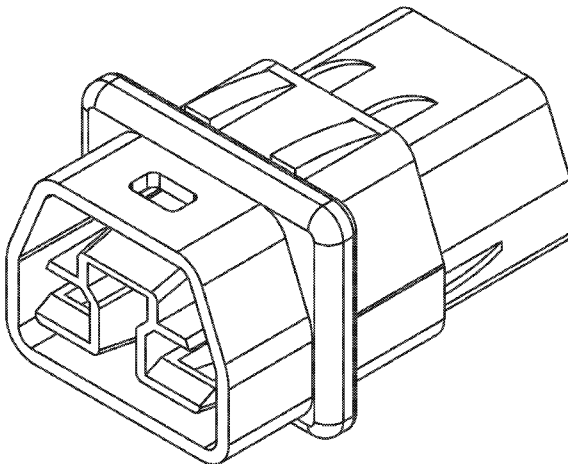

# US D626,073 S

Page 2

---

U.S. PATENT DOCUMENTS			
4,489,997	A *	12/1984	Byrne ..... 439/98
4,934,959	A	6/1990	Zielinski et al.
D317,899	S *	7/1991	Takenouchi et al. .... D13/133
D332,600	S	1/1993	Lucey et al.
D460,049	S *	7/2002	McCoy ..... D13/147
D493,428	S *	7/2004	McCoy ..... D13/147
7,074,070	B1 *	7/2006	Huang et al. .... 439/352
D604,249	S	11/2009	Mancini
2006/0276071	A1 *	12/2006	Rossi ..... 439/352
2007/0178739	A1	8/2007	Kuwayama
2009/0035981	A1	2/2009	Lim
			* cited by examiner

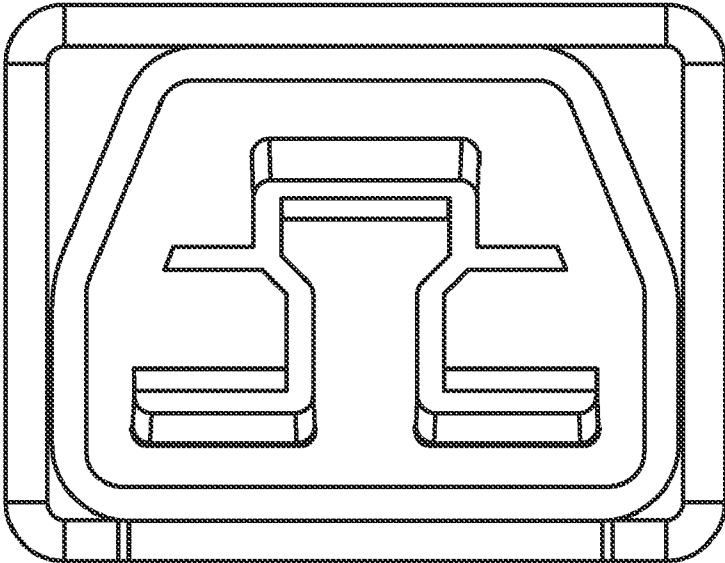

FIG. 1

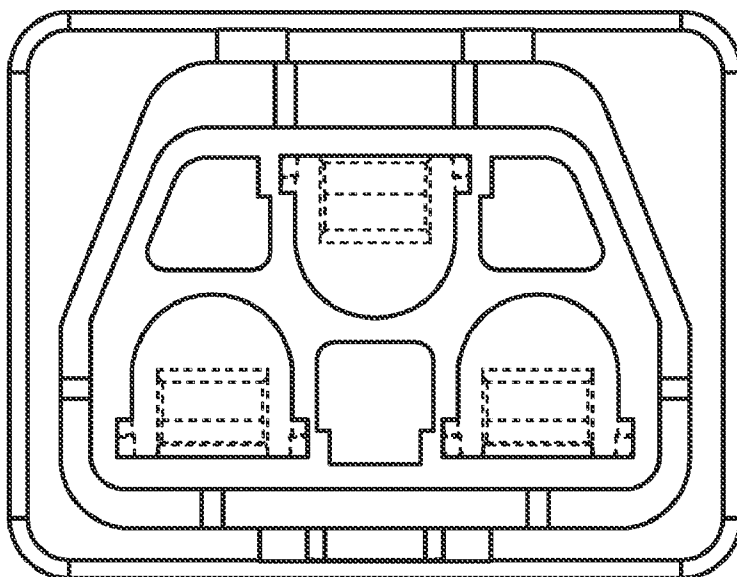

FIG. 2

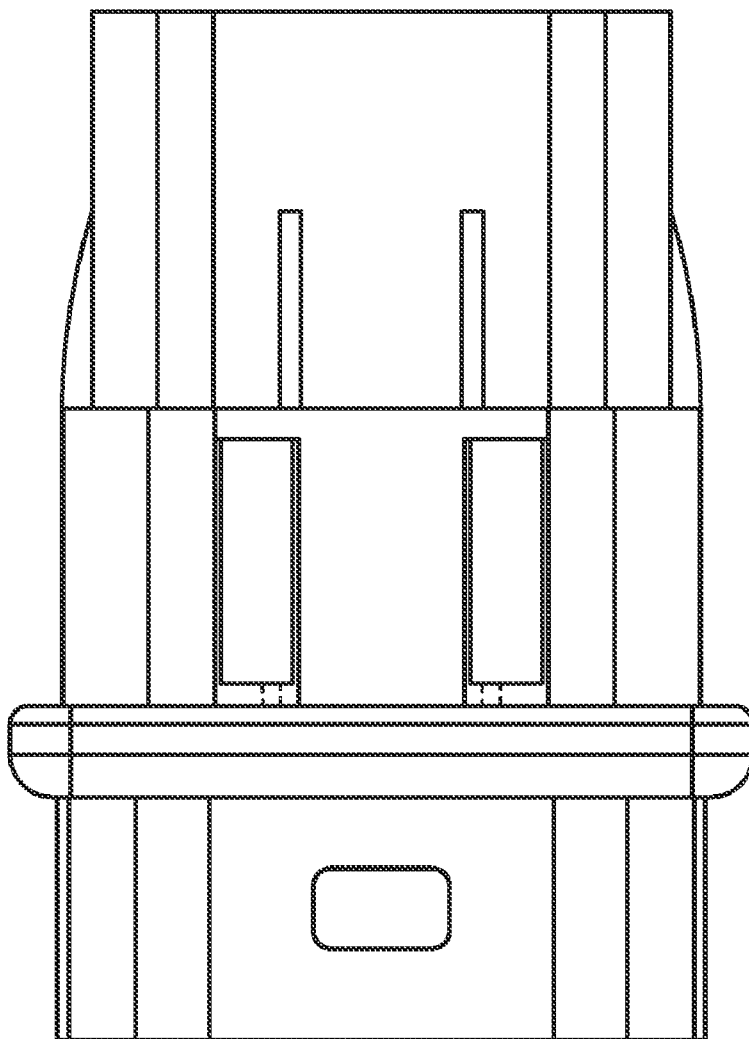

FIG. 3

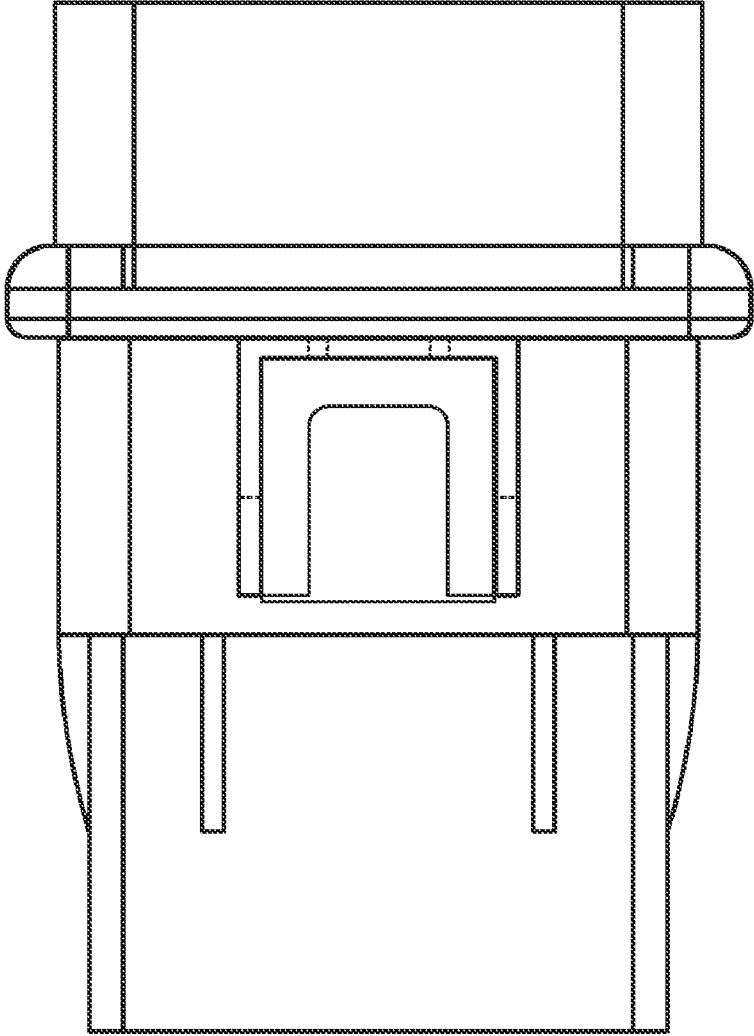

FIG. 4

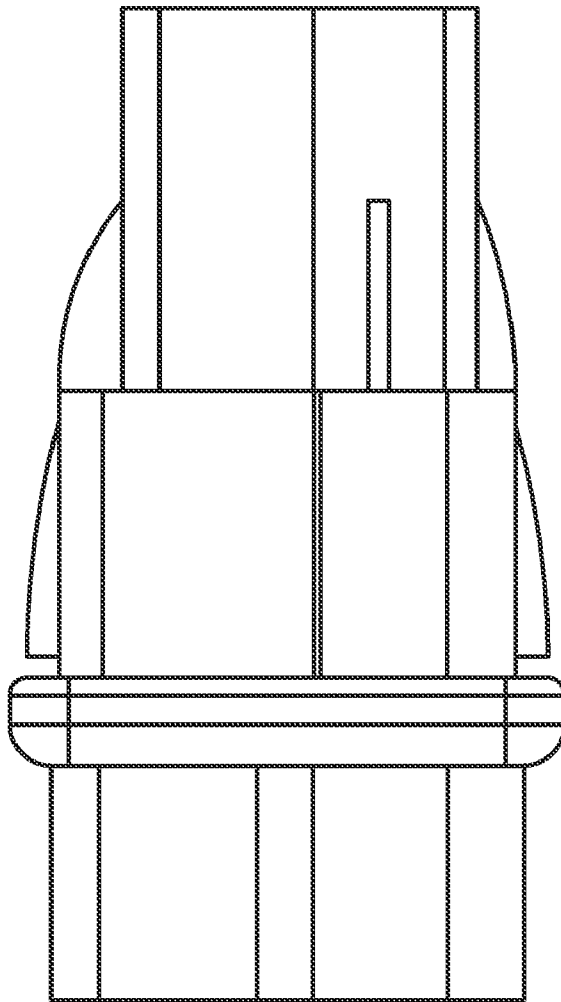

FIG. 5

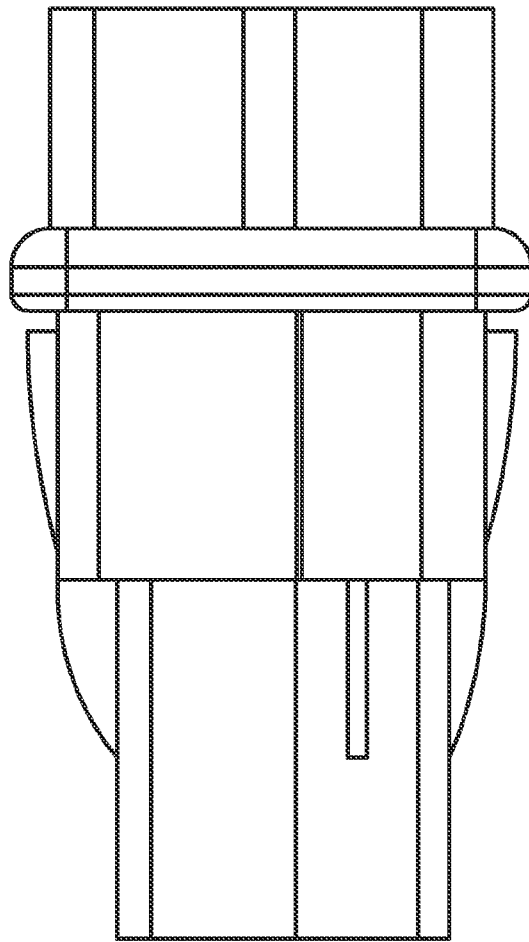

FIG. 6



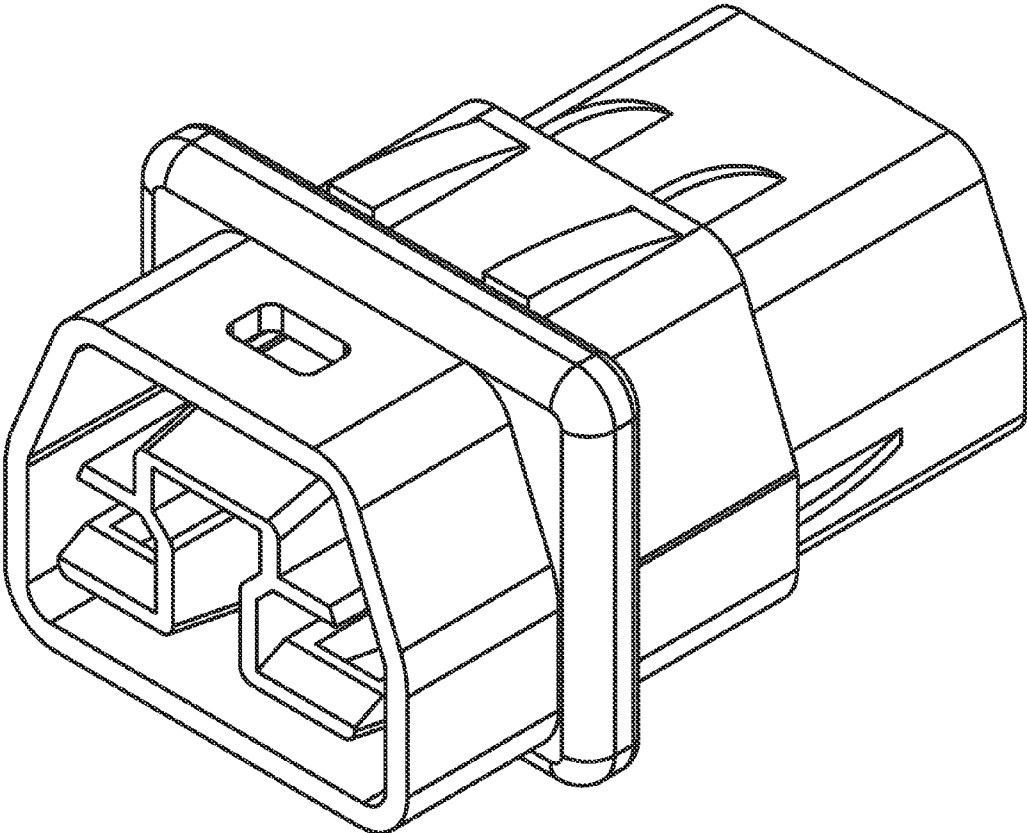

FIG. 7

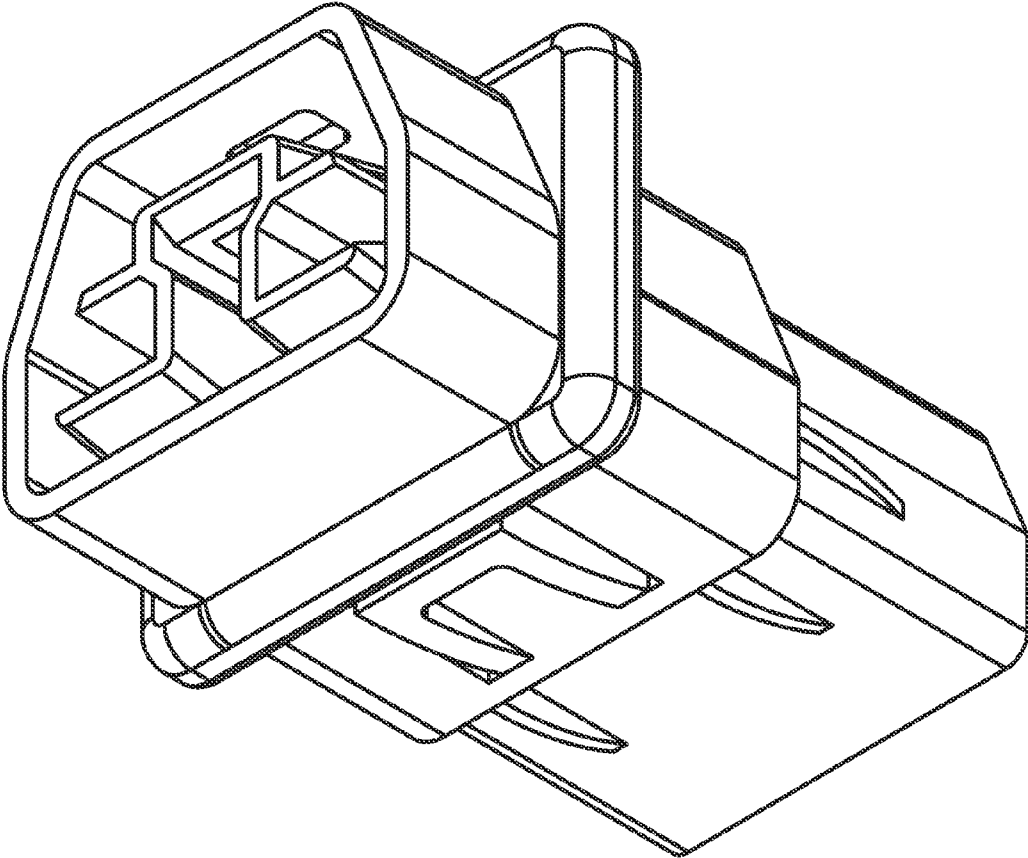

FIG. 8

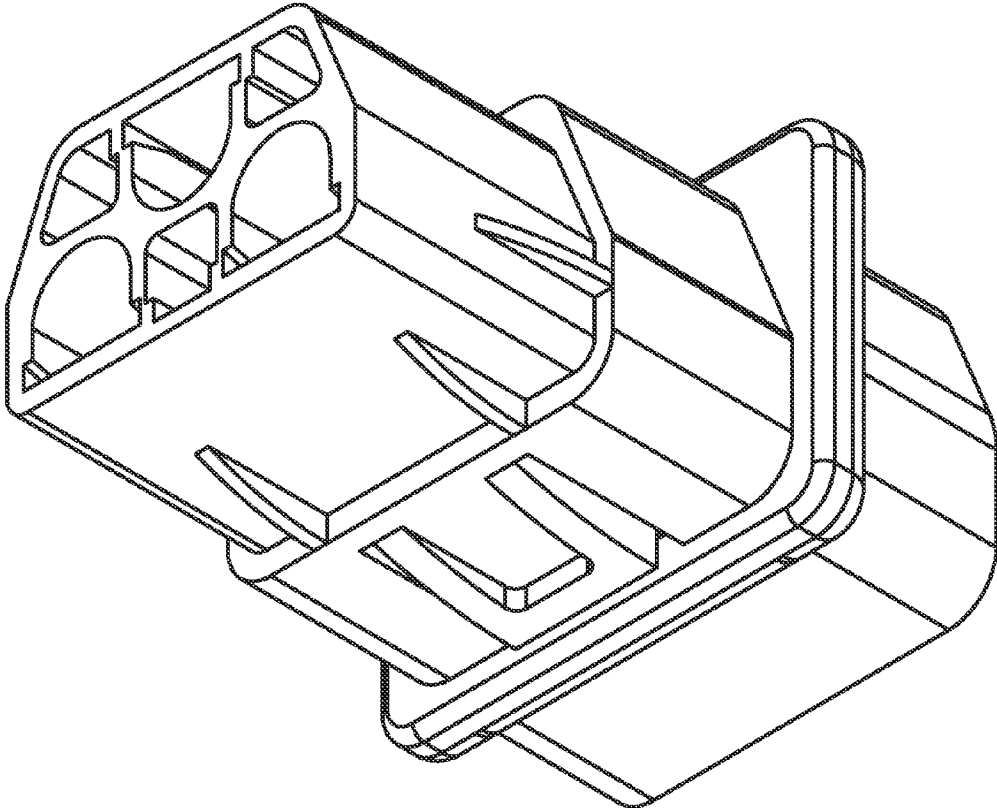

FIG. 9

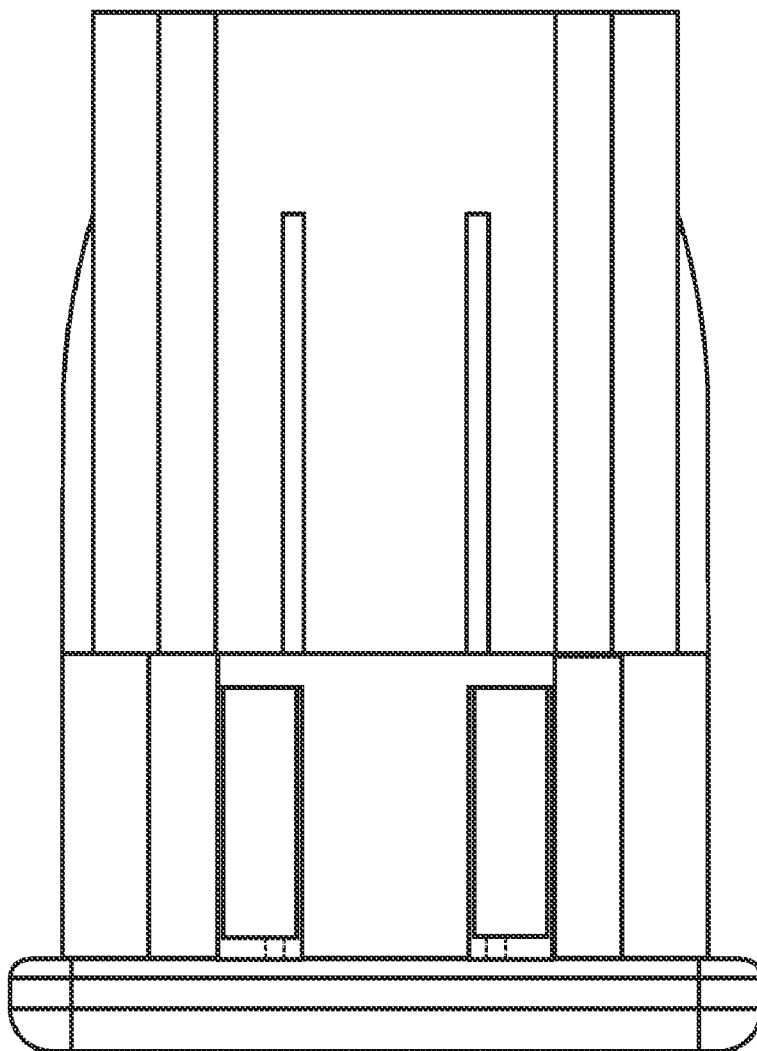

FIG. 10

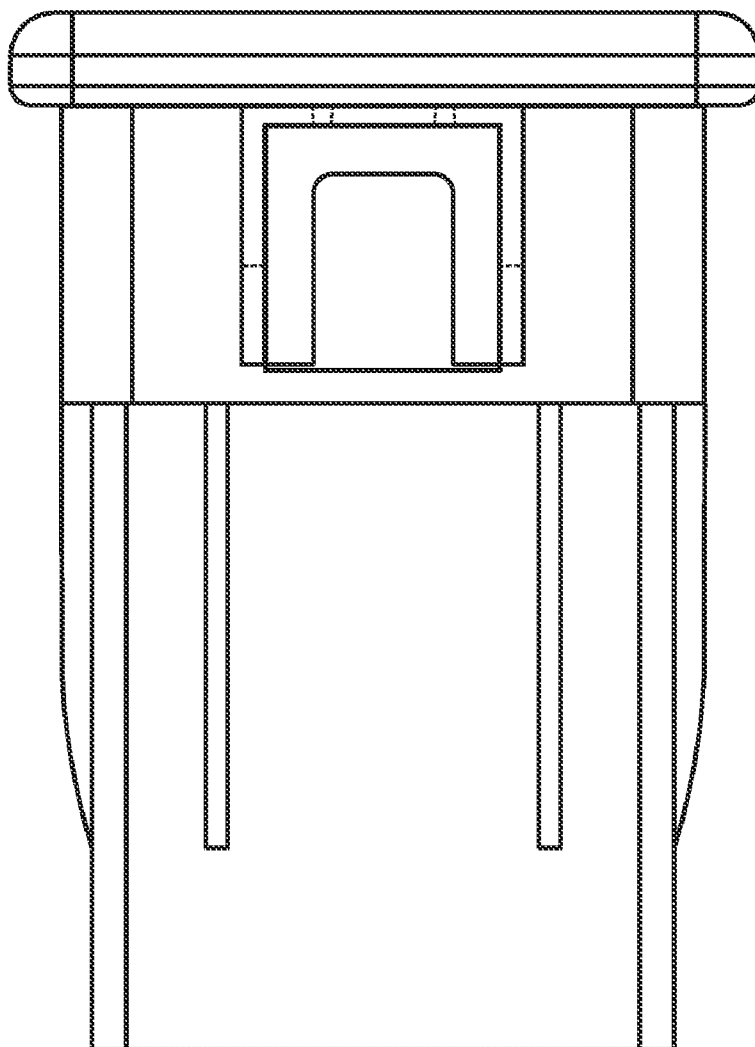

FIG. 11

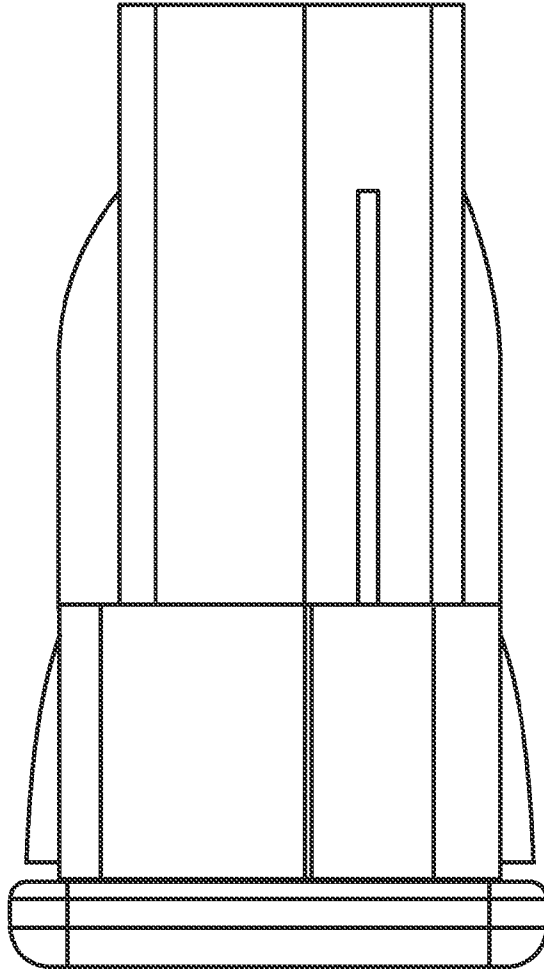

FIG. 12

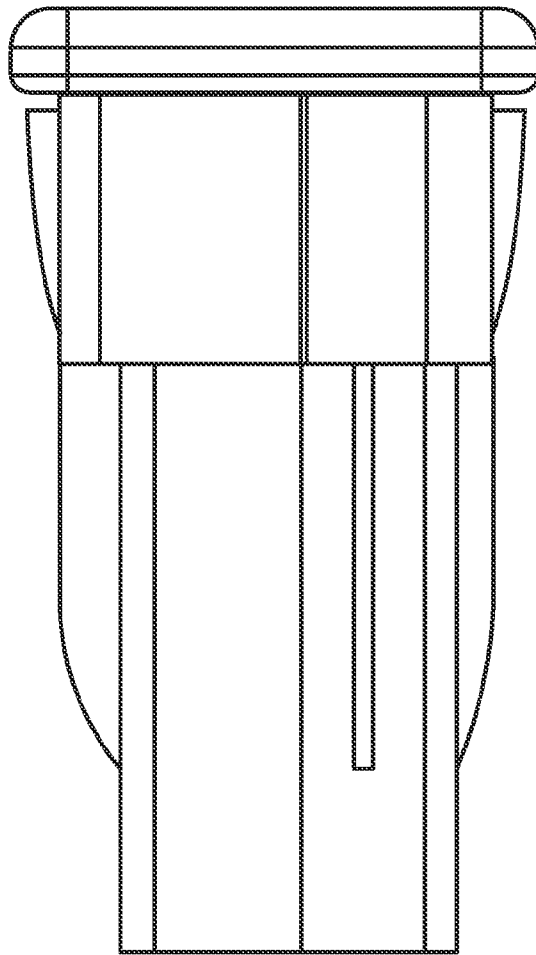

FIG. 13

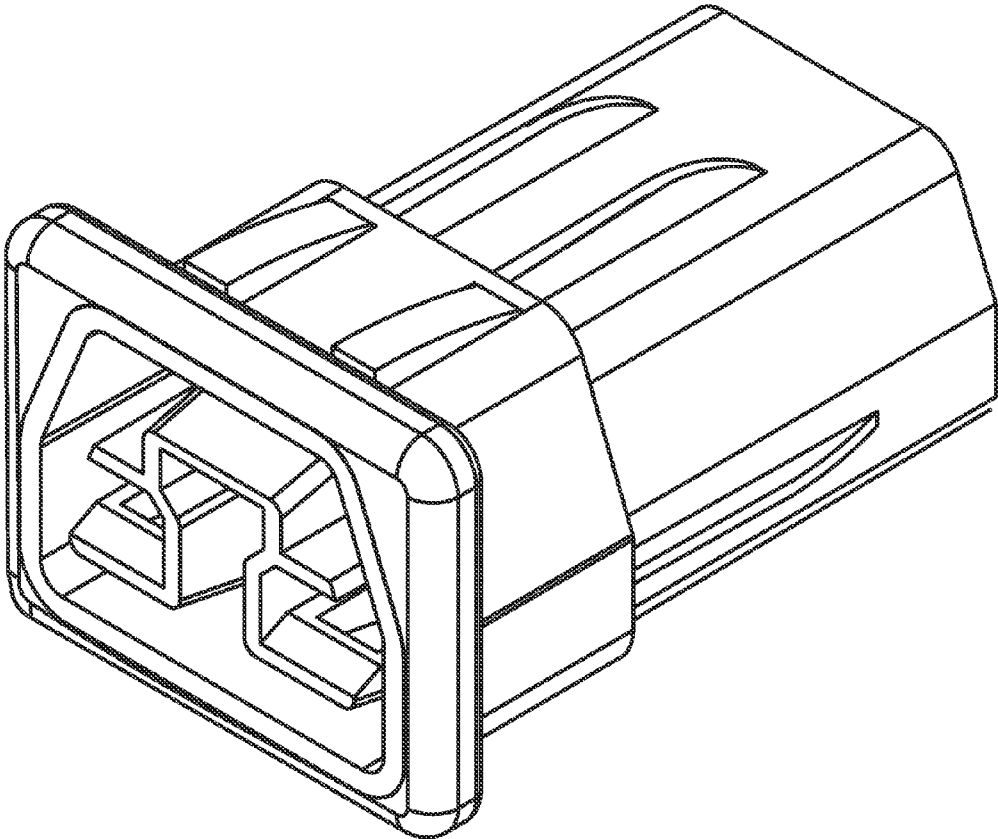

FIG. 14



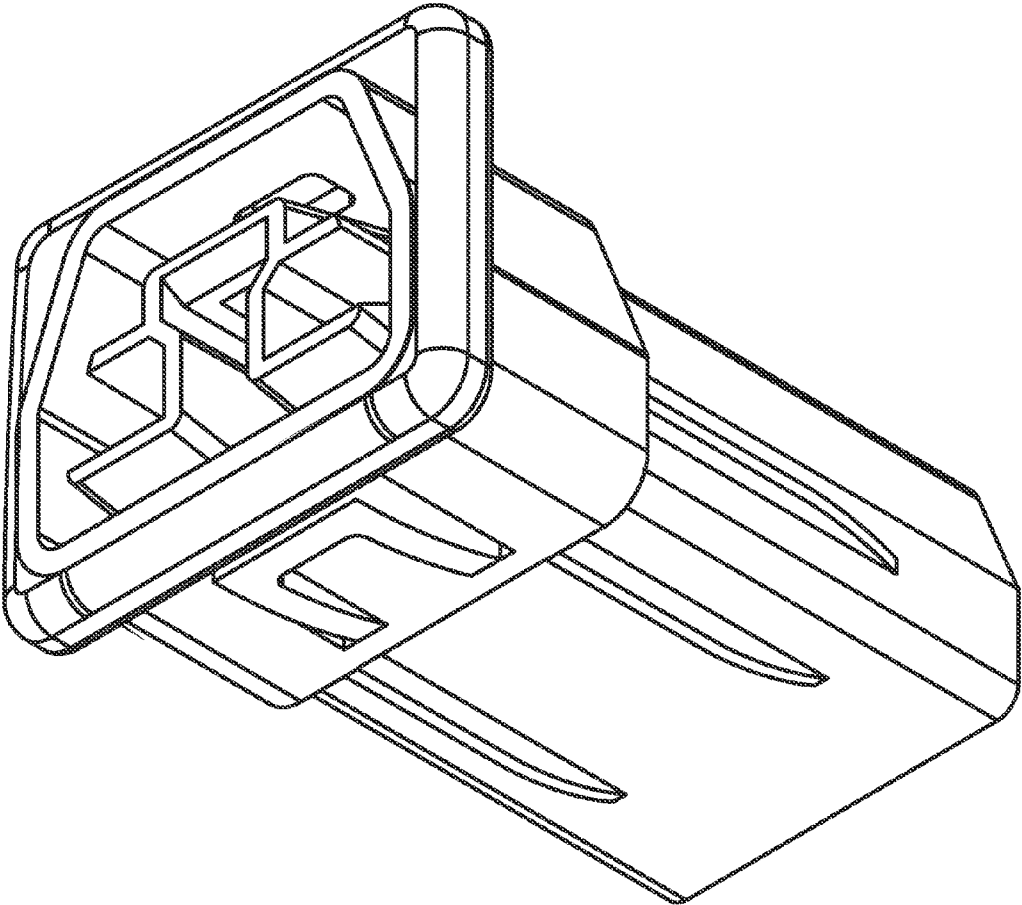

FIG. 15

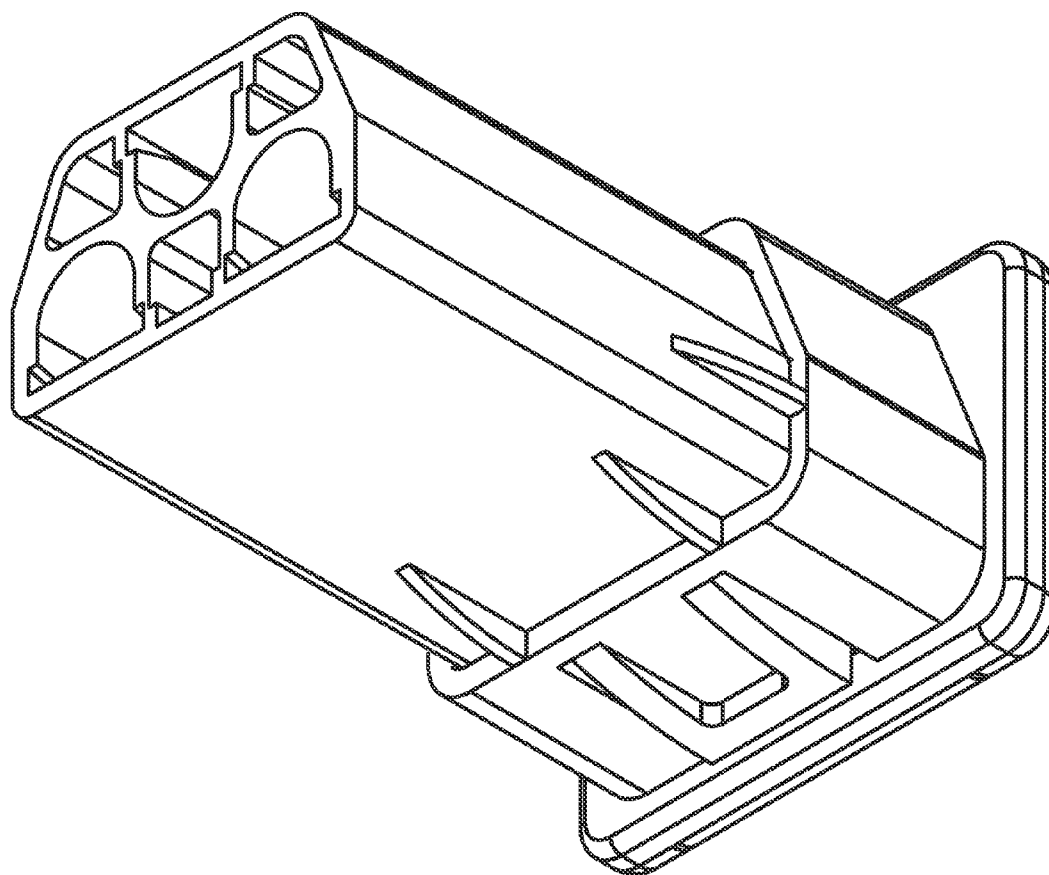

FIG. 16

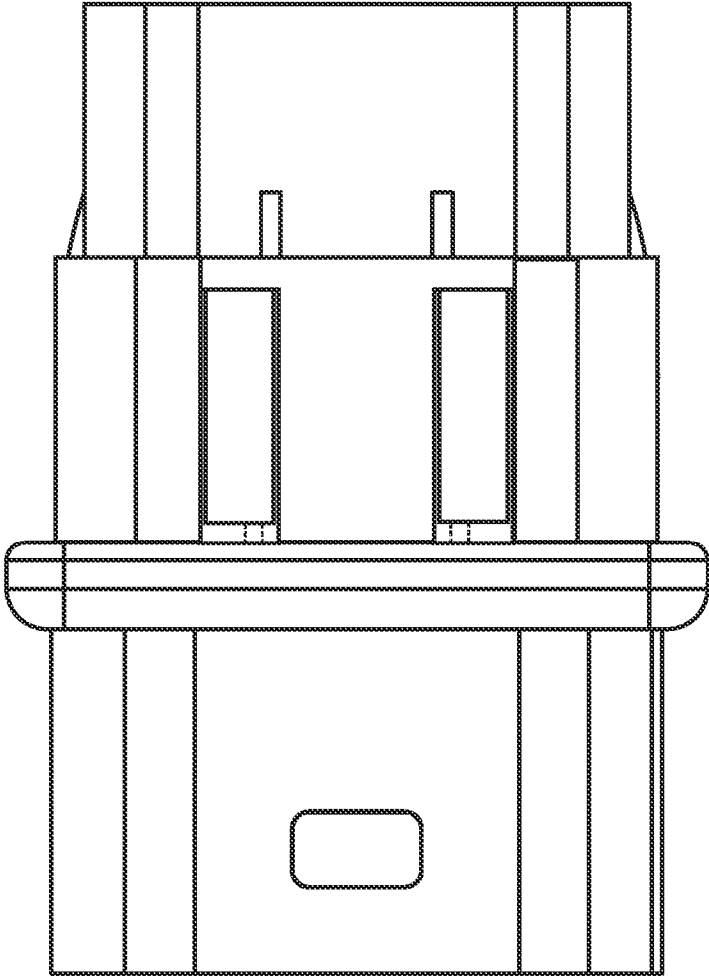

FIG. 17

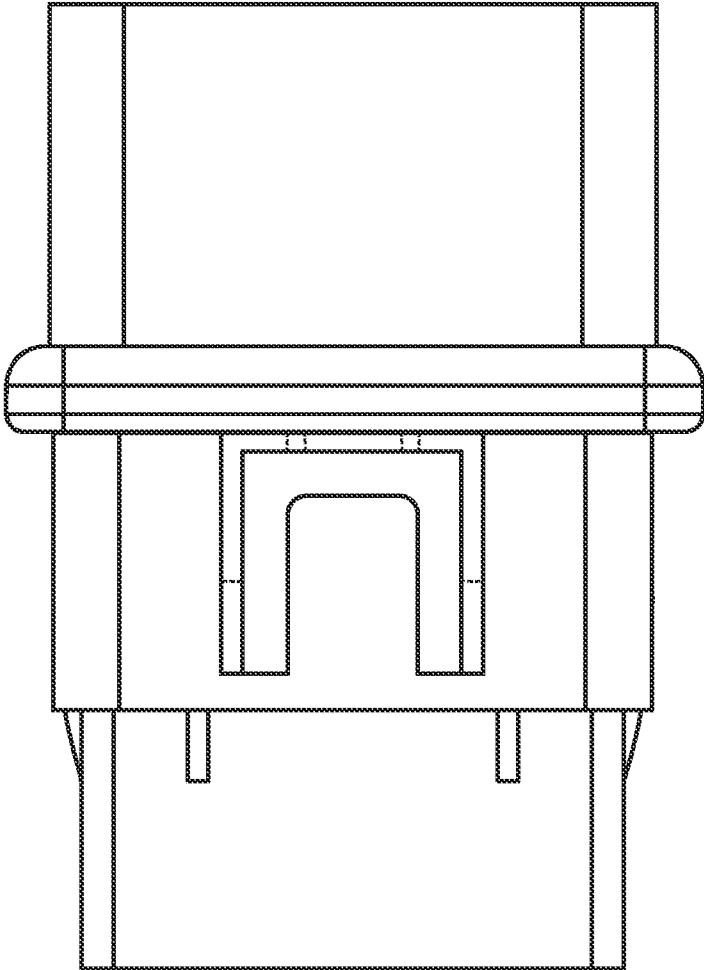

FIG. 18

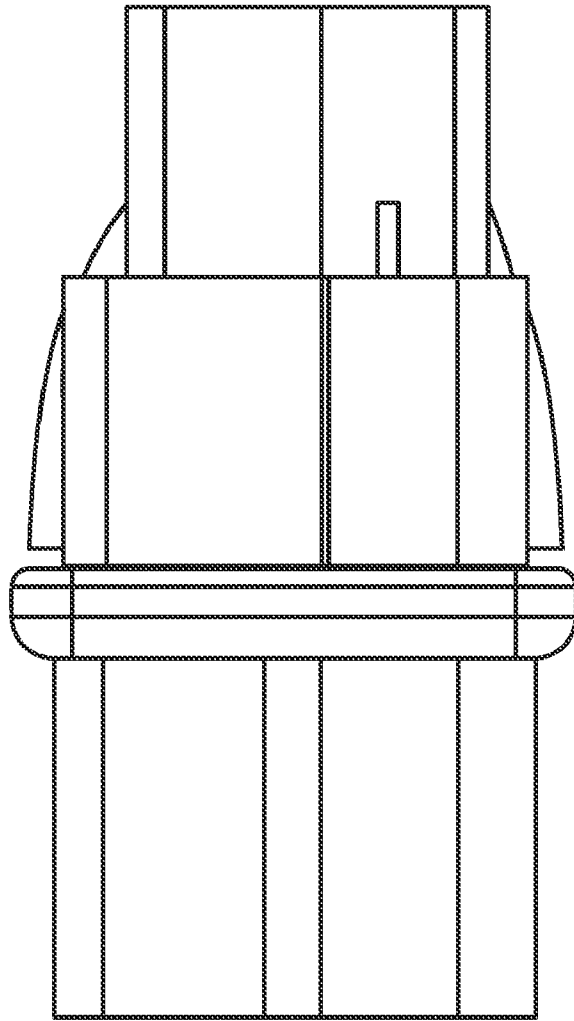

FIG. 19

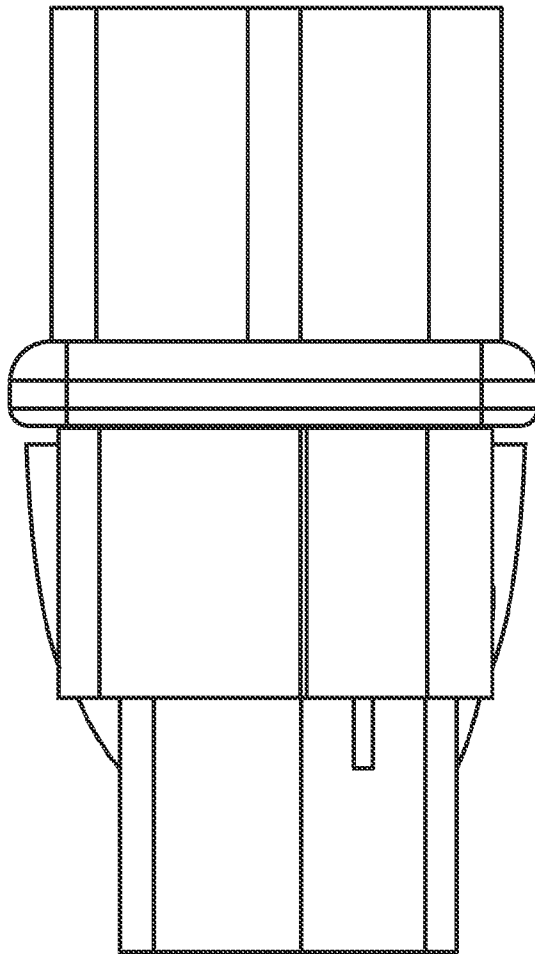

FIG. 20

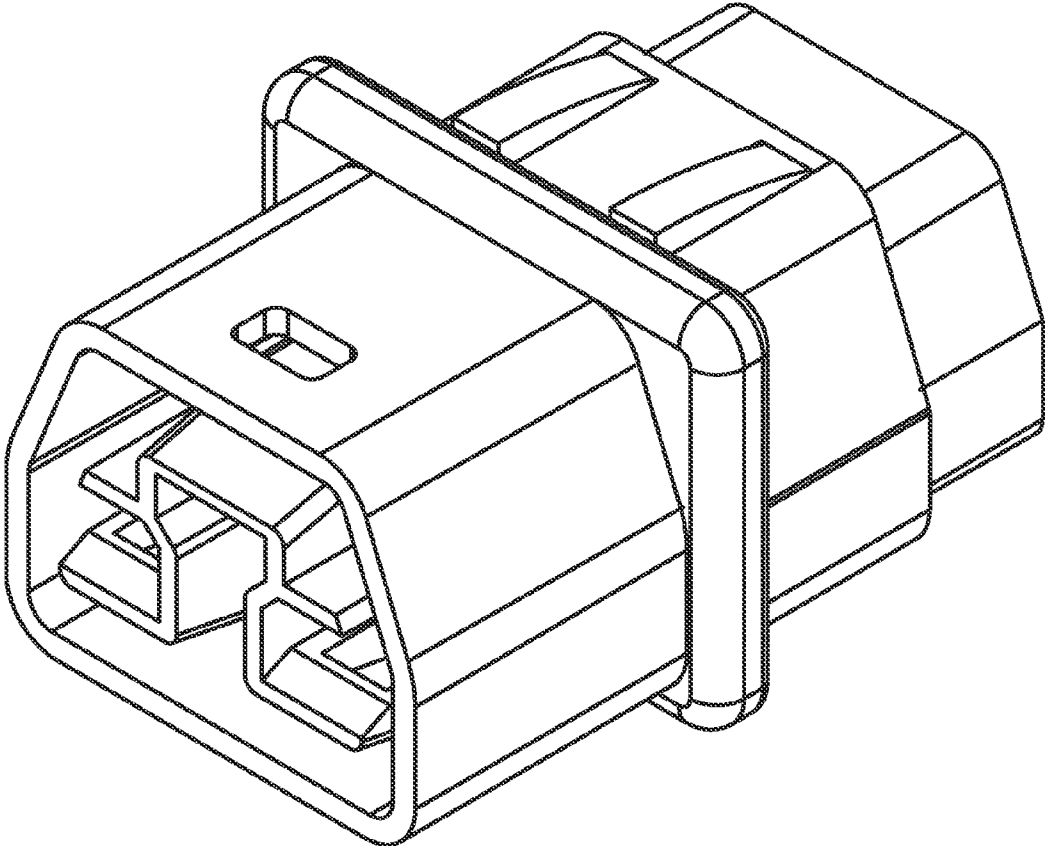

FIG. 21

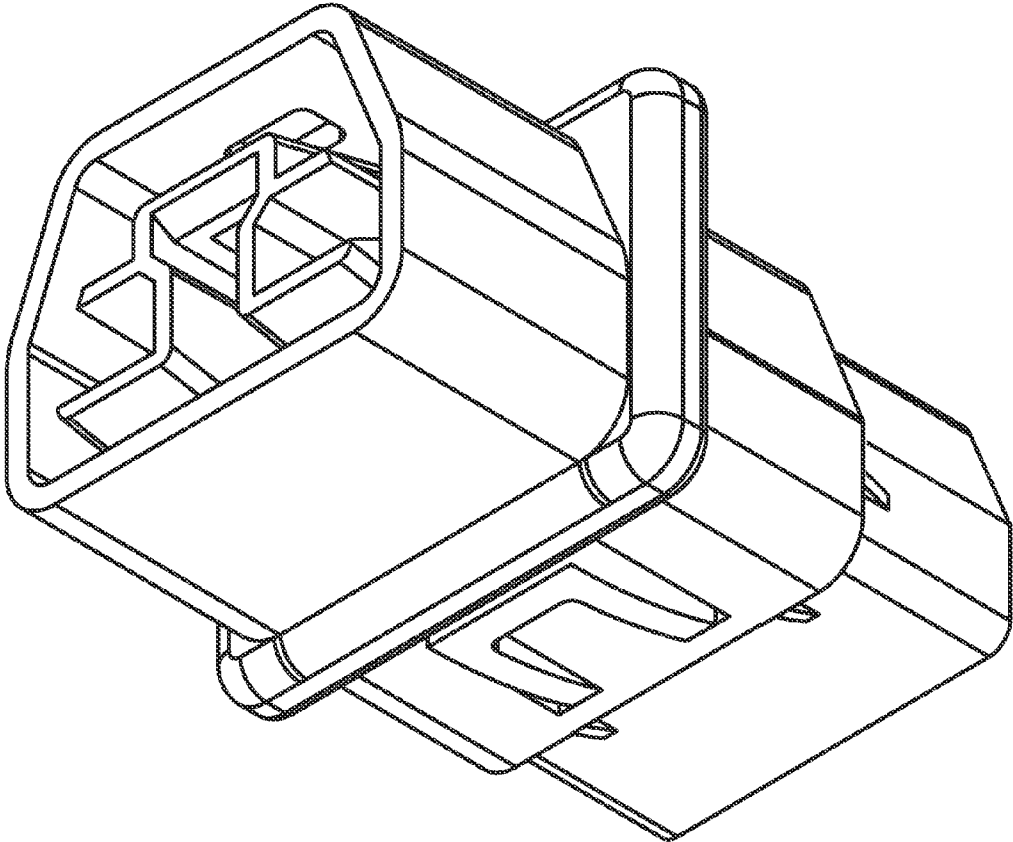

FIG. 22



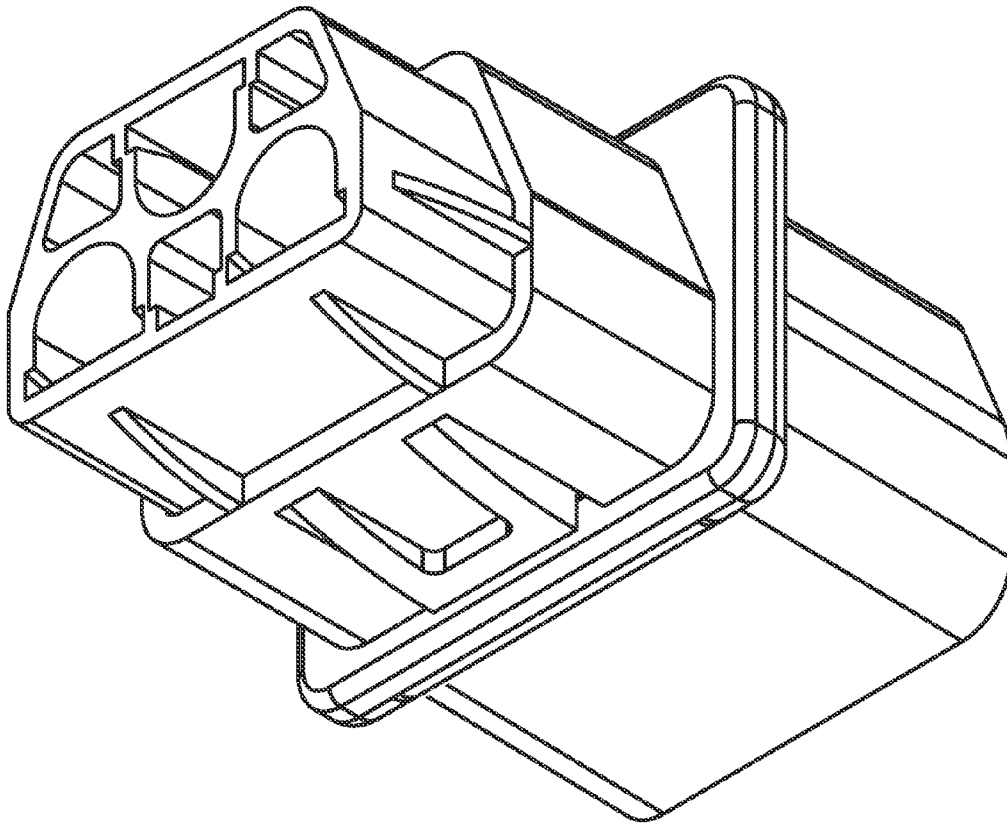

FIG. 23

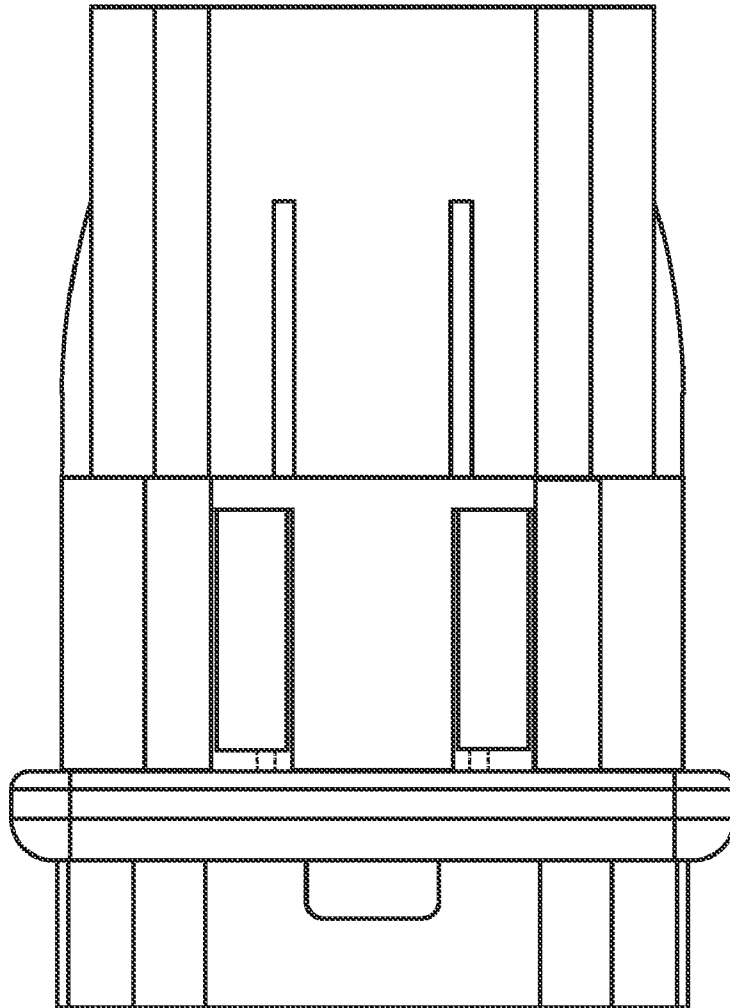

FIG. 24

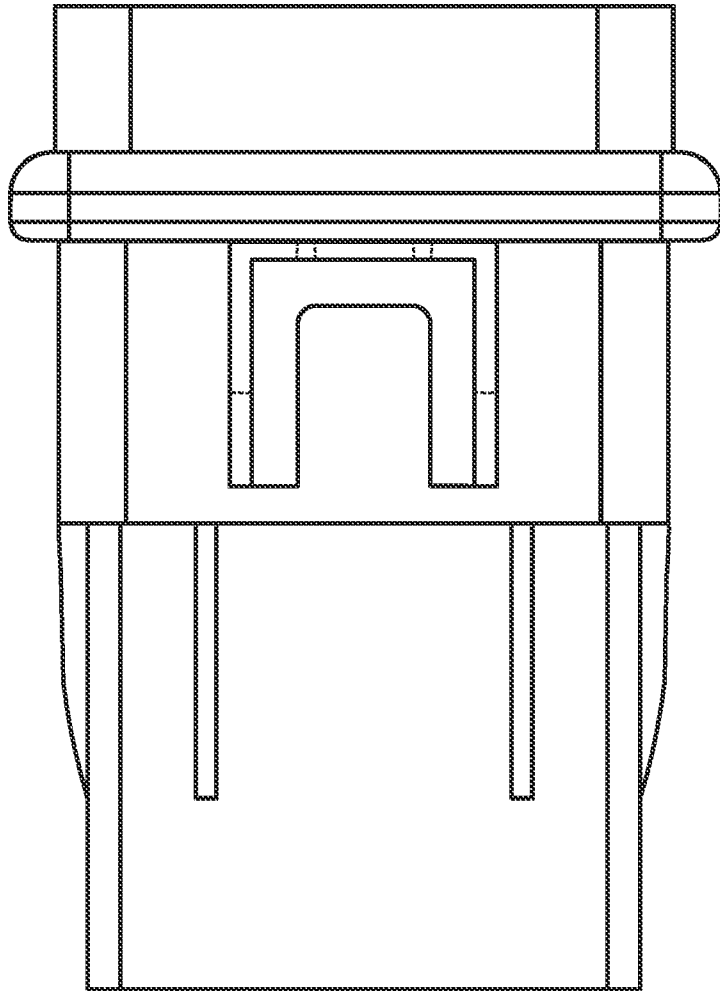

FIG. 25

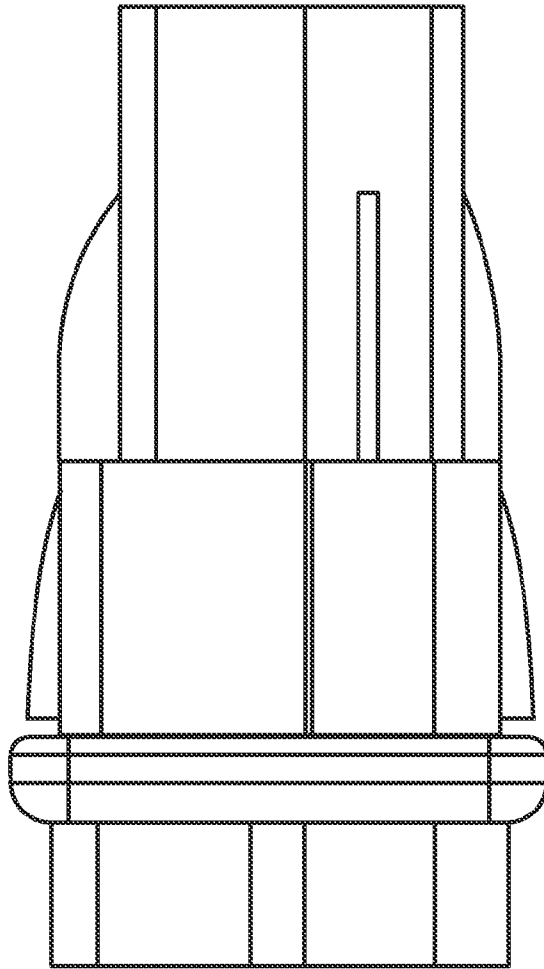

FIG. 26

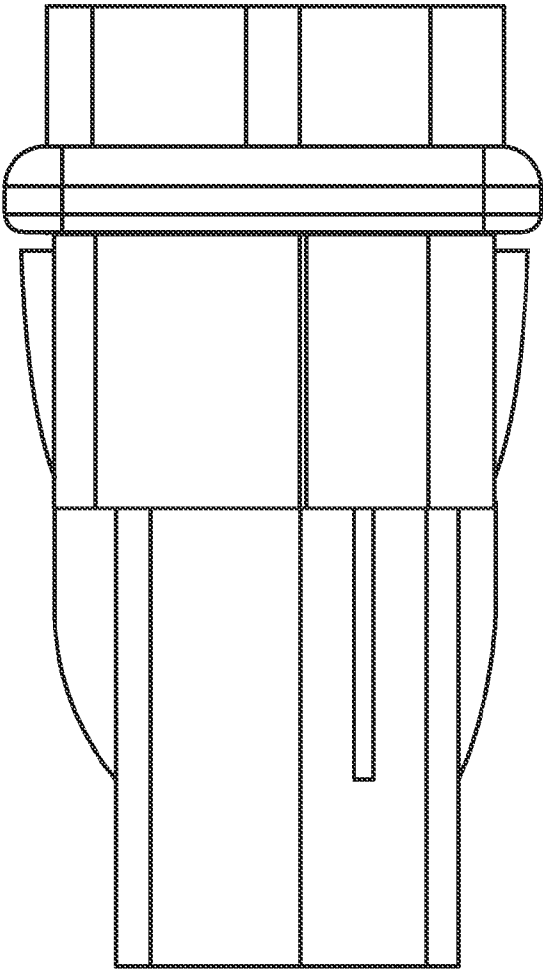

FIG. 27

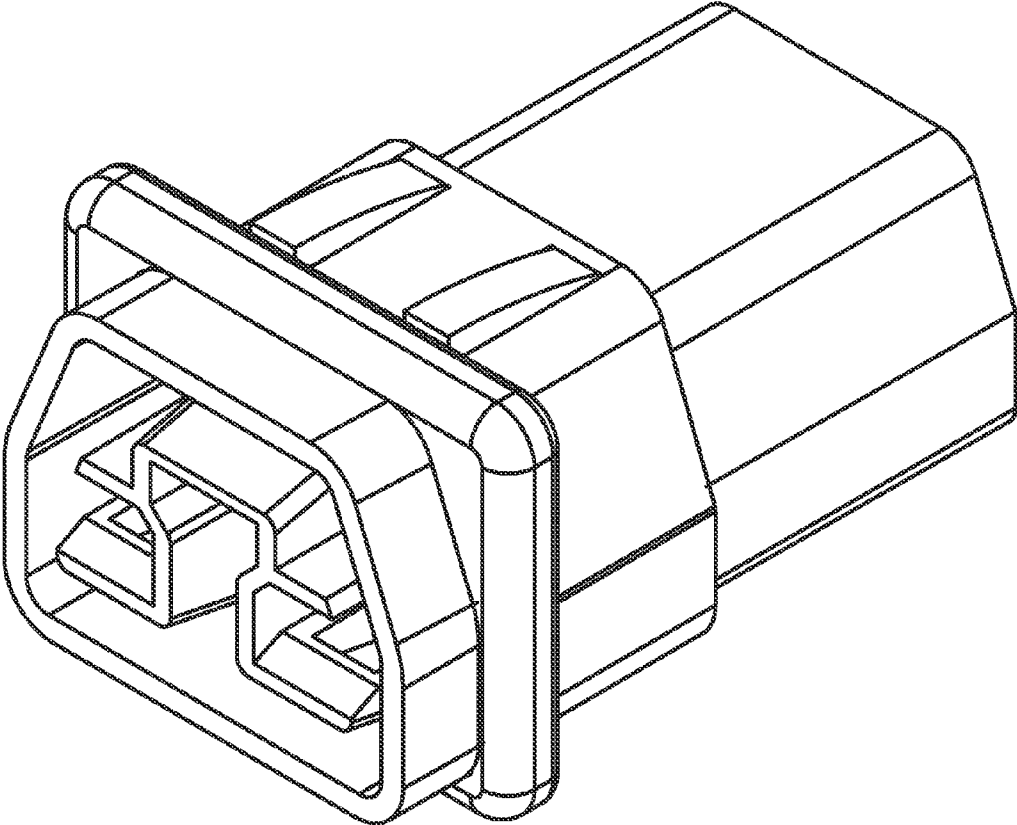

FIG. 28

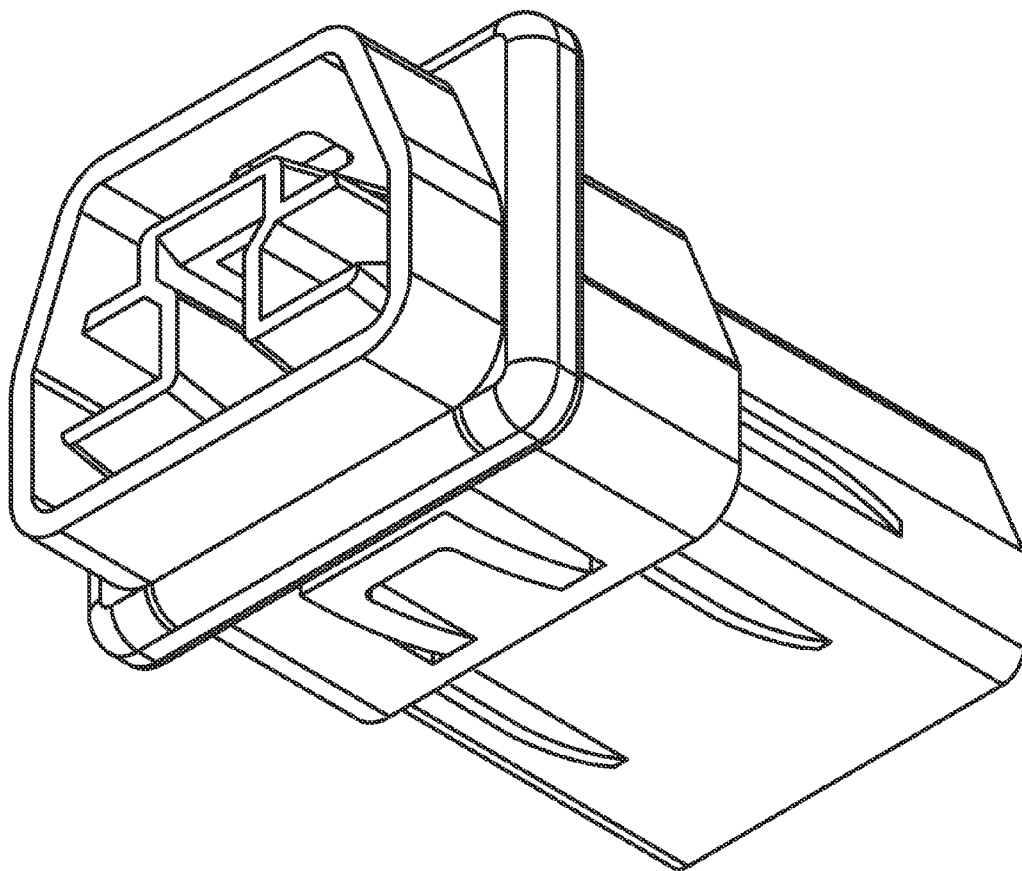

FIG. 29

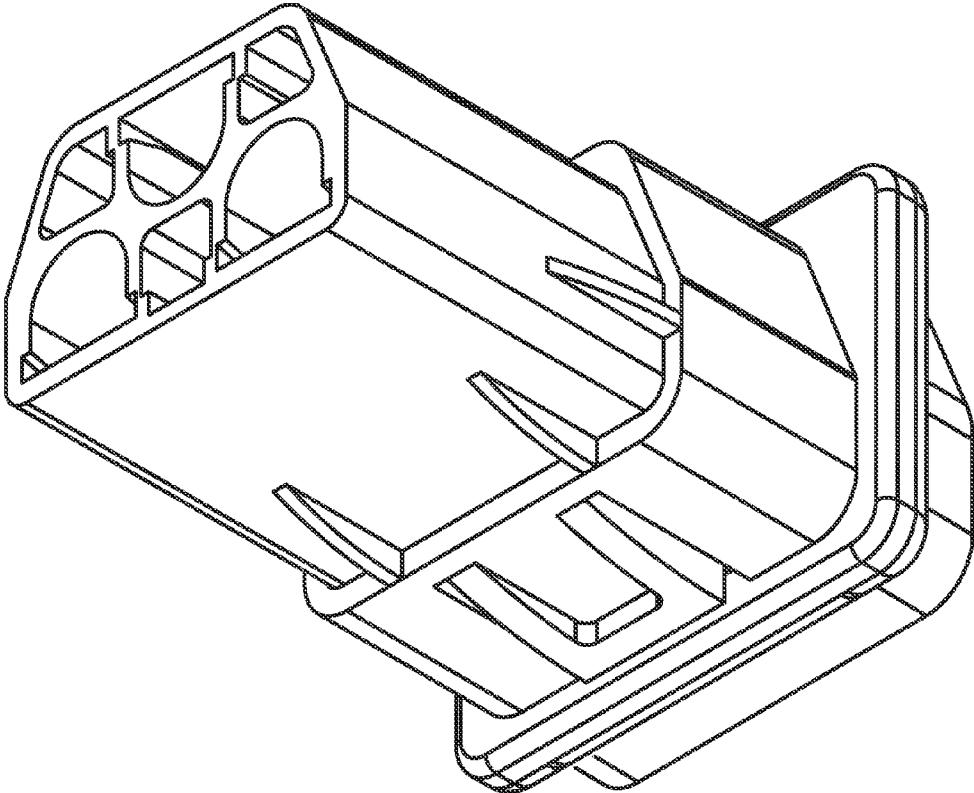

FIG. 30