

E. BURK.  
 ELEVATING DEVICE.  
 APPLICATION FILED AUG. 14, 1908.

916,267.

Patented Mar. 23, 1909.

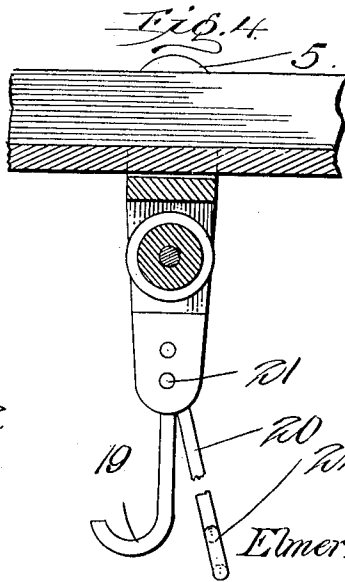
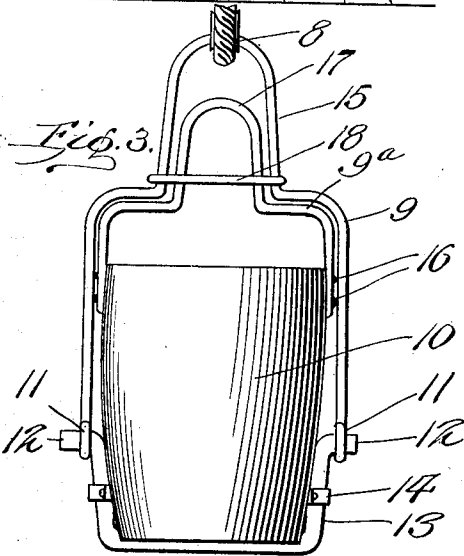
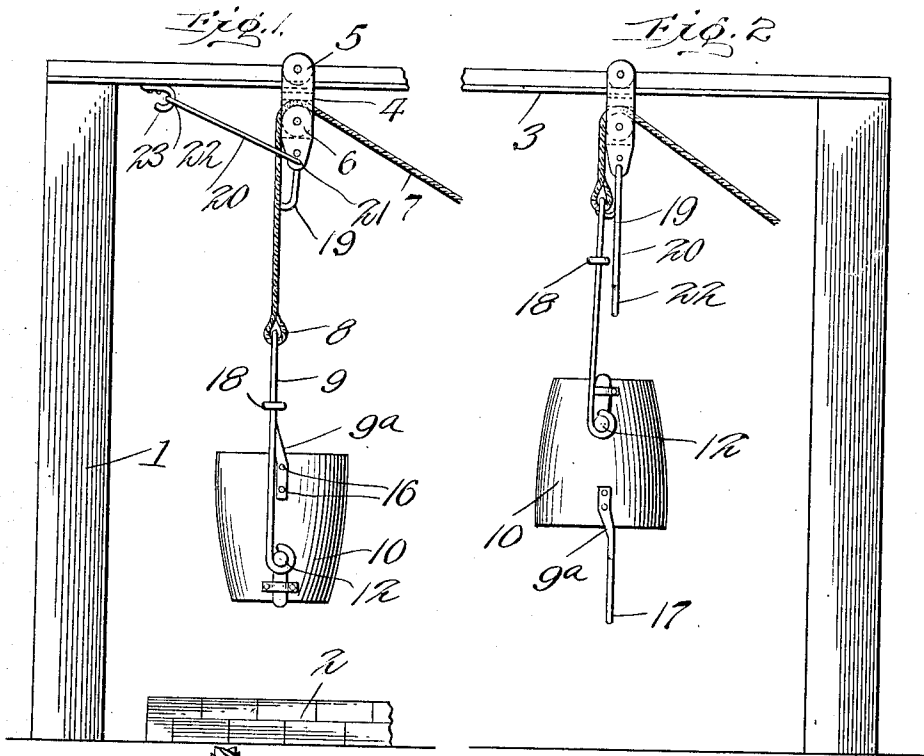

Witnesses  
*A. Griffith*  
*C. B. Myers*

Inventor  
*Elmer Burk*,  
 By *Victor J. Evans*  
 Attorney

# UNITED STATES PATENT OFFICE.

ELMER BURK, OF TOLONA, MISSOURI.

## ELEVATING DEVICE.

No. 916,267.

Specification of Letters Patent.

Patented March 23, 1909.

Application filed August 14, 1908. Serial No. 448,575.

*To all whom it may concern:*

Be it known that I, ELMER BURK, a citizen of the United States of America, residing at Tolona, in the county of Lewis and State of Missouri, have invented new and useful Improvements in Elevating Devices, of which the following is a specification.

This invention relates to elevating devices designed for the purpose of removing dirt from wells, but capable of many other uses, and one of the principal objects of the same is to provide an elevating bucket which can be readily inverted to discharge its contents, said bucket being connected to a pulley by a cable, said pulley being mounted upon a rail.

Another object of the invention is to provide simple and reliable means for elevating dirt or water and for carrying it off at a distance and discharging the same.

These and other objects may be attained by means of the construction illustrated in the accompanying drawing, in which,—

Figure 1 is a side elevation of an elevating device made in accordance with my invention, said elevating device shown in its loaded position. Fig. 2 is a similar view, showing the bucket inverted to discharge its contents. Fig. 3 is a detail side elevation of the bucket and its bails connected together by the trip ring. Fig. 4 is a detail section of the pulley and its connected parts.

Referring to the drawing, the numerals 1 designate a pair of posts, one of which is located near a well curbing 2, while the other is located at such distance therefrom as will permit the loaded bucket to be carried to a place for discharging its contents away from the well. Secured to the top of the post 1 is a rail consisting of an angle iron or T-bar 3. Mounted on the rail or track 3 is a traveling pulley block 4 provided with traction wheels 5 supported upon the base flange or flanges of the rail 3. A grooved pulley roller 6 is journaled in the pulley block, and extending around this pulley is a rope or cable 7, one end of which is secured at 8 to the pivoted bail 9 of the bucket 10. The bail 9 is provided with pintle bearings 11 which loosely engage the outwardly extending pintles 12 formed on a yoke 13 secured by metal straps 14 near the bottom of the bucket 10. The upper portion of the bail 9 is brought together to form a loop 15 in which the rope or cable 7 is secured. An inner bail 9<sup>a</sup> is

riveted to the bucket 10 at its lower ends, as at 16. The upper portion of the bail 9<sup>a</sup> is formed into a loop 17 smaller than the loop 15 and adapted to be held in vertical alignment therewith by means of a trip ring 18 which slides on the loops 15 and 17, as shown in Fig. 3 to hold the bucket upright. When the ring 18 is slipped above the loop 17 the bucket 10 is by gravity inverted to the position shown in Fig. 2 to discharge its contents.

Connected to the pulley block 4 is a hook 19 which engages the loop 15 of the bail 9 when the bucket has been hoisted and is ready to be carried to its place of discharge. In order to hold the pulley against moving on the track while the bucket is being hoisted, a latch 20 is pivoted at 21 to the pulley, and the opposite end of said latch is provided with a loop 22 adapted to be engaged by a hook 23 secured under the track.

The operation of my invention may be briefly described as follows:—When the bucket 10 is to be let down into the well, the trip ring 18 engages the loops 15 and 17 of the bails to hold the bucket upright. The latch 20 is engaged with the hook 23. The rope or cable 7 may be operated either by hand or by a draft animal, depending upon the weight of the loaded bucket. After the bucket has been raised above the well 2, the hook 19 is engaged with the loop 15 of the bail 9, and the loop 22 is disengaged from the hook 23. In this condition the bucket and pulley block 4 are drawn over the track 3 to the place of discharge, and as the trip ring 18 is raised by hand above the loop 17, the bucket is inverted by gravity and its contents discharged. The bucket is then moved back to the well and the same operation repeated.

From the foregoing, it will be obvious that an elevating device made in accordance with my invention is of simple construction, can be quickly erected and arranged in position for use, is reliable and efficient, cannot readily get out of order and can be constructed at low cost.

I claim:—

1. An elevating device comprising a bucket provided with a pivoted bail and a rigid bail, a trip ring for holding said bails in alignment, a pulley block, a track, a cable connected to the pivoted bail of the bucket and extending over a roller in the pulley block,

a hook connected to the pulley block for supporting the bail of the bucket, and a latch for holding the pulley block against movement upon the track.

- 5 2. An elevating device comprising a bucket, means whereby said bucket may discharge its contents by gravity, said means comprising a rigid bail, a pivoted bail and a trip ring, said ring engaging said bails for  
10 holding said bucket upright when loaded, a pulley block, a cable connected to the bucket

and passing over the pulley, a traction roller on the pulley block, a supporting hook on the pulley block, and a latch pivoted to the pulley for holding said pulley block against  
15 movement upon the track.

In testimony whereof I affix my signature in presence of two witnesses.

ELMER BURK.

Witnesses:

J. A. BUCKLEY,  
BERTIE CASON.