

E. G. HOFFMANN.  
MACHINE FOR GRINDING BALLS.

(Application filed Apr. 4, 1901.)

(No Model.)

4 Sheets—Sheet 1.

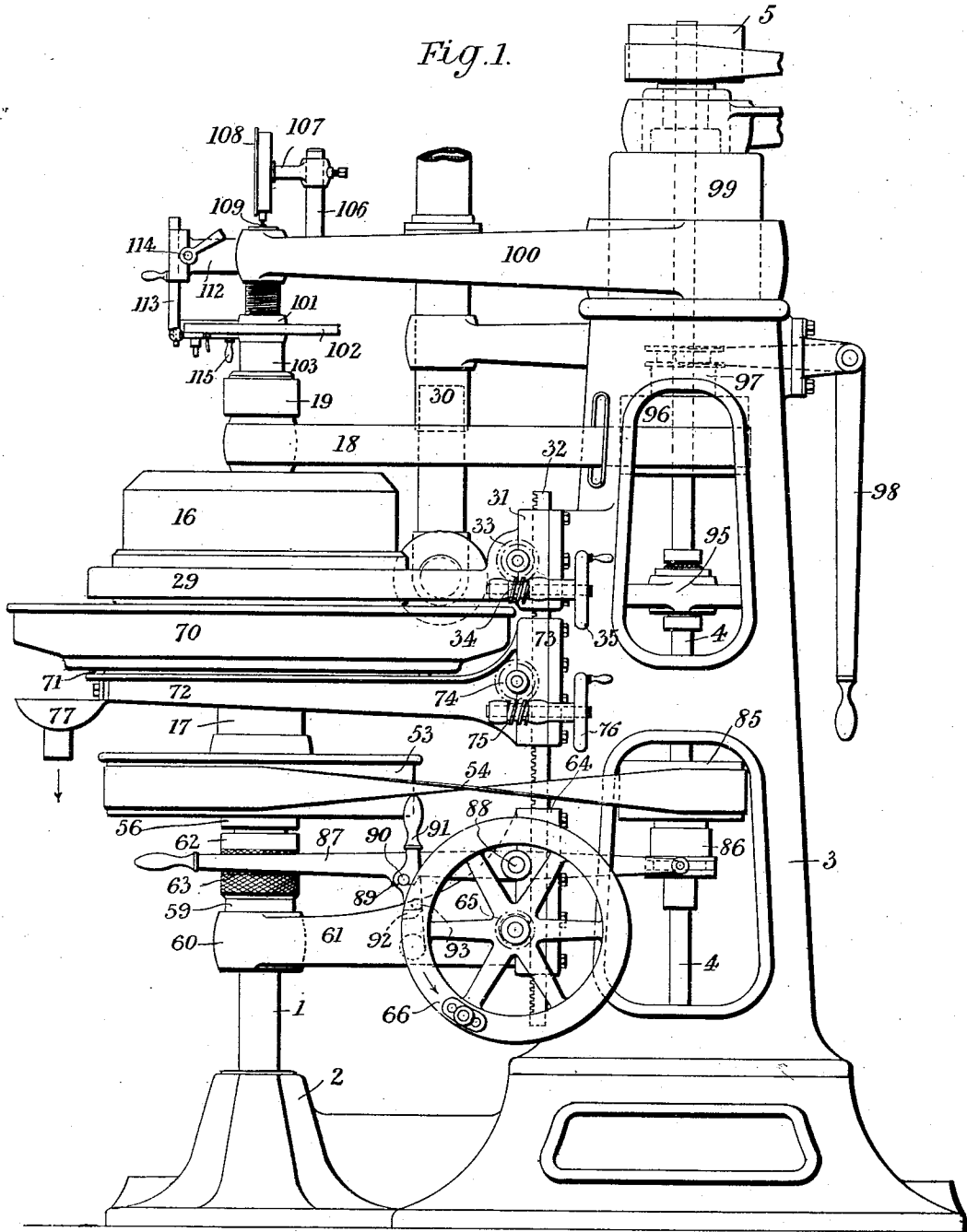

WITNESSES.  
*Lucius E. Vamey,*  
*A. H. Jesbera*

INVENTOR.  
*Ernst Gustav Hoffmann*  
*by Redding, Kiddle & Peckley*  
*Attys*

E. G. HOFFMANN.  
MACHINE FOR GRINDING BALLS.

(Application filed Apr. 4, 1901.)

(No Model.)

4 Sheets—Sheet 2.

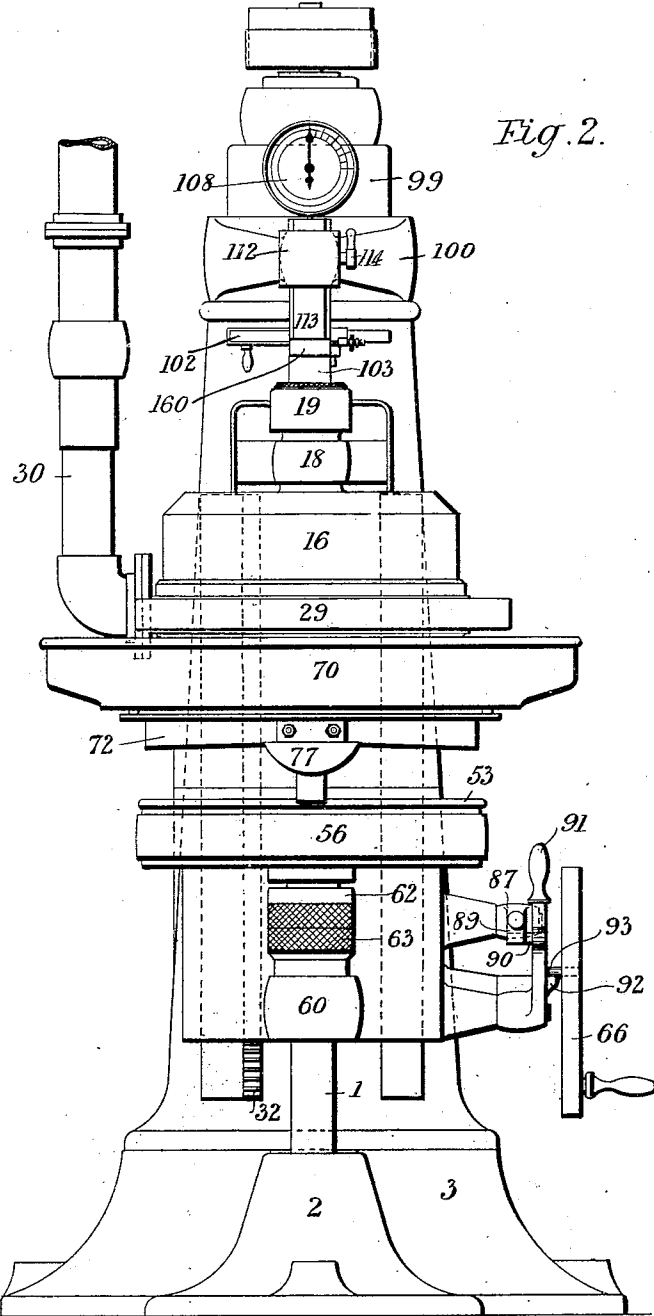

Fig. 2.

WITNESSES.  
*Lucius E. Ramey.*  
*A. St. Jester.*

INVENTOR.  
*Ernst Gustav Hoffmann*  
 by *Redding, Kidd & Greeley*  
 Attys

E. G. HOFFMANN.  
MACHINE FOR GRINDING BALLS.

(Application filed Apr. 4, 1901.)

(No Model.)

4 Sheets—Sheet 3.

Fig. 3.

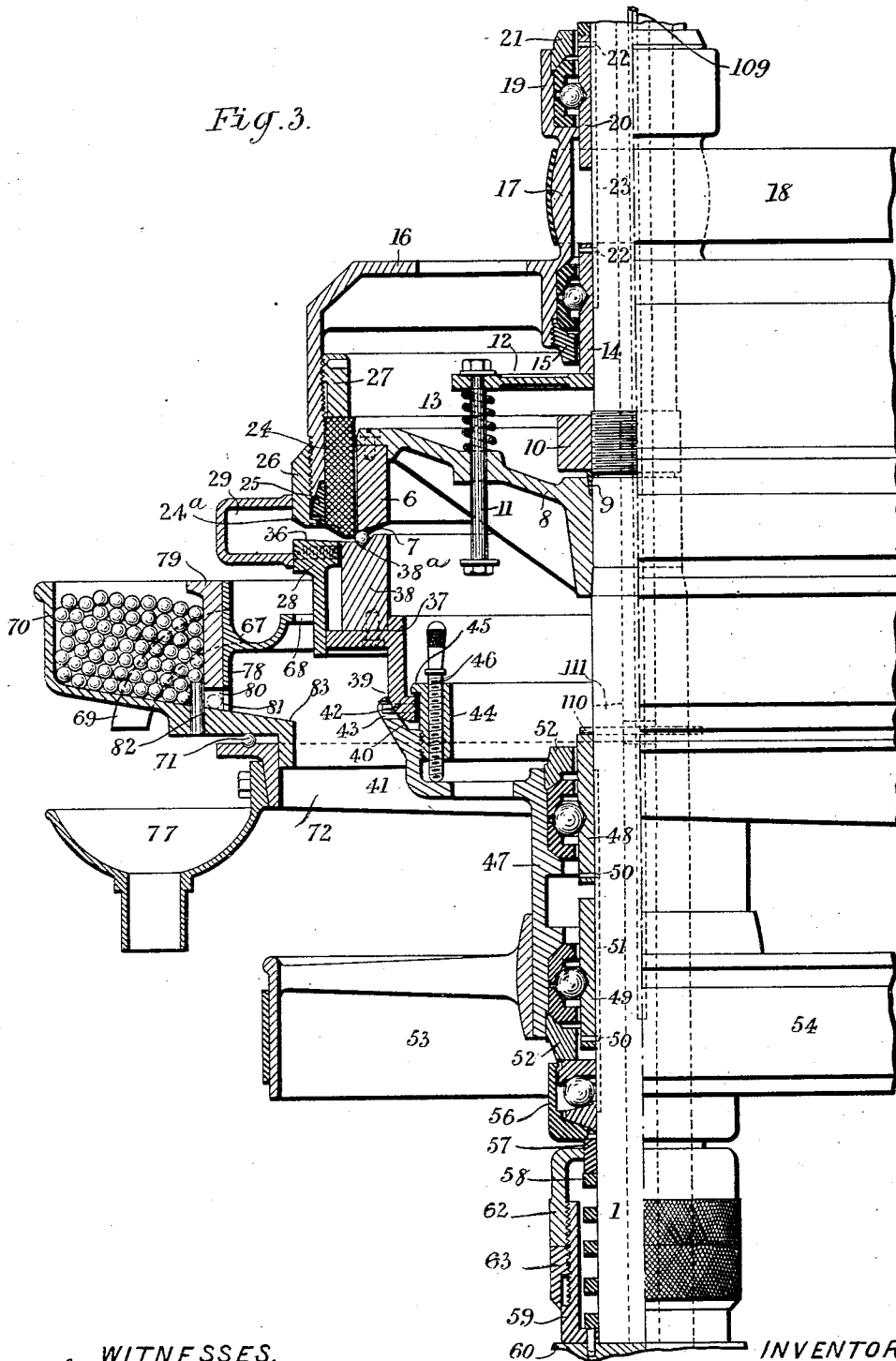

WITNESSES.  
*Lucius E. Vanney*  
*A. H. Jesbera*

INVENTOR.  
*Ernst Gustav Hoffmann*  
 by *Redding, Kidd & Kelley*  
*Attys*

E. G. HOFFMANN.  
MACHINE FOR GRINDING BALLS.

(Application filed Apr. 4, 1901.)

(No Model.)

4 Sheets—Sheet 4.

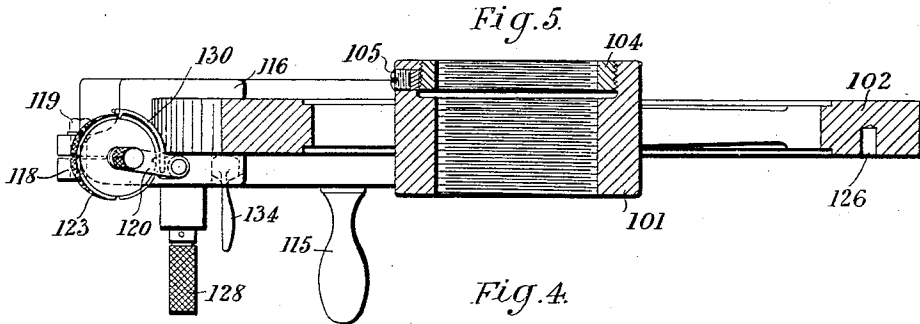

Fig. 4.

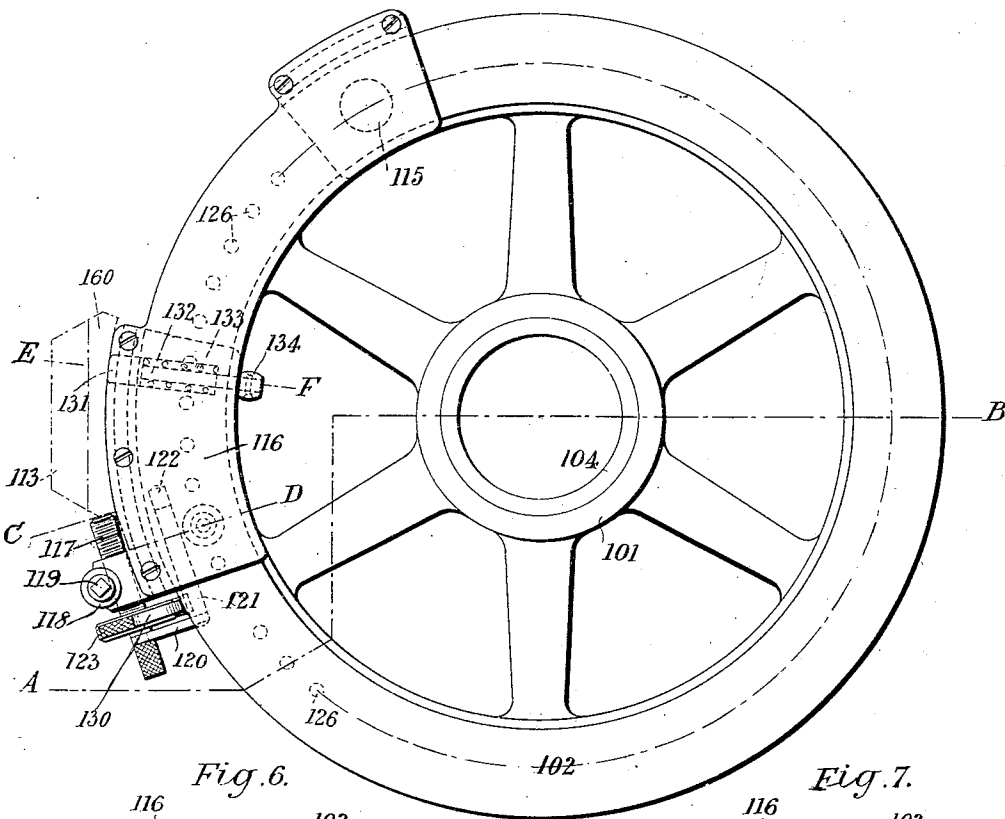

Fig. 6.

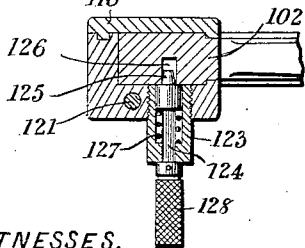
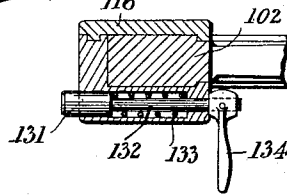

Fig. 7.



WITNESSES.  
*Lucius Warner*  
*A. S. Jesbera*

INVENTOR  
*Ernst Gustav Hoffmann*  
*by Redding, Kiddle, Greeley*  
*Attys*

# UNITED STATES PATENT OFFICE.

ERNST GUSTAV HOFFMANN, OF CHELMSFORD, ENGLAND.

## MACHINE FOR GRINDING BALLS.

SPECIFICATION forming part of Letters Patent No. 703,065, dated June 24, 1902.

Application filed April 4, 1901. Serial No. 54,258. (No model.)

*To all whom it may concern:*

Be it known that I, ERNST GUSTAV HOFFMANN, a subject of the German Emperor, residing at Chelmsford, in the county of Essex, England, have invented a certain new and useful Improvement in Machines for Grinding Balls, of which the following is a specification.

This invention relates to an improvement in machines for grinding balls after they have been produced by turning or in other ways, the object being to provide a machine which is efficient in its action and one that can readily be adjusted so as to reduce the balls very accurately to the required extent.

The invention is illustrated in the accompanying drawings, in which—

Figure 1 is a side elevation of the machine. Fig. 2 is a front elevation. Fig. 3 is for one half a side elevation and for the other half a central section, on an enlarged scale, to show the grinding, feeding, and discharging devices and connected parts. Fig. 4 is a plan, on an enlarged scale, of the mechanism for providing the adjustment whereby the amount the balls are reduced may be regulated. Fig. 5 is a section on line A B of Fig. 4. Fig. 6 is a section on line C D of Fig. 4. Fig. 7 is a section on line E F of Fig. 4.

According to my invention all the principal parts of the machine are arranged around or carried by a central fixed spindle 1, by which many advantages in alinement and rigidity may be obtained. This spindle is suitably held in the base portion 2 of a frame 3, in which is supported so as to be capable of rotation the driving-shaft 4, driven from a pulley 5. Carried by the fixed spindle is a stationary feather-edged holding support or ring 6, Fig. 3, for the balls 7, the carrying means consisting of a disk 8, having a hub which is held to the spindle by a wedge 9 and nut 10 on a screwed portion of the spindle.

Passing through the disk 8 are a series of bolts 11, carried by a radial-armed plate 12, between which and the disk 8 there is interposed on each bolt a spring 13. The plate 12 is vertically movable on the spindle and supports a slidable sleeve 14, forming part of a four-point ball-bearing adjustable by a locking-nut 15 in a chamber of a casing 16, which has formed with it or carries a pulley 17 for

a belt 18 and has also a further chambered portion 19 for a ball-bearing, the sleeve portion 20 of which is also vertically movable on the spindle. The bearing is adjustable by a lock-nut 21, and both sleeves 20 and 14 are prevented from turning by pins 22, which can move in a groove 23 in the spindle. The cover 16 carries an emery, carborundum, or other suitable grinding-ring 24, held therein by a wedge-shaped ring 25, which is forced into a correspondingly-shaped recess in the cover by a nut 26, screwed upon the outside of same, the feeding of the grinding-ring to compensate for wear being obtained by a nut 27. Surrounding the ring 26 and abutting against same and a lower ring 28 is an exhaust-casing 29 in communication with a pipe 30, Fig. 1, connected to an exhaustor or other suitable device, said casing being provided with a slide 31, capable of moving on suitable ways in which is a rack 32, secured to the frame 3, the slide 31 carrying a pinion 33, engaging with the rack and capable of operation by worm-gearing 34 from a hand-wheel 35. The ring 28 has a sloping table-surface 36 and is carried by a ring 37, which also carries a ball supporting and driving ring 38. The ring 37 has a truncated conical lower portion having a seat or surface 39, forming part of a sphere and bearing on a truncated conical part of a ring 41, having a plane surface 40.

The ring 37 carries a pin or pins 42, which project into slots 43 in the ring 41, and the latter has inside same a threaded portion with which a threaded nut 44 engages, such ring having a flange 45, adapted to project over the lower end of the ring 37, and also having a screwed pin or pins 46 projecting therethrough and bearing on the ring 41. The ring 41 has a sleeve 47, chambered to contain two sets of ball-bearings working on slidable sleeves 48 49 on the spindle 1, such sleeve having pins 50 50, engaging with a groove 51 on the spindle, by which their rotation is prevented, while the bearings are adjustable by locking-nuts 52 52. Secured to the sleeve 47 is a pulley 53, operated by a belt 54. The sleeve 47 and its connected parts are supported through one of the locking-nuts 52 on a suitable thrust-bearing 56, preferably of the ball type, as shown, which is slidable on the spindle and is in turn supported by a

collar 57, upwardly pressed by a spring 58, which seats in a box 59, supported by the boss 60 of an arm 61.

The box 59 is inclosed as to its upper part 5 by a cover 62, which is screwed thereto and can after adjustment be securely held by a lock-nut 63. The arm 61 has a slide 64, capable of moving on ways over the fixed rack 32 and containing a pinion 65, which engages 10 with the rack and can be operated by a hand-wheel 66.

Surrounding the ring 28 is an annular trough 67, having an annular opening 68, through which the table portion 36 of the ring 15 28 may pass, and such trough is provided with a discharge-spout 69. Around the trough 67 is an annular hopper 70 for the rough balls to be ground, said hopper being supported through a ball-bearing 71 on an arm 72, having a slide 20 73, surrounding and capable of sliding on the same ways as the other slides and over the fixed rack 32, the slide carrying a pinion 74, engaging with the rack and capable of operation by worm-gearing 75 from a hand-wheel 25 76. The arm also carries a small hopper 77, situated under the discharge-spout 69 and which is capable of holding one charge of balls after having been ground, so that they are convenient for examination.

Between the hopper 70 and a wall 78 of trough 67 is a feed-ring 79, having slots 80 at the lower part, which are adapted at times to correspond with slots 81 in the wall 78 and at times to be brought by the movement of the ring opposite solid portions of such wall. 35 Fixed in the bottom of the hopper 70 are a series of pins 82, which at times are adapted to cover the slots 80 on the hopper side and at times to disclose some.

By a small rotative movement given to the feed-ring 79 the slots 80, which are each capable of containing a ball, will be disclosed to the hopper 70, and a ball will enter such slots past the pins 82 and will rest against the solid 45 portions of the wall 78, which is normally opposite a passage between two pins. A reverse movement of the ring 78 will bring the ball opposite one of the slots 81, so that it may escape therethrough onto a sloping table 50 portion 83, forming part of the hopper 70. The trough 67 and ring 79 being supported and carried by the hopper portion 70, which is in turn supported on the ball-bearing 71, the whole can be rotated or shaken easily to 55 cause the balls to pass readily from the hopper into the slots in the feed-ring and from thence out for the purpose of turning the hopper to readily fill it.

The driving-shaft 4 carries a pulley 85, 60 which is engaged with the shaft through a suitable clutch 86, such pulley driving, through the belt 54, the pulley 53. The clutch 86 is put into and out of action by a lever 87, pivoted at 88 to the slide 64 and provided with 65 lugs 89, adapted to embrace a pin 90 upon a lever 91, pivoted to the arm 61. The lever 91 has on its side a stop 92, having a wedge-

shaped under face, and the hand-wheel 66 carries on its inside face a pin 93, adapted to abut against the upper face of the stop when 70 the clutch is engaged with the pulley and the grinding is proceeding, as in the position shown in Fig. 1, the object being to prevent the hand-wheel being turned in the direction of the arrow, so as to lower the arm 61 when 75 the ball supporting and driving ring 38 is being rotated, as it will be seen that before the lever 91 can be moved to bring the stop 92 away from pin 93 the clutch-lever 87 must be raised to put the clutch out of operation, 80 which movement will release the pin 90. Hence during working the ball-holding parts cannot be lowered while they are rotating except as hereinafter described.

95 is a central bearing for the shaft 4, and 85 96 a pulley driving the belt 18, such pulley being operated through a suitable clutch 97, put in and out of action by a lever 98.

The frame 3 carries on an extension 99 of same an arm 100, the other end of which supports the upper end of the fixed spindle 1, 90 the latter for a short distance beneath which being threaded with a screw-thread of fine pitch. Upon this screwed portion is carried a nut 101, (see Figs. 5 and 6,) forming part 95 of a hand-wheel 102, said nut acting through a slidable sleeve 103 on the lock-nut 21 of the parts connected to the casing of the grinding-disk, so that by a turn or partial turn of the hand-wheel the casing can be forced down- 100 wardly. Inside the nut 101 is a supplementary nut 104, consisting of a ring screwed both on its outer and inner sides, the latter corresponding in its thread to the thread of the nut 101, such nut 104 being held in position 105 by a set-screw 105 and forming a means for taking up any slack between the nut 101 and its threaded spindle. The arm 100 carries a post 106, which supports by an arm 107 a dial-casing 108. This casing contains a suitable 110 spring mechanism acted upon by pressure from a rod 109, which passes down through the fixed spindle 1 and terminates in a star-piece 110, Fig. 3, the arms of which pass through slots 111 in such spindle and rest 115 upon the sleeve 48, so that as the latter, together with the ball supporting and driving ring 38, is moved up by the pressure of the spring 58 an indication of the size to which the balls are being gradually reduced is shown 120 on such dial.

The arm 100 has a split extension 112, carrying a feather-edged slide 113, Fig. 4, said slide being adjustable vertically by a clamping-screw 114, which can grip the split portion of the extension-arm upon the slide. 125

The hand-wheel 102 carries a suitable handle 115 for operating it conveniently. It further carries a slide 116, provided with a screw 117, forming a stop, the end of which is adapted 130 to abut against a block 160, carried by the lower edge of the slide 113. Such screw 117 passes through a split clamping part 118 of the slide, which is adapted to be tightened

thereon by a screw 119, and it also carries an arm 120, having a guide-pin 121, passing into a hole 122 in the slide, and a head 123, a complete rotation of which is adapted to retract the screw, so that the hand-wheel 102 can be moved to an extent which will lower the grinding-ring sufficiently to remove, say, one ten-thousandth of an inch from the balls. The head 123 is notched on its periphery, so that it may be held in position by a spring 130, (see Fig. 5,) which is carried by the pin 121, so that it moves with the screw. On its under side the slide carries a spring-box 123, in which is an indexing-pin 124, having a tapered point 125, adapted to engage with holes 126 on the under side of the hand-wheel 102, the rod being forced upwardly for this purpose by a spring 127.

The indexing-pin has a knurled head 128 for the purpose of operating it. The holes 126 may be placed such a distance apart that they may correspond to one one-thousandth of an inch reduction on the diameter of the balls, such pin being a convenient method of securing the slide in position on the wheel within these limits, the fine adjustment being obtained by the screw 117. The slide also carries a stop 131, acting also as a frictional holding device, having a reduced part 132, passing through a hole in the slide and normally projected forward by a spring 133 in such hole, but capable of being withdrawn by a trigger 134. This rod 131 is adapted to abut against the block 160 of the slide 113 and forms a preliminary stop or rough adjustment which is useful when first moving the hand-wheel, as such rod 131 by coming in contact with the block will prevent the wheel being turned farther, so that danger of bringing the continuously-rotating winding-ring into premature contact with the balls is prevented. As soon as this stop strikes the block 160 it is withdrawn by its trigger, and its end will then make frictional contact with the side of this block 160 as the wheel is pushed farther around to bring the screw 117 into contact with such block. This frictional contact steadies the wheel and prevents any movement of same during adjustment.

The operation of the apparatus is as follows: To fill the ball supporting and driving ring 38, the hand-wheel 66 is rotated, (after first throwing the clutch 86 out of action, as described,) so as to lower the arm 61, pulleys 53, rings 41, 44, and 37, ball-ring 38, and table 36, so as to bring the latter onto a level with the lower edge of the surface 83. The ring 79 in the ball-hopper is now moved to allow the requisite number of balls to run from the hopper into the groove 38<sup>a</sup> of the ring 38, and the reverse movement of the parts is effected, so as to bring the ring 38, with the balls, against the holding-ring 6 and grinding-ring 24. The clutch 86 being put into action, the ball-holding ring is rotated, its action, together with that of the holding edge of the ring 6, being to turn the balls over and over as they are rotated,

so their entire surface is brought against the edge 24<sup>a</sup> of the grinding-ring. This is effected by the sides of the groove 38<sup>a</sup>, which are inclined to about ninety degrees to each other, acting in conjunction with the edge of the ring 6, which is preferably situated off the center line of the meeting-points of the angle-faces forming the groove in the ring 38. The grinding-ring 24 and casing 16 are rotated from the pulley 96 at a higher speed than the ring 38 and in the opposite direction, the clutch 97 being thrown into action for the purpose, and the grinding proceeds, the spring 58 raising the ring 38 as required by the reduction given to the balls until through the rod 109, which is forced up with these parts, the amount of reduction required is shown upon the dial. The amount of reduction is regulated beforehand by the movement of micrometer hand-wheel 102, as stated, the pressure of which acts through the radial-armed plate 12 upon the springs 13, the latter serving to counteract the effects of gravity of the grinding-wheel and its connected parts. It is obvious that this spring or springs act as a counterpoise for the grinding-ring and that a weight could be substituted therefor. The products of the grinding are drawn off through the exhaust-casing 29, which may be raised or lowered out of the way by the hand-wheel 35 when it is desired to inspect the parts covered by same, the pipe 30 being telescopic, so that the casing may have the necessary vertical movement. To empty the ring 38, its rotation is stopped through the clutch 86, and it is lowered with its connected parts by means of the hand-wheel 66 until the table 36 is in the annular opening 68 of the trough 67, when the clutch is put into operation for a moment, with the result that the balls are thrown outwardly into the trough 67, which is inclined in the direction of the discharge-pipe 69, down which the balls then pass. By reason of the spherical seat 39 bearing on the plane 40 a slight rocking movement is allowed to the ring 38, so that it may adjust itself to inequalities of the balls or of other parts.

When it is desired to regrind the angled groove in the ring 38, the nut 44 is rotated so that its flange 45 grips the lower end of the ring 37 and holds it tightly on the plane 40, so that it cannot rock, the screwed pins 46 being employed to keep the nut 44 out of action while grinding. For the purposes of this regrinding the hopper 70 and connected parts are lowered by means of the hand-wheel 76, so that a suitable grinding device carried by a rest or otherwise can be introduced to act on the groove 38<sup>a</sup> in the ring 38, the latter being lowered for this purpose. As the grinding-ring wears away it is lowered by the nut 27 after loosening the nut 26 and wedge-ring 25. The stationary ring 6 is likewise re-ground after wear in position by rotating it upon the shaft 1, the wedge 9 being loosened for the purpose and acting then as a tapered bearing, while the ring is driven by connect-

ing it with any suitable part rotated from the pulley 53.

What I claim is—

1. In a ball-grinding machine, the combination with a grinding device, of a ball-supporting ring, a holding device for the balls, acting in conjunction with the ball-supporting ring and a common fixed spindle for carrying all of said members. 5
2. In a ball-grinding machine, the combination with a central fixed spindle, of a grinding-ring, means for vertically adjusting same, a casing whereby said ring is carried, means for rotating said casing and ring, a holding-down ring for the balls, means for securing it to the spindle a counterpoise for the grinding-ring against which the pressure of the grinding-ring is exerted, and means for holding the balls up to the grinding medium. 10 15
3. In a ball-grinding machine the combination with a grinding-ring of a revoluble ball-supporting ring and means for allowing same a rocking movement to adjust itself to inequalities of the balls. 20
4. In a ball-grinding machine the combination with a grinding-ring of a revoluble ball-supporting ring, means for allowing same a rocking movement to adjust itself to inequalities of the balls, and means for locking such rocking means so that the revoluble ball-supporting ring may be firmly held while being rotated for regrinding purposes. 25 30
5. In a ball-grinding machine, and in combination, a central spindle, a grinding-ring, means for rotating the latter, a ball-supporting ring having an angular groove for the balls, a part carrying such ball-ring, a spherical seat on such part, a plane portion carrying such spherical seat, means for connecting the two surfaces so that they may be rotated together while capable of a rocking movement, and means for carrying and rotating the inclined plane portion. 35 40
6. The combination with a grinding-ring, and a ball-supporting ring, and means for rotating both, of an annular ball-holding hopper, a ball-holding trough and discharging means carried by same, and means carried by the hopper whereby the balls can pass therefrom in regulated numbers to the ball-supporting ring. 45 50
7. The combination with a ball-supporting ring and grinding and holding devices for the balls, of means for rotating such ring, means for raising and lowering same, and a trough surrounding such ring for receiving the balls thrown out by the rotation of the ring. 55
8. The combination with a ball-supporting ring and grinding and holding devices for the

balls of means for raising and lowering such ring, a hopper surrounding such ring, and means carried by the hopper whereby a regulated number of balls can be released to fill the ring. 60

9. In a ball-grinding machine, the combination with a revoluble grinding-ring, a revoluble ball-supporting ring, and a fixed holding-ring of an annular ball-holding hopper, means for feeding the balls from same, means for receiving the balls from the ball-supporting ring when discharged therefrom and means for raising and lowering such ring. 65 70

10. In a ball-grinding machine, the combination with a central fixed spindle having a threaded portion, of a grinding-ring, a casing whereby said ring is carried, means for rotating said casing and ring, means for holding the balls up to the grinding-ring, a nut carried by the threaded portion of the spindle, a hand-wheel for rotating same, a slide, means for carrying same, and an adjustable stop carried by the hand-wheel and acting in conjunction with the slide, whereby the amount of rotation of such hand-wheel can be regulated. 75 80 85

11. In a ball-grinding machine, the combination with a central spindle, a ball-grinding ring, means for rotating same, a ball-supporting ring, means for rotating same, a spring for forcing same upwardly so as to maintain the balls in contact with the grinding-ring, and means for indicating the decreasing diameter of the balls during grinding. 85 90 95

12. The combination with a ball-supporting ring and means for imparting a vertical movement to same, of a grinding device, a spindle carrying such ball-supporting ring, a dial and means carried by the spindle and controlled by the vertical movement of the ball-supporting ring whereby the amount of such movement is directly indicated. 95 100

13. The combination with a ball-supporting ring and means for rotating same comprising in its parts a clutch device, of a slide by which such ring is carried, means for moving such slide vertically, and means carried by such slide and capable of interlocking with a part of the clutch device whereby such clutch must be thrown out of action before the slide is moved vertically. 105 110

In testimony whereof I have hereunto set my hand in the presence of two subscribing witnesses.

ERNST GUSTAV HOFFMANN.

Witnesses:

EDWARD TRUMP FOSTER,  
ALLEN PARRY IRNE.