



US 20080081744A1

(19) **United States**

(12) **Patent Application Publication**
Gormley

(10) **Pub. No.: US 2008/0081744 A1**

(43) **Pub. Date: Apr. 3, 2008**

(54) **ADJUSTABLE PLATE LOADED
KETTLEBELL**

Publication Classification

(76) Inventor: **Joseph E. Gormley**, Rockford, IL
(US)

(51) **Int. Cl.**
A63B 21/075 (2006.01)

(52) **U.S. Cl.** **482/93**

Correspondence Address:
**ANDRUS, SCEALES, STARKE & SAWALL,
LLP**
100 EAST WISCONSIN AVENUE, SUITE 1100
MILWAUKEE, WI 53202

(57) **ABSTRACT**

An adjustable kettlebell has a series of plates in stacked relationship, a handle having a shaft passing through the weights and a retaining arrangement including a base plate engageable with the shaft for holding the plates together between the handle and the retaining arrangement. The invention is improved by a dome top having an outer surface formed with a locating pocket for receiving a portion of the handle in a snap fit therein, and an inner surface positioned upon an uppermost surface of the plates, and a reinforcement plate snap fit into a central hub of the base plate and engageable with a lower end of the shaft.

(21) Appl. No.: **11/861,734**

(22) Filed: **Sep. 26, 2007**

Related U.S. Application Data

(60) Provisional application No. 60/847,692, filed on Sep. 28, 2006.

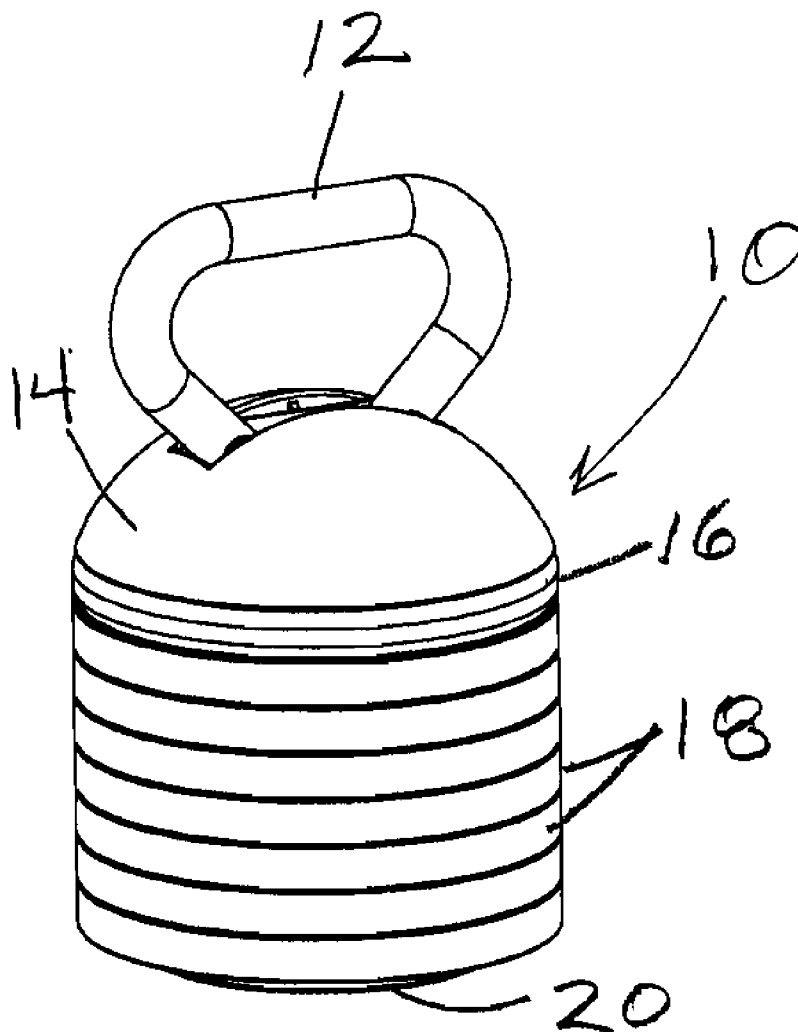

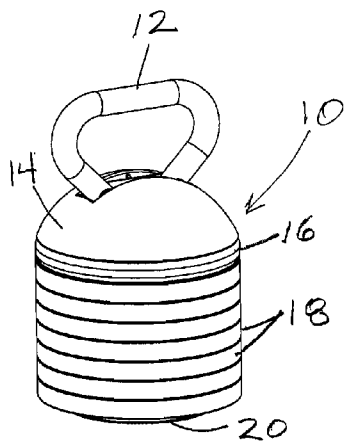

FIG. 1

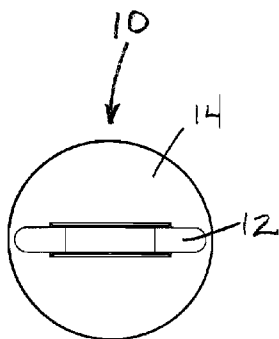

FIG. 2

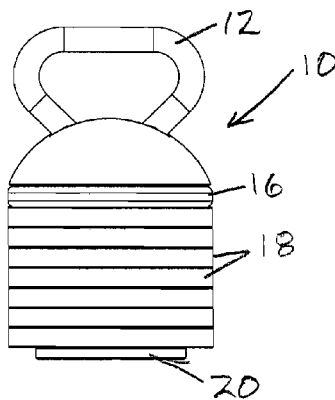

FIG. 3

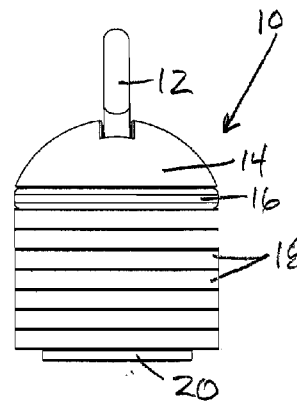

FIG. 4

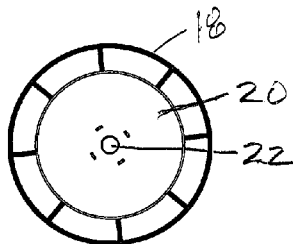

FIG. 5

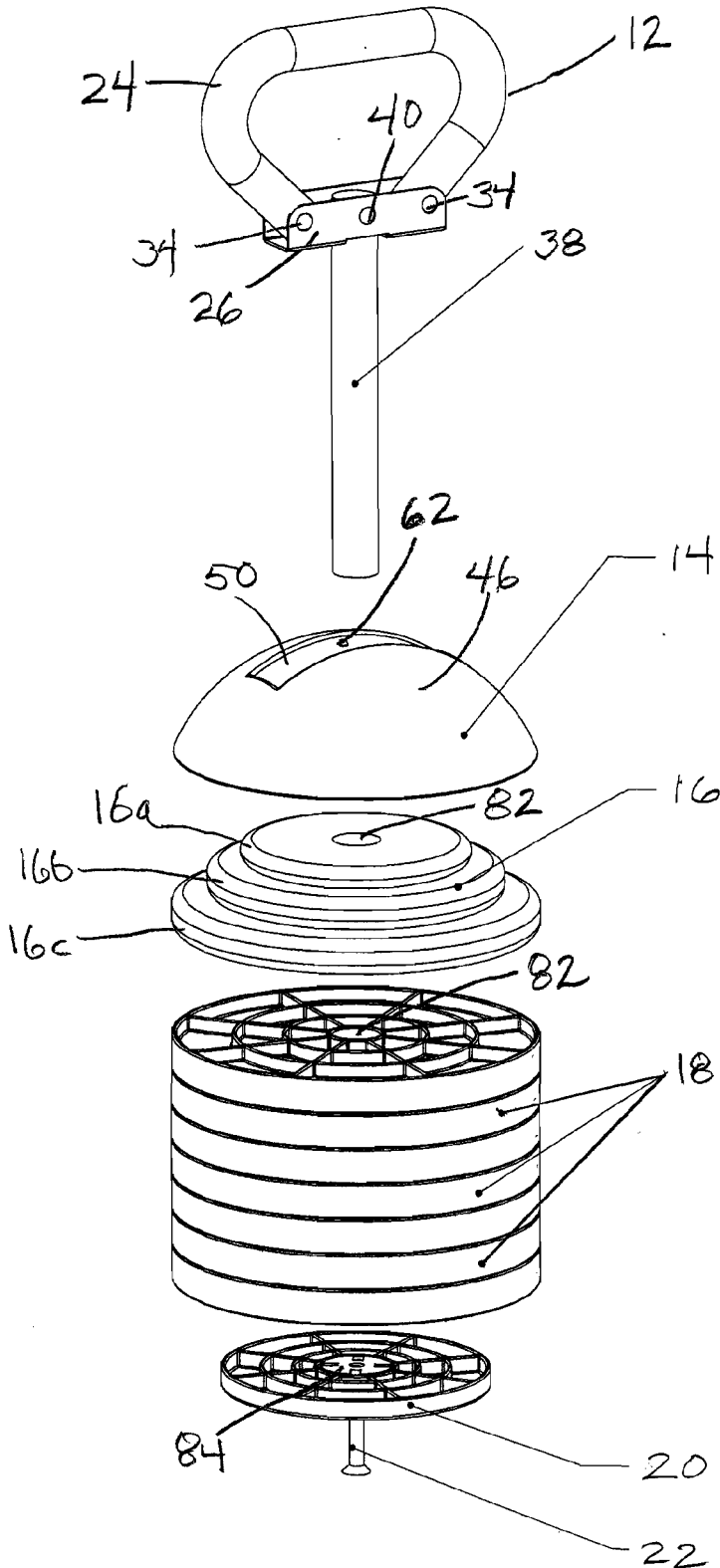

FIG. 6

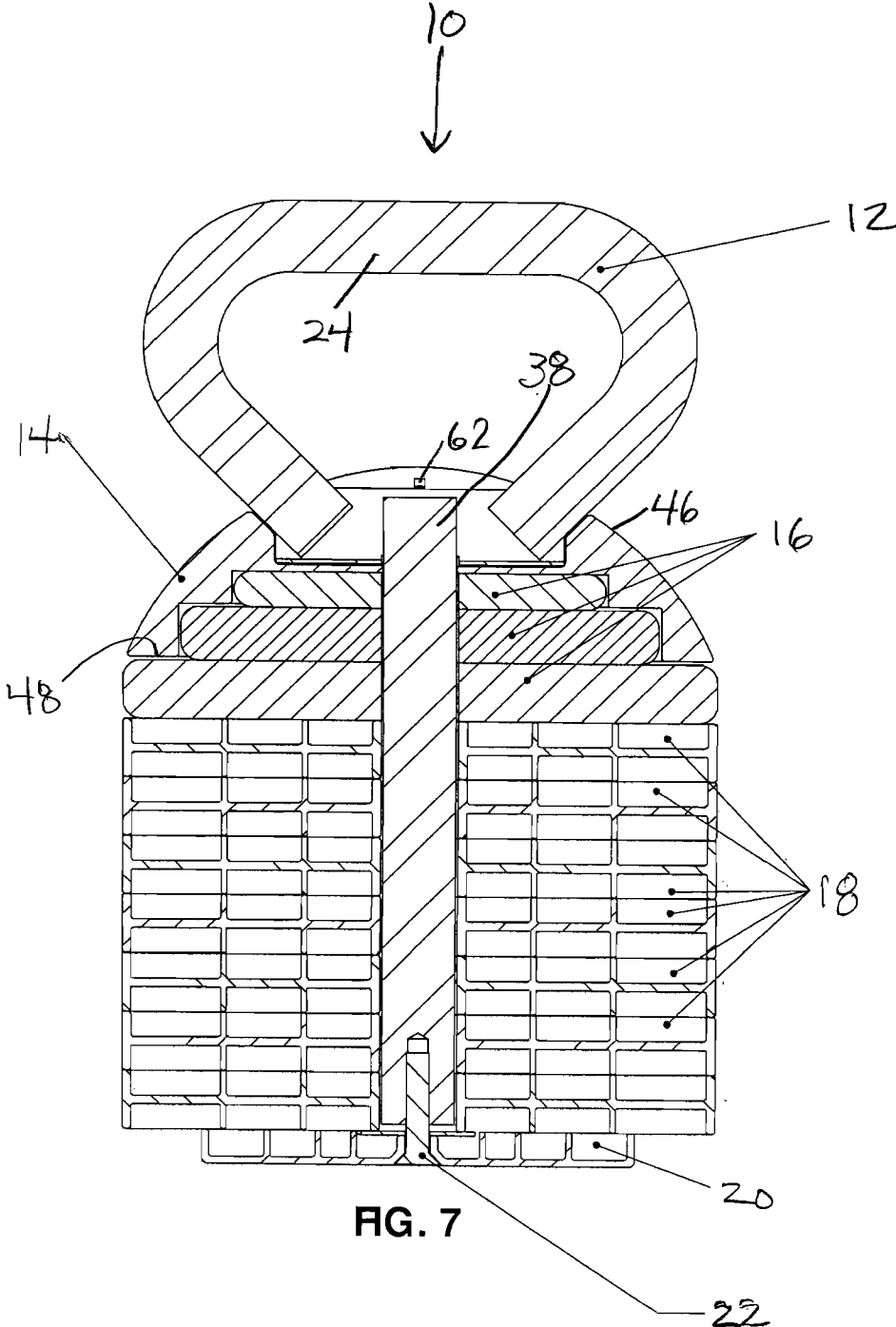

FIG. 7

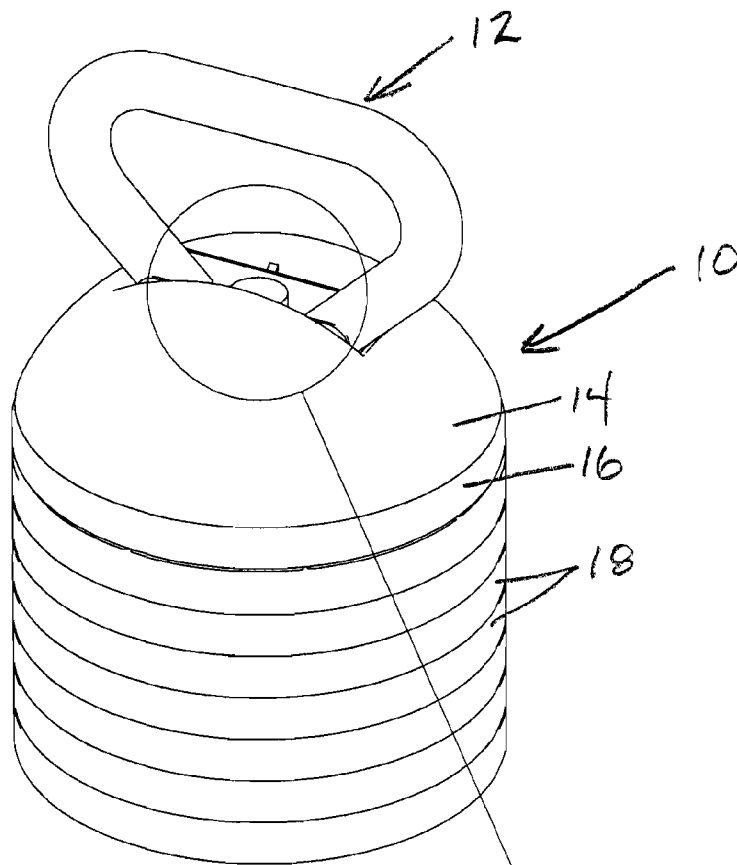

FIG. 8

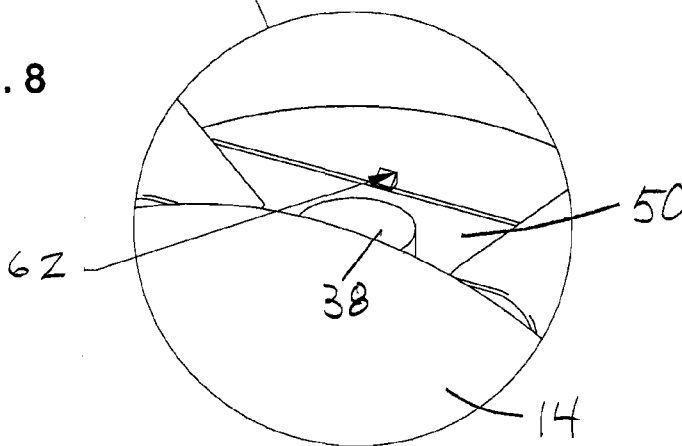

FIG. 9

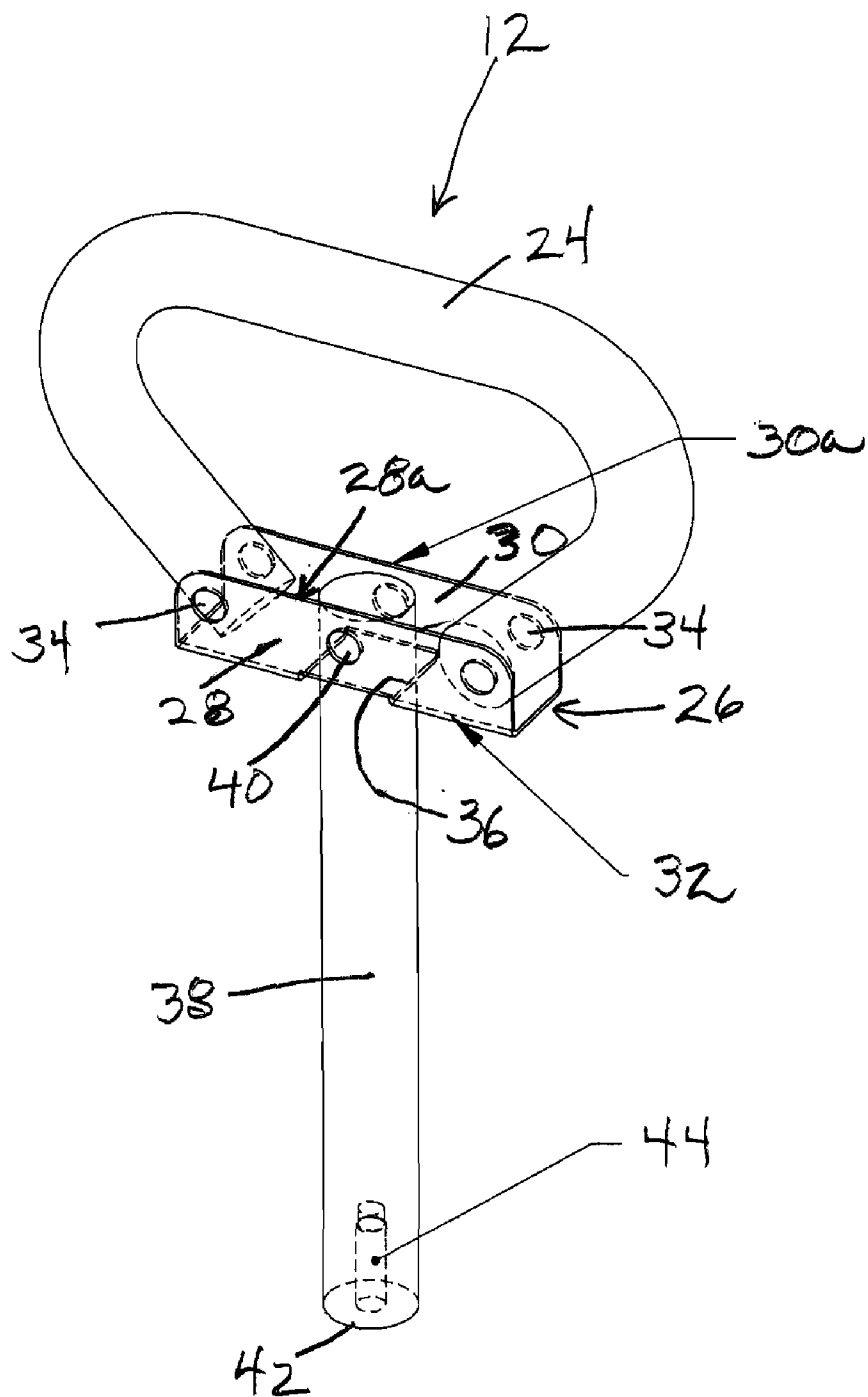

FIG. 10

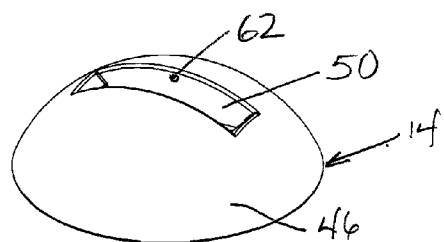

FIG. 11

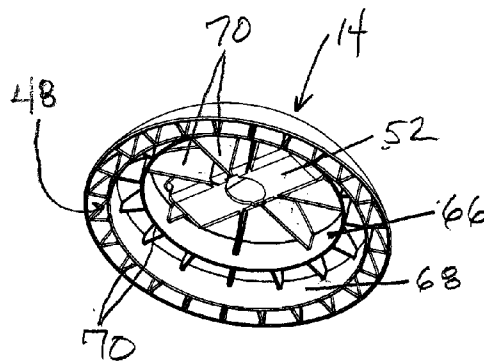

FIG. 12

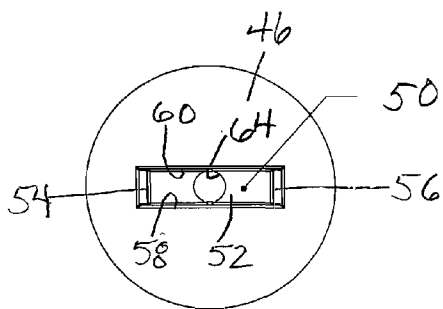

FIG. 13

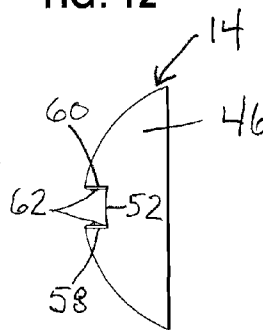

FIG. 14

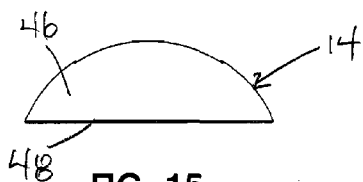

FIG. 15

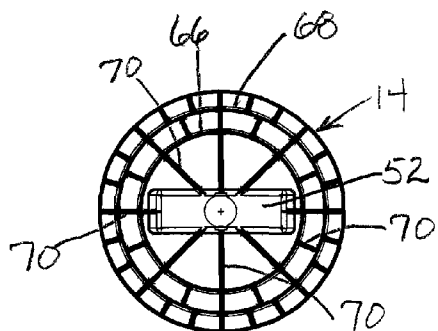

FIG. 16

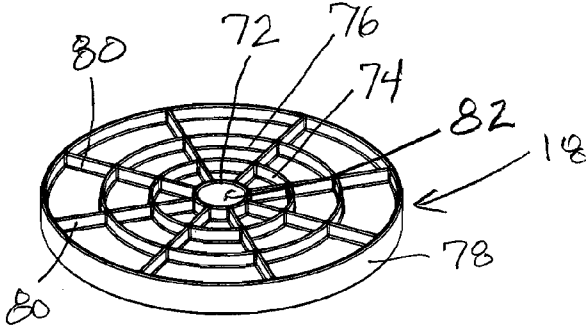

FIG. 17

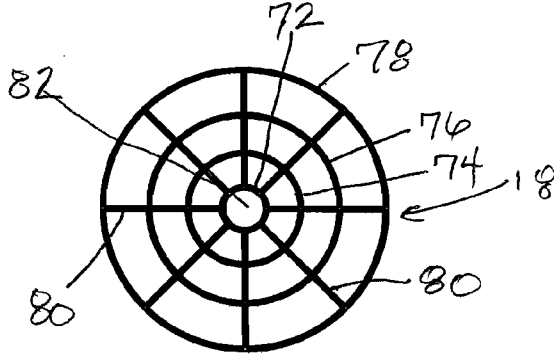

FIG. 18

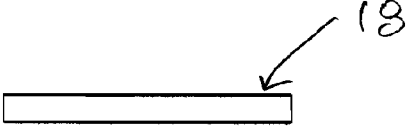

FIG. 19

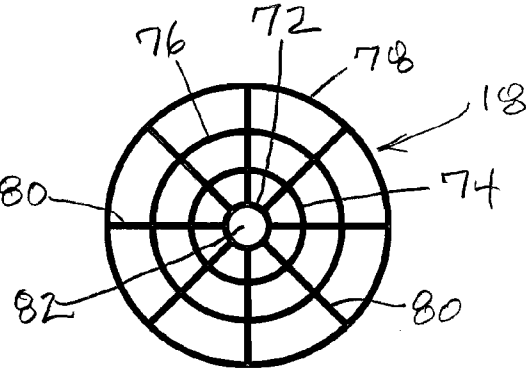
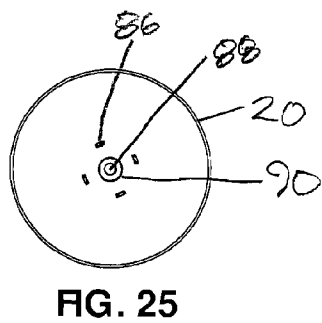
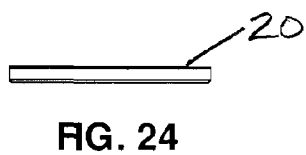
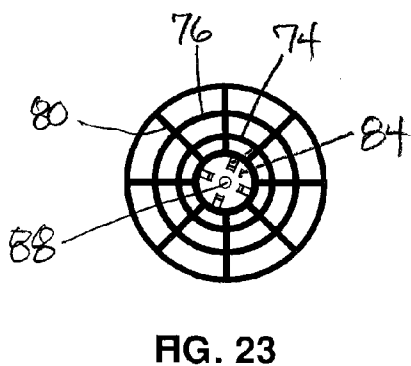
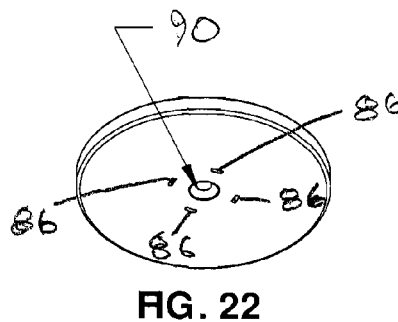
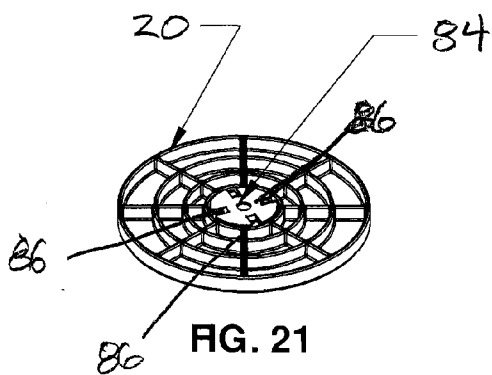

FIG. 20



ADJUSTABLE PLATE LOADED KETTLEBELL

CROSS REFERENCE TO RELATED APPLICATIONS

[0001] This application relates to and claims priority from U.S. Provisional Patent Application Ser. No. 60/847,692, filed Sep. 28, 2006.

FIELD OF THE INVENTION

[0002] The present invention relates generally to exercise training devices and, more particularly, pertains to an adjustable plate loaded kettlebell used to develop strength, endurance, work capacity and balance in physical conditioning of the human body.

BACKGROUND OF THE INVENTION

[0003] The kettlebell is an exercise device that has been in the United States and Europe for over a century. The typical traditional kettlebell is a non-adjustable, cast iron weight that looks like a cannon ball with a suitcase handle on its top. Cast iron kettlebells are expensive ranging and priced from \$90.00 for a 16 kilogram kettlebell and up to \$180.00 for a 40 kilogram kettlebell. There are also demands for a wider range of kettlebell weights, since they are only generally available in fixed weight versions of 16, 24, 32 and 40 kilograms. Several problems characterize the use of kettlebells. The athlete must have a wide range of kettlebells. As strength levels increase, the athlete needs a heavier kettlebell that can be increased in weight by small increments. In order to be able to increase the weights of smaller increments, the cast iron kettlebells would have to come in more sizes. Storage and expense would then become a problem.

[0004] One type of adjustable kettlebell is disclosed in U.S. Pat. No. 1,316,683, issued to Calvert on Sep. 23, 1919. In this design, a separate handle is screwed onto a separate shaft which passes through a series of stacked, non-rotatable weight plates enclosed by a pair of hemispherical casing portions. A nut is attached to the bottom of the shaft and acts as a depression in the lower portion of the casing to aid in holding the components of the device together.

[0005] In recent years, other versions of the kettlebell have appeared in which bar bell plates have been attached to a handle, these plate loaded kettlebells are adjustable from 10 lbs. to over 100 lbs. An example of recent adjustable plate loaded kettlebells is shown in U.S. Design Pat. Nos. D522,594 and D522,595, both of which issued Jun. 6, 2006 to Gregory J. Donahue and Joseph E. Gromley.

[0006] Despite the existence of the prior art, it remains desirable to provide an adjustable kettlebell with a unique handle and plate retaining structure.

SUMMARY OF THE INVENTION

[0007] It is a general object of this invention to provide a kettlebell than enables an athlete or exerciser to be able to have a kettlebell that can be increased in weight with small increments. Doing this will enable an athlete or exerciser to train more effectively while reducing the cost and storage space that would be necessary for a large set of cast kettlebells.

[0008] The present invention relates to an adjustable kettlebell including a first set of vertically stacked plates having central bores registered with each other and fully

exposed, outer peripheral edges aligned with each other. A retaining plate is positioned in stacked relationship against a lowermost one of the first set of plates and has a flat bottom, and a central reinforcement plate with a central hole aligned with the central bores of the plates. A dome top has an outer surface formed with a locating pocket therein, and an inner surface positioned upon an uppermost one of the first set of plates. The inner surface is recessed to receive a second set of vertically stacked plates having central bores registered with each other and with the central bores of the first set of plates. A handle unit is integrally formed by a rounded handle portion including lower ends joined to a handle base that has an internally threaded shaft depending therefrom. The handle base is snap fit in the locating pocket of the dome top, and the shaft passes through the central bores of the first and second set of plates and contacts the reinforcing plate at a lower end of the shaft. A fastener passes through the central hole in the reinforcement plate and is threaded into the lower end of the shaft for holding the first and second set of plates, the handle unit, the dome top and the retaining plate together.

[0009] The locating pocket is defined by a bottom wall, a pair of end walls and a pair of opposed side walls provided with retaining snaps thereon. The handle base includes a U-shaped channel having front and back walls joined to a lower wall. The handle base is received in the locating pocket such that upper edges of the front and back walls define snap edges that are engaged by the retaining snaps on the side walls of the locating pocket enabling the handle base to be frictionally retained in the locating pocket. The lower wall of the handle base engages the bottom wall of the locating pocket. The inner surface of the dome top includes a set of recesses of varying sizes for accommodating varying sizes of the second set of plates. Certain of the first set of plates are solid weight plates and others of the first set of plates are plastic spacer plates. Each plastic spacer plate has a circular hub, a first inner ring surrounding the hub, a second inner ring surrounding the first inner ring, an outer peripheral edge surrounding the second inner ring and a series of radially extending walls connecting the inner rings and the peripheral edge. The second set of plates are preferably solid weight plates. The retaining plate is a plastic plate having a central hub for receiving the reinforcement plate in a snap fit. The handle unit, the weight plates, the reinforcement plate and the fastener are all constructed of metal.

[0010] In another aspect of the invention, an adjustable kettlebell has a series of plates in stacked relationship, a handle having a shaft passing through the plates and a retaining arrangement including a base plate engageable with the shaft holding the plates together between the handle and the retaining arrangement. The invention is improved by a dome top having an outer surface formed with a locating pocket for receiving a portion of the handle in a snap fit therein, and a lower surface positioned upon an uppermost surface of the plates, and a reinforcement plate snap fit into a central hub of the base plate and engageable with the lower end of the shaft.

[0011] Various other objects, features and advantages of the invention will be made apparent from the following description taken together with the drawings.

BRIEF DESCRIPTION OF THE DRAWINGS

[0012] The drawings illustrate the best mode presently contemplated in carrying out the invention.

[0013] In the drawings:

[0014] FIG. 1 is a perspective view of an assembled, adjustable plate loaded kettlebell embodying the present invention;

[0015] FIG. 2 is a top view of FIG. 1;

[0016] FIG. 3 is a front view of FIG. 1;

[0017] FIG. 4 is a side view of FIG. 1;

[0018] FIG. 5 is a bottom view of FIG. 1;

[0019] FIG. 6 is an exploded view of FIG. 1;

[0020] FIG. 7 is a sectional view of FIG. 1;

[0021] FIGS. 8 and 9 are views showing details of retaining structure in a dome top of the kettlebell;

[0022] FIG. 10 is a perspective view of the handle unit used in the kettlebell;

[0023] FIG. 11 is a top perspective view of the dome top of the kettlebell;

[0024] FIG. 12 is a bottom perspective view of the dome top;

[0025] FIG. 13 is a top view of FIG. 11;

[0026] FIG. 14 is a side view of FIG. 11;

[0027] FIG. 15 is a front view of FIG. 11;

[0028] FIG. 16 is a bottom view of FIG. 15;

[0029] FIG. 17 is a top perspective view of a spacer plate used in the kettlebell;

[0030] FIG. 18 is a top view of FIG. 17;

[0031] FIG. 19 is a front view of FIG. 17;

[0032] FIG. 20 is a bottom view of FIG. 17;

[0033] FIG. 21 is a top perspective view of a retaining plate used in the kettlebell;

[0034] FIG. 22 is a bottom perspective view of the retaining plate;

[0035] FIG. 23 is a top view of FIG. 21;

[0036] FIG. 24 is a front view of FIG. 21; and, [FIG. 25 is a bottom view of FIG. 23.

DETAILED DESCRIPTION OF THE PREFERRED EMBODIMENT

[0037] Referring to the drawings, FIGS. 1-7 illustrate a preferred embodiment of an adjustable plate loaded kettlebell 10 embodying the present invention. With particular reference to FIGS. 6 and 7, the kettlebell 10 is generally comprised of a handle unit 12, a dome top 14, a series of vertically stacked circular weight plates 16, a series of vertically stacked circular spacer plates 18, a flat retaining or base plate 20 and a threaded fastening screw 22.

[0038] As best seen in FIGS. 6 and 10, the handle unit 12 includes a wide, thick rounded handle portion 24 capable of being grasped centrally with one hand of an exerciser, or alternatively, on each end thereof with both hands of the exerciser. Bottom ends of the handle portion 24 are attached to a handle base 26 in the form of a U-shaped channel having a front wall 28, a back wall 30 and a lower wall 32 joined together. Rivets 34 secure the bottom ends of the handle portion 24 between the front and back walls 28, 30. The lower wall 32 is formed with an opening 36 for receiving a top end of a cylindrical shaft 38 that extends downwardly. Rivets 40 anchor the top end of the shaft 38 to the front and back walls 28, 30 of handle base 26. As seen in FIG. 10, the lower portion of the round shaft 38 has a flat end 42 and an internally threaded passage 44.

[0039] Referring now to FIGS. 6-9 and 11-16, the dome top 14 has an outer surface 46 and an inner surface 48. The outer surface 46 has a semi-hemispherical shape and is formed with a locating pocket 50 that is configured to

receivingly receive the handle base 26. The locating pocket 50 is formed with a bottom wall 52, a pair of end walls 54, 56, and a pair of opposed side walls 58, 60, each of which is provided with a retaining snap 62 thereon along an upper portion thereof. Bottom wall 52 is formed with a through hole 64 for receiving the shaft 38 of the handle portion 24.

[0040] It is a distinctive feature of the invention that once the shaft 38 is passed through the through hole 64, the handle base 26 is frictionally retained in the locating pocket 50 of the dome top 14 as the respective upper edges 28a, 30a of the front wall 28 and back wall 30 are snap fit beneath the retaining snaps 62 as depicted in FIGS. 8 and 9.

[0041] The inner surface 48 of dome top 14 includes a set of recesses of varying sizes for accommodating various sizes of the weight plates 16. As seen in FIG. 12, the recesses are formed by circular rings 66, 68 of varying diameters. The rings 66, 68 are interconnected by a plurality of radially extending walls 70 which are also joined to end walls 54, 56 and side walls 58, 60 of the locating pocket 50.

[0042] The adjustable kettlebell 10 is provided with a series of weight plates 16 and spacer plates 18. In the preferred embodiment, there are three solid weight plates 16a, 16b, 16c of varying diameter and weight which typically are constructed of metal. There are also seven spacer plates 18 of equal size which are preferably formed from plastic. As seen in FIGS. 17-20, each spacer plate 18 is identical and includes a circular hub 72, a first inner ring 74, a second inner ring 76 and an outer peripheral edge 78. Radially extending walls 80 interconnect the hub 70 to the ring 74, 76 and the peripheral edge 78. The weight plates 16a, 16b, 16c and the spacer plates 18 all have central bores 82 which are aligned or registered with each other when the kettlebell 10 is assembled.

[0043] A first set of circular plates is formed by weight plate 16c and spacer plates 18 with each plate having generally the same diameter. A second set of circular plates is formed by the weight plates 16a and 16b that are positioned inside the dome top 14. It should be understood that the plates may be any combination of weight plates and spacer plates as desired. All plates have flat upper and lower surfaces.

[0044] Referring to FIGS. 21-25, the retaining plate 20 is a plastic circular plate similar in construction to the spacer plates 18, but smaller in diameter. The retainer plate 20 has a flat top wall and a flat bottom wall. Another feature of the invention resides in a metal reinforcement disc 84 that is snap fit upon tabs 86 provided on the central hub 87 of the retaining plate 20. The disk 84 is formed with a central hole 88 that is designed to be aligned with the central bores 82 of the plates 16 and 18. The bottom wall of disk 84 also includes a recess 90 aligned with the hole 88 for completely receiving the head of fastening screw 22.

[0045] For assembly, the handle unit 12 is snapped into the dome top 14, the desired weight plates 16 and spacer plates 18 are loaded onto the handle shaft 38 and retaining plate 20 is positioned under the lowermost spacer plate 18 by threading the fastener 22 into the threaded passage 44 of the shaft 38.

[0046] When fully assembled, the plates 16 and 18 are tightly held between the bottom wall 52 of the locating pocket 50 and the retaining plate 20. The flat end 42 of shaft 38 is drawn against the reinforcement disk 84 in the center of retaining plate 20. The reinforcement disk 84 will help to absorb the forces transmitted along the shaft 38. The head of

fastening screw 22 is flush with the bottom of the retaining plate 20 so that the kettlebell 10 sits upright on a flat support surface to make it easily accessible to the exerciser. The assembled kettlebell 10 presents an aesthetic, compact, contour with the peripheral edges of the dome top 14, the weight plate 16c and the spacer plates 18 in alignment with each other. The bottom wall of the locating pocket 50 provides a stop surface for the uppermost surface of the top weight plate 16a. The dome top 14 provides for pockets to hold smaller weight plates 16 other than those held outside the dome top 14. The handle unit 12 has a design which is shorter in length than previous devices, and the retaining plate 20 and fastening screw 22 are designed so that the plates 16, 18 will vibrate should the screw 22 become loosened.

[0047] Although not illustrated, it should be appreciated that the kettlebell 10 may be assembled without the dome top 14 in which the case lower wall 32 of the handle unit 12 directly contacts the uppermost weight plate 16. It should be further appreciated that other locking mechanisms, such as a locking collar, may be used on the lower end of shaft 38 in lieu of the retaining plate 20 and screw 22.

[0048] Various alternatives and embodiments are contemplated as being within the scope of the following claims particularly pointing out and distinctly claiming the subject matter regarded as the invention.

What is claimed is:

- 1. An adjustable kettlebell comprising:
 - a first set of vertically stacked plates having central bores registered with each other and fully exposed, outer peripheral edges aligned with each other;
 - a retaining plate positioned in stacked relationship against the lowermost one of the first set of plates and having a flat bottom and a central reinforcement plate with a central hole aligned with the central bores of the plates;
 - a dome top having an outer surface formed with a locating pocket therein, and an inner surface positioned upon an uppermost one of the first set of plates, the inner surface being recessed to receive a second set of vertically stacked plates having central bores registered with each other and with the central bores of the first set of plates;
 - a handle unit integrally formed by a rounded handle portion including lower ends joined to a handle base having an internally threaded shaft depending therefrom, the handle base being snap fit in the locating pocket of the dome top, and the shaft passing through the central bores of the first and second set of plates and contacting the reinforcement plate at a lower end of the shaft, and
 - a fastener passing through the central hole in the reinforcement plate and threaded into the lower end of the shaft for holding the first and second set of plates, the handle unit, the dome top and the retaining plate together.

2. The adjustable kettlebell of claim 1, wherein the locating pocket is defined by a bottom wall, a pair of end walls and a pair of opposed side walls provided with retaining snaps thereon.

3. The adjustable kettlebell of claim 2, wherein the handle base includes a U-shaped channel having front and back walls joined to a lower wall.

4. The adjustable kettlebell of claim 3, wherein the handle base is received in the locating pocket such that upper edges of the front and back wall define snap edges that are engaged by the retaining snaps on the side walls of the locating pocket enabling the handle base to be frictionally retained in the locating pocket.

5. The adjustable kettlebell of claim 4, wherein the lower wall of the handle base engages the bottom wall of the locating pocket.

6. The adjustable kettlebell of claim 1, wherein the inner surface of the dome top includes a set of recesses of varying sizes for accommodating various sizes of the second set of plates.

7. The adjustable kettlebell of claim 1, wherein certain of the first set of plates are solid weight plates and others of the first set of plates are plastic spacer plates.

8. The adjustable kettlebell of claim 7, wherein each plastic spacer plate has a circular hub, a first inner ring surrounding the hub, a second inner ring surrounding the first inner ring, an outer peripheral edge surrounding the second inner ring and a series of radially extending walls connecting the hub, the inner rings and the peripheral edge.

9. The adjustable kettlebell of claim 1, wherein the second set of plates are solid weight plates.

10. The adjustable kettlebell of claim 1, wherein the retaining plate is a plastic plate having a central hub for receiving the reinforcement plate in a snap fit.

11. The adjustable kettlebell of claim 1, wherein the handle unit, the weight plates, and the reinforcement plate and the fastener are all constructed of metal.

12. In an adjustable kettlebell having a series of plates in stacked relationship, a handle having a shaft passing through the plates and a retaining arrangement including a base plate engageable with the shaft for holding the plates together between the handle and the retaining arrangement, the improvement comprising:

- a dome top having an outer surface formed with a locating pocket for receiving a portion of the handle in a snap fit therein, and an inner surface positioned upon an uppermost surface of the plates, and
- a reinforcement plate snap fit into a central hub of the base plate and engageable with the lower end of the shaft.

* * * * *