

(No Model.)

3 Sheets—Sheet 1.

D. P. MILLS.
CIRCULAR KNITTING MACHINE.

No. 433,132.

Patented July 29, 1890.

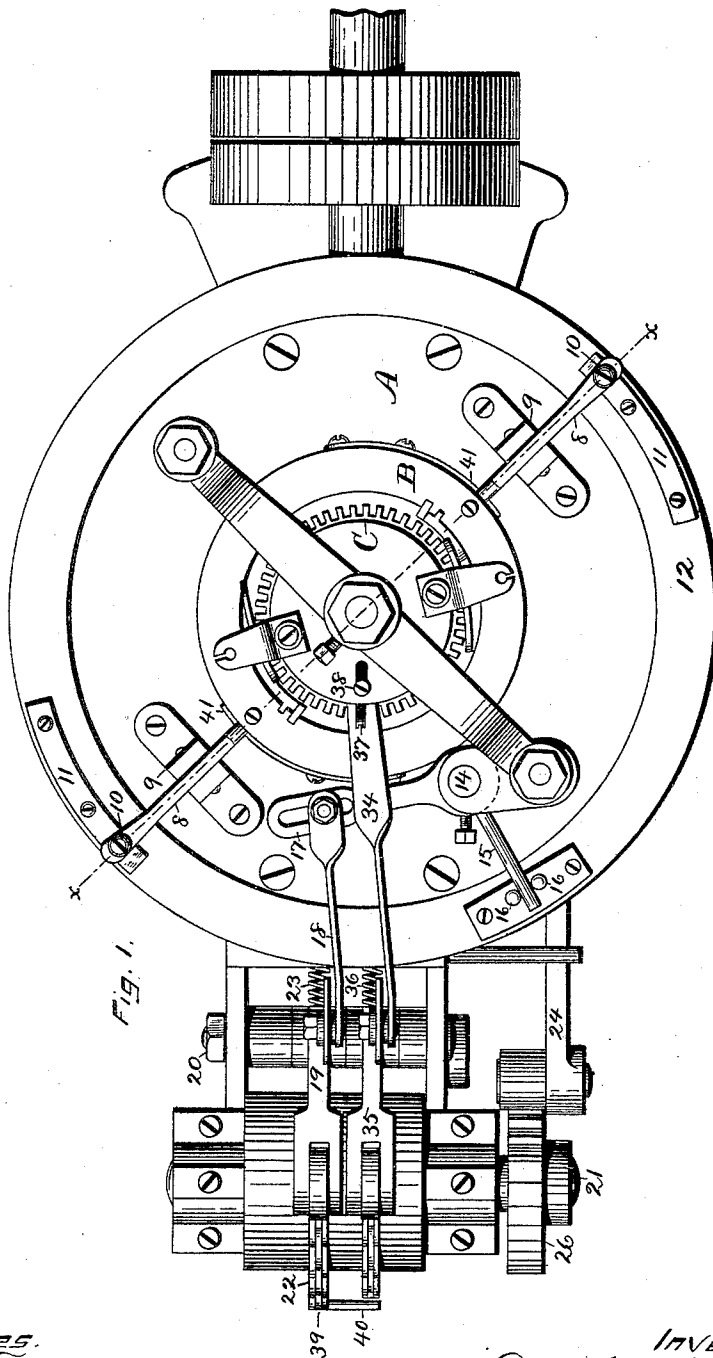

Fig. 1.

Witnesses.
John Edwards Jr.
Dr. B. Godding

Inventor.
Dwight P. Mills
By James Shepard Atty.

(No Model.)

3 Sheets—Sheet 2.

D. P. MILLS.
CIRCULAR KNITTING MACHINE.

No. 433,132.

Patented July 29, 1890.

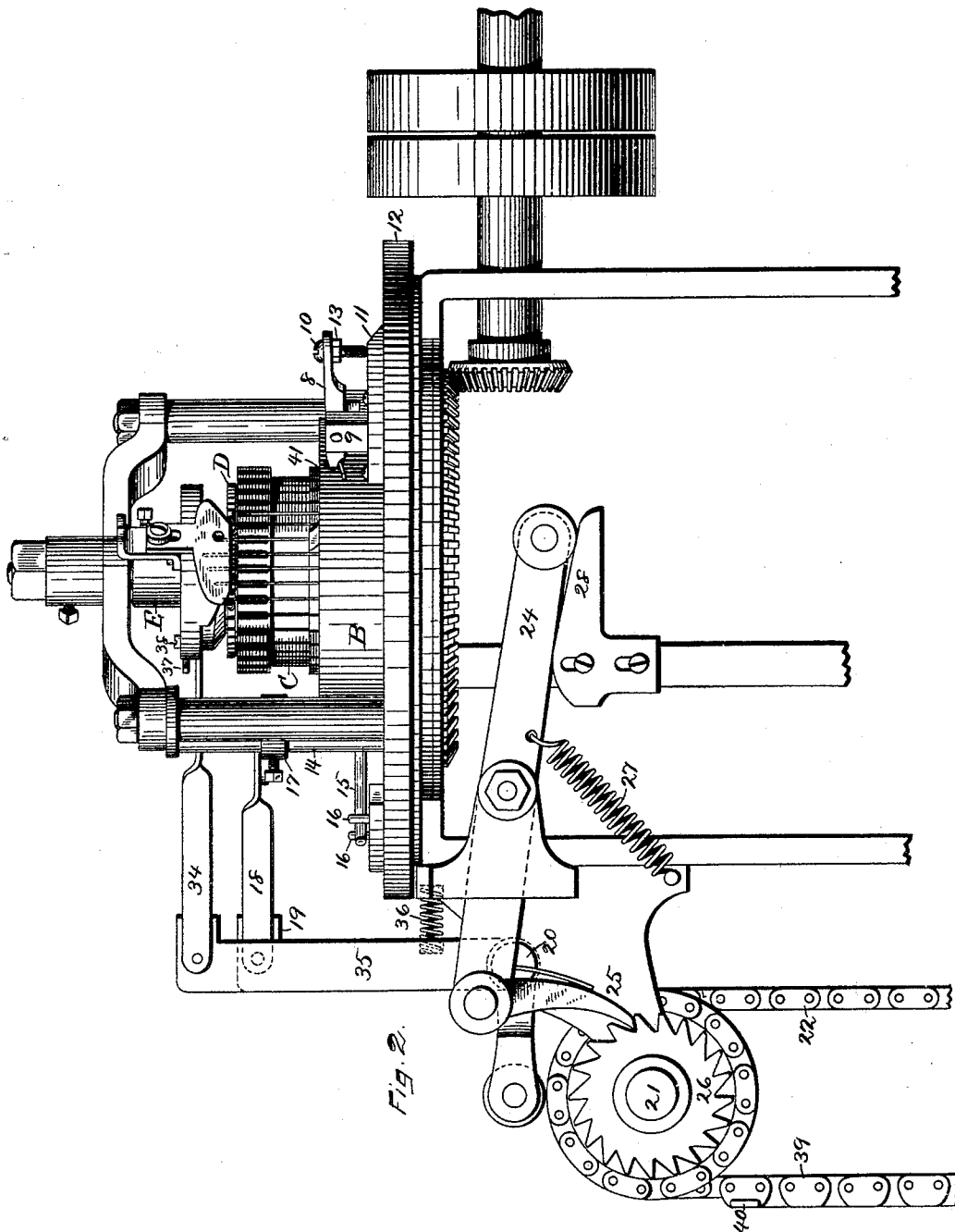

FIG. 2.

Witnesses.
John Edwards Jr.
Dr. B. Godding

Inventor.
Dwight P. Mills.
By James Shepard

Att'y.

(No Model.)

3 Sheets—Sheet 3.

D. P. MILLS.
CIRCULAR KNITTING MACHINE.

No. 433,132.

Patented July 29, 1890.

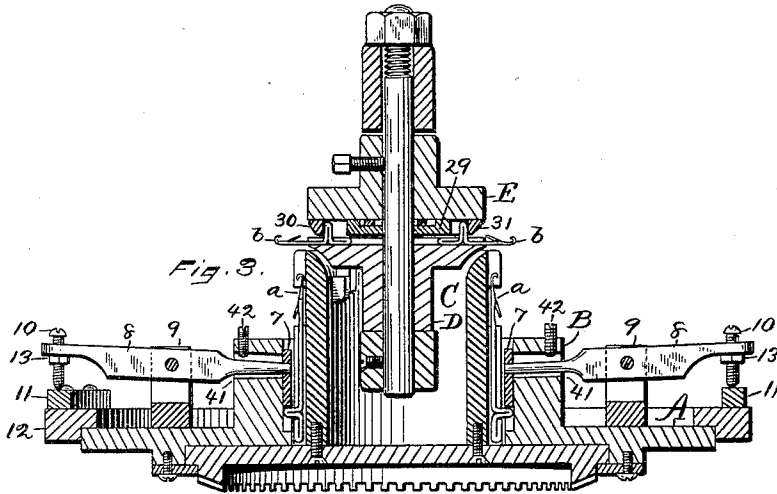

Fig. 4.

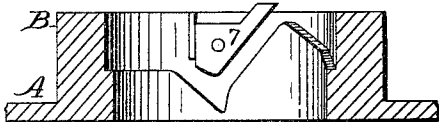

Fig. 5.

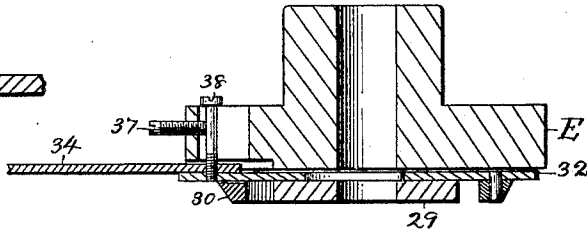
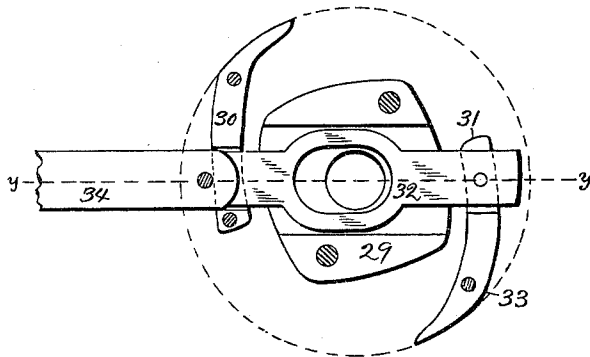

Fig. 6.



Witnesses.

John Edwards, Jr.
W. B. Godding

Inventor.

Dwight P. Mills.
By James Shepard

Att'y.

UNITED STATES PATENT OFFICE.

DWIGHT P. MILLS, OF NAUGATUCK, CONNECTICUT.

CIRCULAR-KNITTING MACHINE.

SPECIFICATION forming part of Letters Patent No. 433,132, dated July 29, 1890.

Application filed February 28, 1889. Serial No. 301,576. (No model.)

To all whom it may concern:

Be it known that I, DWIGHT P. MILLS, a citizen of the United States, residing at Naugatuck, in the county of New Haven and State of Connecticut, have invented certain new and useful Improvements in Circular-Knitting Machines, of which the following is a specification.

My invention relates to improvements in circular-knitting machines; and the objects of my invention are to provide a new and efficient means for automatically changing the length of the loops or stitches in various sections of the fabric, and also to provide means for knitting a dividing line or mark between such sections.

In the accompanying drawings, Figure 1 is a plan view of my knitting-machine. Fig. 2 is a side elevation of the main portions thereof. Fig. 3 is a vertical section of the main portions on the line *x x* of Fig. 1. Fig. 4 is a vertical section of the cam-cylinder, the plane of section being at right angles to the line *x x* of Fig. 1. Fig. 5 is a vertical section of the cam-plate and cams for the horizontal needles, the plane of section being indicated by the line *y y* of Fig. 6, and Fig. 6 is a horizontal section thereof on a line just above the slide and cams, the periphery of the cam-plate being indicated by the broken circle.

The machine which I have selected to illustrate my improvements is one which has a series of vertical needles operated in a needle-cylinder in connection with a series of radially-moving horizontal needles for producing a ribbed fabric, which machines are well known and do not require a detail description. The needles are not illustrated in Fig. 1, and only a portion of them are indicated in Fig. 2.

A designates the bed of the machine, upon which the cam-cylinder B is formed or mounted, within which cam-cylinder the needle-cylinder C and vertical needles *a* are mounted, said cylinder carrying with it the head D, Fig. 3, for revolving the horizontal needles *b*, all in the ordinary manner. The cam 7, Figs. 3 and 4, of the cam-cylinder which depresses the vertical needles, is adjustable up and down, and is acted upon by the inner ends of the levers 8, which inner ends engage said cams by entering holes

therein. These levers are pivoted to stationary studs 9 upon the bed A, which pivots serve as their fulera. The outer ends of these levers are provided with adjusting-screws 10, passing through said levers with their lower ends in position to engage the cams 11 on the cam-ring 12. Each cam has an incline or bevel at its nose or forward end for engaging the ends of said screws and raising those ends of the levers 8, which incline is followed by a flat supporting-face on which the ends of said screws rest when fully elevated, as shown most clearly at the right in Fig. 2. I prefer to provide each of said screws with a set-nut 13, to secure them in their adjusted position. The cam-ring is also provided with the adjusting-screws 42, which act as stops to limit the upward movement of the cams 7. This cam-ring is rabbeted at its inner edge, so that it rests upon and is centered by the circular outer edge of the bed A, as shown in Fig. 3.

Mounted on the framing in rigid bearings is a vertical rock-shaft 14, carrying a rigid arm 15, which lies in a recess in the cam-ring, of any proper form—as, for instance, that formed by the vertically-projecting pins 16 on said cam-ring—whereby a rocking motion of the shaft 14 will give a partial revolution to the cam-ring 12, so as to throw its cams under or out from under the ends of the adjusting-screws 10 of the cam-operating levers 8. The rock-shaft 14 is also provided with an arm 17, whose outer end is connected, preferably, by a bolt-and-slot connection with the link or pitman 18, the opposite end of said pitman being connected to the upper arm of the angle-lever 19, which lever is pivoted to the frame of the machine, as at 20, Figs. 1 and 2, the lower short arm of said angle-lever resting immediately over the pulley and shaft 21, that carries the pattern-chain 22. A spring 23 has one end bearing upon the upper arm of said angle-lever while its other end is seated in the frame of the machine, giving said spring a constant tendency to force the lower short arm of said angle-lever down upon the pattern-chain. The shaft 21 is operated intermittently by means of a lever 24, carrying a pawl 25, which acts upon the ratchet-wheel 26, for each reciprocation of said lever. The lever 24 is operated in one direction by the spring 27,

Fig. 2, and in the opposite direction by the cam 28, which cam rotates with the needle-cylinder and gives one stroke to said lever for every revolution of said cylinder.

5 E designates the cam-plate for the horizontal needles, said plate having on its under side the middle cam 29, which pushes the needles outwardly, and the two cams 30 and 31 for drawing the needles inwardly. I also provide
10 this cam-plate with a cam-slide 32, to which one end of the cam 31 is connected, said cam 31 being pivoted to the cam-plate at 33, so that it may be moved out or in to bring it into the position shown for drawing in the needles, or
15 so that it may be swung outwardly far enough not to draw in the needles. The cam 30 is stationarily affixed in place. The cam-slide 32 is connected to a pitman 34, the opposite end of said pitman being connected to the upper
20 arm of the angle-lever 35, the lower arm of said angle-lever lying immediately over the pattern-chain shaft and by the side of the lever 19, before described, both angle-levers being pivoted to the same shaft. This lever
25 is also held toward the pattern-chain by a spring 36, the same as the lever 19 is so held by the spring 23. The backward movement of the lever 35 under the influence of the spring 36 is regulated by means of the adjust-
30 ing-screw 37 in the cam-plate E, the end of which adjusting-screw strikes against the screw 38 that connects the pitman 34 with the cam-slide 32.

35 Prior machines have heretofore been provided with pattern-chains operated by the means herein shown and described, and with spring-pressed angle-levers for operating various parts of the machine, and in some instances such levers have been employed for
40 operating a cam-slide to move both of the cams under the cam-plate E, that draw the horizontal needles inwardly, and therefore I do not claim these parts of themselves.

45 I employ only one pattern-chain for operating both of the angle-levers 19 and 35, and I provide said chain with a series of narrow links, as shown at the right-hand side of the shaft 21 in Fig. 2, and with a series of higher or broad links 39. (Shown at the left-hand
50 side of the shaft 21 in Fig. 2.) I also provide the first one of the broad or high links 39 with a side cam 40, Figs. 1 and 2, which cam projects far enough to one side to engage the roller in the lower angle-arm of the lever 35.
55 Upon the shaft 21, at a point immediately under the roller of the angle-lever 35, is a wheel to limit the backward movement of said lever under the influence of the spring 36. This wheel, as illustrated, has its periphery formed of a piece of a chain; but its function is the same as an ordinary plain pulley.
60 When the machine is at work, with the narrow links passing over the shaft 21, the spring 23 holds the angle-lever 19 and connected parts in such a position that the cams 11 are
65 carried under the ends of the adjusting-screws 10 of the cam-operating levers 8, the

inclines of the cams passing said screws, so that they rest on the flat supporting-faces at the top of said incline to hold up said levers 70 8, thereby holding the cams 7 of the cam-cylinder B in their most depressed position, so as to draw the vertical needles downward and produce a loose fabric with long stitches for certain portions of the garment. When
75 the broad or high links of the pattern-chain engage the roller of the angle-lever 19, said lever and connecting-link 18 will be operated to move the rock-shaft 14, and through its arm 15 partially rotate the cam-ring 12, so as
80 to throw the cams 11 wholly out from under the screws 10 of the cam-adjusting levers 8, thereby permitting the cams 7 to be elevated, whereby the vertical needles will not be drawn down so far, and consequently a shorter stitch
85 with a firmer fabric will be produced. In addition to the tension of the yarn, the springs 41 will operate to elevate said cam-operating levers and cams. The adjusting-screws 42 may be turned, so as to stop the rise of the
90 cams 7 at any desired elevation, while the adjusting-screws 10 may be changed in position, so that said levers will depress the cams 7 a greater or less distance, as may be desired.

95 In order to make a dividing-mark and give the appearance of a seam between the sections of short and long stitches the side cam 40 on the first one of the broad or high links 39 acts upon the roller of the short arm of lever 35, thereby pushing the link 34 and cam-
100 slide 32 in a direction to throw the cam 31 outwardly, whereby the horizontal needles will not be drawn inwardly during one course and consequently will not knit, thereby forming a course of what is known as the "royal-
105 ribbed" fabric to make a dividing-line between the two sections—as, for instance, between the body of a sleeve and its cuff. After the side cam 40 has passed from under the roller of the angle-lever 35, the machine will knit
110 the regular ribbed fabric the same as when the narrow links are passing under the levers, excepting that the broad and high links act to produce a firm and close fabric with short stitches, and the narrow links produce
115 a looser fabric with longer stitches. As illustrated, there are only two cams 7 and two operating levers, but it is evident that these may be increased in number as may be desired, and all of them be operated simulta-
120 neously by the one cam-ring 12.

125 By making the cams 11 each with an inclined face and a flat face at the top of said incline, the machine is particularly adapted to have the cam-ring 12 moved automatically,
130 as it does not have to be stopped with great nicety at any particular point so long as it moves far enough to bring the flat faces under the ends of the screws. It also enables me to raise the lower ends of the screws 10
135 of the levers 8 to a certain point and to vary the throw of the needle-cams 7 by adjusting devices intermediate said flat faces and needle-cams.

I am aware that the application of George E. Nye for an improvement in knitting-machines, filed January 9, 1889, shows in combination a series of levers, needle-actuating cams mounted on the inner ends of the levers, and a hand-operated adjusting-ring common to the series of levers, the outer ends of said levers resting upon the inclines of said common ring, and I hereby disclaim the said combination.

I claim as my invention—

1. In a circular-knitting machine, the combination of the cam-cylinder having the movable cams 7, the cam-operating levers 8, cam-ring 12, having cams 11, a pattern operated by the machine, and operating devices intermediate said pattern and cam-ring for operating said cam-ring, substantially as described, and for the purpose specified.

2. In a circular-knitting machine, the combination of the cam-cylinder having the movable cams 7, the cam-operating levers 8, cam-ring 12, having cams 11, a pattern, the rock-shaft 14, and connecting mechanism between said pattern and rock-shaft, the latter having one arm connected with said cam-ring, and another arm connected with the pattern-controlled mechanism, substantially as described, and for the purpose specified.

3. In a circular-knitting machine, the combination of the cam-cylinder having cams 7, the cam-operating levers 8, having the adjusting-screws 10 at their outer ends, the cams 11, for acting on the ends of said screws, and mechanism for operating said cams, substantially as described, and for the purpose specified.

4. In a circular-knitting machine, the combination of the cam-cylinder having cams 7, the cam-operating levers 8, connected therewith, mechanism for operating said levers, and the adjustable stop-screws 41, for limiting the upward movement of said levers and cams, substantially as specified.

5. In a circular-knitting machine, the cam-cylinder having the cams 7, a pattern-chain,

and connecting mechanism for automatically controlling said cams, the cam 31, for producing the inward movement of the horizontal needles, the side cam 40 on said pattern-chain, and the angle-lever 35, one arm of which is engaged by said cam 40, and the other arm of which is connected to said needle-cam 31, substantially as described, and for the purpose specified.

6. In a circular-knitting machine, the cam-plate E for the horizontal needles, having a fixed cam 30 and a movable cam 31, for producing the inward movement of said horizontal needles, the angle-lever 35, connecting mechanism for said lever and movable cam, and a pattern-chain having a single cam 40, for imparting a short stroke to said lever for moving said cam 31 outwardly and letting it back to change the stitch for a single course, substantially as specified.

7. In a circular-knitting machine, the combination of the vertical and horizontal needles, the cam-cylinder, the cams 7, for moving said vertical needles, the cam 31, for controlling the inward movement of said horizontal needles, a pattern-chain having a connected series of narrow links, a connected series of broad links, and a side cam 40 at the junction of said two series, and connecting devices between said pattern and respective needle-cams, substantially as described, and for the purpose specified.

8. In a circular-knitting machine, the combination of the cam-cylinder having the needle-actuating cams, a series of cam-operating levers, a cam-ring 12, common to said series of levers, and the cams 11, mounted on said cam-ring 12, and having at the top of the incline of each cam 11 a flat supporting-face, substantially as described, and for the purpose specified.

DWIGHT P. MILLS.

Witnesses:

GEO. G. CROGG,
J. E. ROLLINSON.