



US00D967993S

(12) **United States Design Patent**
Tovey et al.

(10) **Patent No.:** **US D967,993 S**

(45) **Date of Patent:** **** Oct. 25, 2022**

(54) **HEAD LIGHT**

(71) Applicant: **Jaguar Land Rover Limited**, Coventry (GB)

(72) Inventors: **Simon Tovey**, Coventry (GB); **Paul Jobling**, Coventry (GB)

(73) Assignee: **Jaguar Land Rover Limited**, Coventry (GB)

(**) Term: **15 Years**

(21) Appl. No.: **29/736,379**

(22) Filed: **May 29, 2020**

Related U.S. Application Data

(62) Division of application No. 29/625,076, filed on Nov. 7, 2017, now Pat. No. Des. 889,697.

(30) **Foreign Application Priority Data**

May 11, 2017 (EM) 003996958

(51) **LOC (13) Cl.** **26-06**

(52) **U.S. Cl.** **D26/28**
USPC

(58) **Field of Classification Search**
USPC D12/86, 90-92, 114, 163, 169, 171-173, D12/181, 190, 196, 197, 199, 400; D26/28-36

CPC ... B62J 6/02; B62J 6/00; B60Q 3/0279; F21S 48/00; F21S 48/10; F21S 48/115; F21S 48/225; F21S 48/1233; F21S 48/1266; F21S 48/1388; F21S 48/2268; F21V 21/04

See application file for complete search history.

(56) **References Cited**

U.S. PATENT DOCUMENTS

D538,956 S * 3/2007 Ishii D26/28
D544,614 S * 6/2007 Markefka D26/28

D561,358 S * 2/2008 Tachibana D26/28
D690,852 S * 10/2013 Cooney D26/28
D703,848 S * 4/2014 Mays D26/28
D737,483 S * 8/2015 Roberts D26/28
D741,000 S * 10/2015 Beaven D26/139
D772,453 S * 11/2016 Wheel D26/28

(Continued)

Primary Examiner — Cary M Robinson

(74) *Attorney, Agent, or Firm* — Reising Ethington P.C.

(57) **CLAIM**

The ornamental design for a head light, as shown and described.

DESCRIPTION

FIG. 1 is a front left perspective view of the head light for a vehicle;

FIG. 2 is a front right perspective view thereof;

FIG. 3 is a rear right perspective view thereof;

FIG. 4 is a rear left perspective view thereof;

FIG. 5 is a front view thereof;

FIG. 6 is a rear view thereof;

FIG. 7 is a left side view thereof;

FIG. 8 is a right side view thereof;

FIG. 9 is a top view thereof;

FIG. 10 is a bottom view thereof; and,

FIG. 11 is a front left perspective view of the head light shown in FIGS. 1-10, with the head light mounted on a vehicle, and the rest of the vehicle shown in de-emphasized and half-tone portions so as to illustrate environmental structure, which portions form no part of the claimed design. More particularly, in FIG. 11, the inventive head light is shown within the broken line, and the elements shown outside the broken line form no part of the claimed design, but are instead included to shown environmental aspects thereof.

The broken lines shown in the drawings depict portions of the head light that form no part of the claimed design.

1 Claim, 11 Drawing Sheets

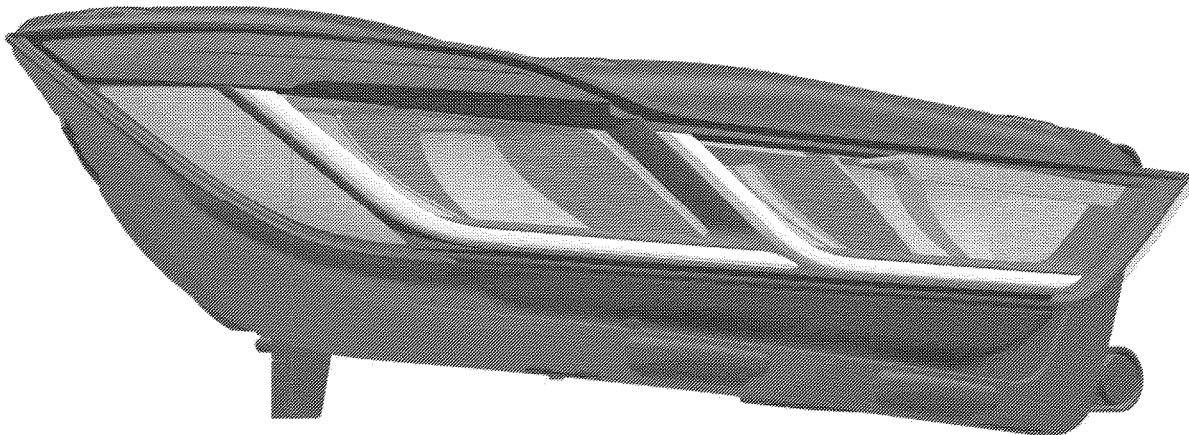

(56)

References Cited

U.S. PATENT DOCUMENTS

D807,548	S	*	1/2018	Lin	D26/28
D835,309	S	*	12/2018	Thomas	D26/28
D836,830	S	*	12/2018	Thomas	D26/139
D837,444	S	*	1/2019	Thomas	D26/139
D837,445	S	*	1/2019	Thomas	D26/139
D838,036	S	*	1/2019	Thomas	D26/139
D839,461	S	*	1/2019	Hegge	D26/28
D843,619	S	*	3/2019	Thomas	D26/28
D846,767	S	*	4/2019	Thomas	D26/28
D846,768	S	*	4/2019	Thomas	D26/28
D847,388	S	*	4/2019	Bernardi	D26/28
D847,389	S	*	4/2019	Thomas	D26/28
D848,648	S	*	5/2019	Thomas	D26/28
D889,697	S	*	7/2020	Tovey	D26/28

* cited by examiner

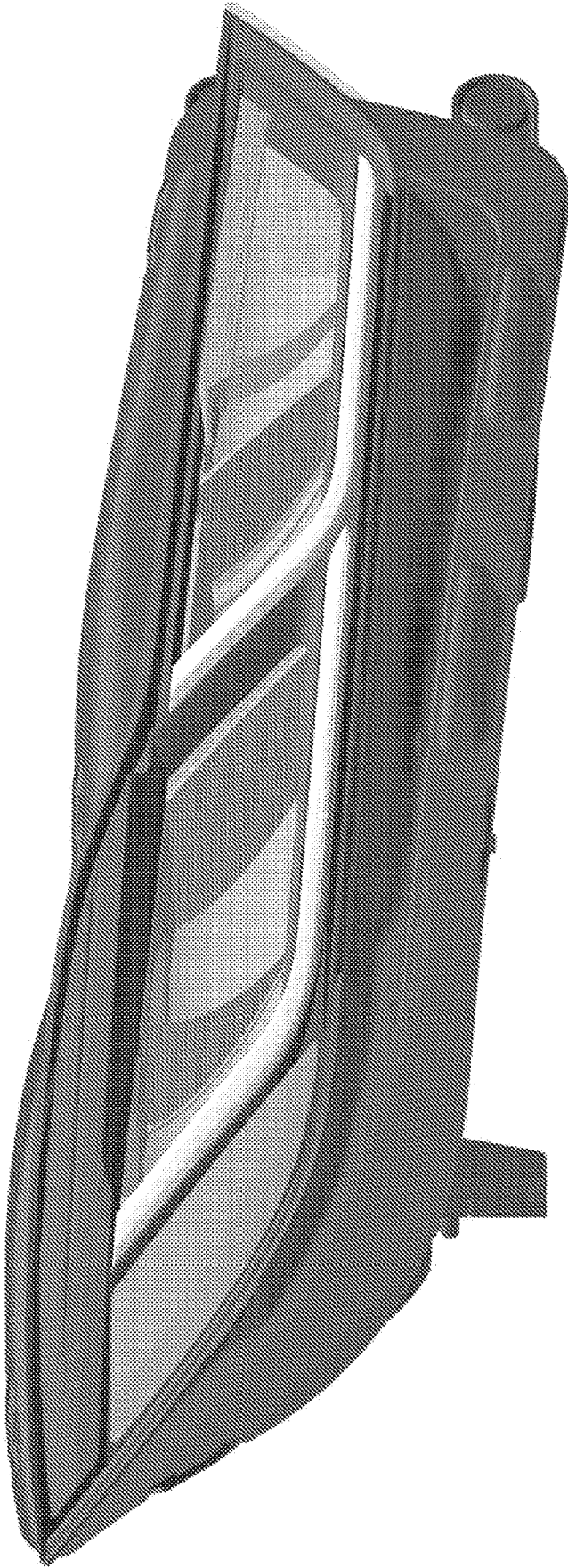

FIG. 1

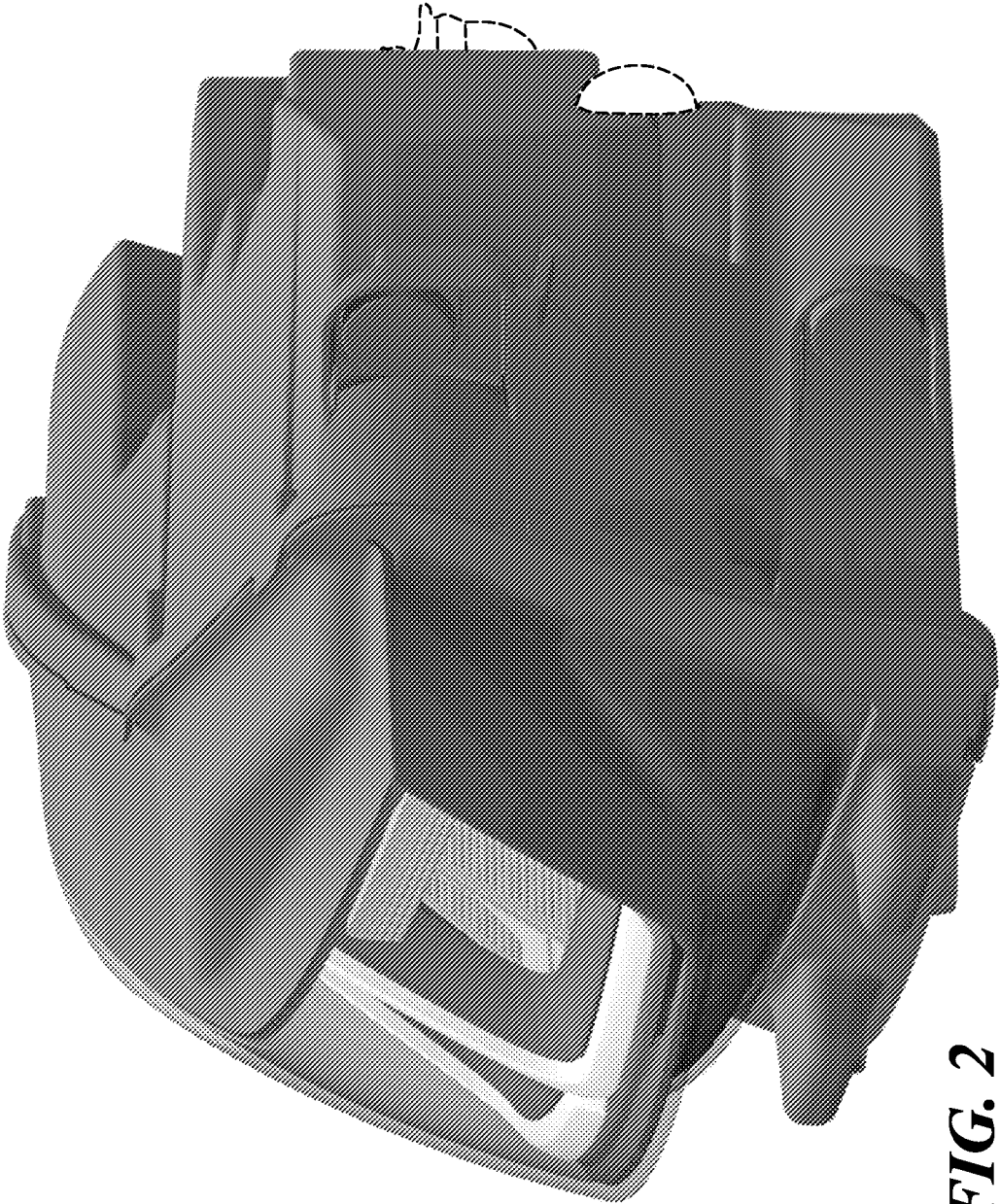

FIG. 2

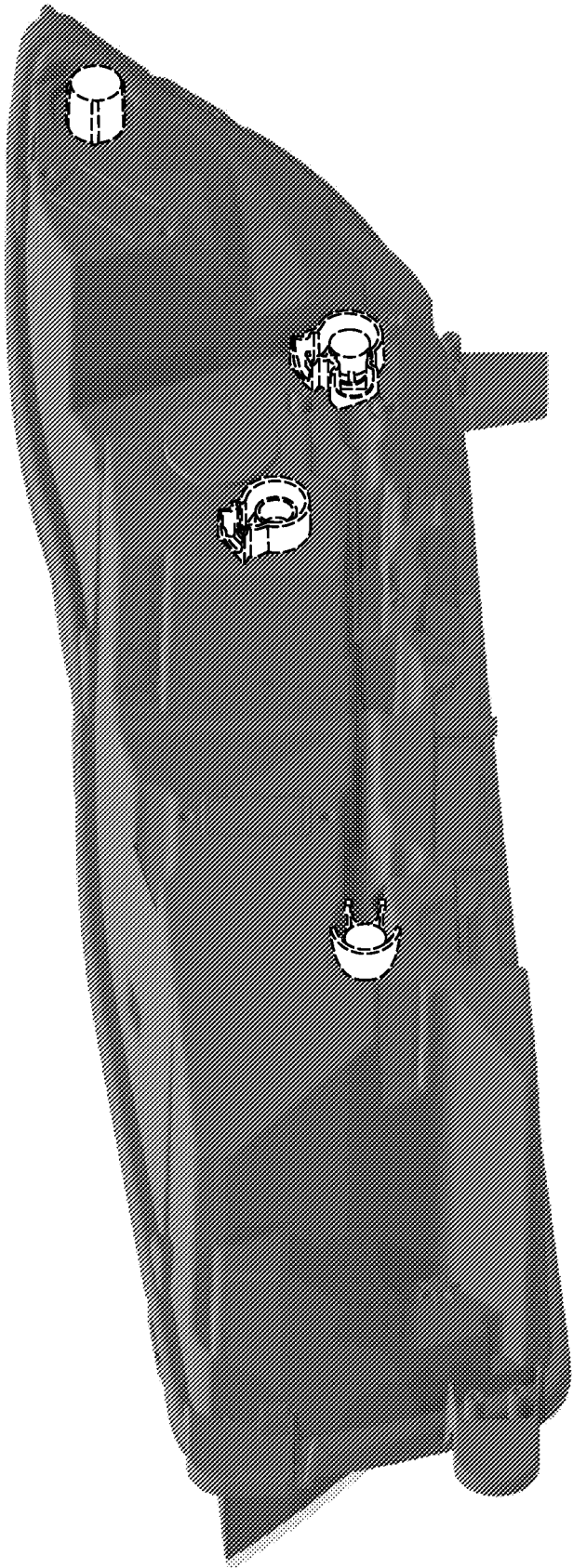

FIG. 3

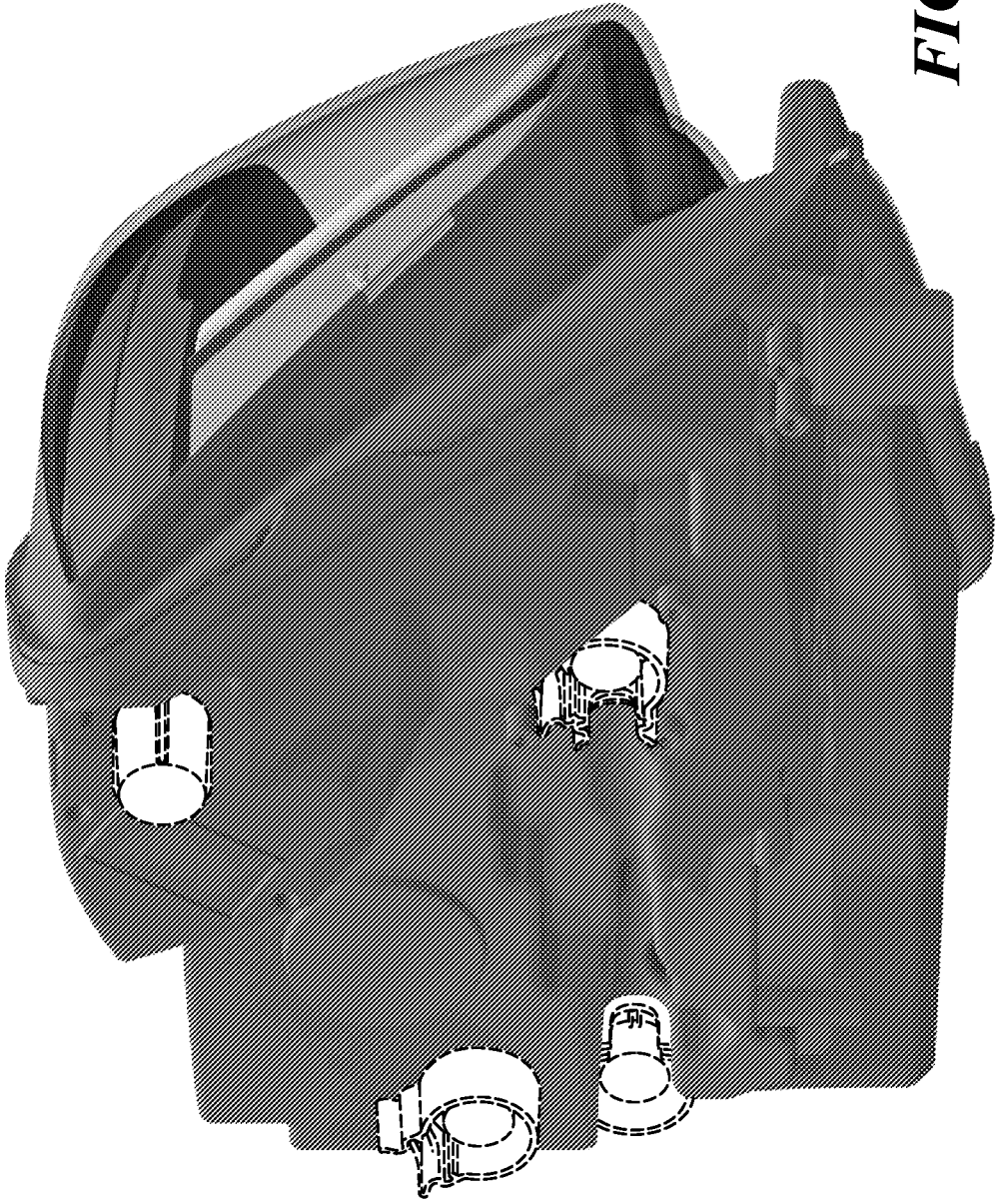

FIG. 4

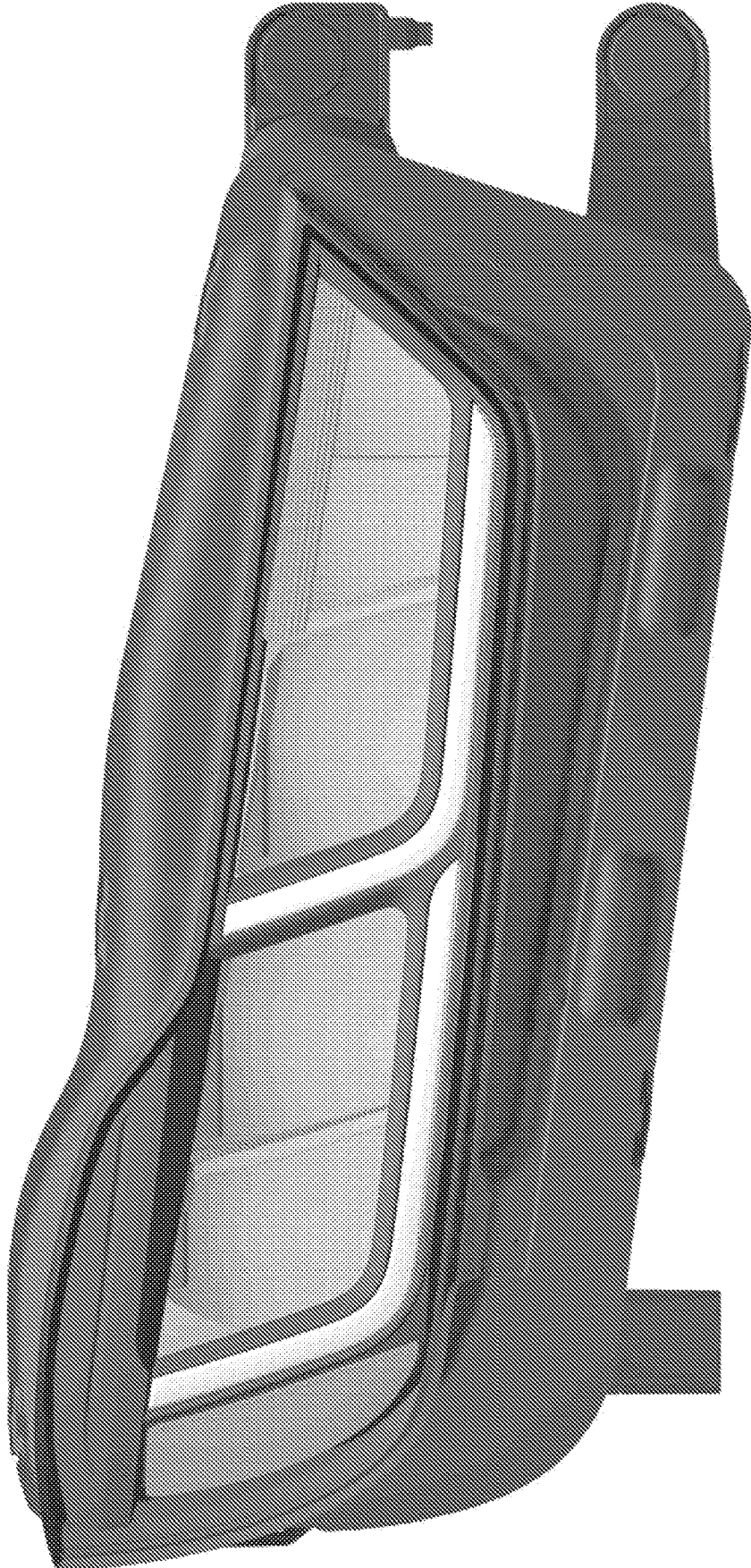

FIG. 5

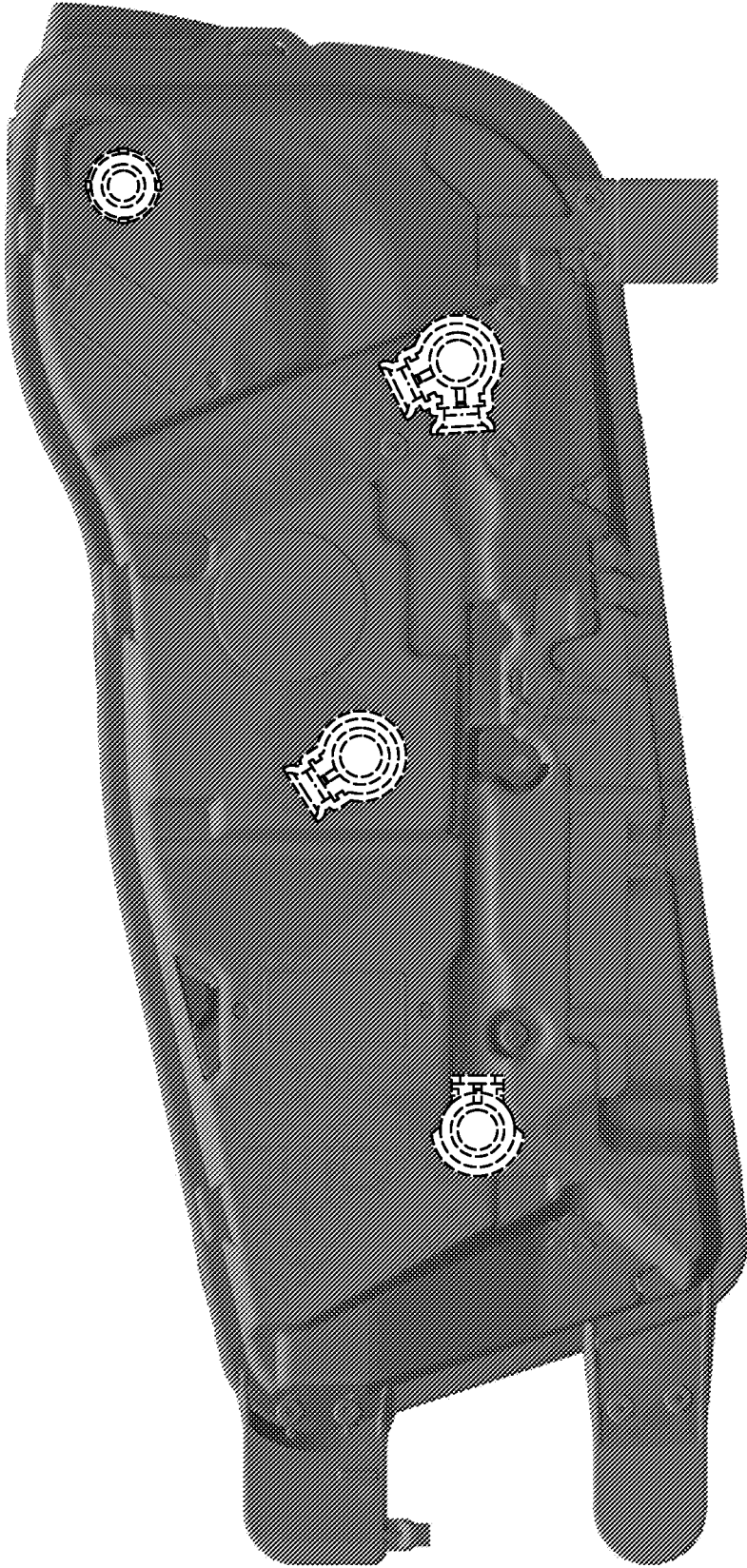

FIG. 6

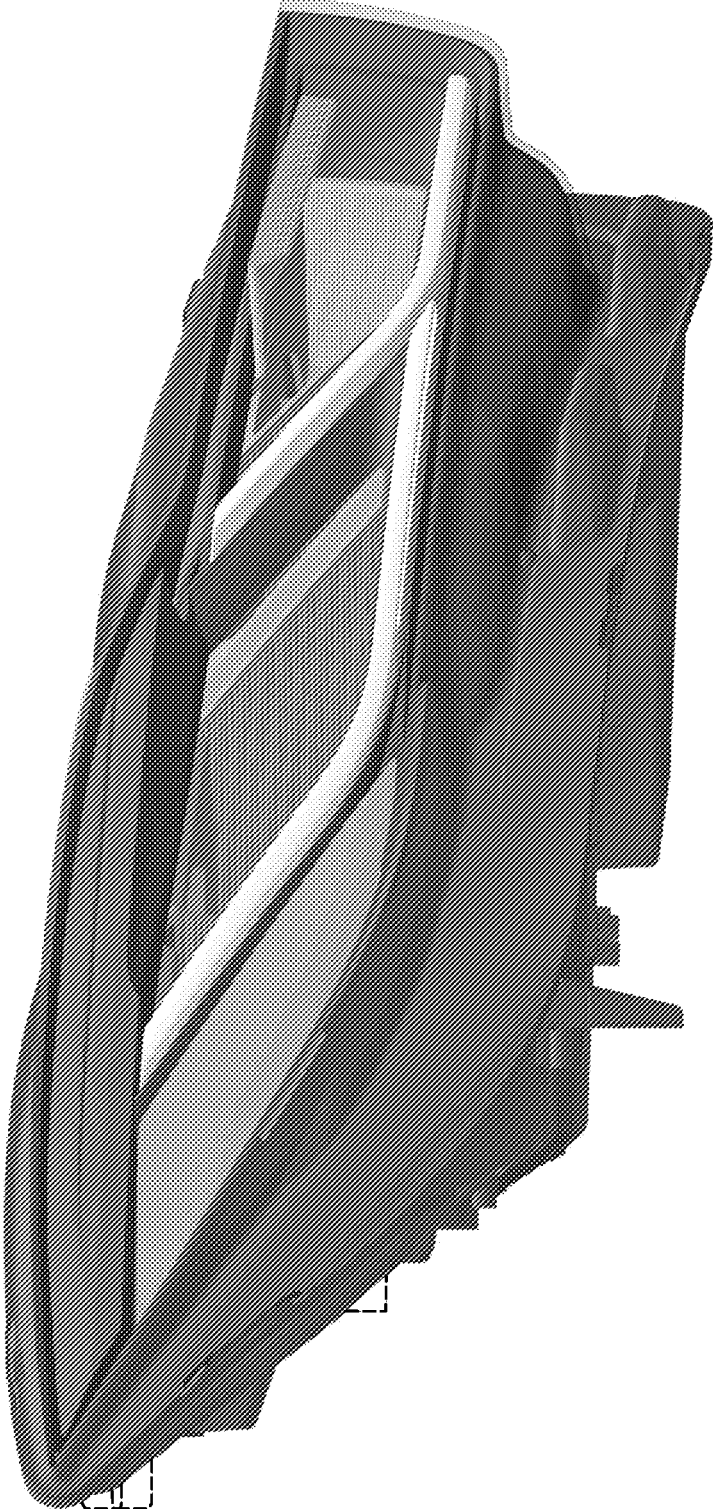

FIG. 7

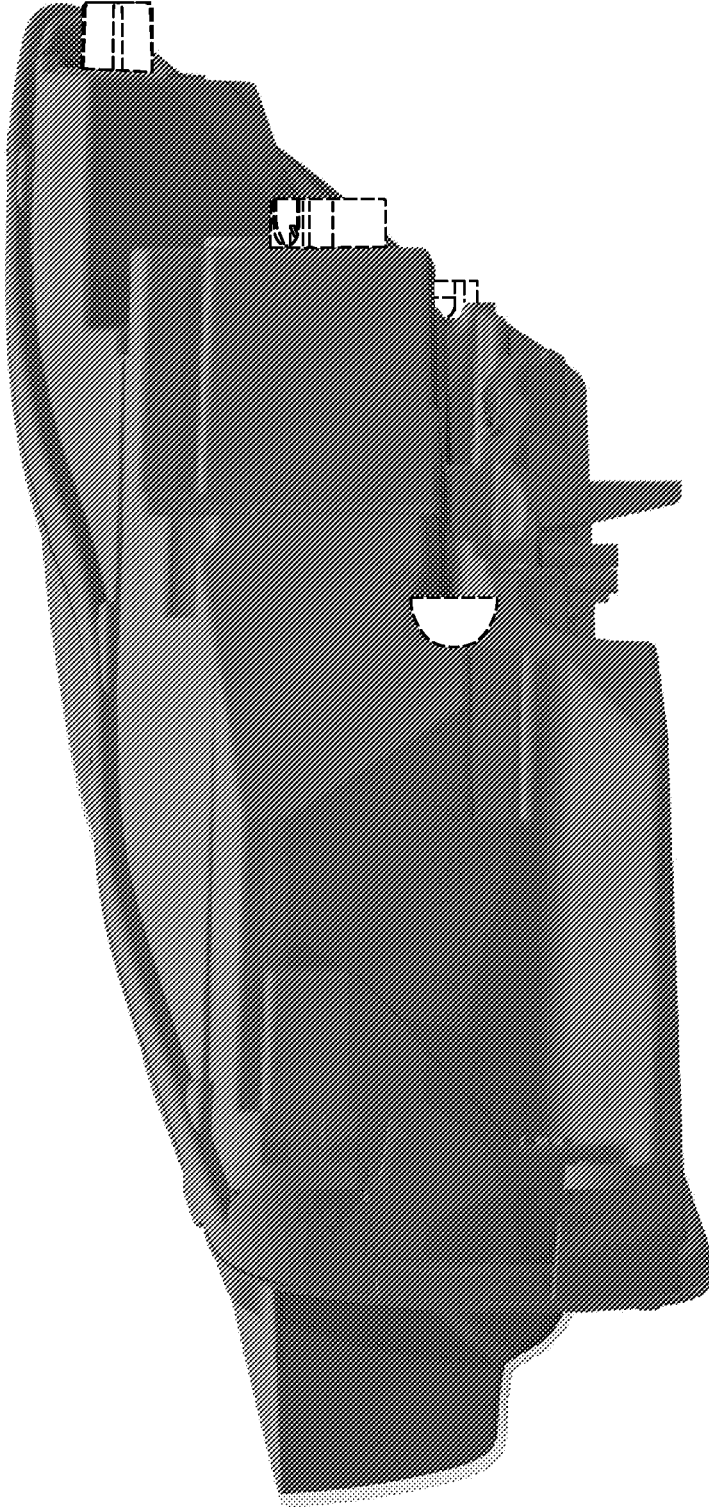

FIG. 8

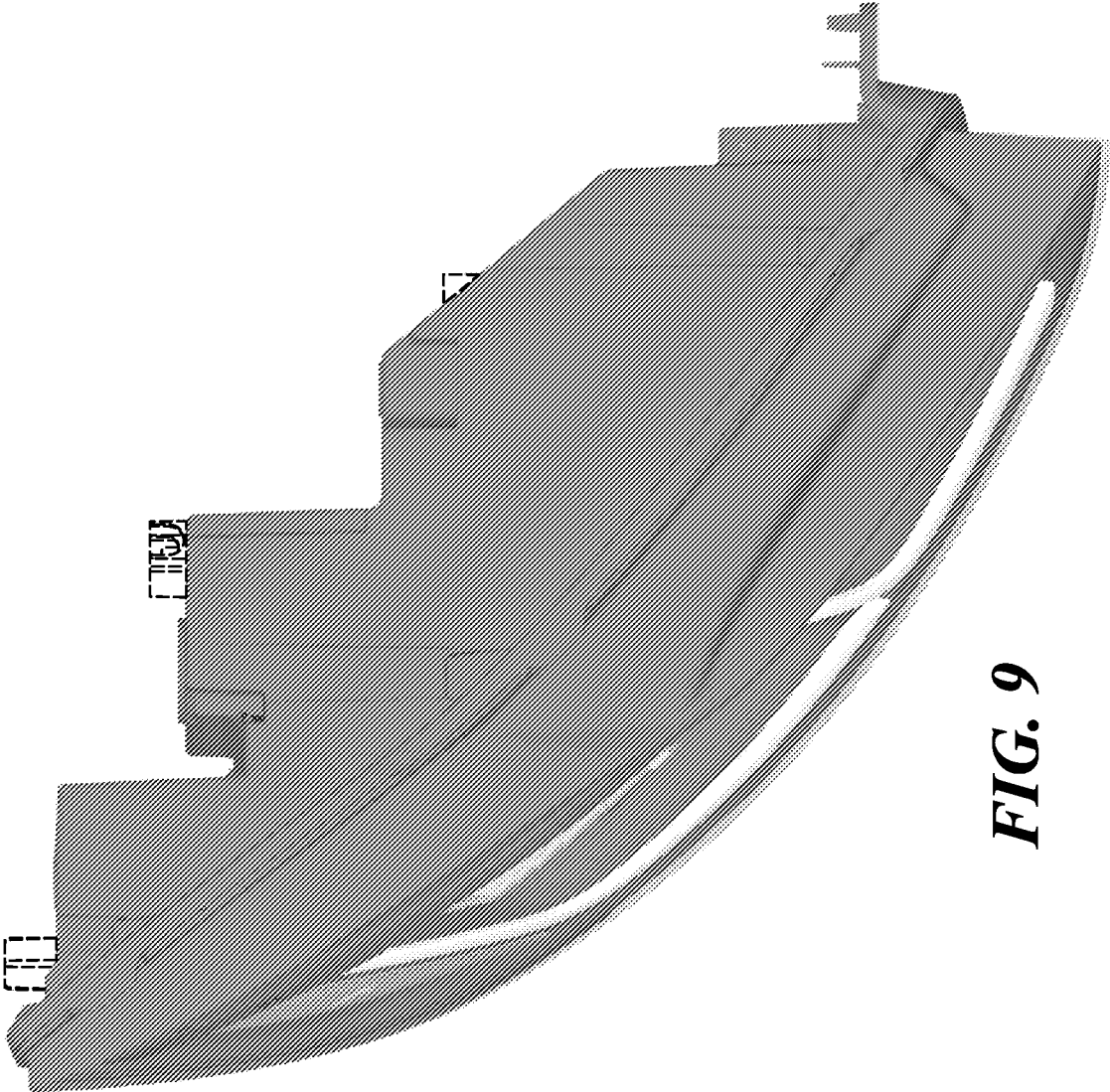

FIG. 9

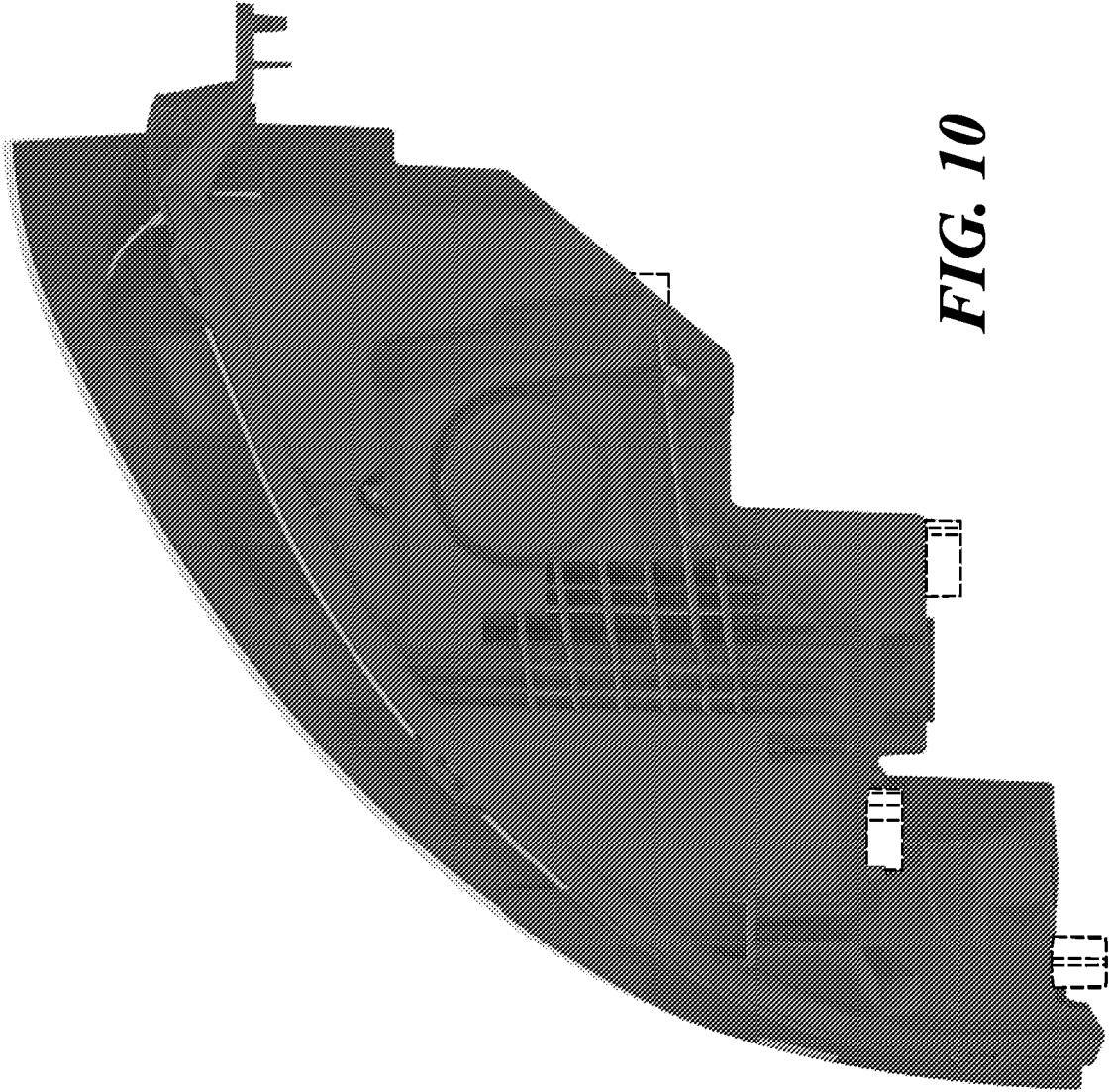

FIG. 10

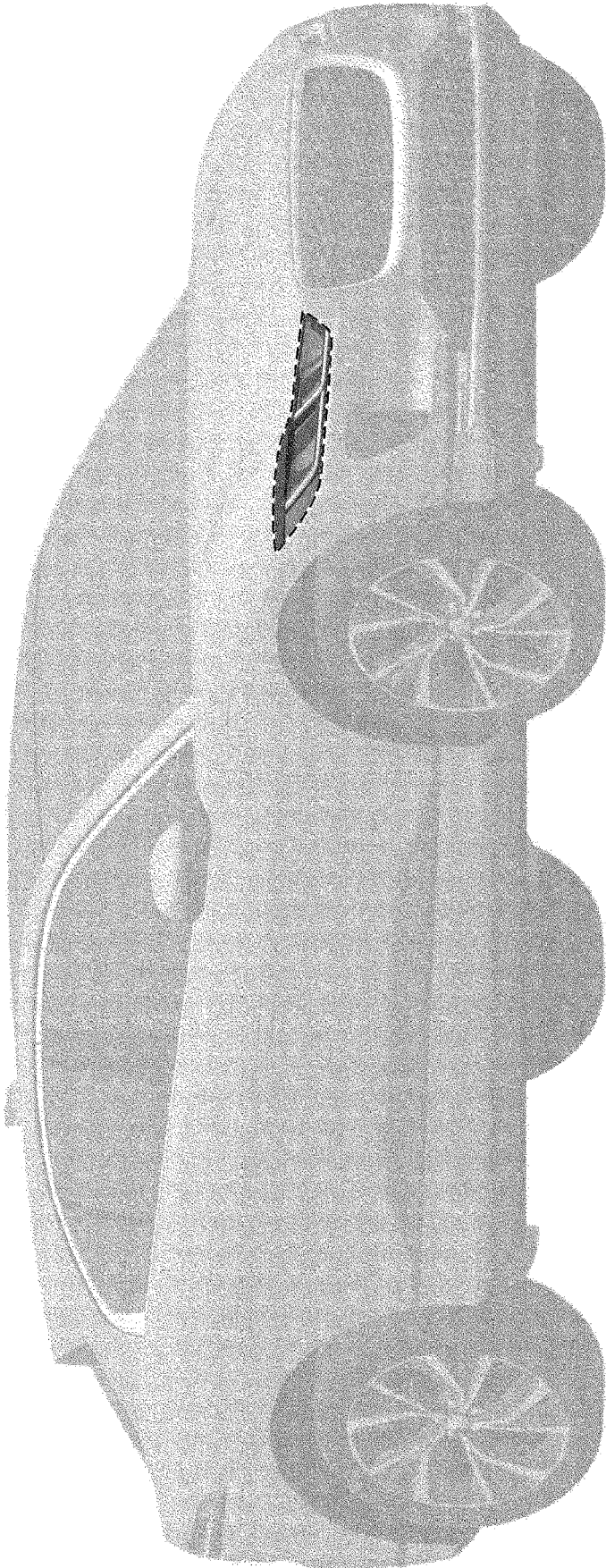

FIG. 11