



US00D919482S

(12) **United States Design Patent**
Lin et al.

(10) **Patent No.:** **US D919,482 S**
(45) **Date of Patent:** **** May 18, 2021**

- (54) **ELECTRIC SCOOTER**
- (71) Applicant: **Supersoco Intelligent Technology (Shanghai) Co., Ltd**, Shanghai (CN)
- (72) Inventors: **Jie Lin**, Shanghai (CN); **Yongqian Feng**, Shanghai (CN)
- (73) Assignee: **SUPERSOCO INTELLIGENT TECHNOLOGY (SHANGHAI) CO., LTD**, Shanghai (CN)
- (**) Term: **15 Years**
- (21) Appl. No.: **29/702,017**
- (22) Filed: **Aug. 16, 2019**
- (30) **Foreign Application Priority Data**

4,719,983	A *	1/1988	Bruzzone	B62K 13/00
				180/183
4,800,980	A *	1/1989	Hideo	B62J 7/04
				180/225
D314,166	S *	1/1991	Shively	D12/110
D361,741	S *	8/1995	Sofue	D12/110
D399,174	S *	10/1998	Takeshita	D12/110
D480,661	S *	10/2003	Kawawa	D12/110
D490,750	S *	6/2004	Hoshino	D12/110
D503,908	S *	4/2005	Tomomatsu	D12/110
D514,987	S *	2/2006	Hsiao	D12/110
D529,415	S *	10/2006	Shimada	D12/110
D537,386	S *	2/2007	Mizuta	D12/110
D537,756	S *	3/2007	Kitayama	D12/110
D574,300	S *	8/2008	Kitayama	D12/110
D602,402	S *	10/2009	Takahashi	D12/110
D610,490	S *	2/2010	Wong	D12/110
D629,721	S *	12/2010	Takeo	D12/110
D644,961	S *	9/2011	Watanabe	D12/110
D654,402	S *	2/2012	Lambri	D12/110
D657,722	S *	4/2012	Lambri	D12/110
D662,860	S *	7/2012	Devernay	D12/110

(Continued)

Jul. 22, 2019 (CN) 201930391798.0

- (51) **LOC (13) Cl.** **12-11**
- (52) **U.S. Cl.**
USPC **D12/110**
- (58) **Field of Classification Search**
USPC D12/110, 111, 117, 128-133; D21/432, D21/538
CPC B62K 11/00; B62K 11/02; B62K 11/04; B62K 11/10; B62K 17/00; B62K 19/00; B62K 2202/00; A61G 5/04; A61G 5/041-047; A61G 2005/048
See application file for complete search history.

Primary Examiner — Darlington Ly
(74) *Attorney, Agent, or Firm* — McClure, Qualey & Rodack, LLP

(57) **CLAIM**

The ornamental design for an electric scooter, as shown and described.

DESCRIPTION

FIG. 1 is a top, rear, and right side perspective view of an electric scooter embodying our new design;
FIG. 2 is front elevation view thereof;
FIG. 3 is a rear elevation view thereof;
FIG. 4 is a right side elevation view thereof;
FIG. 5 is a left side elevation view thereof;
FIG. 6 is a top plan view thereof;
FIG. 7 is a bottom plan view thereof; and,
FIG. 8 is a top, front, and left side perspective view thereof.

1 Claim, 8 Drawing Sheets

(56) **References Cited**
U.S. PATENT DOCUMENTS

4,536,005	A *	8/1985	Tanaka	B62J 17/06
				16/334
4,715,465	A *	12/1987	Takahashi	B62J 17/00
				180/219

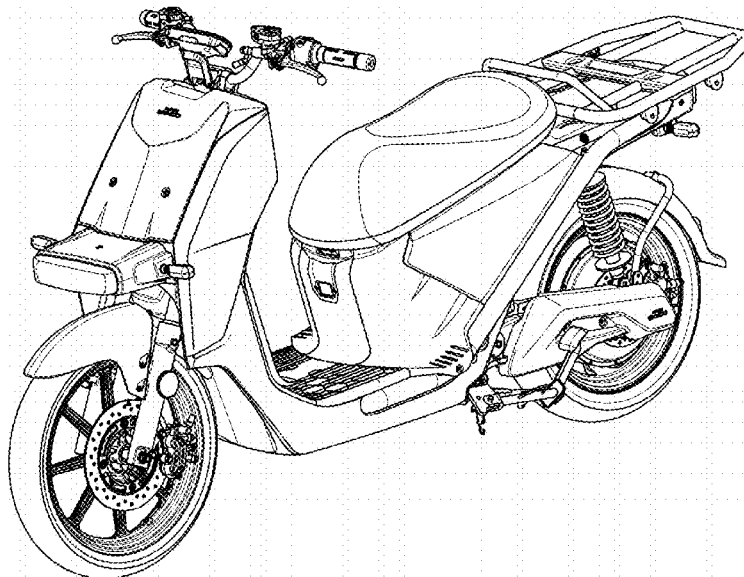

(56)

References Cited

U.S. PATENT DOCUMENTS

D670,205	S	*	11/2012	Takakuwa	D12/110
D678,128	S	*	3/2013	Lambri	D12/110
D678,129	S	*	3/2013	Kubota	D12/110
D726,076	S	*	4/2015	Arai	D12/110

* cited by examiner

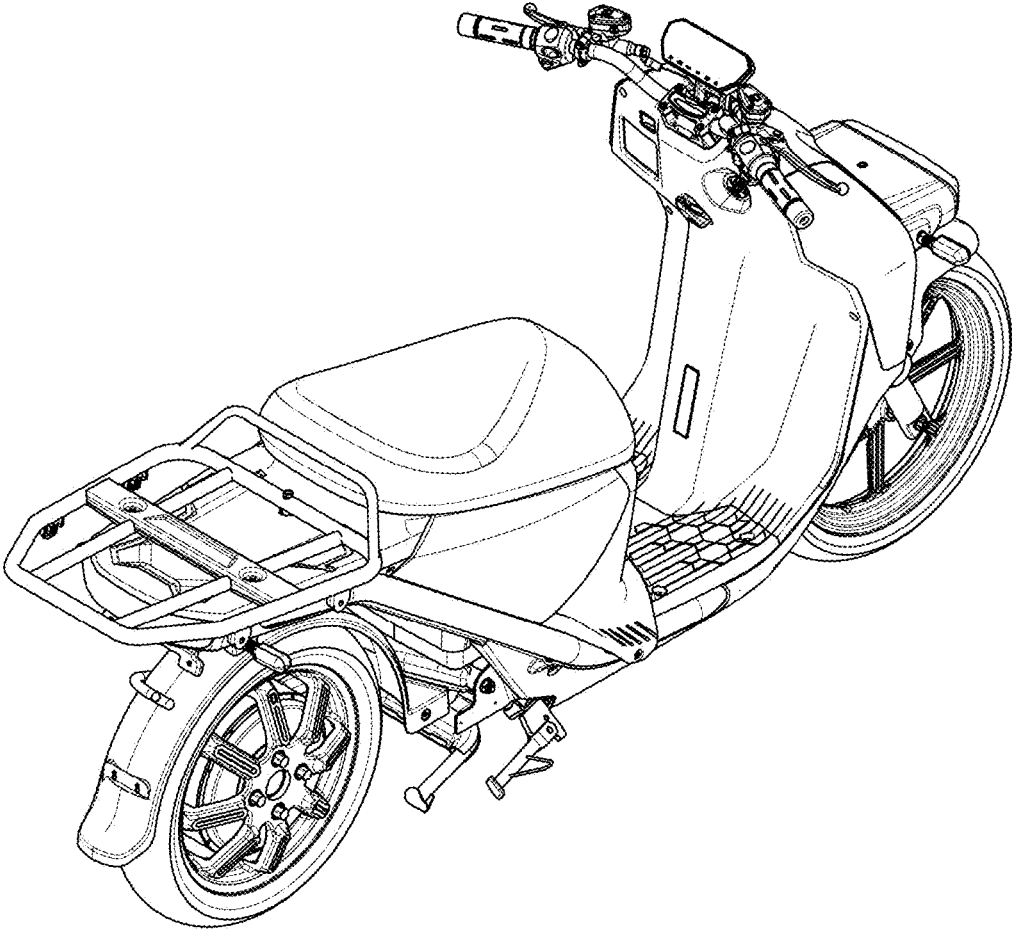

FIG. 1

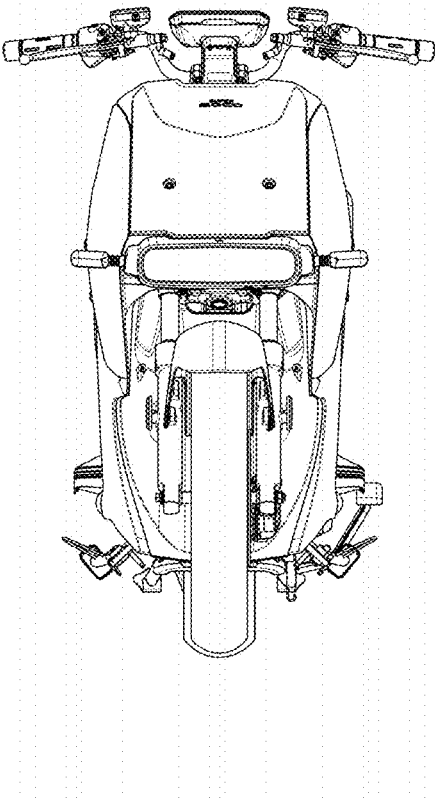

FIG. 2

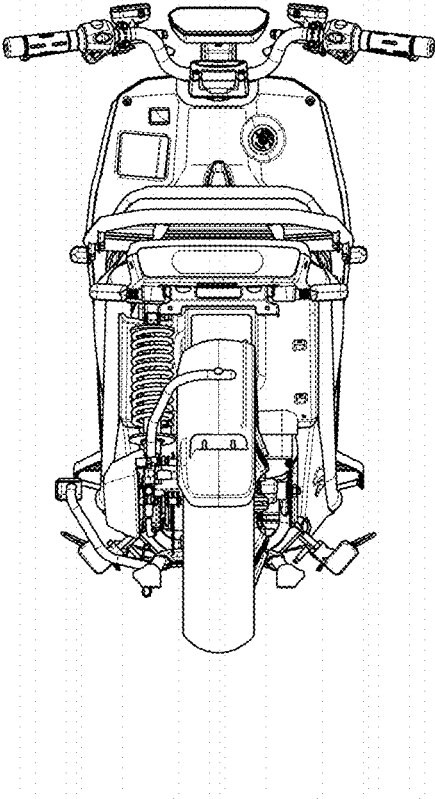

FIG. 3

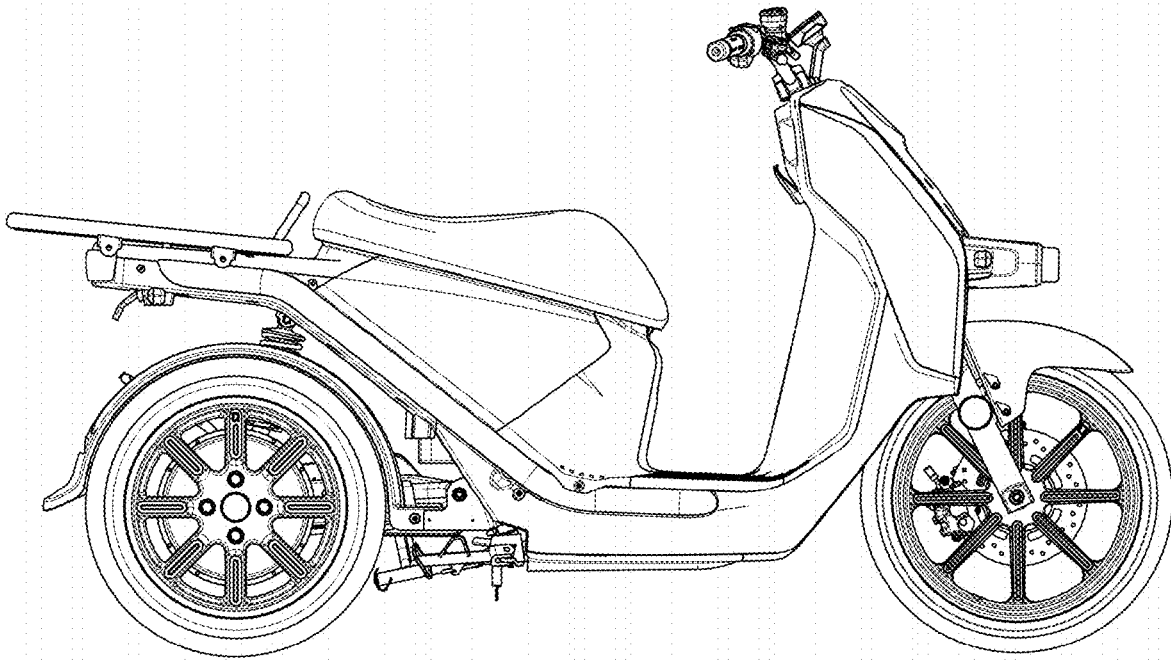

FIG. 4

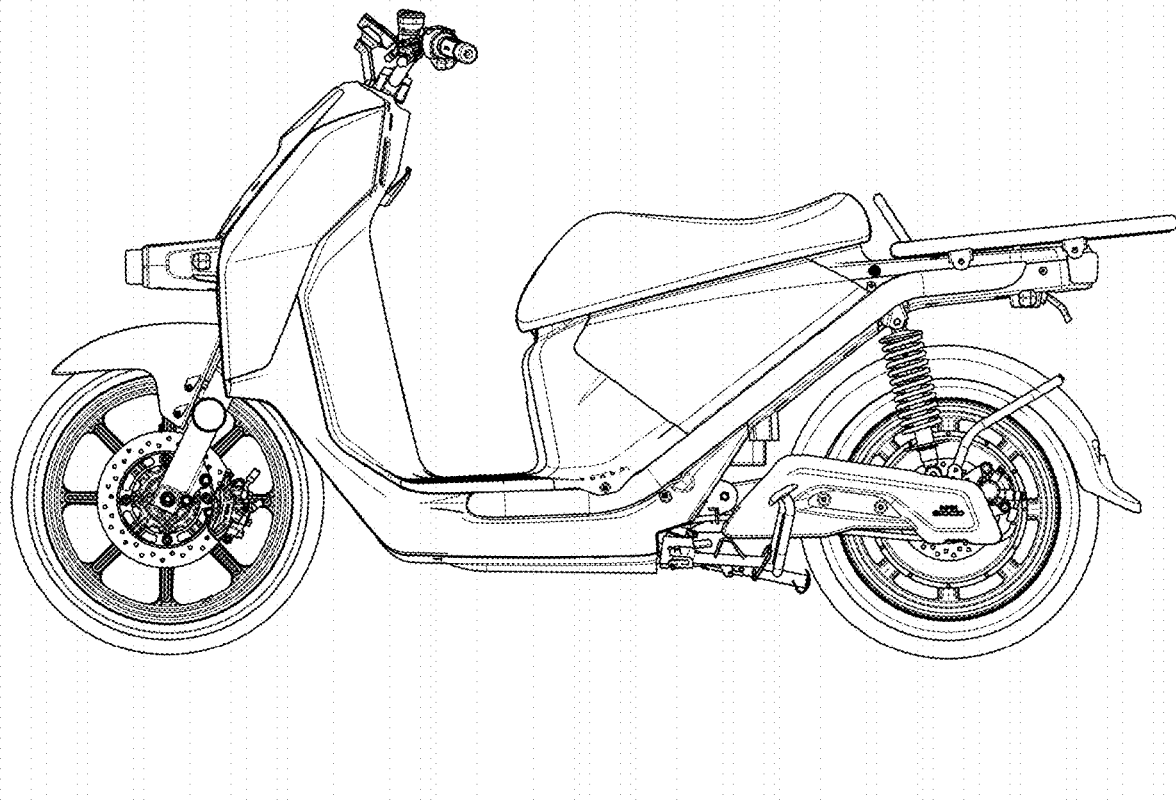

FIG. 5

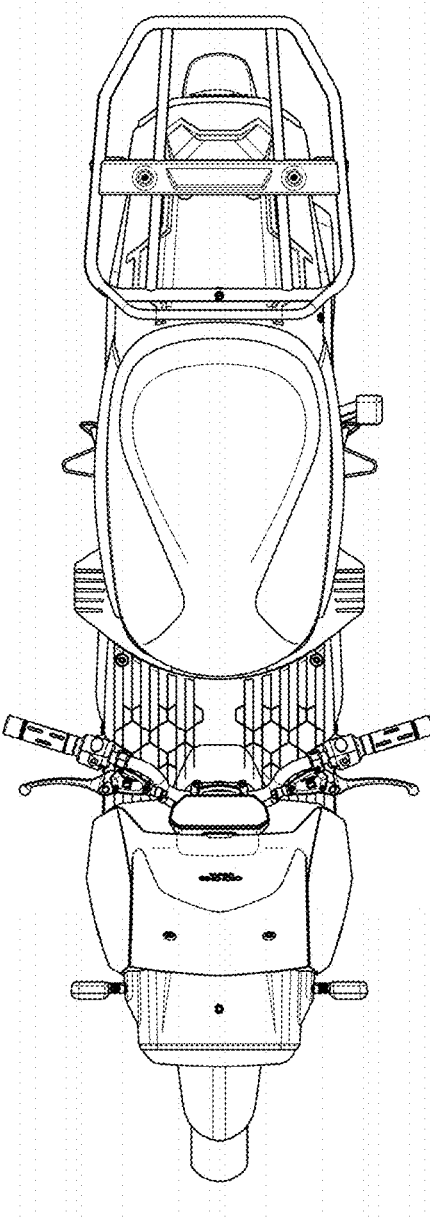

FIG. 6

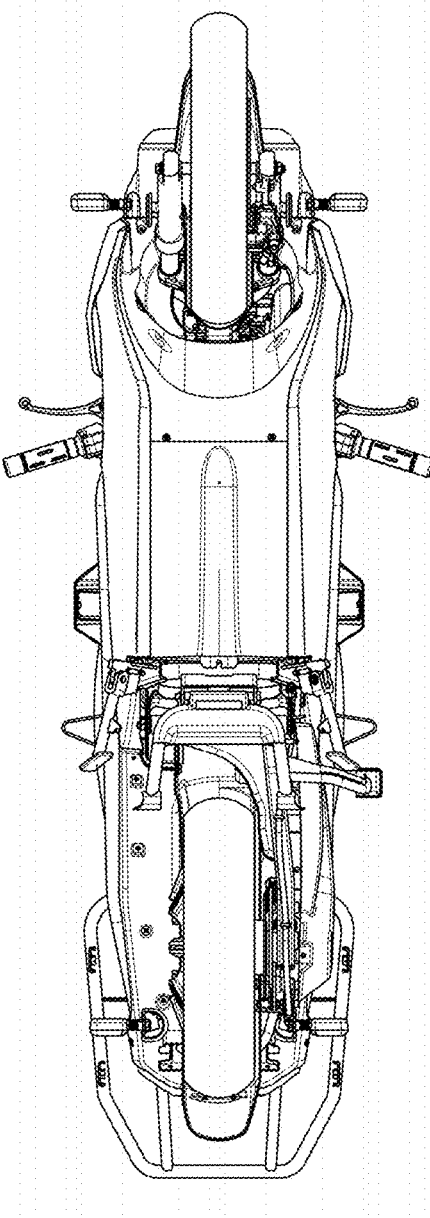

FIG. 7

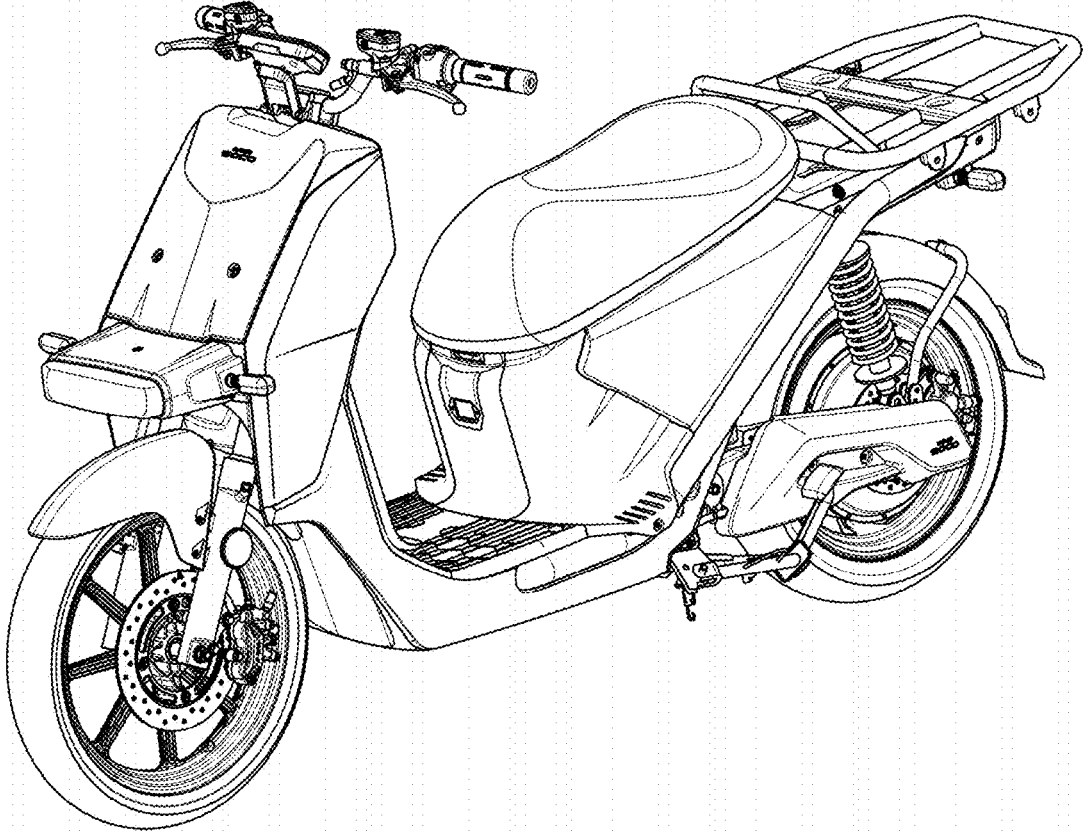

FIG. 8