



Jan. 22, 1957

A. F. WHILLOCK ET AL.

2,778,638

APPARATUS FOR STACKING LETTERS AND LIKE ARTICLES

Filed June 22, 1951

3 Sheets-Sheet 2

*Fig. 3.*

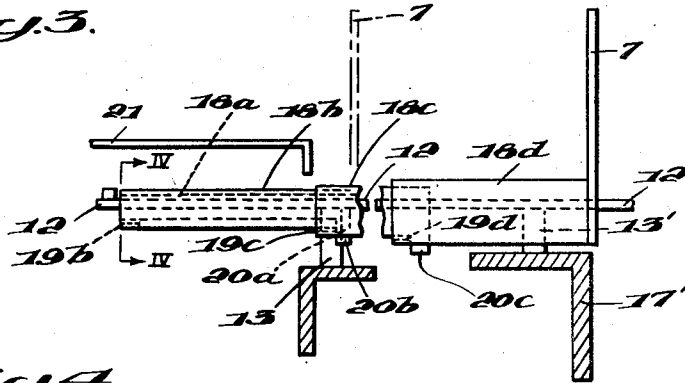

*Fig. 4.*

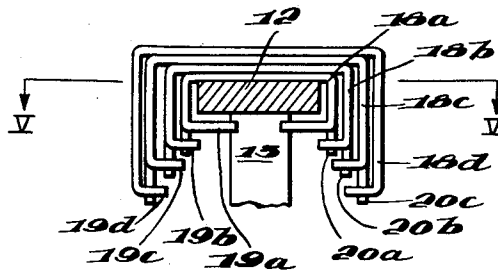

*Fig. 5.*

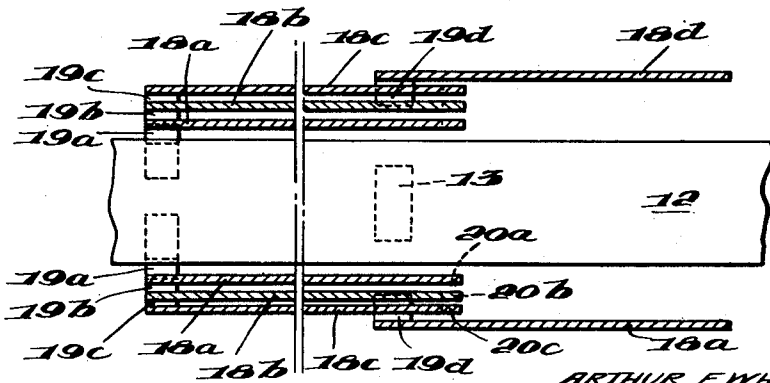

INVENTORS

ARTHUR F. WHILLOCK,  
FRANCIS E. WILLIAMS,

BY

*Hall & Houghton*

ATTORNEYS

Jan. 22, 1957

A. F. WHILLOCK ET AL

2,778,638

APPARATUS FOR STACKING LETTERS AND LIKE ARTICLES

Filed June 22, 1951

3 Sheets-Sheet 3

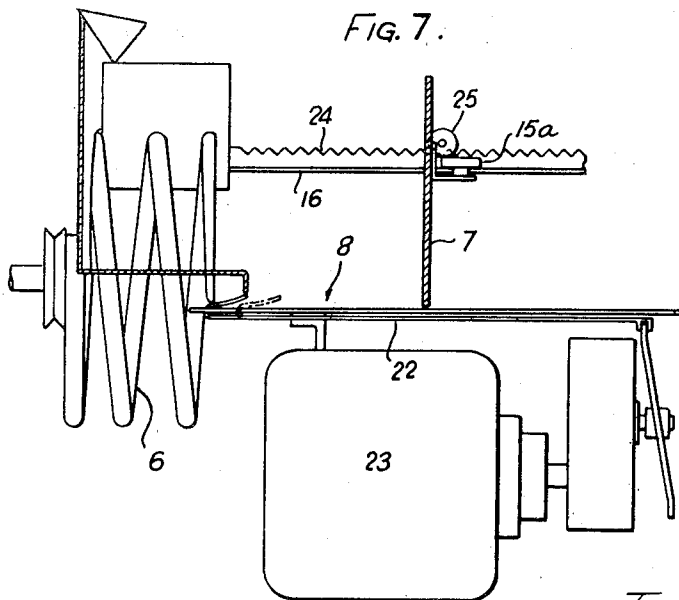
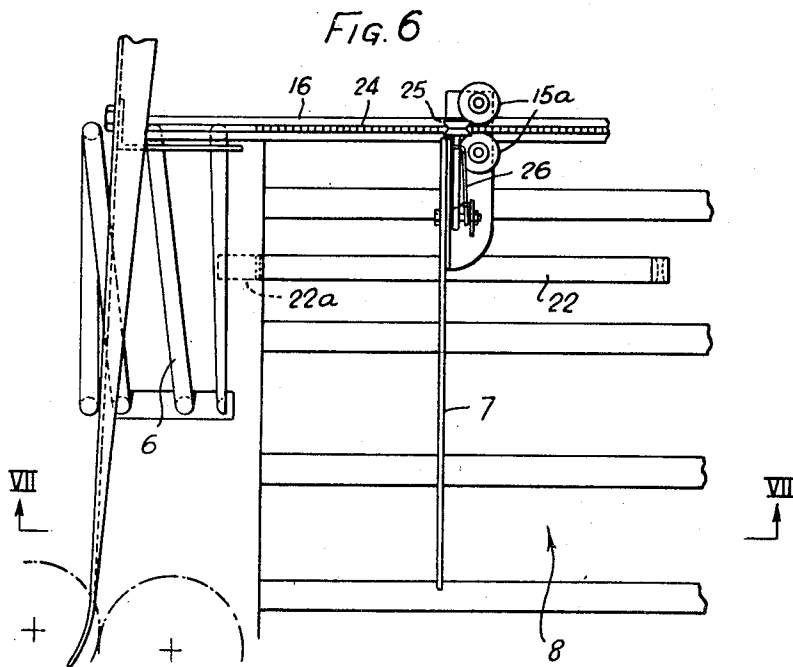

Inventors,  
Arthur F. Whillock,  
Francis E. Williams,  
by *Hall & Houghton*  
Attorneys.

1

2,778,638

**APPARATUS FOR STACKING LETTERS AND LIKE ARTICLES**

Arthur Frederick Whillock, Chesham, and Francis Edward Williams, Rickmansworth, England, assignors to Hall Telephone Accessories Limited, London, England

Application June 22, 1951, Serial No. 233,084

Claims priority, application Great Britain June 23, 1950

8 Claims. (Cl. 271—87)

This invention relates to apparatus for stacking letters, cards, thin packets, cheques and like articles, hereinafter referred to as "letters," which are ejected or fed one by one in a generally vertical orientation, by a generally horizontal movement in the plane of the letter, from a machine or other device for handling or treating the letters. Such a machine may, for example, be a stamp cancelling machine or a sorting machine. More particularly, although not exclusively, the invention is concerned with stacking apparatus constructed and arranged to operate as described in British patent specification No. 671,827.

The earlier specification referred to describes apparatus using a driven helix or two or more driven helices to which letters are passed one at a time and which constrains or constrain the letters to form a stack in a trough containing a slidably supported back rest for the stack. It has been found that there is a tendency for the letters stacked between the front of a stack feeding helix and the back rest to press too heavily against the face of the helix as the size of the stack is increased, resulting in a tendency for the letters at the front of the stack to be twisted out of the stack by the helix. The sliding friction between the bottom edges of the letters and the tray on which they rest also has the effect of tending to make the letters lean away from the helix as the stack is built up, instead of remaining vertical in the stack, and this may lead ultimately to bursting of the stack.

According to the present invention, in stacking apparatus of the kind referred to, means are provided which serve to reduce or eliminate pressure of the stacked letters or other articles against a feeding helix and sliding friction between the stacked letters and a floor or platform on which they rest by facilitating free control or assisted traverse of the back rest for the stack of letters and/or by providing a movable floor for the articles.

In one form of apparatus according to the invention, the floor or platform upon which the stacked letters rest is constituted by a series or several series of telescopic sections including or each including a section which supports and carries the back rest, the arrangement being such that displacement of the back rest to accommodate the increasing length of the stack of letters is accompanied by extension of the telescopic floor or platform sections so that the relative movement between the floor or platform and letters resting thereon is eliminated or substantially reduced.

In another form of apparatus according to the invention, means separate from the feeding helix are provided for positively urging the stack of letters in the direction of movement of the stack so as to relieve the helix from the pressure of the growing stack and positively to effect the traverse of the back rest and stack longitudinally of the stacking floor or platform.

The separate stack-displacing means referred to in the preceding paragraph may conveniently be in the form of a periodically displaced member, e. g. a reciprocating

2

finger or hook means, which is or are caused to engage the foremost or last fed letter of the stack as it is fed thereto by the helix and draw the letter towards the end of the stack and in the direction of traverse of the stack and back rest.

The retreating traverse of the stack and back rest may conveniently be controlled by braking means, e. g. a spring-loaded detent carried by the back rest and cooperating with a fixed toothed rack or friction member.

In order that the invention may be clearly understood and readily carried into effect, alternative forms of apparatus constructed and arranged to operate in accordance therewith will hereinafter be described in greater detail, by way of example and with reference to the accompanying diagrammatic drawings in which:

Fig. 1 is a partial plan view of a letter stacking apparatus embodying a single feeding helix and provided with a telescopic letter-supporting floor or platform according to the present invention, and showing such floor partially extended;

Fig. 2 is a side elevational view thereof looking in the direction of the arrow II, Fig. 1, and also showing the floor partly extended;

Fig. 3 is a partially cut away side elevational view drawn to a larger scale, of the telescopic floor or platform, and showing the telescoping floor partially extended in solid lines with the retracted or initial position of the back plate 7 shown in phantom lines;

Fig. 4 is a detail view, taken on line IV—IV of Fig. 3 and drawn to a larger scale, showing the telescoping floor members in rear end elevation, and the supporting bar therefor in cross section;

Fig. 5 is a section taken along the line V—V of Figure 4, but showing the parts in the relative position of Figure 2;

Fig. 6 is a plan view of a modified form of the letter stacking apparatus shown in Fig. 1, provided with means for drawing the stacked letters away from the feeding helix and towards the back rest in accordance with the invention and showing the back-rest, in partially extended position; and

Fig. 7 is a cross sectional view taken on line VII—VII of Fig. 6.

As previously indicated above, the present invention is particularly applicable to apparatus of the form described in British patent specification No. 671,827, and the accompanying drawings, more particularly Figs. 1 and 5 thereof, diagrammatically illustrate certain forms of such apparatus in which letters diverted from a conveyor bolt (not shown) by a diverter vane or blade 1 and directed thereby through a chute 2 to inversely rotating cooperating feed rollers 3, 4 are projected by the latter with the aid of a vertical guide plate 5 across a raised portion 21 of a floor or platform 8 into a rotating helix 6 which feeds the letters along the platform 8 and towards a back rest 7 slidably supported in a letter-stacking trough constituted by side guide walls 9 and platform 8 upon which the letters are stacked on edge as they are passed between the side guide walls 9 from the feeding helix 6. The raised portion 21 of the platform 8 is slotted to accommodate the rotating convolutions of the feeding helix 6 and extends diametrically thereof, the platform 8, which forms the floor of the letter-stacking trough, being thus downwardly stepped immediately behind the output end of the helix 6 so that letters fed into the trough by the helix drop down on their edge on to the lower part of the platform.

A rod 16 extending along one side of the stacking trough at the top thereof provides a horizontal slideway and support for an angle bracket 11, one limb 11a of which has the back rest 7 attached thereto so as to extend across the platform 8 between the side guide walls

9. The other limb 11*b* of the bracket carries co-operating rotatable grooved runners 15 and a fixed groove block 14 which slidably engage the rod 16 therebetween in such a manner as to permit the bracket 11 and back rest 7 to slide back and forth along the rod 16 and also to be rotated about the longitudinal axis of the rod to facilitate raising the back rest out of the trough when it is desired to remove a stack of letters therefrom.

In applying one form of the invention to the apparatus shown in Figs. 1 and 2, the lower part of the platform or trough floor 8 comprises spaced parallel bars or strips 12 extending longitudinally of the stacking trough and supported upon supports 13, 13' extending upwardly from transverse frame members 17, 17' of the apparatus.

As shown in detail in Figs. 3, 4, and 5, each bar or strip 12 provides a support and longitudinal slideway for a longitudinally telescopic platform unit comprising a series of interesting telescopic hollow metal sections 18*a*-18*d* inverted U-shape in cross section and with flat, smooth-finished or polished bearing surfaces. Sections 18*a*, 18*b*, 18*c* and 18*d* are provided at the ends thereof nearest to the output end of the helix 6, i. e. their inner ends with inwardly extending lateral projections, 19*a*, 19*b*, 19*c*, and 19*d*, respectively, and the sections 18*a*, 18*b*, and 18*c* are provided at the other or outer ends thereof, with downwardly extending projections 20*a*, 20*b*, and 20*c* respectively.

The outer ends of the sections 18*d* support the back rest 7, and the bars 12 extend beneath the upper portion 21 of the floor or platform, to enable the sections 18, when in the telescoped or initial position, to slide under the portion 21, so that the back rest 7 lies adjacent the said portion at the delivery end of the helix. In the said initial position of the telescopic sections, and upon feeding letters through the helix 6, the letters will be successively stacked against the back rest 7, which, together with the supporting floor sections 18*d*, will move outwardly, the sections 18*d* sliding on the sections 18*c* until the lateral projections 19*d* of the sections 18*d* engage the downward projections 20*c* of the sections 18*c*. The sections then occupy the position shown in Figure 2 and it will be apparent that due to the outward movement of the sections 18*d*, as the letters are stacked against the back rest 7, sliding movement of the letters longitudinally of the sections 18*d* is substantially eliminated.

Upon feeding further letters from the helix 6, the sections 18*c* will be pulled outwardly due to the pressure of the stack of letters on the back rest 7 and by reason of the engagement of the projections 19*d* with the projections 20*c*, the sections 18*c* sliding over the sections 18*b*, until the projections 19*c* of the sections 18*c* engage the projections 20*b* of the sections 18*b*, which will, in their turn, be pulled outwardly by the sections 18*c*, and so on until the sections reach the fully extended position shown in Figure 3, the lateral projections 19*a* of the section 18*a* engaging the support 13 to prevent further outward movement of the back rest 7.

It will be apparent that as the letters are fed on to each succeeding section, the section moves in the direction of feed so that sliding movements of the letters longitudinally with respect to each section is substantially eliminated.

Figure 5 is a section taken along the line V-V of Figure 4 but showing the floor sections in the position of Figure 2, i. e. with only the section 18*d* in the extended position.

As will be evident from consideration, especially of Fig. 4, the construction shown embodies an exemplary means for restraining movement of the sections 18*d*, 18*c*, 18*b* and 18*a*, respectively, each until the preceding section has been moved to its full extent relative to the section following it. Such means, in the form shown, relies on the well known fact that when two solid bodies are in contact, the maximum static friction between them, measured by the force required to slide one over the

other, is (1) directly proportioned to the total pressure exerted between the bodies, and (2) is independent of the area of contact between them, within wide limits of pressure. If one of the two bodies rests on the other and if the surfaces of contact are plane and horizontal, the pressure is the weight of the upper body, and the maximum static friction is the force applied horizontally to the upper body that will just produce motion between them. If additional weights are placed on the upper body, the pressure between the surfaces will be increased, and the friction will be increased in the same proportions. See "A Textbook of Physics," edited by A Wilmer Duff, 3rd edition, P. Blakiston's Son & Co., Philadelphia, 1931, sec. 126, pages 93-94.

Thus, referring to Fig. 4 herein, the maximum static friction between section 18*d* and section 18*c* acting to prevent relative movement between them is proportioned to the weight of section 18*d* (considered as including the weight of the back-rest 7 and the weight of any letters stacked thereagainst); that between sections 18*c* and 18*b* is proportioned to the aforesaid weight of 18*d* plus the weight of 18*c* (and any letters stacked thereon after it has been partly displaced) and thus is greater than that between 18*d* and 18*c*; that between 18*b* and 18*a* is correspondingly still greater; and that between section 18*a* and the support bar 12 is greatest of all. Accordingly, in the form shown, the members 18*d*, 18*c*, 18*b*, 18*a*, from outermost to innermost, are retained against movement by progressively greater forces, whereby each moves to its full extension before movement of the next commences, so that relative longitudinal movement between the letters and the respective telescopic sections upon which they are stacked is substantially eliminated.

In other words, the construction last described provides a longitudinally movable platform or floor for the stack of letters as it is built up, so that friction due to the movement of the lower edges of a large number of letters in a stack in contact with and moving over a fixed floor surface in the trough is substantially eliminated by the absence of relative movement between the letter edges and floor surface. Thus, the pressure or load imposed by the inertia of the stack on the upper part of the face of the feeding helix is very substantially reduced. Furthermore, any tendency for the letters of the stack to lean over out of the vertical due to drag upon the lower edges thereof in opposition to the pressure of the helix face upon the upper parts of the letters, as the stack increases in size, is also virtually eliminated.

Reduction in the pressure between the face of the feeding helix and stack of letters will also reduce the tendency for the helix to twist the letters out of the stack.

In a modified form of the construction of Figures 1 to 5 and shown in Figs. 6 and 7, a reciprocating hook ended bar or rod 22 is disposed beneath the level of the trough platform 8 so as to extend longitudinally thereof and is coupled to a driving motor 23 by a driving crank or other suitable means for periodically reciprocating the bar or rod in a direction parallel with the length of the trough and at right angles to the back rest 7. Although not shown in Figures 6 and 7, it will be understood that the trough floor or platform 8 comprises telescopic floor sections as shown in Figures 3 and 4.

The hook end 22*a* of the member 22 is positioned just clear of the out-put end of the feeding helix 6, so that in one direction of its movement, i. e., towards the back rest 7, the hook end engages the foremost letter of the stack thereby positively drawing the stack away from the helix. The completion of the movement of the hooked member towards the back rest will draw the stack of letters and back rest away from the feeding helix by a distance approximately equal to the thickness of the several letters which have been fed from the helix since the preceding letter-drawing stroke of the hooked member. On the reverse or idle stroke of the reciprocating member 22 its hook end does not impede the feeding of

5

letters fed from the helix 6 the inclination of the upper part of the end 22a of the hooked member 22 being such that upon the reverse or idle stroke of the member, the hook end slides beneath the edge of any letter which may be fed from the helix during the idle stroke of the hooked member.

In view of the positive movement imparted to the stack and back rest by the reciprocating letter drawing device 22, it is desirable to provide a light, yielding brake or detent control to obviate the possibility of producing a very loose stack with a tendency for the foremost letters thereof to lean forwards in an undesirable manner. Accordingly, the guide rod 16, which slidably supports the back rest 7 in the manner above described, is provided with a toothed rack 24 which is engaged by a spring-loaded detent roller 25. In the construction shown in Figs. 6 and 7, the guide rod or bar is made of angle section strip disposed to form a runway with a lower horizontal flange and an upper vertical flange both of which are engaged by flat faced runner wheels or rollers 15a with plain peripheral edges. The upper longitudinal edge of the vertical flange of the angle section guide member is provided with V-notches and V-shaped teeth forming the rack 24, while the detent roller 25 has a V-section groove around its peripheral edge to facilitate the positive engagement of the detent roller in the V-notches of the rack.

The back rest is thus lightly and releasably held in position by the engagement of the detent roller in a V-notch of the rack, but as the pressure upon the back rest is increased by the stacking of the letters and positive displacement of the letter stack as above described, the detent roller is displaced against the action of its loading spring 26 to ride up over a V-tooth of the toothed rack and engage in the next V-notch and so on. A controlled step-by-step retreating movement of the back rest as the stack of letters grows in length is thus achieved and the compactness of the stack is, to some extent, determined by the strength of the detent loading spring 26. It will be understood that the application of the brake control to the backrest may also be employed in the construction of Figures 1 and 2, i. e. without the reciprocating member 22.

As an alternative to the stack-displacing member 22, a driving connection may be provided between the feed rollers 3 and 4 and the back rest 7 so that a positive drive of the latter away from the helix and related to the rate of letter feed is effected.

We claim:

1. In a letter stacking apparatus, a stacking trough having a telescopic letter supporting floor comprising a series of freely interlocking elongated hollow sections supported for relative sliding movement longitudinally of the trough, a backrest supported on the outermost of the said interesting sections and movable therewith, a positively driven feeding helix disposed adjacent one end of said floor and adapted to feed letters one by one into the said trough so as to rest edgewise on said telescopic sections and stack face to face against the said backrest thereby to displace the said backrest and telescopic sections longitudinally of the trough in a direction away from the helix, and means supporting said series of interesting sections for said longitudinal movement from a collapsed position in which the sections are substantially fully superposed one upon the other with said backrest positioned immediately adjacent the delivery end of the helix, to a fully extended position in which the said sections extend successively longitudinally of the trough with the innermost section lying adjacent the delivery end of the helix whereby relative longitudinal movement between the letters and the respective telescopic section upon which they are stacked is substantially eliminated.

2. In a letter stacking apparatus, a stacking trough having a telescopic letter supporting floor comprising a series of freely interesting elongated hollow sections supported for relative sliding movement longitudinally of

6

the trough, a backrest supported on the outermost of the said interesting sections and movable therewith, a positively driven feeding helix disposed adjacent one end of said floor and adapted to feed letters one by one into the said trough so as to rest edgewise on said telescopic sections and stack face to face against the said backrest thereby to displace the said backrest and telescopic sections longitudinally of the trough in a direction away from the helix and a rigid guide rod extending longitudinally of the trough in engagement with the innermost of said telescopic sections and supporting the said series of interesting sections for said longitudinal movement from a collapsed position in which the sections are substantially fully superposed one upon the other with said back rest positioned immediately adjacent the delivery end of the helix, to a fully extended position in which the said sections extend successively longitudinally of the trough with the innermost section lying adjacent the delivery end of the helix whereby relative longitudinal movement between the letters and the respective telescopic section upon which they are stacked is substantially eliminated.

3. In a letter stacking apparatus, a stacking trough having a telescopic floor comprising a plurality of rigid guideways extending in spaced parallel relation longitudinally of the said trough, each of said guideways supporting a series of freely interesting hollow telescopic sections slidable longitudinally with respect thereto, a backrest extending transversely of the trough and supported upon the outermost section of each of said series of sections for movement therewith, a positively driven feeding helix disposed adjacent one end of said floor and adapted to feed letters one by one on to the said floor so as to rest edgewise on the said telescopic sections and stack face to face against the said backrest thereby to displace the said backrest and the plurality of series of telescopic sections longitudinally of the trough in a direction away from said one end thereof, each of the said rigid guideways supporting the corresponding series of interesting sections for sliding movement longitudinally thereof from a collapsed position in which the sections are substantially fully superposed one upon the other with the said backrest positioned immediately adjacent the delivery end of the helix, to an extended position in which the sections extend successively longitudinally of the guideway with the innermost section lying adjacent the said delivery end of the helix whereby relative movement of the letters longitudinally with respect to the telescopic sections upon which they are stacked is substantially eliminated.

4. In a letter stacking apparatus, a stacking trough having a telescopic letter supporting floor comprising a series of freely interesting elongated hollow sections supported for relative sliding movement longitudinally of the trough, a backrest supported on the outermost of the said interesting sections and movable therewith, a positively driven feeding helix disposed adjacent one end of said floor and adapted to feed letters one by one into the said trough so as to rest edgewise on said telescopic sections and stack face to face against the said backrest thereby to displace the said backrest and telescopic sections longitudinally of the trough in a direction away from the helix, and means supporting said series of interesting sections for said longitudinal movement from a collapsed position in which the sections are substantially fully superposed one upon the other with said backrest positioned immediately adjacent the delivery end of the helix, to a fully extended position in which the said sections extend successively longitudinally of the trough with the innermost section lying adjacent the delivery end of the helix whereby relative longitudinal movement between the letters and the respective telescopic section upon which they are stacked is substantially eliminated, and means separate from the feeding helix for positively urging the growing stack of letters in the direction of movement of the stack thereby to assist the said move-

ment of the backrest and telescopic sections away from the helix.

5. In a letter stacking apparatus, a stacking trough having a telescopic letter supporting floor comprising a series of freely interesting elongated hollow sections supported for relative sliding movement longitudinally of the trough, a backrest supported on the outermost of the said interesting sections and movable therewith, a positively driven feeding helix disposed adjacent one end of said floor and adapted to feed letters one by one into the said trough so as to rest edgewise on said telescopic sections and stack face to face against the said backrest thereby to displace the said backrest and telescopic sections longitudinally of the trough in a direction away from the helix and a rigid guide rod extending longitudinally of the trough in engagement with the innermost of said telescopic sections and supporting the said series of interesting sections for said longitudinal movement from a collapsed position in which the sections are substantially fully superposed one upon the other with said backrest positioned immediately adjacent the delivery end of the helix, to a fully extended position in which the said sections extend successively longitudinally of the trough with the innermost section lying adjacent the delivery end of the helix whereby relative longitudinal movement between the letters and the respective telescopic section upon which they are stacked is substantially eliminated, a stack-displacing member separate from said feeding helix, and means for periodically moving said stack-displacing member longitudinally of the trough into and out of engagement with the last fed letter of the stack, thereby to urge the said stack and the backrest in the direction of travel of the growing stack so as to assist the said movement of the backrest and telescopic sections away from the feeding helix.

6. In a letter stacking apparatus, a stacking trough having a telescopic floor comprising a plurality of rigid guideways extending in spaced parallel relation longitudinally of the said trough, each of said guideways supporting a series of freely interesting hollow telescopic sections slidable longitudinally with respect thereto, a backrest extending transversely of the trough and supported upon the outermost section of each of said series of sections for movement therewith, a positively driven feeding helix disposed adjacent one end of said floor and adapted to feed letters one by one on to the said floor so as to rest edgewise on the said telescopic sections and stack face to face against the said backrest thereby to displace the said backrest and the plurality of series of telescopic sections longitudinally of the trough in a direction away from said one end thereof, each of the said rigid guideways supporting the corresponding series of interesting sections for sliding movement longitudinally thereof from a collapsed position in which the sections are

substantially fully superposed one upon the other with the said backrest positioned immediately adjacent the delivery end of the helix, to an extended position in which the sections extend successively longitudinally of the guideway with the innermost section lying adjacent the said delivery end of the helix whereby relative movement of the letters longitudinally with respect to the telescopic sections upon which they are stacked is substantially eliminated and a stack-displacing means comprising a hook-ended member disposed beneath the trough floor for reciprocal movement longitudinally thereof with the hook end of the member extending upwardly between two adjacent of said parallel disposed guideways so that in moving in the direction away from the said one end of the floor, the hook end engages the last fed letter of the stack to urge the stack and the backrest in said direction away from the helix, and in moving in the opposite direction the said hook end passes freely beneath the letters passing from the helix to the stack, and driving means connected to said member for effecting said reciprocal movement thereof.

7. Apparatus as claimed in claim 6 provided with means adapted to retard and control the movement of the backrest by the action of said stack displacing means and comprising a stationary toothed rack extending longitudinally of the trough and a pivotally mounted yieldingly loaded detent member supported by the backrest and arranged to track along the stationary toothed rack so as releasably to position the backrest relative to the said toothed rack while yielding to pressure applied to the backrest by said stack displacing means thereby to permit controlled step-by-step movement of the backrest and the letter stack supported thereby.

8. Apparatus as claimed in claim 6 including inversely rotating co-operating rollers adapted to feed letters one at a time to the feeding helix, and a driving connection between said inversely rotating rollers and the driving means of said reciprocable hook-ended member, whereby the said movement of the backrest under the action of said hook-ended member is effected in accordance with the rate of feed of the letters from the inversely rotating rollers to the helix.

#### References Cited in the file of this patent

##### UNITED STATES PATENTS

625,861	Vail	May 30, 1899
895,833	Aungst	Aug. 11, 1908
902,668	Madigan	Nov. 3, 1908
1,035,716	Lynch	Aug. 13, 1912
1,576,243	Mentges	Mar. 9, 1926
1,603,294	Reiser	Oct. 19, 1926
2,095,063	Graf	Oct. 5, 1937
2,529,031	Lewis	Nov. 7, 1950