

(19) World Intellectual Property Organization  
International Bureau



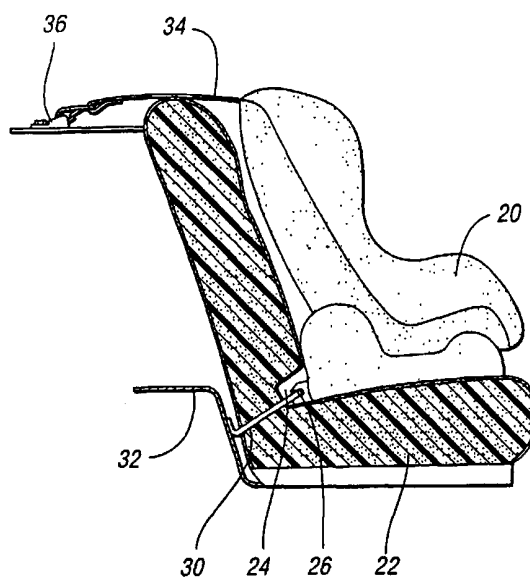
(43) International Publication Date  
25 May 2001 (25.05.2001)

PCT

(10) International Publication Number  
**WO 01/36226 A2**

- (51) International Patent Classification<sup>7</sup>: **B60N 2/00** Court, Novi, MI 48377 (US). **SCHULTE, Steven, A.**; 21955 Meridian Lane, Novi, MI 48375 (US). **SEBBY, Mark, S.**; 5926 Fonda Lake Drive, Brighton, MI 48116 (US).
- (21) International Application Number: PCT/US00/42207
- (22) International Filing Date:  
16 November 2000 (16.11.2000) (74) Agents: **HARRINGTON, Donald, J.** et al.; Brooks & Kushman, 1000 Town Center, Twenty-Second Floor, Southfield, MI 48075 (US).
- (25) Filing Language: English
- (26) Publication Language: English (84) Designated States (regional): European patent (AT, BE, CH, CY, DE, DK, ES, FI, FR, GB, GR, IE, IT, LU, MC, NL, PT, SE, TR).
- (30) Priority Data:  
60/165,879 16 November 1999 (16.11.1999) US **Published:**  
— Without international search report and to be republished upon receipt of that report.
- (71) Applicant: **LEAR CORPORATION** [US/US]; 21557 Telegraph Road, Southfield, MI 48034 (US).
- (72) Inventors: **HICKS, Thomas, S.**; 14249 Ingram, Livonia, MI 48154 (US). **SABO, Dianna, L.**; 29827 Warwick
- For two-letter codes and other abbreviations, refer to the "Guidance Notes on Codes and Abbreviations" appearing at the beginning of each regular issue of the PCT Gazette.*

(54) Title: ANCHORAGE SYSTEM FOR AUTOMOTIVE VEHICLE SEATS



(57) Abstract: A universal restraint system for securing objects on the seat portion of a forward-facing seat assembly in an automotive vehicle and for securing objects on the floor of the cargo area of a utility vehicle.



WO 01/36226 A2

## ANCHORAGE SYSTEM FOR AUTOMOTIVE VEHICLE SEATS

### TECHNICAL FIELD

The invention relates to restraints for securing articles within a vehicle passenger compartment.

5

### BACKGROUND ART

It is common practice in the operation of contemporary automotive vehicles having a forward-facing rear seat to place small cargo or personal items on the seat portion of the rearward seat assembly. Child seat restraints also are adapted to be supported on the upper surface of the seat portion of a forwardly facing seat assembly. The child seat restraint typically is secured in place by a passenger seat belt assembly. It is common practice also to carry small cargo in the cargo area at the rear of a seat back portion of a rear-mounted seat assembly in a utility vehicle. Cargo placed in the cargo area usually is unrestrained except for the restraint that is provided by the upright seat back portion.

15

International standards have been proposed for designing seat anchorages that will prevent movement of articles stored on a forwardly facing seat assembly when they are subjected to inertia loads due to rapid deceleration of a vehicle. In the case of a child seat restraint anchorage system, the anchorages to which the proposed standards apply may supplement the restraints that normally would be provided by a passenger seat belt system.

20

### DISCLOSURE OF INVENTION

The anchorage system of the invention comprises rigid anchor rings located adjacent the pivot axis for the upright seat back portion of a forwardly facing automotive seat assembly. The pivot axis is located at the rearward margin of the lower seat portion that supports the vehicle passenger. The anchor rings may be

25

secured to the seat frame in the case of a forwardly facing rear seat assembly. The inertia loads that would be transmitted to the anchor rings are transferred through the seat frame to stationary structural elements of the vehicle passenger compartment. In the case of anchor rings for the cargo area of a passenger vehicle, the floor structure of the cargo area receives the inertia forces transmitted by the anchor rings. This prevents cargo in the cargo area from being dislodged due to inertia forces, thereby enhancing occupant safety by preventing cargo objects from becoming dislodged and thrown about the interior of the passenger compartment.

The anchors for the rear forwardly facing seat assembly may include two lower anchorage systems, including an anchor ring situated at the rear of the passenger supporting seat portion. The location of the anchor rings in the floor structure of a cargo area for a passenger vehicle is determined by the specific design of the cargo area.

The load path for the anchor rings typically is in a for-and-aft direction, but the rings are capable also of accommodating lateral loading. Provision is made for improving the appearance of the exposed portions of the anchor assembly.

A child seat may be restrained by the anchors when it is supported on a front or rear passenger seat. This may complement the restraint of a conventional passenger seat belt.

A pet carrier may be adapted to be used with the anchor rings when the carrier is supported on the seat portion of the forwardly facing rear seat assembly. The pet carrier includes reinforcing straps on its walls, which transmit inertia loads on the carrier, and the pet within the carrier, to the anchor rings. Briefcases, large purses, lap-top computers, etc., also can be restrained in this fashion if they are supported on a platform assembly, which in turn is adapted to be anchored to the anchor rings.

## BRIEF DESCRIPTION OF DRAWINGS

FIGURE 1 is a front elevational view of a forwardly facing rear seat assembly for a passenger vehicle;

5                   FIGURE 2 is a side view of the seat assembly on which is positioned a pet carrier;

FIGURE 3 is a schematic side elevation view, partly in cross-section, showing a child restraint seat supported on the seat portion of a forwardly mounting rear seat assembly for an automotive vehicle;

10                   FIGURE 3a is a detailed cross-sectional view of an anchor ring for anchoring the child restraint seat of Figure 3;

FIGURE 4 is a full rear seat assembly for supporting two passengers wherein the anchor rings are located in laterally spaced pairs;

15                   FIGURE 4a is an enlarged cross-sectional view of an anchor ring seen in Figure 4;

FIGURES 4b and 4c show the relative lateral positions of anchor rings, illustrated partially, for the forwardly facing seat assembly seen in Figure 4;

FIGURE 5 is an isometric view of a pet carrier shown assembled on the lower seat portion of a rear seat assembly;

20                   FIGURE 5a is a schematic view of reinforcing straps for the pet carrier of Figure 5;

FIGURE 6 shows a portable cargo tray or platform that can be supported on the lower seat portion of a passenger vehicle and restrained using the anchorage of the invention;

FIGURE 6a is an isometric view of a modification of the cargo platform of Figure 6;

FIGURE 6b shows a cargo platform leveling mechanism for use with the platforms of Figures 6 and 6a;

5                   FIGURE 7 shows a cargo-carrying area of a sport utility vehicle wherein the anchorage of the invention is used to support a cargo platform that carries items such as the illustrated pet carrier or an oversized cooler;

FIGURE 8 is an isometric view of a bicycle secured within the cargo-carrying area of a sport utility vehicle.

## 10                   **BEST MODE FOR CARRYING OUT THE INVENTION**

Figure 1 shows a lower seat portion 10 for a seat assembly of an automotive vehicle. The upright seat back portion 12 is hinged to the rearward margin of the seat portion 10 in known fashion. The hinge axis of the upright seat back portion 12 determines the approximate location of a pair of anchor rings 14  
15                   situated in laterally spaced relationship, one with respect to the other, at the rearward margin of the lower seat portion.

Figure 2 is an example of an article that can be restrained by the anchor rings 14. In the case of Figure 2, the article is a pet carrier 16 that is provided with a restraining strap of the kind that will be described subsequently with  
20                   respect to Figure 5.

Figure 3 is a schematic representation, partly in cross-section, of a seat assembly on which is supported a child restraint seat 20. The lower seat portion 22 of the seat assembly of Figure 3 has a recessed area 24 in which is positioned an anchor ring 26. One anchor ring is situated on each lateral side of the child restraint  
25                   seat 20. A releasable attachment 28, seen in Figure 3a, secures the ring 26 to the child restraint seat 20. As seen in Figure 3, the ring 26 includes an extension 30,

which is anchored at its rearward end to the floor pan structure 32 of a vehicle passenger compartment.

5 Located at the upper end of the child restraint seat 20 is a tether strap 34 secured at its right end to the structural back portion of the child restraint seat 20. The left end of the tether strap is secured to an anchor ring 36 by a hook attachment. The anchor ring 36 is secured to a structural member of the passenger compartment.

10 As seen in Figures 4, 4b and 4c, there are two anchor rings for each seat back of the forwardly facing seat assembly. The spacing 37 between the anchor rings may be about 280 mm. The length of the transverse portion 38 of each anchor ring 40 may be about 25 mm, as seen in Figure 4c at 38.

15 As seen in Figure 4a, each anchor ring 40 can be positioned in a recess in the lower region of the upright seat back portion. A suitable trim piece or liner 42 can be used to improve the aesthetic effect of the exposed portion of the anchor ring 40 and to act as a guide for the attachment.

20 Seen in Figure 5 is a pet carrier 44 which can be mounted on the lower seat portion 46 in a manner similar to the mounting of the pet carrier 16 of Figure 2. In the case of the pet carrier of Figure 5, reinforcing straps 48 and 50 have releasable attachments 52 to permit their securement to the anchor rings shown at 54 and 56.

25 As seen in Figure 5a, the reinforcing straps are secured to first and second reinforcing strips 54 and 56, respectively. These strips are secured to a belt 58, which encircles the carrier. The strips 54 and 56 are secured at securing points, one of which is shown at 60, to provide a unitary reinforcing structure. The top of the carrier on one side can be formed with a zipper opening, as seen in Figure 5, for purposes of ingress and egress of a pet.

Figure 6 shows a platform assembly 62, which is supported on the lower seat portion 64 of a forwardly facing automotive seat assembly. The rearward

margin of the platform 62 is provided with attachment devices 66, which readily can be secured to transversely positioned anchorage rings 68 and 70 located at the rearward margin of the lower seat portion 64. They are secured, as shown in Figure 3, to the vehicle floor plan structure.

5                    In a variation of the design of Figure 6, a leveling foot 72, which has an upright plate 74, is provided with a set screw 76 located in a vertical slot 78. The set screw 76 is threadably received in a rearward baffle plate 80 on the platform assembly. The platform assembly can be leveled by adjusting set screw 76 to raise or lower the baffle plate 80.

10                    The platform assembly 62 comprises a rearward plate 82, which is hinged to the horizontal surface portion 84 of the platform assembly 62. A forward plate 86 is secured to the forward edge of the horizontal surface portion 84. A flexible net 88 can be provided at the forward edge of the platform assembly for securing articles in place on the platform portion 84. Bungee cords can be used also  
15 as shown at 90 and 92 at each of the lateral sides of the platform assembly to secure articles in place.

                      A sub-platform 94 is slidably positioned below the platform portion 84. The sub-platform 94 can be adjusted laterally to expand the useful load-supporting surface on the platform assembly. An end wall 96 is located at the  
20 extended end of the sub-platform 94. Articles supported on the platform assembly can be secured by bungee cords, one of which is shown at 98.

                      At the opposite lateral side of the platform assembly 62, there is an end wall 100 situated on a secondary sub-platform corresponding to the sub-platform 94. These sub-platforms can be moved simultaneously to an extended lateral  
25 position or they can be individually adjusted as seen in Figure 6.

                      Figure 6a shows a modified form of platform assembly. It is identified by reference character 102. As in the case of the embodiment of Figure

6, the embodiment of Figure 6a includes side walls 104 and 106 on the lateral sides of a horizontal platform portion 108.

A platform cover 110 is hinged at its lower edge to the rearward edge of the horizontal platform portion 108. When the platform assembly 102 is not in use, the cover 110 can be moved on its end axis to a closed position. If desired, a flexible retainer net 112 may be enclosed by the platform assembly and moved to the position shown in Figure 6a when the cover 110 is moved on its hinge axis to the open position.

Figure 7 shows anchorages at 114, 116, 118 and 120 located in the cargo compartment of a vehicle, such as a sport utility vehicle. The anchors 114-120 are longitudinally spaced. Corresponding anchors, not shown, are located transversely with respect to the anchors 114-120. Platform assemblies 62' and 62'', which correspond to the platform assembly 62 of Figure 6, can be secured to the anchors 114-120. Attachments, such as those shown at 66 and 70 in Figure 6b, are used to secure articles, such as an animal carrier 122 or an oversized cooler 124, securely in place on their respective platform assemblies. Bungee cords 128 and 129 may be used for securing the articles in place on their respective platform assemblies.

Figure 8 shows an anchorage for sports equipment, such as a bicycle 130 and snow skis 132. An anchor bar 134 is secured to the load carrying platform 136. Latches 138 secure the bar to the platform 136. A bicycle fork is secured at its lower end to the bar 134 by a bike fork attachment 144. Anchor rings 140 secure the bar 134 to the platform 136. A bicycle wheel 146 is secured to a supporting pedestal 148 that is attached to the bar 134. Accessory clamps 150 carried by the bar 134 hold the snow skis 132 securely in place.

In Figure 8, the seat back for the rear seat assembly is folded forward. A seat back stabilizer 152 is secured to the seat back frame. The rear wheel of the bicycle 130 is restrained by the seat back stabilizer 152.



Although preferred embodiments of the invention have been disclosed, modifications may be made by persons skilled in the art without departing from the scope of the invention. All such modifications, and equivalents thereof, are intended to be covered by the following claims.

**WHAT IS CLAIMED IS:**

1. An anchorage system for a passenger compartment of an automotive vehicle, the passenger compartment comprising a structural floor supporting passenger seat structures;

5 anchorage rings secured to the structural floor, the passenger compartment being adapted to transport articles; and

a releasable attachment for securing the articles to the anchorage rings whereby inertia loads on the articles during movement of the vehicle are transmitted through the anchorage rings to the structural floor.

10 2. An anchorage system for a passenger compartment of an automotive vehicle, the passenger compartment enclosing passenger supporting seats;

at least one of the seats having a forward-facing passenger supporting cushion portion and a seat back, a seat frame;

15 the passenger compartment having a structural floor, the seat frame being connected to the structural floor;

the seat back being pivotally connected to the seat frame to accommodate forward tilting motion of the seat back relative to the seat cushion portion;

20 at least one anchor ring located adjacent a pivot axis of the seat back and connected to the seat frame, the seat cushion portion supporting one or more articles; and

25 a mechanical releasable connection between the articles and the anchor ring whereby inertia forces on the articles during movement of the vehicle are transmitted to the structural floor as the articles remain securely in place on the cushion.

3. The anchorage system set forth in claim 2 wherein an article supported on the cushion portion is a child seat assembly, the child seat assembly having a mechanical attachment to one or more of the anchor rings.

4. The anchorage system set forth in claim 2 wherein an article supported by the seat cushion portion is a pet carrier, the pet carrier having a reinforcing strap at a lower margin thereof, and a releasable fastener at one end of the reinforcing strap for effecting a secure attachment with an anchor ring.

5 5. The anchorage system set forth in claim 1 wherein the passenger compartment includes a cargo-carrying portion located rearward of the passenger seat structures;

an anchor bar in the cargo-carrying portion;

10 anchor rings secured to the structural floor and extending upward from the floor;

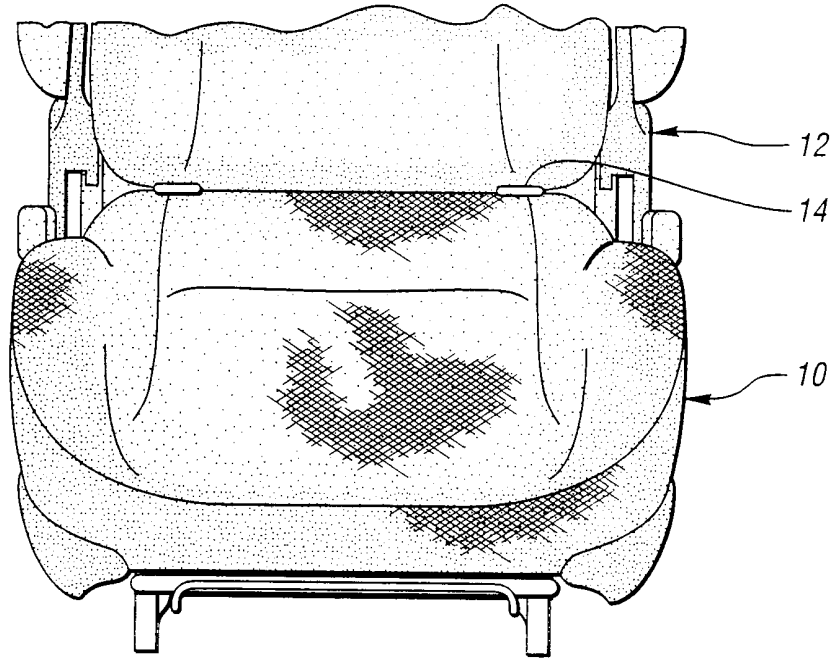
the anchor bar being secured to the anchor rings; and

clamp members attached to the anchor bar for securing articles carried in the cargo-carrying portion to the anchor bar whereby the articles are secured in place as inertia forces are on the articles during movement of the vehicle.

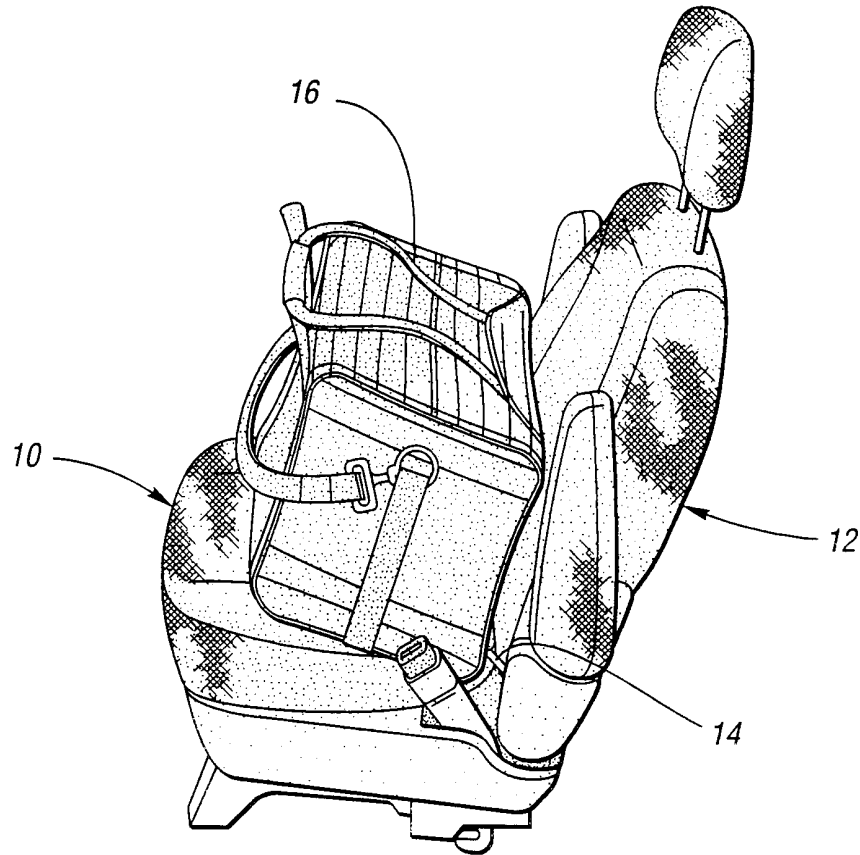
15 6. The anchorage system set forth in claim 1 wherein the passenger compartment includes a cargo-carrying portion located rearward of the passenger seat structure;

anchor rings secured to the structural floor at spaced locations in a pattern extending in a fore-and-aft direction and extending upward from the floor;

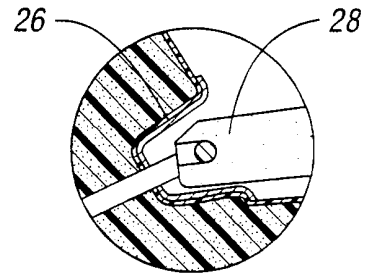
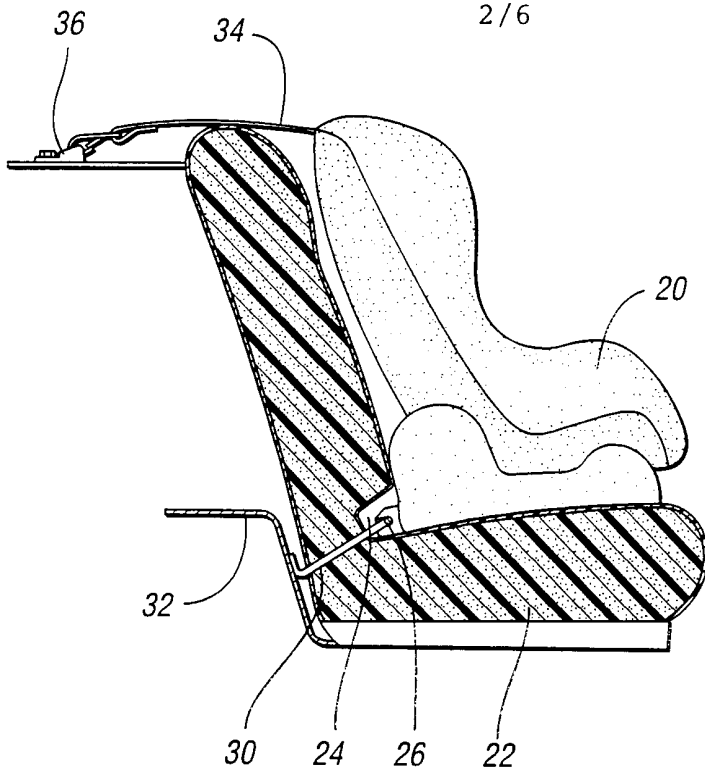
20 the articles including a platform assembly with attachment elements for securing the platform assembly to the anchor rings whereby inertia forces acting on the platform assembly during movement of the vehicle are transmitted directly to the structural floor.



*Fig. 1*

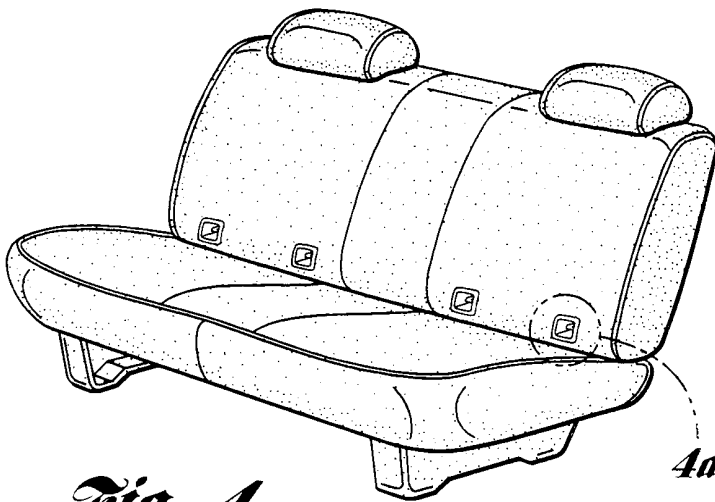


*Fig. 2*

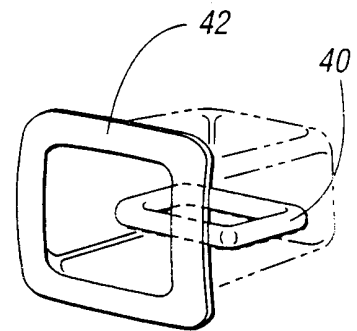


*Fig. 3a*

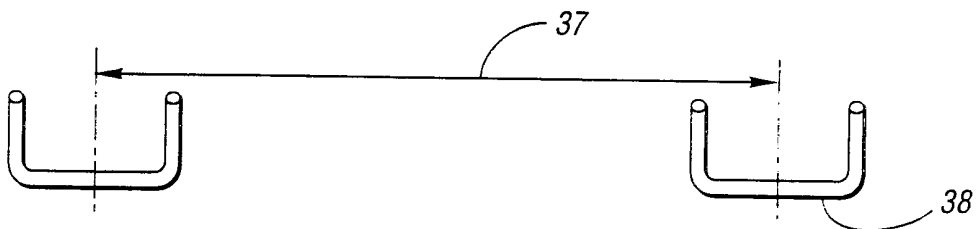
*Fig. 3*



*Fig. 4*

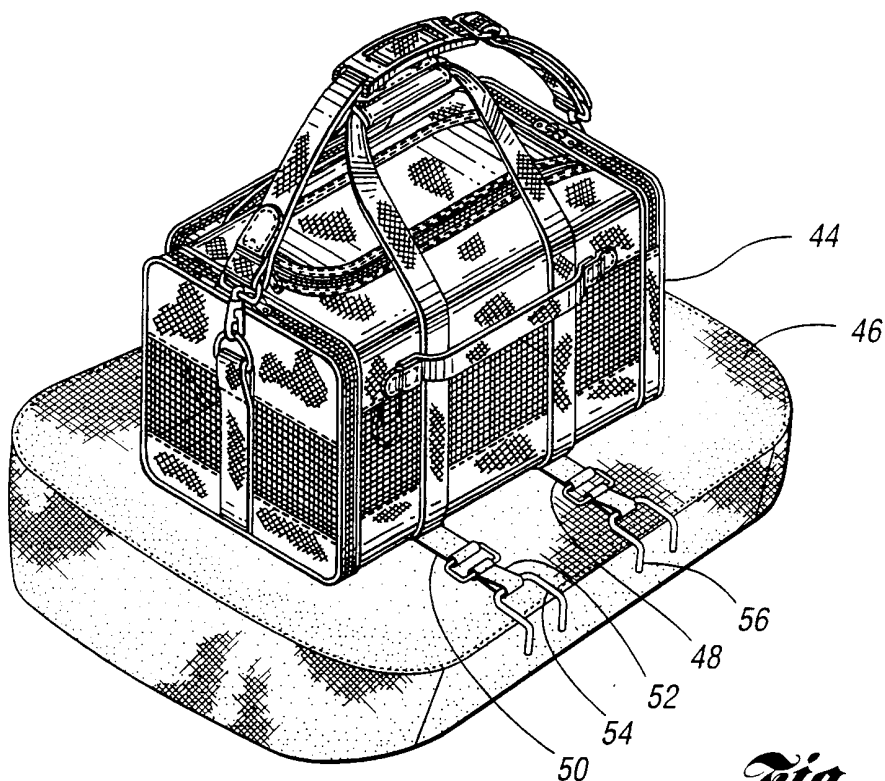


*Fig. 4a*

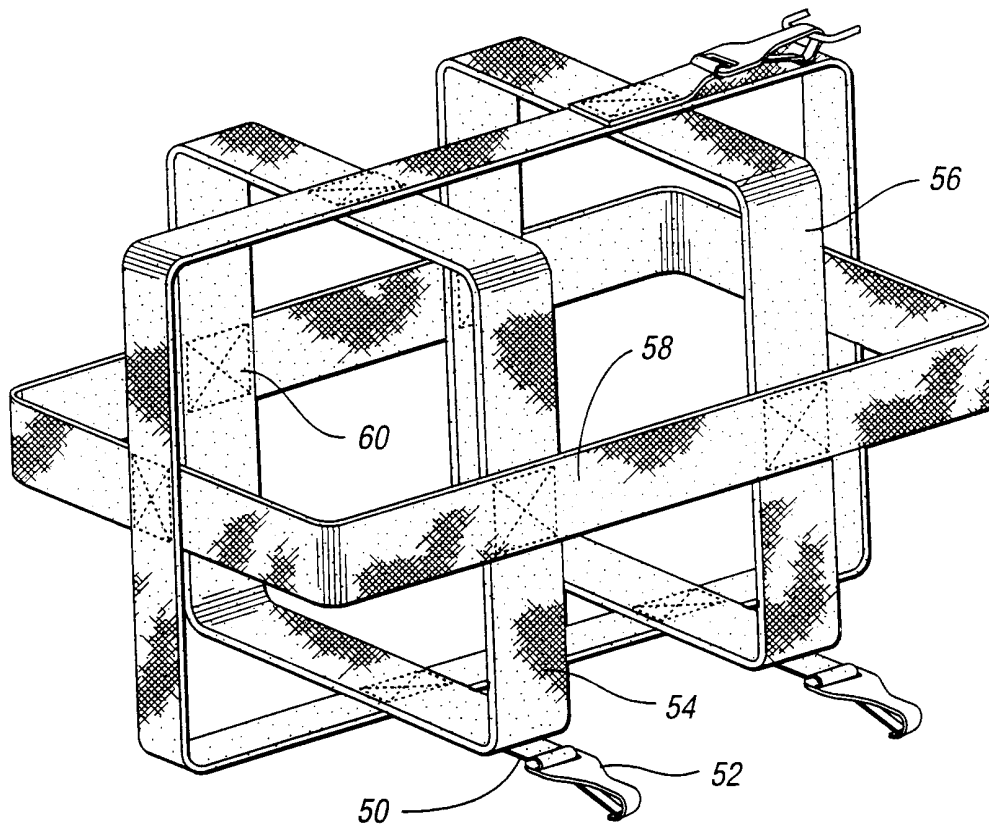


*Fig. 4b*

*Fig. 4c*



*Fig. 5*



*Fig. 5a*



