

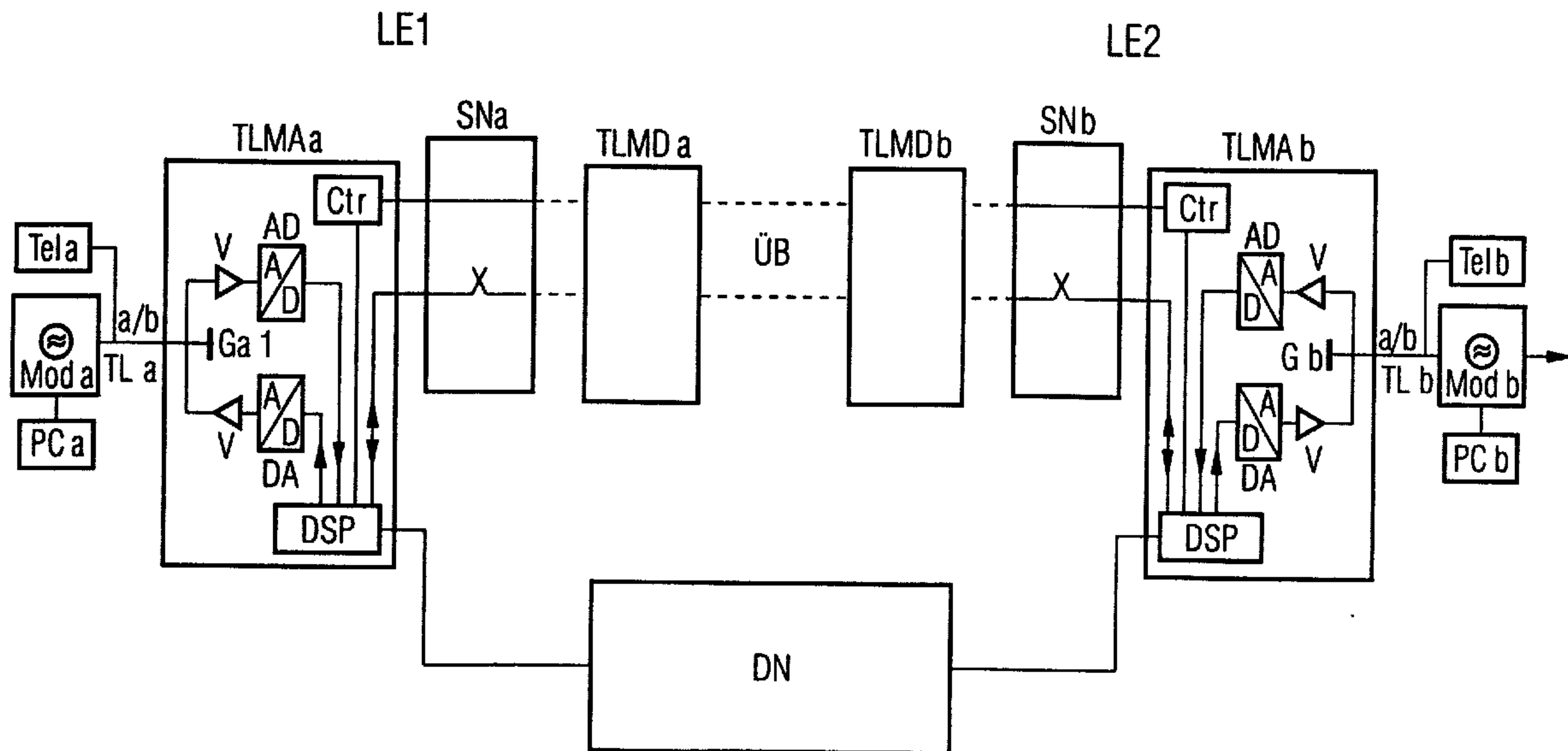

(86) Date de dépôt PCT/PCT Filing Date: 1999/01/14
 (87) Date publication PCT/PCT Publication Date: 1999/08/12
 (85) Entrée phase nationale/National Entry: 2001/07/30
 (86) N° demande PCT/PCT Application No.: DE 99/00059
 (87) N° publication PCT/PCT Publication No.: WO 99/40685
 (30) Priorité/Priority: 1998/02/05 (198 04 591.3) DE

(51) Cl.Int.⁶/Int.Cl.⁶ H04M 11/06, H04M 3/00
 (71) Demandeur/Applicant:
SIEMENS AKTIENGESELLSCHAFT, DE
 (72) Inventeurs/Inventors:
RUDOLF, HANS-WERNER, DE;
KUNISCH, PAUL, DE
 (74) Agent: FETHERSTONHAUGH & CO.

(54) Titre : PROCEDE POUR LE TRAITEMENT DE SIGNAUX TELEPHONIQUES DELIVRES PAR UN TERMINAL TELEPHONIQUE ANALOGIQUE
 (54) Title: METHOD FOR PROCESSING TELEPHONE SIGNALS DELIVERED BY AN ANALOG TELEPHONE TERMINAL



(57) Abrégé/Abstract:

In transmissions via analog subscriber lines (TLa, TLb), data undergoes a processing that differs from the processing used for normal modem links or for transmitted analog voice signals, namely an A/D conversion at higher scanning rates and with a coding according to a linear characteristic curve.

Abstract

In the context of transmission via analog subscriber lines (TLa, TLb), unlike in the case of conventional modem connections, the data are subjected to different handling than the likewise transmitted analog voice signals, to be specific are subjected to an A/D conversion at a higher sampling rate and to a coding operation according to a linear characteristic.

10

Figs.

GR 98 P 1128

Method of handling telephone signals supplied by an analog telephone set and data supplied by a data terminal

5

The invention relates to a method according to the precharacterizing clause of patent claim 1.

It accordingly concerns a situation in which an analog subscriber line of a telephone switching system is shared by an analog telephone set and a data terminal, the connection of the data terminal to the subscriber line taking place via a modem. The modem (modulator/demodulator) is a data transmission device which serves the purpose of converting the digital signals supplied by the data terminal into transmissionally advantageous line signals which correspond to the electrical conditions of analog telephone connections or perform a conversion of such signals back into digital signals. In this context, the data are modulated onto carrier signals, different modulation methods being used.

15
20

An example of such a type of connected data terminal which comes into consideration is a personal computer (PC).

In the previously known data transmissions of data terminals connected in this way via the telephone network, so-called modem transmissions, the data undergo the same handling in the subscriber line units of the telephone switching system as the voice signals, to be specific a band limitation to less than 4 kHz, an analog/digital conversion and a coding according to a nonlinear characteristic (A-law or μ -law), in order to reduce the bit transmission rate according to the limited available transmission bandwidth.

25
30

Such handling operations have a restrictive effect on the data transmission, in particular if large amounts of data are to be transmitted, as is the case with modem connections which lead via the modem pool of a network provider to the Internet.

5

The object of the invention is therefore to specify for the preconditions mentioned a method of handling telephone signals and data supplied by data terminals in the subscriber line circuit which leads to more favorable conditions, in particular for the data transmission. This object is achieved by a method which has the features of the characterizing clause of patent claim 1.

Accordingly, during the required analog/digital conversion in the subscriber line circuit, at least the data supplied by the data terminal are subjected to a sampling operation at a sampling rate which lies above the sampling rate required for the telephone information and/or the sampling values representing the data supplied by the data terminal undergo a coding operation according to a linear characteristic. The data originating from the data terminal and handled in such a way are fed directly to a data transmission network.

Consequently, on the one hand it is accepted not to subject the data originating from the data terminal to the same restrictions as the signals originating from the analog telephone set, primarily including the bit rate reduction by application of a nonlinear characteristic, on the other hand a sampling rate corresponding to the needs of the data transmission is used, without regard to the limited transmission band of the telephone transmission paths, since there is no need to regard bandwidth limits on account of the direct transfer of the data via a data transmission network. The two measures in the form of avoiding nonlinear coding and

working with a higher sampling rate than is intended for telephone information can in each case be used individually or else in combination.

5 Further refinements of the invention are characterized in subclaims.

According to a first refinement of the method according to the invention, for the transmission on the subscriber line, the
10 data signals supplied by the data terminals are modulated onto a carrier signal, the frequency of which lies above the frequency band authorized for the transmission of telephone signals. This dispels the restrictions which have previously
15 limit maintained with regard to the voice band limitation.

A further refinement of the invention takes the form of a subscriber line circuit which is designed with regard to the implementation of the method according to the invention and in
20 this context comprises an analog/digital converter and digital/analog converter, used both for the voice signals and for the data signals, and a signal processor which is connected on the digital side of said converter and represents the digital interface with respect to the switching matrix of
25 the telephone exchange on the one hand and the data network on the other hand.

The invention is explained in more detail below on the basis of an exemplary embodiment with reference to a figure.

30

The figure shows to the extent required for explaining the invention the component parts of two telephone exchanges LE1 and LE2, between which a transmission link UB exists, as well as a data transmission network DN as a block.

The modem communication of a data terminal which is connected to the telephone exchange LE1 with a data terminal which is connected to the telephone exchange LE2 is explained. These data terminals may be, for example, the personal computers PCa and PCb. These are connected in each case via a modem Moda and Modb, respectively, to an analog subscriber line TLa and TLb, respectively, by which a connection is established with the subscriber line circuit TLMAa of the exchange LE1 or TLMAb of the exchange LE2. These subscriber lines TLa, TLb serve also and primarily for the connection of a telephone set Tela or Telb to said subscriber line circuits.

Parts of interest here of the subscriber line circuits are a hybrid circuit Ga or Gb for the two-wire/four-wire transmission from the subscriber line to the four-wire transmission branches of the exchange, amplifiers V lying in these four-wire branches and an analog/digital converter AD in the transmitting branch and a digital/analog converter DA in the receiving branch. A digital signal processor DSP, to which the output signals of the analog/digital converter AD are fed, and which leads digital signals to the digital/analog converter DA, is a further component part. On the exchange side, the digital signal processor DSP is on the one hand in connection with the switching matrix SNa or SNb of the telephone exchange concerned, on the other hand it forms an interface with respect to a data network DN, for example an ATM network or the Ethernet.

Also represented as a component part of the subscriber line circuits is a controller CTR, which controls the digital signal processor DSP and supplies signaling information for the establishment of telephone connections, in which context it communicates with the corresponding controller of the

exchange of the calling subscriber via a signaling connection existing between the two exchanges.

The subscriber link UB between the two exchanges LE1 and LE2
5 is connected via line circuits TLMDa or TLMDb to the switching matrices of these exchanges.

In a connection of the data terminal PCa to the data terminal PCb, the digital data supplied by these data terminals are
10 converted in the modem Moda or Modb into analog signals and modulated onto a carrier wave for the transmission on the subscriber line TLa. In previous modem connections, in which the handling of the data signals in the devices of the telephone exchange and on the transmission path underwent the
15 same handling as voice information of the telephone traffic, this carrier frequency had, with regard to the limited transmission bandwidth for voice information of 3 kHz, a frequency of, for example, 2.6 kHz. In the subscriber line circuit TLMDa, these data, transmitted in the form of analog
20 signals, are subjected to an analog/digital conversion by the analog/digital converter ADA. The sampling rate of previous analog/digital converters was 8 ksamples/s, whereby, after a compression corresponding to a nonlinear characteristic into a code representation using 8 bits per code word, the standard
25 transmission bit rate of 64k bits/s for telephone connections was maintained.

According to the invention, however, a sampling of the analog signals corresponding to data supplied by the data terminal at
30 a sampling rate lying significantly above the sampling rate for voice information, to be specific for example at 64 ksamples/s, now takes place in the analog/digital conversion. The coding of the digital signals in this case takes place according to a linear characteristic with, for example, 16

bits. These digital signals are fed via the digital signal processor to the data network DN, in which a data transmission can take place under the preconditions mentioned at a transmission rate of approximately 1 Mbit/s.

5

The measures mentioned here for the handling of the data originating from the data terminals, to be specific the sampling at a higher sampling rate and the avoidance of the compression intended for the voice signal information, can also be used as an alternative if lower data transmission rates are adequate.

15

Since the analog/digital conversion of the voice information takes place in practice with the same analog/digital converter ADA, the corresponding digital signals are processed in the digital signal processor in such a way that they correspond to the unchanged and internationally standardized transmission conditions for telephone signal transmission, i.e. are reduced to 8000 sampling values per second and are compressed according to a nonlinear characteristic to a code representation of code words comprising 8 bits. On the other side, i.e. in the subscriber circuit TLMAb and the modem Modb, corresponding processes take place.

25

For the analog/digital conversion, essentially any desired converter principles come into consideration, just as long as they allow the high sampling rates in the form of a multiple of 8000 sampling values per second and the representation of the digital signals as code words with more than 8 bits.

30

Particularly suitable in this context, however, is a so-called sigma/delta converter, which operates at a very high sampling rate (10 MHz), but uses only one or two bits for the digital signal representation. With the aid of the digital signal processor, in this case a decimation to a lower number of

sampling values and a change of the code representation to code words of, for example, 16 bits is achieved.

If conventional hardware is still being used on the other side
5 of a modem connection, it is of course also possible when
using the subscriber circuit described to continue with the
data transmission over the telephone network, for which
purpose the digital signal processor DSP processes the digital
signals supplied by the analog/digital converter according to
10 the low transmission bandwidth and transmission bit rate, as a
result of which, however, the advantages offered by the novel
analog/digital converter are not utilized.

Patent claims

1. A method of handling telephone signals supplied by an analog telephone set and data supplied by a data terminal in the subscriber line circuit of a digital telephone switching system which is used at least in subregions for a data transmission, to which circuit the telephone set is connected directly and the data terminal is connected with a modem interposed via a common analog subscriber line, characterized in that, during the required analog/digital conversion, at least the data supplied by the data terminal (PCa, PCb) are subjected to a sampling operation at a sampling rate which lies above the sampling rate required for telephone information and/or the sampling values representing data supplied by the data terminal undergo a coding operation according to a linear characteristic, and in that the data originating from the data terminal and handled in such a way are fed directly to a data transmission network (DN).
2. The method as claimed in claim 1, characterized in that, for the transmission on the subscriber line (TL), the data signals supplied by the data terminals (PCa, PCb) are modulated onto a carrier signal, the frequency of which lies above the frequency band authorized for the transmission of telephone signals.
3. A subscriber line circuit for handling telephone signals supplied by an analog telephone set and data supplied by a data terminal in the subscriber line circuit of a digital telephone switching system which is used at least in subregions for a data transmission, to which circuit the telephone set is connected directly and the data terminal is connected with a modem interposed via a common analog subscriber line, characterized by an analog/digital converter

with a high sampling rate, above that required for telephone information, to which converter both the telephone signals supplied by the telephone set (Te1a, Te1b) and the data signals supplied by the data terminal (PCa, PCb) are fed, and
5 characterized by a digital signal processor (DSP), which reduces the digital signals emitted by the analog/digital converter, at least as long as they represent telephone signals, to the transmission bit rate intended for the transmission and which at the same time subjects the signals
10 representing telephone signals to a coding operation according to a nonlinear characteristic.

4. The subscriber line circuit as claimed in claim 3, characterized in that it has a digital interface, via which
15 the digital signals emitted by the digital signal processor, as long as they represent signals of the data terminal, are fed to a data network (DN) and digital signals coming from there, intended for the data terminal (PCa, PCb), are fed to the digital signal processor (DSP).

20

Fetherstonhaugh & Co.
Ottawa, Canada
Patent Agents

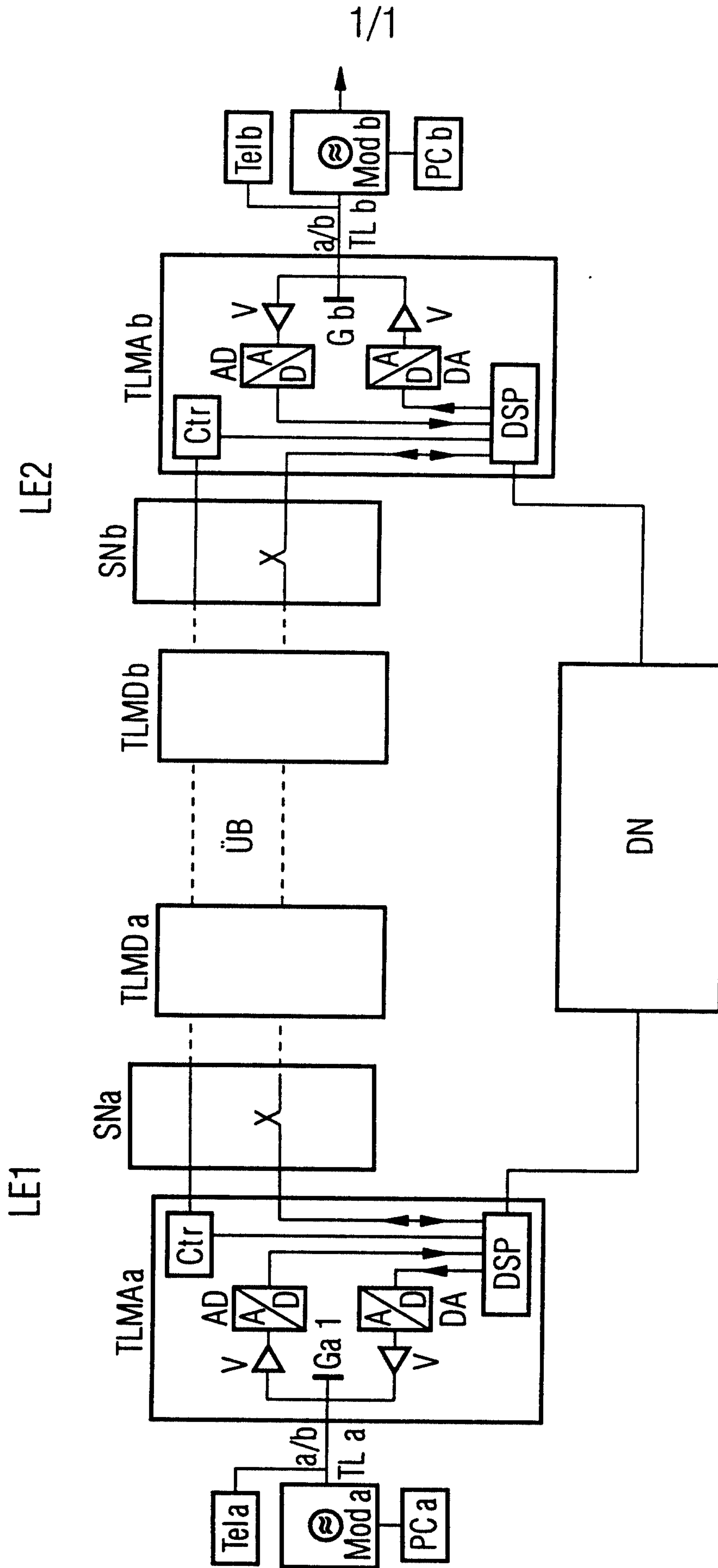

LE1

LE2

