

No. 759,922.

PATENTED MAY 17, 1904.

M. G. SCHWAB.
CONVEYER.

APPLICATION FILED JUNE 20, 1903.

NO MODEL.

2 SHEETS—SHEET 1.

Fig. 1.

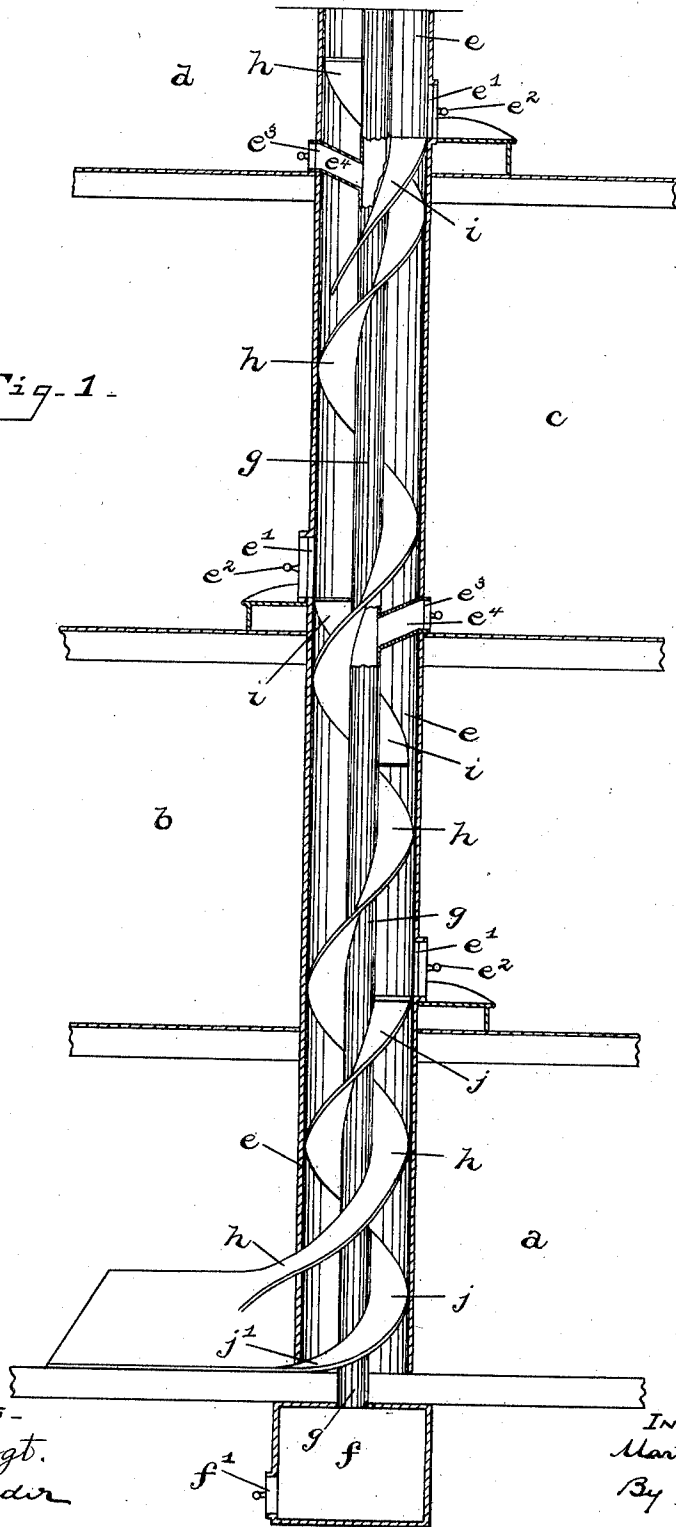

WITNESSES -
S. F. Vogt.
A. C. Sadler

INVENTOR -
Martin C. Schwab
By *Mann Co.*
Attys.

M. C. SCHWAB.
CONVEYER.

APPLICATION FILED JUNE 20, 1903.

NO MODEL.

2 SHEETS—SHEET 2.

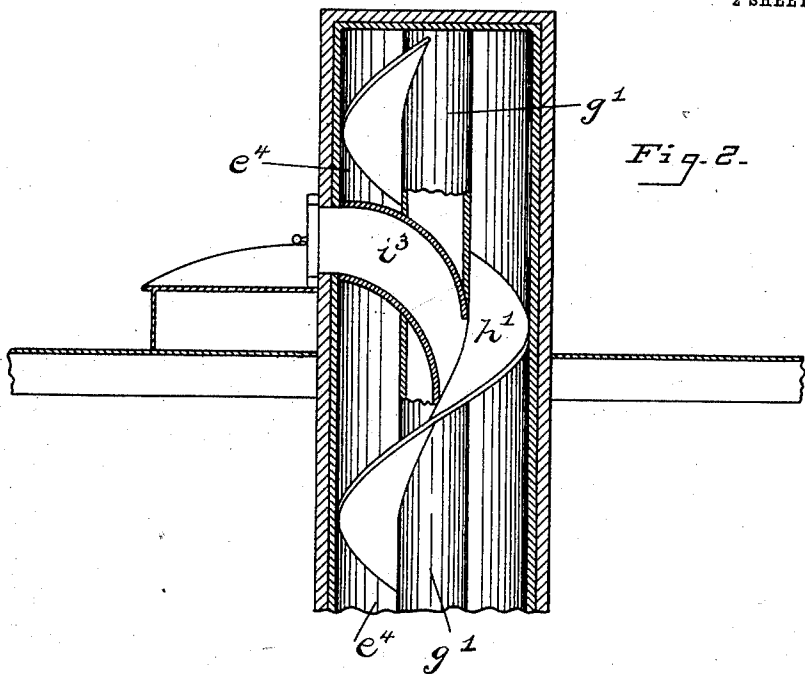

Fig. 2.

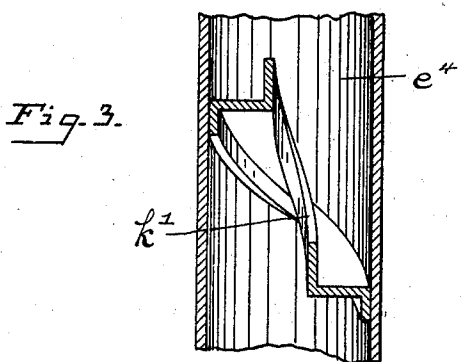

Fig. 3.

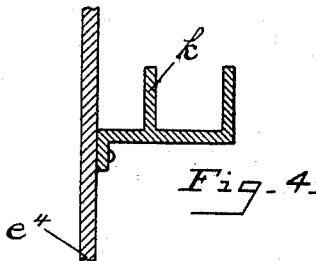

Fig. 4.

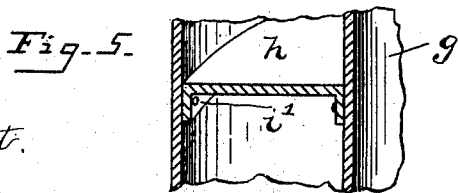

Fig. 5.

WITNESSES—
J. F. Vogt.
A. C. Eador

INVENTOR—
Martin C. Schwab
By Mann & Co.,
ATTYS.

UNITED STATES PATENT OFFICE.

MARTIN C. SCHWAB, OF BALTIMORE, MARYLAND.

CONVEYER.

SPECIFICATION forming part of Letters Patent No. 759,922, dated May 17, 1904.

Application filed June 20, 1903. Serial No. 162,355. (No model.)

To all whom it may concern:

Be it known that I, MARTIN C. SCHWAB, a citizen of the United States, residing at Baltimore, State of Maryland, have invented certain new and useful Improvements in Conveyers, of which the following is a specification.

This invention relates to certain improvements in spiral conveyers for use in buildings for transmitting packages from the various floors to the shipping-room or from one floor to another and is an improvement in conveyers such as are shown in Letters Patent of the United States No. 702,115, granted to me.

One object of the invention is to provide a conveyer where a central core is employed for conveying dirt from the various floors to the basement or other point.

With this and other objects in view the invention is illustrated in the accompanying drawings, in which—

Figure 1 is a vertical sectional view of the improved conveyer. Fig. 2 illustrates a construction in which the auxiliary chute passes through the central core or tube. Figs. 3, 4, and 5 illustrate modifications of the construction of spiral chutes.

In Fig. 1 of the drawings the invention is illustrated as installed in a building having four floors *a*, *b*, *c*, and *d*. The lower floor *a* in the present instance represents the shipping department and the upper floors *b*, *c*, and *d* the various sales departments. It is obvious that the device may be installed in a building having any number of floors and may be located in any convenient place in the building consistent with the architectural plan thereof.

The conveyer comprises an outer cylinder *e*, which extends vertically from the shipping department *a* up through the various floors of the building. A central tube or core *g* extends vertically through the cylinder *e*, and the lower end of said tube or core is in communication with the compartment or chamber *f*. This tube preferably extends throughout the entire length of the cylinder *e* and is supported centrally in said cylinder by the spirals or in any suitable manner. The cylinder *e* is also provided with a plurality of openings *e'* at the various floors, and each of said open-

ings, which are intended for packages, are provided with doors *e''* of any suitable construction. The cylinder is also provided with one or more openings *e'''*, flush with the floor, and a declining pipe forms a passage-way *e''''*, arranged to connect said opening *e'''* with the interior of the central tube or core *g*. This passage-way *e''''* serves to conduct dirt or refuse from the exterior of the cylinder *e* to the interior of the tube or core *g*, through which latter it is conducted to and deposited in the compartment or chamber *f*. This chamber is provided with a door *f'*, through which the dirt may be removed. A main spiral chute *h* extends vertically within the cylinder *e* from the shipping department *a* and surrounds the tube or core *g*.

It sometimes happens because of the architectural plan of a building that the main spiral chute may not be at a height from a given floor of a building to be conveniently accessible, and in order to overcome this the auxiliary spiral *i*, as shown in my patent before alluded to, extends from the openings *e'* down and partly around the central tube or core *g*, so that a package may be placed on said auxiliary spiral chute *i*, and thereby conveyed downwardly and deposited onto the main spiral *h*. This auxiliary spiral also covers or takes over the main spiral at the various openings *e'* and prevent any one at said opening from removing packages while in transit to the shipping department. These spiral chutes may be constructed in any practical manner and may be provided at the side with a downturned flange *i'*, (see Fig. 5,) by means of which the same may be riveted to the cylinder *e* or the tube or core *g*. By this construction it will be seen that the top surface of the spirals is smooth and free of obstructions.

A supplemental spiral *j* for small valuable packages extends from the one floor, which in this case is floor *b*, to the shipping department and discharge at *j'*. This is useful in transmission of certain articles, such as jewelry or other valuable packages, to the shipping department that the same be discharged on the same floor with the main spiral, but in a place separate from those discharged by the main spiral.

It may also sometimes happen that the auxiliary spiral chutes cannot be arranged so as to encircle the tube or core g at some of the floors of a building in consequence of a girder
 5 or some other obstruction in the way. To overcome this, I provide an auxiliary or supplemental chute i^3 , as seen in Fig. 2, which opens through the wall of the cylinder e^4 and extends downwardly and through the central
 10 vertical tube or core g' and delivers onto the main spiral chute h' .

It is to be understood that the chutes are not confined to any particular construction either for the main or auxiliary spirals, as the same may be constructed in numerous ways,
 15 examples of which are shown in Figs. 3, 4, and 5.

In Fig. 3 the spiral chute is provided with an upward vertical flange h' , and in Fig. 4 the chute is illustrated as having a plurality of
 20 vertical flanges h .

Having thus fully described my invention, what I claim as new, and desire to secure by Letters Patent, is—

25 1. A conveyer for transmitting packages from one floor to another of a building comprising an outer cylinder; a tube or core extending vertically through said outer cylinder in combination with a spiral chute extending
 30 vertically through the outer cylinder and being in communication with the several floors, and a passage-way establishing communication between the interior of the central tube or core and a floor.

35 2. A conveyer for transmitting packages

from one floor to another of a building comprising an outer cylinder; a central tube or core extending vertically through said outer cylinder; a compartment at the lower end of
 40 said tube or core, and a passage-way opening through the wall of the outer cylinder and opening on the interior of the central tube or core for the purpose set forth.

3. A conveyer for transmitting packages from one floor to another of a building hav-
 45 ing in combination a central tube or core; a main spiral chute, h , extending vertically and surrounding said tube or core and discharging at a given floor; and a supplemental spiral chute, j , establishing communication be-
 50 tween an upper floor and the same floor as the main spiral but discharging in a separate place from the main spiral.

4. A conveyer for transmitting packages from one floor to another of a building hav-
 55 ing in combination an outer tube or cylinder; a tube or core extending vertically through said outer cylinder; a spiral chute interposed between said cylinder and said tube or core and surrounding said tube or core; and a pas-
 60 sage-way opening through the wall of said outer cylinder and extending through the interior of said tube or core and delivering onto said spiral chute.

In testimony whereof I affix my signature in
 65 the presence of two witnesses.

MARTIN C. SCHWAB.

Witnesses:

CHARLES B. MANN, JR.,
 G. FERDINAND VOGT.