

[54] PULP PICKING APPARATUS WITH IMPROVED FIBER FORMING DUCT

[76] Inventor: David W. Appel, Neenah, Wis. 54956

[22] Filed: Dec. 20, 1971

[21] Appl. No.: 209,935

Related U.S. Application Data

[63] Continuation-in-part of Ser. No. 882,265, Dec. 4, 1969, abandoned.

[52] U.S. Cl. 19/156.3

[51] Int. Cl. D01g 25/00

[58] Field of Search. 57/50, 58.95; 19/156.3, 156.4, 19/89, 88; 241/18, 47, 57, 49

[56] References Cited

UNITED STATES PATENTS

3,360,918 1/1968 Doudlebsky 57/58.95

Primary Examiner—Dorsey Newton

Attorney, Agent, or Firm—C. Frederick Leydig et al.

[57] ABSTRACT

An apparatus and method for airlaying wood pulp fibers which avoids fiber floccing is disclosed. Wood pulp sheets are delimitated with a picker roll and the individual fibers are conveyed through a forming duct to a collecting screen. The position of the forming duct with respect to the picker roll and the size of the duct are such that the fibers separated from the sheets maintain substantially the same velocity during their travel through the forming duct. A process air duct for supplying air to transport the fibers to the collecting surface is used; and, when high picking rates are desired, a supplemental air duct is also employed.

4 Claims, 4 Drawing Figures

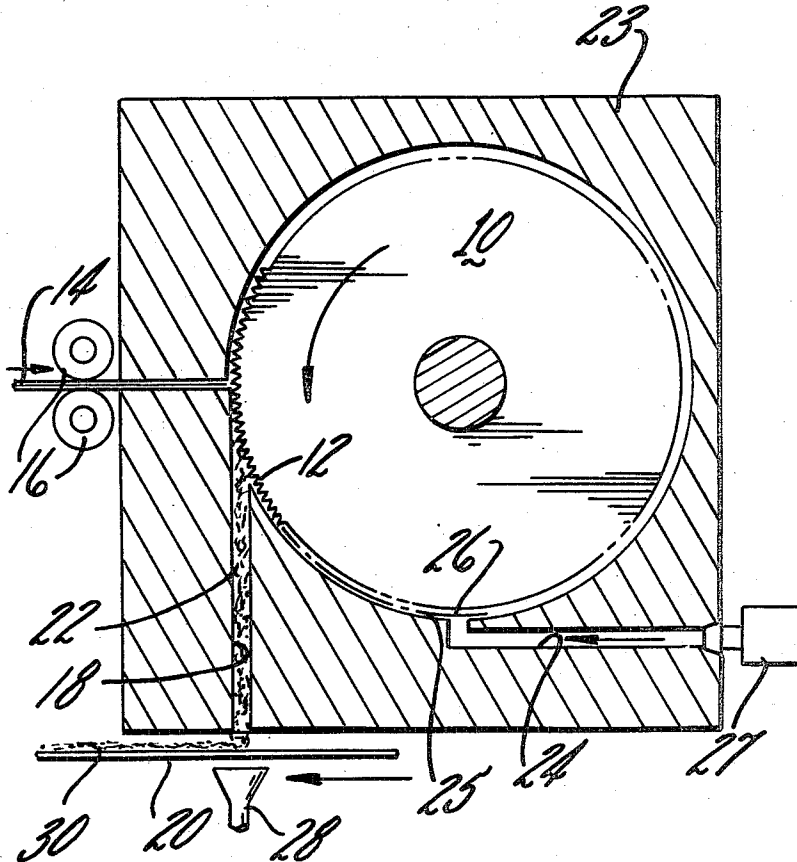

FIG. 1

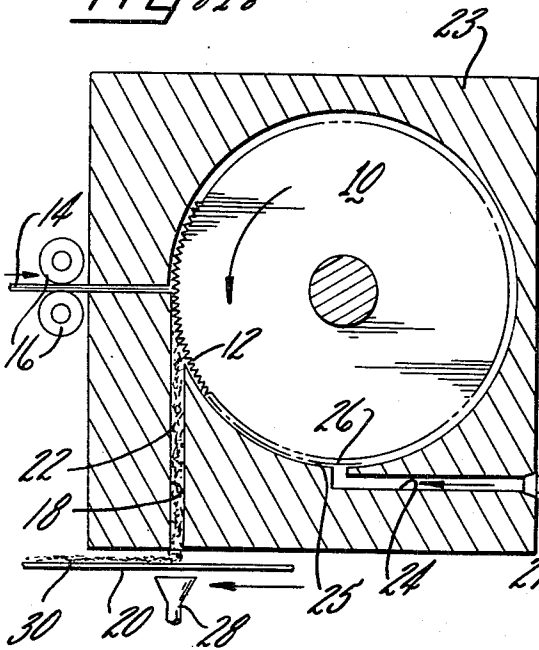

FIG. 2

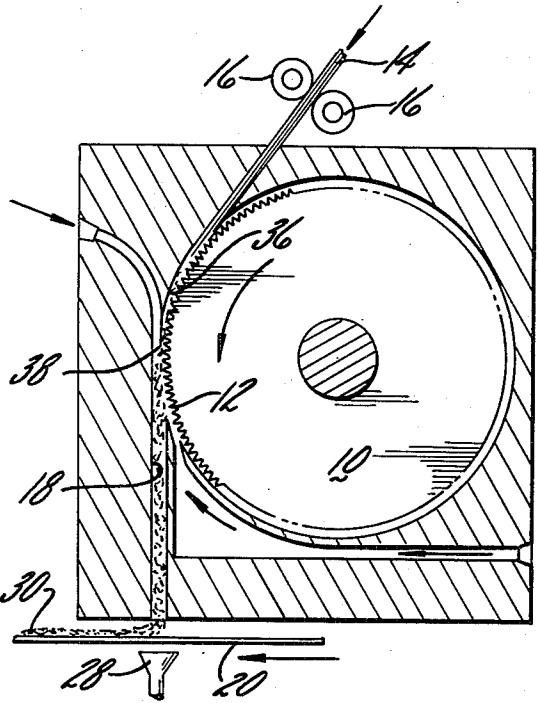
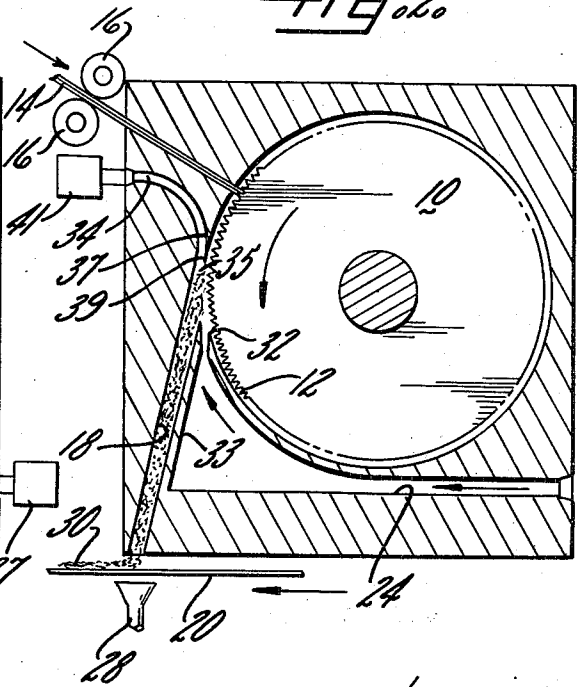

FIG. 3

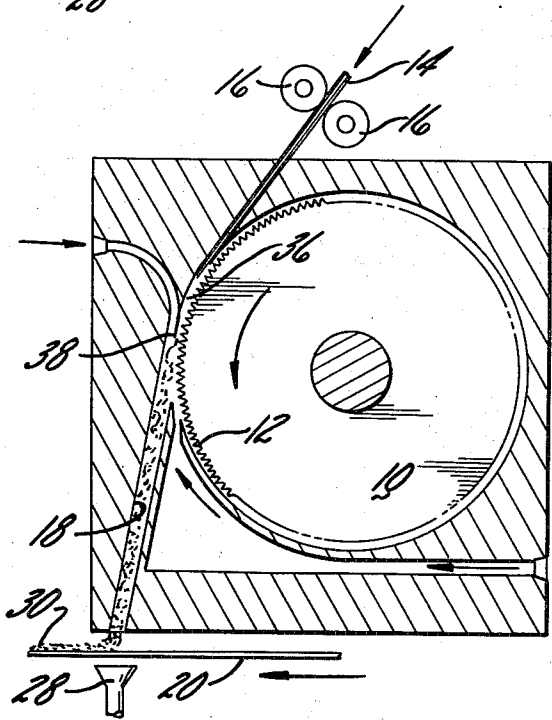

FIG. 4

PULP PICKING APPARATUS WITH IMPROVED FIBER FORMING DUCT

RELATED APPLICATIONS

Appel, U.S. Pat. Ser. No. 882,265, filed Dec. 4, 1969, now abandoned entitled "Pulp Picking Apparatus With Improved Fiber Forming Duct," of which the present application is a continuation-in-part.

Appel and Sanford, U.S. Pat. Ser. No. 882,258, filed Dec. 4, 1969, now U.S. Pat. No. 3,606,175, entitled "Picker for Divellicating Pulp."

DESCRIPTION OF THE INVENTION

The present invention is directed to the preparation of wood pulp fiber webs and, more particularly, to an apparatus and process for preparing a loose batt or web of wood pulp fibers characterized by its uniformity and substantial freedom from fiber floccing.

Techniques for divellicating wood pulp and reassembling the same in the form of soft webs of relatively individualized fibers are well known. Customarily, compacted wood pulp sheets are fed to a hammer mill or picker roll which divellicates the sheets into individual fibers. The fibers are thereafter deposited on a supporting surface such as a foraminous screen. The screen generally has suction means associated with it so as to facilitate fiber formation thereon and is usually moving continuously in a direction generally transverse to the direction of fiber delivery.

While the known methods seek to form webs wherein the fibers are in a highly uniform arrangement, as a practical matter, significant fiber clumping or agglomeration, generally referred to as fiber floccing, occurs. Such fiber floccing is at least partly a result of fiber entanglement as the fibers are conveyed from the picker roll to the supporting surface. Also, webs formed by conventional methods usually have a non-uniform distribution of basis weight across the width of the webs.

While the fiber webs prepared by conventional processes can be used in a number of applications, there are some uses wherein a web substantially free of fiber floccing and highly uniform across its width would be desirable. In particular, as described in the U.S. Pat. application of C. E. Dunning, titled "Air Formed Webs and Method For Making Such Webs," Ser. No., 882,257, filed Dec. 4, 1969, useful paper products with a desirable combination of strength, tactile, and absorbency characteristics can be prepared from soft webs of wood pulp fibers. While conventionally prepared fiber webs can be used in the aforementioned paper making process, the use of highly uniform webs substantially free from fiber floccing would be advantageous.

Accordingly, it is an object of the present invention to provide a uniform web of individual fibers which is substantially free of fiber floccing. It is a further object to provide a method and apparatus for preparing such fiber webs. It is a still further object of the present invention to provide a method and apparatus whereby individual fibers from divellicated pulp sheets can be conveyed directly after their separation from the sheets to a fiber supporting surface at substantially the same velocity at which they are separated.

Other objects and advantages will become apparent upon reading the following detailed description and upon reference to the drawings, in which:

FIG. 1 is a schematic side elevation view and illustrates one embodiment of the apparatus of the present invention showing a radial pulp feed and a forming duct positioned normal to the collecting surface;

FIG. 2 is a schematic side elevation view and shows another embodiment of the apparatus of the present invention having a radial pulp feed and forming duct inclined with respect to the collecting surface;

FIG. 3 is a schematic side elevation view and illustrates a further embodiment of the apparatus of the present invention including a spiral pulp feed and a normal forming duct and

FIG. 4 is a schematic side elevation view and shows still another embodiment of the apparatus of the present invention showing a spiral pulp feed and an inclined forming duct.

While the invention is susceptible to various modifications and alternative forms, specific embodiments thereof have been shown by way of example in the drawings and will herein be described in detail. It should be understood, however, that it is not intended to limit the invention to the particular forms disclosed, but, on the contrary, the intention is to cover all modifications, equivalents and alternatives falling within the spirit and scope of the invention as expressed in the appended claims.

Turning to the drawings, FIG. 1 illustrates an apparatus useful for divellicating pulp sheet according to the present invention. As shown, the apparatus comprises a conventional picker roll 10 having picking teeth 12. Pulp sheets 14 are radially fed, i.e., along a picker roll radius, to the picker roll 10 by means of the rolls 16. The picker teeth 12 divellicate the pulp sheets 14 into individual fibers 22. After separation from the sheets, the fibers are conveyed to the moving foraminous screen 20 through the forming duct 18. A housing 23 encloses the picker roll 10 and provides a passage 25 between the housing and the picker roll surface. Process air 24 is supplied to the picker roll in the passage 25 via duct 26 in sufficient quantity to serve as a medium for conveying the fibers 22 through the forming duct 18 at a velocity approaching that of the picker teeth. The air may be supplied by any conventional means as, for example, a blower 27. Suction means 28 positioned below the screen 20 at the duct exit of a sufficient capacity to accept the air flow from the duct aid in the formation of the fibers into a web 30 on the moving foraminous collecting screen 20.

It has been found that, in order, to avoid fiber floccing, the individual fibers should be conveyed through the forming duct 18 at substantially the same velocity at which they leave the picker teeth 12 after separation from the pulp sheets 14, i.e., the fibers should maintain their velocity in both magnitude and direction from the point where they leave the picker teeth. Moreover, as used herein, "substantially the same" means that the velocity at which the fibers separate from the pulp sheets does not change by more than about 50 percent and, preferably, by not more than about 20 percent, in the forming duct. This is in contrast with conventional forming apparatus in which, due to flow separation, fibers do not travel in an ordered manner from the picker to the supporting surface; and, consequently, fibers velocities change as much as 100 percent or more during conveyance to a supporting surface.

In accordance with one aspect of the present invention, fiber velocity is maintained substantially the same

by suitable positioning and sizing of the duct. To this end, the forming duct is positioned such that its longitudinal axis is substantially parallel to the plane which is tangent to the picker teeth at the point at which the fibers leave the influence of the picker teeth. In such a position, fiber velocity is not changed by impingement on the duct walls. Thus, where the pulp sheets 14 (FIG. 1) are radially fed to the picker in a plane which is substantially parallel to the screen 20, the plane which is tangent to the picker teeth 12 at the point of contact with the pulp sheets is perpendicular to the screen 20. Accordingly, since for the schematic embodiment illustrated in FIG. 1, the point of picker contact with the sheets is also the point at which the separated fibers leave the influence of the picker teeth, the longitudinal axis of the forming duct is normal to the screen 20. However, if after separation from the pulp sheets, the fibers are constrained to remain under the influence of the picker teeth, e.g., as in FIG. 1, of U.S. Pat. No. 3,268,954 to Joa and further embodiments described herein, then the axis of the forming duct is appropriately adjusted so as to be in the direction of fiber velocity at that point where constraint is no longer present.

Aside from the above discussed parallel relationship of the longitudinal axis of the duct, the duct size is also important. As shown in FIG. 1, the width of the duct is approximately equal to the height of the picker teeth 12, the passage between the picker teeth and the picker roll housing being very small. With such a duct width, the velocity of the process air supplied through process air duct 26 remains substantially constant in its travel with the picker and thence through the duct 18. Furthermore, since as indicated earlier, the velocity of the process air approaches that of the picker teeth which, in turn, is about that of the separated fibers, the process air causes no substantial variations in fiber velocity as it conveys the fibers in the duct to the screen. With duct widths approximately equal to the height of the picker teeth, e.g., no more than about 1.5 times the tooth height, air velocities in the forming duct of at least 70 percent of the picker tooth velocity are useful in the illustrated apparatus.

Duct length and transverse width, i.e., the width in a direction along the picker roll axis, are also important in order to achieve an optimum web. Preferably, the duct length should be as short as the overall equipment design will allow. For the apparatus schematically illustrated in FIG. 1, the shortest duct length is limited by the radius of the picker roll. In order to achieve a high degree of cross-width uniformity in the resultant web, the transverse duct width preferably should not exceed the width of the pulp sheets fed to the picker roll.

Again referring to the apparatus illustrated in FIG. 1, it is preferred that picker teeth with relatively large heights, e.g., greater than one fourth inch, be used. Such heights permit the use of wider forming ducts which, in turn, minimize the interaction of fibers with the duct walls. Further embodiments, discussed hereinafter, illustrate other means for minimizing this interaction.

Additional aspects of the present invention are illustrated in FIG. 2. As in FIG. 1, pulp sheets 14 are radially fed to the picker roll 10 having teeth 12 by means of the rolls 16. However, as shown in FIG. 2, the plane of the pulp sheets fed to the picker is not parallel to the moving screen 20, and, consequently, the plane tangent to the picker teeth at their point of contact with pulp

sheets is inclined with respect to the perpendicular to the moving screen. Thus, in accordance with the above discussion, the position of the forming duct is such that its longitudinal axis is also inclined with respect to the perpendicular to the moving screen; the angle of inclination being substantially the same as that of the plane tangent to the teeth at the point of contact with the pulp sheet.

The use of an inclined forming duct as illustrated in FIG. 2 is particularly useful where high picking rates are employed and the screen 20 is moving at a high speed. Fibers impinging upon the screen from an inclined forming duct have a component of velocity in the direction of screen movement and, accordingly, fiber disruption is minimized.

An additional aspect of the present invention is also illustrated in FIG. 2, and involves the introduction of the process air through duct 24 at a point 32 which is close to the entrance to the forming duct 18. In this embodiment the upstream wall 33 of the forming duct is common to the process air duct. An arrangement such as depicted is particularly suitable when the picker roll is to be rotated at high speeds and/or large teeth heights are used. Under such circumstances, the pumping effect of the rotating roll tends to carry air and fibers from the forming duct into the picker housing. This can result in fiber clumps developing in the housing and the consequent conveyance of such clumps around the picker teeth and through the duct. By introducing the process air near the entrance to the forming duct, the pumping effect of the roll can be counteracted and fiber circulation around the housing prevented. Also, in such a position, the process air serves to strip clinging fibers from the picker teeth. Simple experimentation can be used to establish the appropriate process air flow rate to obtain an optimum web under the desired operating conditions. Also, the appropriate flow rate can be visually determined by providing a window (not shown) in the housing so that the interior of the forming duct can be observed. In this instance, the flow rate is set so that fibers do not buildup on the nose 35 of the forming duct wall 33.

It should be appreciated that positioning the entrance of the process air duct 24 to the passage 25 a distance away from the communication of the forming duct with the passage (as in FIG. 1) may also be employed to prevent fibers and process air from being drawn into the passage from the forming duct. Positioning of the process air duct against the forming duct (as in FIG. 2) is, however, preferred. This allows the usage of less air pressure since the FIG. 1 embodiment must overcome the pumping action in the portion of the passage from the forming duct entrance to the point at which the process air is admitted.

The positioning of the entrance of the process air duct adjacent the forming duct, as in FIG. 2, has the further advantage in that control of the process air in the cross-direction is enhanced. Thus, while the FIG. 1 embodiment is capable of providing uniformity of air pressure across the machine width, the air supplied must overcome the pumping action caused by the rotating picker, a pumping action which may be variable. Use of this embodiment accordingly requires more pressure than is theoretically necessary to provide a safety factor insuring that process air and fibers all across the width are not allowed to enter the passage 25. This can result in localized areas having excessive

air pressure, causing undesirable air turbulence in the forming duct which could disturb the desired uniformity of the fiber transportation to the foraminous collecting surface.

Positioning the process air duct as close to the forming duct as possible, as in the FIG. 2 embodiment, obviates these potential problems. The air is supplied where it is needed and may be provided at a rate and pressure sufficient to prevent process air and fibers from entering the passage 25. There is no need to supply excess air to oppose the pumping action generated by the picker from the entrance of the passage 25 at the forming duct to the entrance of the process air duct since this distance is minimal in the FIG. 2 embodiment.

In accordance with a further aspect of the present invention, means are provided to further insure that the air pressure entering the passage 25 is substantially uniform in the widthwise direction. To this end, and as shown in FIG. 2, the process air duct 24 is considerably larger in size than the duct entrance to the passage (shown at point 32). The process air duct 24 should be sufficiently larger than the duct entrance so that there is less than about 1 or 2 percent variation in pressure across the width, preferably less than 1 percent. This can be accomplished by having the duct width 10 times that of the entrance to the passage 25. Variations of about 3 to 4 percent begin to disturb the desired uniformity of the formed web.

According to a still further feature of the present invention, means are provided to supply supplemental air to the forming duct. The use of supplemental air is particularly desirable at high picking rates. With high picking rates and the associated high fiber concentrations in the forming duct, more floccing tends to occur through such mechanisms as mechanical entanglement and fiber attraction due to static charge. Using supplemental air allows a wider duct so that the fiber concentration is diminished through the mild mixing of the two air streams at their adjacent boundaries and results in a desirably greater degree of fiber separation and less fiber interaction. To this end, and as is shown in FIG. 2, supplemental air is introduced into the forming duct 18 through a supplemental air duct 34, communicating with the forming duct adjacent the entry of the separated fibers and the process air into the forming duct. The speed and direction of the supplemental air must be substantially the same as the speed and direction of the process air and fibers so as to avoid turbulence or severe mixing which would result in fiber floccing. The interior wall 37 of the supplemental air duct 34 is contoured to provide a smooth flow and terminates at a point 39 where the supplemental air and process air merge.

The use of supplemental air allows the forming duct to have a width of up to about four times the height of the picking teeth. Thus, for picker teeth heights of one-fourth inch, the duct width may be about 1 inch. The source of air may be any conventionally used source such as, for example, a blower 41, the sole requirement being that the capacity is sufficient to achieve the requisite air velocity.

FIGS. 3 and 4 illustrate further embodiments of the present invention. As shown therein, the pulp sheets 14 are spirally fed to the picker 10 rather than radially fed as shown in FIGS. 1 and 2. The various aspects and advantages of spiral pulp feeds are set forth in detail in the Appel and Sanford patent previously identified. Briefly,

spiral feeding permits high picking rates without fiber breakage, scorching, or burning. Referring to FIGS. 3 and 4, such spiral picking is accomplished by use of a pulp sheet feed guide 36, the geometry of which is described in the aforementioned patent, which spirally guides the pulp sheets 14 into contact with the picker teeth 12. At the end 38 of the feed guide 36, there is approximately zero clearance between the guide and the picker teeth.

As illustrated in FIGS. 3 and 4, when using a spiral feed the longitudinal axis of the forming duct 18 is parallel to the plane tangent to the picker teeth at the point of approximately zero clearance between the teeth and the guide. Although, picking of the sheets starts at the entrance to the feed guide, separated fibers do not leave the influence of the teeth until the point of approximately zero clearance is reached. Also, as illustrated, an inclined forming duct, a supplemental air supply, and an appropriate positioning of the process air entrance can be advantageously used with spiral pulp feed.

Thus, as described above, the illustrated apparatus can be used to form uniform webs which are substantially free from fiber floccing. The webs so formed can be of any weight desired, varying from an essentially single fiber layer to thick batts. As an illustrative example, the apparatus depicted in FIG. 1 wherein the picker roll is 12 inches in diameter, 13 inches long, and has teeth with a height of three-eighths inch can be used to divellicate a combination of 4 wood pulp sheets, each of which is 0.0009 inch thick with a basis weight of 70 lbs. per 2,880 ft.². When doing such, a speed of 8,000 FPM (teeth speed) and a forming duct width of one half inch are useful.

I claim as my invention:

1. In an apparatus for forming an airlaid web which comprises a rotatable divellicating means having teeth thereon for separating a compacted fiber sheet into its individual fibers, a housing enclosing the divellicating means and providing a passage between the housing and the divellicating means, a foraminous moving surface for collecting the fibers to form a web thereon, a forming duct positioned between the divellicating means and the moving surface through which the separated fibers leaving the divellicating means are transported to the moving surface and communicating with the passage, a suction means disposed below the foraminous surface to assist in collecting the fibers on the surface and wherein the rotation of the divellicating means creates a pumping action in the passage to provide moving process air for transporting the separated fibers through the forming duct to the collecting surface and the pumping action tends to cause part of the process air to enter the passage, the improvement comprising said forming duct having a limited area path through which the separated fibers and process air are transported to the collecting surface, the width of said forming duct being approximately equal to the height of the teeth of said divellicating means, a process air duct communicating with the passage and means for supplying air to said process air duct at a pressure and a rate sufficient to substantially prevent process air in said forming duct from entering the passage.

2. The apparatus of claim 1 wherein said forming duct and process air duct have a common wall and said process air duct is positioned to cause the process air to communicate with the passage adjacent the point at

7

8

which said forming duct communicates with the passage.

3. The apparatus of claim 1 and wherein the longitudinal axis of said forming duct is inclined with respect to the perpendicular to the foraminous surface.

4. In an apparatus for forming an airlaid web which comprises a rotatable divellicating means having teeth thereon for separating a compacted fiber sheet into its individual fibers, a housing enclosing the divellicating means and providing a passage between the housing and the divellicating means, a foraminous moving surface for collecting the fibers to form a web thereon, a forming duct positioned between the divellicating means and the moving surface through which the separated fibers leaving the divellicating means are transported to the moving surface and communicating with the passage, a suction means disposed below the foraminous surface to assist in collecting the fibers on the surface and wherein the rotation of the divellicating means creates a pumping action in the passage to provide moving process air for transporting the separated fibers

through the forming duct to the collecting surface and the pumping action tends to cause part of the process air to enter the passage, the improvement comprising said forming duct having a limited area path through which the separated fibers and process air are transported to the collecting surface, a process air duct communicating with the passage, means for supply air to said process air duct at a pressure and at a rate sufficient to substantially prevent process air in said forming duct from entering the passage, a supplemental air duct communicating with said forming duct and positioned to allow air to enter said forming duct at a point adjacent the entry of the separated fibers into said forming duct and in the same direction as the process air, said forming duct width being up to about four times the height of the divellicating means teeth and means for supplying air to said supplemental air duct to provide entry of the supplemental air into said forming duct at substantially the same velocity as the process air.

* * * * *

25

30

35

40

45

50

55

60

65