



INTERNATIONAL APPLICATION PUBLISHED UNDER THE PATENT COOPERATION TREATY (PCT)

<p>(51) International Patent Classification ⁵ : B29C 43/18, 55/20, B28B 11/12</p>	<p>A1</p>	<p>(11) International Publication Number: WO 91/17035 (43) International Publication Date: 14 November 1991 (14.11.91)</p>
<p>(21) International Application Number: PCT/US91/02903 (22) International Filing Date: 26 April 1991 (26.04.91) (30) Priority data: 516,183 30 April 1990 (30.04.90) US (71) Applicants: ONTARIO DIE COMPANY OF AMERICA [US/US]; 2735 - 20th Street, Box 610397, Port Huron, MI 48061-0397 (US). ONTARIO DIE COMPANY LIMITED [CA/CA]; 119 Roger Street, Box 70, Waterloo, Ontario N2J 3Z6 (CA). (72) Inventors: PIOTROWSKI, Stanley ; 23 Wilhelm Street, Kitchener, Ontario N2H 5R7 (CA). LEVENE, Ronald, I. ; 339 Pommel Gate Crescent, Waterloo, Ontario N2L 5X7 (CA).</p>		<p>(74) Agents: WOOD, Donald, L. et al.; Krass & Young, 3001 West Big Beaver, Suite 624, Troy, MI 48084-3109 (US). (81) Designated States: AT (European patent), BE (European patent), CA, CH (European patent), DE (European patent), DK (European patent), ES (European patent), FR (European patent), GB (European patent), GR (European patent), IT (European patent), JP, LU (European patent), NL (European patent), SE (European patent). Published <i>With international search report.</i></p>

(54) Title: METHOD AND APPARATUS FOR PRODUCING STRUCTURAL INJECTION MOLDINGS

(57) Abstract

A die assembly including an upper male mold (42), an annular cutting blade (46), and pressure plate (80) carried by the upper plate (40) of an upper die set (18); and a female mold (24) secured to the lower plate (22) of a lower die set (16). The blade (46) is positioned in surrounding relation to the male mold (42); the pressure plate (80) is positioned in surrounding relation to the blade (46); and an annular seal (48) encircles male mold (42) within blade (46). The upper die set (18) clamps a sheet of component material (90) positioned over the female mold (24) and is moved downwardly into the cavity (24a) by selective slippage controlled by selective adjustment of the pressure plate (80). Stop means (30) are provided to delimit the downward movement of the male mold (42) whereafter a lost motion connection allows the die (18) to continue downwardly and the cutter blade (46) to trim the sheet edge with resin being injected through the female mold to permeate sheet material (90).

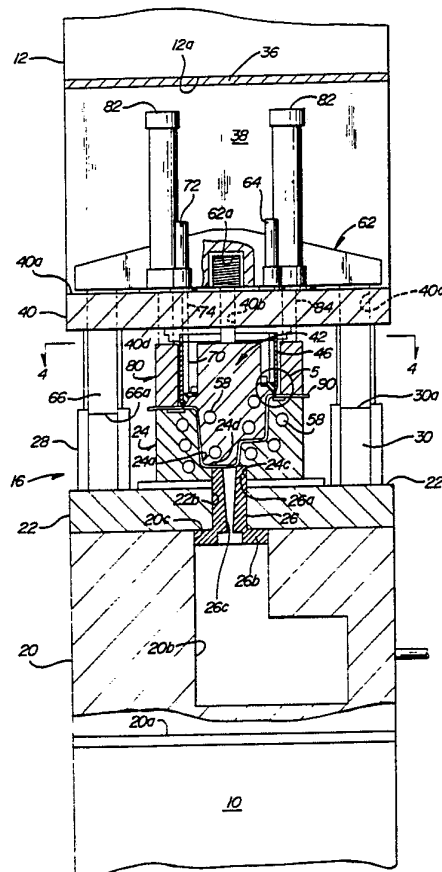

FOR THE PURPOSES OF INFORMATION ONLY

Codes used to identify States party to the PCT on the front pages of pamphlets publishing international applications under the PCT.

AT	Austria	ES	Spain	MG	Madagascar
AU	Australia	FI	Finland	ML	Mali
BB	Barbados	FR	France	MN	Mongolia
BE	Belgium	GA	Gabon	MR	Mauritania
BF	Burkina Faso	GB	United Kingdom	MW	Malawi
BG	Bulgaria	GN	Guinea	NL	Netherlands
BJ	Benin	GR	Greece	NO	Norway
BR	Brazil	HU	Hungary	PL	Poland
CA	Canada	IT	Italy	RO	Romania
CF	Central African Republic	JP	Japan	SD	Sudan
CG	Congo	KP	Democratic People's Republic of Korea	SE	Sweden
CH	Switzerland	KR	Republic of Korea	SN	Senegal
CI	Côte d'Ivoire	LI	Liechtenstein	SU	Soviet Union
CM	Cameroon	LK	Sri Lanka	TD	Chad
CS	Czechoslovakia	LU	Luxembourg	TG	Togo
DE	Germany	MC	Monaco	US	United States of America
DK	Denmark				

- 1 -

**METHOD AND APPARATUS FOR PRODUCING
STRUCTURAL INJECTION MOLDINGS**

Background of the Invention

This invention relates to structural injection molded parts and more particularly to an improved method and apparatus for forming such parts.

5 Structural injection molded parts are parts formed of an injection molded resin material with one or more sheets of reinforcing fabric or material embedded in the resin to enhance the structural strength of the part. Structural injection molded parts are finding increased application in many industries because they possess the moldability and formability characteristics of injection molded parts and yet have sufficient strength to enable them to be employed in applications where structural strength is critical. Whereas various methods and apparatus have heretofore been proposed to produce structural injection molded parts, the prior art methods and apparatus have been unduly complicated and expensive.

10
15

Summary of the Invention

20 This invention is directed to the provision of an improved method and apparatus for producing structural injection molded parts.

The invention methodology includes the steps of providing a mold assembly including a female mold part defining a concavity and a male mold part defining a convexity sized to fit into the concavity of the female

25

- 2 -

mold part to define a mold cavity corresponding to the shape of the part to be molded; positioning reinforcing material over the concavity of the female mold part; moving the male mold part convexity into the female mold part concavity to position the reinforcing material in the mold cavity; and injecting resin into the mold cavity to produce a structural injection molded part. This methodology allows all of the steps necessary to produce a structural injection molded part to be performed in a single continuous process.

According to a further feature of the invention methodology, the method includes the further step of trimming the material to the shape of the part after the material is moved into the mold cavity. This methodology allows the necessary trimming function to be readily incorporated into the invention methodology.

According to a further feature of the invention methodology, a closed loop cutting blade is positioned in surrounding relation to one of the mold parts and the trimming step is performed by moving the cutting blade relative to the surrounded mold part. This methodology provides a compact and efficient package for performing the forming and trimming functions.

According to a further feature of the invention methodology, the trimming step is performed before the resin injecting step. This arrangement allows the resin injection step to be confined to the configuration and extent of the finished part.

- 3 -

According to a further feature of the invention methodology, a seal is provided around the peripheral edge of the female mold concavity to preclude the escape of resin from the mold cavity.

5 According to a further feature of the invention, the trimming step is performed with a closed loop cutting blade and the seal is provided proximate the inner periphery of the cutting blade. This arrangement allows a convenient means of precluding the escape of resin between
10 the male mold and the cutting blade.

 According to a further feature of the invention methodology, the male mold part is positioned within the cutting blade and defines an annular interface with the cutting blade, a seal is positioned around the male mold
15 part at the interface between the male mold part and the cutting blade, and means are provided to press the seal into the interface between the male mold part and the cutting blade following the trimming step. This arrangement ensures that there will be no leakage of resin
20 between the cutting blade and the mold part.

 According to a further feature of the invention methodology, before the male mold part is moved into the female mold part concavity, the reinforcing material is clamped around the periphery of the concavity. This
25 arrangement allows selective control of the movement of the material into the mold cavity as the male mold part convexity is moved into the female mold part concavity.

 According to a further feature of the invention methodology, the reinforcing material is substantially non-

- 4 -

stretchable and the clamping step includes selectively controlling the clamping pressure to allow material to selectively slip pass the clamping interface to allow the male mold part to move into the concavity.

5 According to a further feature of the invention methodology, the clamping step includes selectively varying the clamping pressure around the clamped peripheral interface to provide a varying clamping force on the material as measured around the clamping interface. This
10 arrangement allows the slippage as between the clamping means and the material to be selectively controlled to selectively control the movement of the material into the mold cavity.

 According to a further feature of the invention
15 methodology, the resin injecting step is performed by introducing resin into the mold cavity through the female mold part. This arrangement simplifies the introduction of the resin into the mold cavity.

 The apparatus according to the invention includes
20 a mold assembly including a female mold part defining a concavity and a male mold part defining a convexity sized to fit into the female mold part concavity; and means for moving the mold parts between a retracted position in which the male mold part convexity is withdrawn from the female
25 mold part concavity and an inserted position in which the male part convexity is positioned within the female mold part concavity to define a mold cavity therebetween corresponding to the shape of the part to be molded and further define an access opening therebetween at the

- 5 -

periphery of the concavity providing access to the mold cavity from a location external to the mold assembly whereby to allow a sheet of reinforcing material to be positioned over the concavity with the mold parts in their retracted position whereafter the mold parts may be moved to their inserted positions to position the sheet within the mold cavity with edge portions thereof extending through the access opening to a location external to the mold cavity; and means for injecting resin into the mold cavity to impregnate the sheet of reinforcing material and form a reinforced structural injection molded part. This arrangement allows a single apparatus to perform all of the major steps required to produce a structural injection molded part.

15 According to a further feature of the invention apparatus, the apparatus further includes means for trimming the edge portions of the sheet. This arrangement allows the invention apparatus to further incorporate the means to trim the part to its final configuration.

20 According to a further feature of the invention apparatus, the trimming means comprises a cutting blade mounted in surrounding relation to the male mold part and mounted for cutting movement relative to the male mold part. This arrangement provides a convenient and compact package that provides an effective means for trimming the part.

 According to a further feature of the invention apparatus, the apparatus further includes means for clamping the edge portions of the sheet. This arrangement

- 6 -

allows the apparatus to control the movement of the sheet into the mold cavity.

According to a further feature of the invention apparatus, the clamping means comprises pressure plate
5 means positioned in surrounding relation to the male mold part. This arrangement provides a compact and efficient package and provides effective control of the movement of the material into the mold cavity.

According to a further feature of the invention
10 apparatus, means are providing for sealing the mold cavity proximate the access opening to the mold cavity. This arrangement ensures that resin will not escape from the mold cavity during the resin injection operation.

According to a further feature of the invention
15 apparatus, the sealing means includes a seal structure mounted in surrounding relation to the male mold part. This arrangement provides a convenient means of sealing the mold cavity.

According to a further feature of the invention
20 apparatus, the seal structure is mounted on the periphery of the male mold part and the apparatus further includes pressure plate means positioned in surrounding relation to the male mold part within the cutting blade and having an edge engaging the seal structure. This arrangement allows
25 the seal to be pressed into the sealing interface to further enhance the sealing function.

Brief Description of the Drawings

- 7 -

FIGURE 1 is a fragmentary perspective view of the invention apparatus;

FIGURE 2 is a cross-sectional view taken on line 2-2 of FIGURE 1 and showing the mold parts in their
5 inserted disposition;

FIGURE 3 is a cross-sectional view similar to FIGURE 2 but showing the mold parts in their retracted disposition;

FIGURE 4 is a cross-sectional view taken on line
10 4-4 of FIGURE 2;

FIGURES 5A, 5B and 5C are detail views taken within the circle 5 of FIGURE 2;

FIGURE 6 is a perspective view of the female mold part;

15 FIGURE 7 is a perspective view of the male mold part; and

FIGURE 8 is a perspective view of a structural injection molded part formed utilizing the method and apparatus of the invention.

20

- 8 -

Detailed Description of the Preferred Embodiment

The invention apparatus is intended for use with a conventional press, hydraulic or otherwise, including a bed 10 and a head 12 movable toward and away from each other in known manner to actuate apparatus positioned between the head and the bed.

The invention apparatus comprises a die set 14 adapted to be positioned between bed 10 and head 12 and including a lower die set assembly 16 and an upper die set assembly 18.

Lower die set assembly 16 includes a mixing head 20, a bottom plate 22, a bottom or female mold 24, an injection nozzle 26, corner bushings 28, and stop blocks 30. Mixing head 20 includes flange portions 20a for bolting the mixing head to the upper face of press bed 10 and defines a central reaction chamber 20b opening at 20c in the upper face of the mixing head.

Bottom plate 22 has a rectangular configuration generally conforming to the configuration of mixing head 20 and bed 10 and is suitably secured to the upper face of the mixing head.

Bottom or female mold 24 is suitably and centrally secured to the upper face 22a of bottom plate 22 and defines a mold concavity 24a having a size and configuration determined by the size and configuration of the part to be formed. As best seen in Figure 6, mold 24 has an annular configuration and includes a cutting barrier in the form of an annular strip 32 positioned in an annular

- 9 -

groove on the upper face 24b of the mold in surrounding relation to mold cavity 24a. Strip 32 may be formed for example of aluminum, polyethylene, nylon, steel, brass or other appropriate material and is intended to receive a cutting edge of the cutting blade of the invention apparatus during the trimming operation.

Injection nozzle 26 is positioned in a central aperture 22b of bottom plate 22 and includes an upper end portion 26a extending upwardly through a central aperture 24c in bottom mold 24 and a lower portion 26b positioned in the opening 20c of mixing chamber 20b with the central passage 26c of the nozzle opening at its upper end in the lower wall 24d of mold cavity 24a and opening at its lower end in mixing chamber 20b so as to provide communication between mixing chamber 20b and mold cavity 24a.

Bushings 28 are provided at the four corners of bottom plate 22 and project upwardly from the top face 22a of bottom plate 22.

Stop blocks 30 project upwardly from the top face 22a of bottom plate 22 at locations intermediate the corners of the bottom plate.

Upper die assembly 18 includes a mounting plate 36, risers 38, a top plate 40, an upper or male mold 42, a male mold mounting and stop system 44, a cutting blade 46, a seal 48, a seal pressure plate assembly 50, and a material pressure plate assembly 52.

Mounting plate 36 is suitably secured as by bolting to the bottom face 12a of press head 12.

- 10 -

Risers 38 extend rigidly downwardly from mounting plate 36.

Top plate 40 is secured at its upper face 40a to the lower edges 38a of risers 38 and has a size and configuration generally conforming to bottom plate 22.

Upper or male mold 42, as best seen in Figure 7, includes a main body portion 42a, an annular ledge or lip portion 42b, and a convex lower portion 42c. Lower portion 42c is sized to fit within lower mold concavity 24a to define a mold cavity therebetween with lip or ledge 42b seating around the upper face of the concavity 24a proximate the cutting barrier 32.

Liquid ducts 58 are provided in upper and lower molds 42,24 to allow a cooling or heating liquid to be circulated through the molds to maintain a desired mold temperature.

Male mold mounting and stop system 44 includes a pair of rods 60 rigidly secured to the upper face 42d of male mold 42 and extending upwardly therefrom for passage through bores 40b in top plate 40; a pair of outriggers or beams 62 positioned above top face 40a of top plate 40; a pair of springs 64 positioned respectively in downwardly opening bores 62a provided in beam 62 and engaging the upper ends of rods 60; and rods 66 extending downwardly from the ends of beam 62 through apertures 40c in top plate 40 for stopping engagement at their lower ends 66a with the upper ends 30a of stop blocks 30.

Cutting blade 46 is in the form of a closed loop steel blade rigidly secured to the underface 40d of top

- 11 -

plate 40 in surrounding relation to main body portion 42a of male die 42. The lower edge of cutting blade 46 is beveled to define an annular cutting edge 46a.

Seal 48 is an annular elastomeric member and is positioned on the upper face 42e of lip 42b. Seal 48 includes a mounting or flange portion 48a seated on the lip upper face 42e and a main body triangular portion 48b seated on the angled outer peripheral face 42f of lip 42b and slidably engaging at its outer periphery 42g with the inner periphery 46b of cutting blade 46 proximate the lower end edge of the cutting blade. A ring member 69 is secured to male mold main body portion 42a to securely mount seal 48 with respect to the male mold.

Seal pressure plate assembly 50 includes an annular pressure plate 70 and a plurality of power cylinders 72. Pressure plate 70, as best seen in Figure 4, has an annular configuration conforming in size and shape to the annular configuration of the triangular portion 48b of seal 48 and is positioned concentrically and slidably within the inner face 46b of cutter 46. As shown, pressure plate 50 may comprise a single unitary annular member or, alternatively, may comprise a series of segments together making up the annular configuration of the pressure plate. Power cylinders 72 are positioned on the upper face 40a of top plate 40 in an annular pattern corresponding to the annular shape of pressure plate 70 and each includes a piston rod 74 extending downwardly through an aperture in top plate 40 for engagement with the upper edge 70a of annular pressure plate 70.

- 12 -

Material pressure plate assembly 52 includes an annular pressure plate 80 positioned in surrounding relation to cutting blade 46 and a plurality of power cylinders 82. Whereas pressure plate 80 may comprise a single unitary annular member, preferably, and as shown, pressure plate 80 is formed of a series of pressure plate segments 80a-j together defining an annular configuration in surrounding relation to cutting blade 46.

Power cylinders 82 are mounted on the top face 40a of top plate 40 and arranged in an annular pattern corresponding to the annular configuration of pressure plate 80. Each power cylinder 82 includes a piston rod 84 extending downwardly through an aperture in top plate 40 for securement to the top edge of pressure plate 80. As shown, a power cylinder 82 and a piston rod 84 is associated with each segment of the pressure plate so that the pressure plate segments may be individually controlled to vary the pressure applied along the lower edge 80k of the pressure plate assembly as measured around the periphery of the pressure plate.

- 13 -

Operation

With the die set in the retracted or fully open position as seen in Figure 3 and with cylinders 82 extended to move the pressure plate segments 80 to a location 5 wherein the composite lower face 80k of the pressure plate segments is below or leading the bottom or leading surface 42e of the male die, a sheet of component, reinforcing material 90 is laid over the concavity 24a of the female die 24 with peripheral portions 90a of the sheet extending 10 respectively beyond the side edge surfaces 24e, f, g, and h of the female mold. Sheet 90 may comprise, for example, one or more sheets of woven fiberglass material having a total thickness of, for example, 1/4 inch.

The press is now actuated in a manner to move 15 head 12 downwardly toward bed 10 so as to move the upper die set 18 downwardly toward the lower die set 16. As the lower faces 80a of the pressure plate segments 80 contact the upper face of sheet 90 to clamp the sheet against the annular upper face 24b of the female mold, the upper die 20 set continues downwardly and cylinders 82 are actuated in a manner to gradually retract piston rods 84 so as to maintain clamping force on sheet 90 while allowing the upper die set to continue its downward movement. As the upper die set continues downwardly as allowed by the 25 retracting movement of piston rods 84, the convexity 42c of die member 42 contacts the upper face of sheet 90 and, with continued downward movement of the upper die set, begins to move into the concavity 24a of the lower mold.

- 14 -

Since the fiberglass material of sheet 90 is essentially non-stretchable, the downward movement of convexity 42c into concavity 24a is accompanied by slippage of the component material 90 at the interface between the lower faces 80a of the pressure plate segments and the upper face of the sheet to allow the sheet to move downwardly into concavity 24a along with male mold convexity 42c. The pressure of the fluid delivered to the various cylinders 82 is selectively varied, as measured around the periphery of the annular pattern of the cylinders, to provide selectively varying force against the sheet along the annular undersurface 80a of the pressure plate segments so as to allow the sheet to move smoothly and efficiently downwardly with the convexity 42c into the cavity 24a.

This selective pressure as applied in varying degrees around the annular interface between the pressure plate segments 80 and the component material may be accomplished with a single unitary pressure plate 80 but, in most situations, is more effectively accomplished, as illustrated, by forming the pressure plate 80 of a series of pressure plates segments 80a-80j with at least one cylinder 82 associated with each segment to allow the individual segments to be individually adjusted with respect to the amount of pressure applied by that segment to the component material as the material slips between the interface of surface 80a and the upper face of the female mold for movement into concavity 24a.

- 15 -

The lower limit of movement of male mold 42 into concavity 24a is determined by engagement of the lower faces 66a of rods 66 with the upper faces of stop blocks 30. This delimited position of downward movement of male mold 42 is adjusted to provide a mold cavity 100 of desired dimensions between the convexity 42c of male mold 42 and the concavity 24a of female mold 24. The downwardly delimited stop position of the male mold also defines an annular access opening 102 between the lower annular face 42g of lip 42 and the annular upper face 24b of the female mold. Annular access opening 102 will be seen to provide access to the mold cavity 100 at a location external to the mold assembly so as to allow the sheet 90 to be positioned within the cavity 100 by the downward movement of convexity 42c into concavity 24a while allowing the edge portions 90a of the sheet to extend outwardly through access opening 102 to a location external to the mold cavity on all sides of the mold cavity.

After the male mold reaches its delimited downward position, as determined by engagement of surfaces 66a,30a, the upper die set continues to move downwardly an incremental amount, as seen by a comparison of Figures 5A and 5B, to allow the lower edge 46a of the cutting blade 46 to move downwardly through the sheet 90 and sever the sheet so as to trim the sheet to a shape conforming to the closed loop internal periphery of the cutting blade. As seen in Figure 5B, the upper die set is moved downwardly to a point where the lower sharpened edge of the cutting blade may move slightly into the material of the cutting barrier 32

- 16 -

so as to ensure a total and effective cut. The relative movement as between the male mold 42 and the remainder of the upper die set 18, including the cutting blade, is made possible by the lost motion connection provided by rods 60
5 and springs 64.

After the upper die set has completed its downward movement to the position seen in Figure 5B, cylinders 72 are actuated to extend piston rods 74 and press the lower ends of the piston rods downwardly against
10 the upper edge 70a of pressure plate 70 and thereby press the lower edge of the pressure plate against the upper edge of seal 48 so as to, as best seen in Figure 5C, tend to extrude the lower edge of triangular seal portion 48b downwardly into the interface between blade 46 and male
15 mold lip 42 so as to coact with the cutter blade to ensure that the annular edge of mold cavity 100 is effectively sealed.

Specifically, the inner face 46b of cutter blade 46 effectively precludes fluid leakage radially outwardly
20 out of cavity 100 through annular opening 102, and seal 48 effectively precludes fluid leakage upwardly out of cavity 100 between the male mold and the cutter blade.

Resin is now injected into mold cavity 100 through passage 26c of nozzle 26. The resin is injected
25 under pressure and moves upwardly through the material 90 within the cavity 100 so as to effectively and completely permeate the material 90 and totally fill the cavity 100 with resin and with the component material with movement of

- 17 -

the resin beyond the annular edge of the cavity precluded by the inner surface 46b of blade 46 and by seal 48.

The resin injected through nozzle 26 into the mold cavity is preferably a two part reaction type mixture wherein the two ingredients of the resin are mixed in chamber 20b and, during the "cream" time of the resin, the resin is injected through nozzle 26 into the mold cavity by a suitable injection mechanism in the form of a screw or the like (not shown) so as to enter the mold cavity and totally permeate the material 90 throughout the mold cavity.

Following a suitable cure time which will of course vary depending on the part being formed and the nature of the resin employed, upper die set 18 is moved upwardly by head 12 of the press to return the die set to the retracted position seen in Figure 3, whereafter the formed structural injection molded part 110 is removed from the mold cavity, with the aid of ejectors if necessary, and the invention apparatus is ready to begin another injection molding cycle. The part 110, as seen in Figure 6, comprises a bumper beam for use on a motor vehicle to support the finish facia of the bumper in the completed motor vehicle.

The invention method and apparatus will be seen to provide a simple and effective system for forming structural injection molded parts utilizing a single apparatus to perform all of the necessary steps required to form the part and allowing all of the steps of the

- 18 -

methodology to be performed in an efficient, compact and continuous manner.

Whereas a preferred embodiment of the invention has been illustrated and described in detail, it will be
5 apparent that various changes may be made in the disclosed embodiment without departing from the scope or spirit of the invention.

- 19 -

Claims

1. A method of forming a structural injection molded part comprising the steps of:

5 providing a mold assembly including a female mold part defining a concavity and a male mold part defining a convexity sized to fit within the concavity of the female mold part to define a mold cavity corresponding to the shape of the part to be molded;

10 positioning reinforcing material over the concavity of the female mold part;

moving said male mold part convexity into said female mold part concavity to position said reinforcing material in said mold cavity; and

15 injecting resin into said mold cavity to produce a structural injection molded part.

2. A method according to claim 1 and including the further step of:

20 trimming said material to the shape of the part after said material is moved into said mold cavity.

3. A method according to claim 2 wherein a closed loop cutting blade is positioned in surrounding relation to one of said mold parts and wherein:

25 said trimming step is performed by moving said cutting blade relative to said one mold part.

- 20 -

4. A method according to claim 2 wherein:
said trimming step is performed before said resin
injecting step.

5 5. A method according to claim 4 and including
the further step of:

providing a seal around the peripheral edge of
said mold cavity to preclude the escape of resin from said
mold cavity.

10

6. A method according to claim 5 wherein:
said trimming step is performed with a closed
loop cutting blade; and

15 said seal is provided proximate the inner
periphery of said cutting blade.

7. A method according to claim 6 wherein the
male mold part is positioned within the cutting blade and
defines an annular interface with the cutting blade and an
20 annular seal member is provided around said male mold part
at said interface and wherein:

said seal providing step includes pressing said
seal member into said interface following said trimming
step.

25

8. A method according to claim 1 and including
the further step of:

- 21 -

before said male mold part convexity is moved into said female mold part concavity, clamping said material around the periphery of said concavity.

5 9. A method according to claim 8 wherein the reinforcing material is substantially non-stretchable and wherein:

 said clamping step includes selectively controlling the clamping pressure to allow material to
10 selectively slip past the clamping interface to allow said male mold part convexity to move into said female mold part concavity.

 10. A method according to claim 9 wherein:

15 said clamping step includes selectively varying the clamping pressure around the clamped peripheral interface to provide a varying clamping force as measured around the clamping interface.

20 11. A method according to claim 1 wherein:

 said resin injecting step is performed by introducing resin into said mold cavity through said female mold part.

25 12. An apparatus for forming structural injection molded parts, said apparatus comprising:

 a mold assembly including a female mold part defining a concavity and a male mold part having a convexity sized to fit into the female mold part concavity;

- 22 -

means for moving said mold parts between a retracted position in which said male mold part convexity is withdrawn from said female mold part concavity and an inserted position in which said male mold part convexity is positioned within said female mold part concavity to define a mold cavity therebetween corresponding to the shape of the part to be molded and define an access opening therebetween at the periphery of said concavity providing access to said mold cavity from a location external to said mold assembly, whereby to allow a sheet of reinforcing material to be positioned over said concavity with said mold parts in their retracted positions whereafter the mold parts may be moved into their inserted positions to position the sheet within the mold cavity with edge portions thereof extending through said access opening to a location external to the mold cavity; and

means for injecting resin into said mold cavity to impregnate said sheet of reinforcing material and form a reinforced structural injection molded part.

20

13. An apparatus according to claim 12 and further including:

means for trimming said edge portions of said sheet.

25

14. An apparatus according to claim 13 wherein: said trimming means comprises a cutting blade mounted in surrounding relation to one of said mold parts.

- 23 -

15. An apparatus according to claim 14 wherein said apparatus further includes:

means mounting said one mold part for movement relative to said cutting blade.

5

16. An apparatus according to claim 12 wherein said apparatus further includes:

clamping means for clamping said edge portions of said sheet.

10

17. An apparatus according to claim 16 wherein: said clamping means comprises pressure plate means positioned in surrounding relation to said male mold part.

15

18. An apparatus according to claim 17 wherein said apparatus further includes:

means for trimming said edge portions of said sheet.

20

19. An apparatus according to claim 18 wherein: said trimming means comprises a cutting blade mounted in surrounding relation to said male mold part and within said pressure plate means.

25

20. An apparatus according to claim 12 and further including:

means for sealing said mold cavity proximate said access opening.

- 24 -

21. An apparatus according to claim 20 wherein:
said sealing means includes a seal structure
mounted in surrounding relation on said male mold part.

5 22. An apparatus according to claim 21 wherein
said apparatus further includes:
means for trimming said edge portions of said
sheet.

10 23. An apparatus according to claim 22 wherein:
said trimming means comprises a cutting blade
mounted in surrounding relation to said male mold part and
to said seal structure.

15 24. An apparatus according to claim 23 wherein:
said cutting blade is mounted for movement
relative to said male mold part to perform said trimming
step.

20 25. An apparatus according to claim 23 wherein
said apparatus further includes:
clamping means for clamping said edge portions of
said sheet.

25 26. An Apparatus according to claim 25 wherein:
said clamping means comprises pressure plate
means positioned in surrounding relation to said cutting
blade.

- 25 -

27. An apparatus according to claim 26 wherein:
said seal structure comprises an annular seal
structure mounted on the periphery of said male mold part;
and

5 said apparatus further includes further pressure
plate means positioned in surrounding relation to said male
mold part within said cutting blade and having an edge
engaging said seal structure.

10 28. An apparatus for forming structural
injection molded parts comprising:

 a mold assembly including a female mold part
defining a concavity and a male mold part defining a
convexity sized to fit into said female mold part concavity
15 to define a mold cavity therebetween corresponding to the
shape of the part to be molded; and

 a closed loop cutting blade positioned in
surrounding relation to said male mold part and defining an
annular cutting edge for coaction with an annular cutting
20 surface defined on said female mold part in surrounding
relation to said concavity.

29. An apparatus according to claim 28 wherein
said apparatus further includes:

25 an annular seal positioned in surrounding
relation to said male mold part within said cutting blade.

30. An apparatus according to claim 29 wherein
said apparatus further includes:

- 26 -

annular pressure plate means positioned in surrounding relation to said cutting blade.

31. A die set for use in forming a structural injection molded part, said die set comprising:

a top plate;

an upper mold part positioned beneath said top plate and defining a molding surface on its lower face;

a bottom plate;

a bottom mold part positioned on said bottom plate and defining a molding surface on its upper face coacting with said upper mold part molding surface to define a mold cavity;

an annular cutter blade carried by said top plate in surrounding relation to said male mold part; and

means allowing said cutter blade to move relative to said upper mold part.

32. An apparatus for forming structural injection molded parts, said apparatus comprising:

a mold assembly including a female mold part defining a concavity and a male mold part having a convexity sized to fit into the female mold part concavity;

means for moving said mold parts between a retracted position in which male mold part convexity is withdrawn from said female mold part concavity and an inserted position in which said male mold part convexity is positioned within said female mold part concavity to define a mold cavity therebetween corresponding to the shape of

- 27 -

the part to be molded and define an access opening therebetween at the periphery of said concavity providing access to said mold cavity from a location external to said mold assembly, whereby to allow a sheet of reinforcing material to be positioned over said concavity with said mold parts in their retracted positions whereafter the mold parts may be moved into their inserted positions to position the sheet within the mold cavity with edge portions thereof extending through said access opening to locations external to the mold cavity; and

an annular cutter blade positioned in surrounding relation to one of said mold parts and mounted for movement relative to said one mold part to trim the edge portions of the material positioned within the mold cavity.

15

33. An apparatus according to claim 32 wherein said apparatus further includes:

means for injecting resin into said mold cavity to impregnate said sheet of reinforcing material and form a reinforced structural injection molded part.

20

34. An apparatus according to claim 33 wherein: said annular cutter blade is positioned in surrounding relation to said male mold part; and

said injecting means comprises means for injecting resin into said mold cavity through said female mold part.

25

1/5

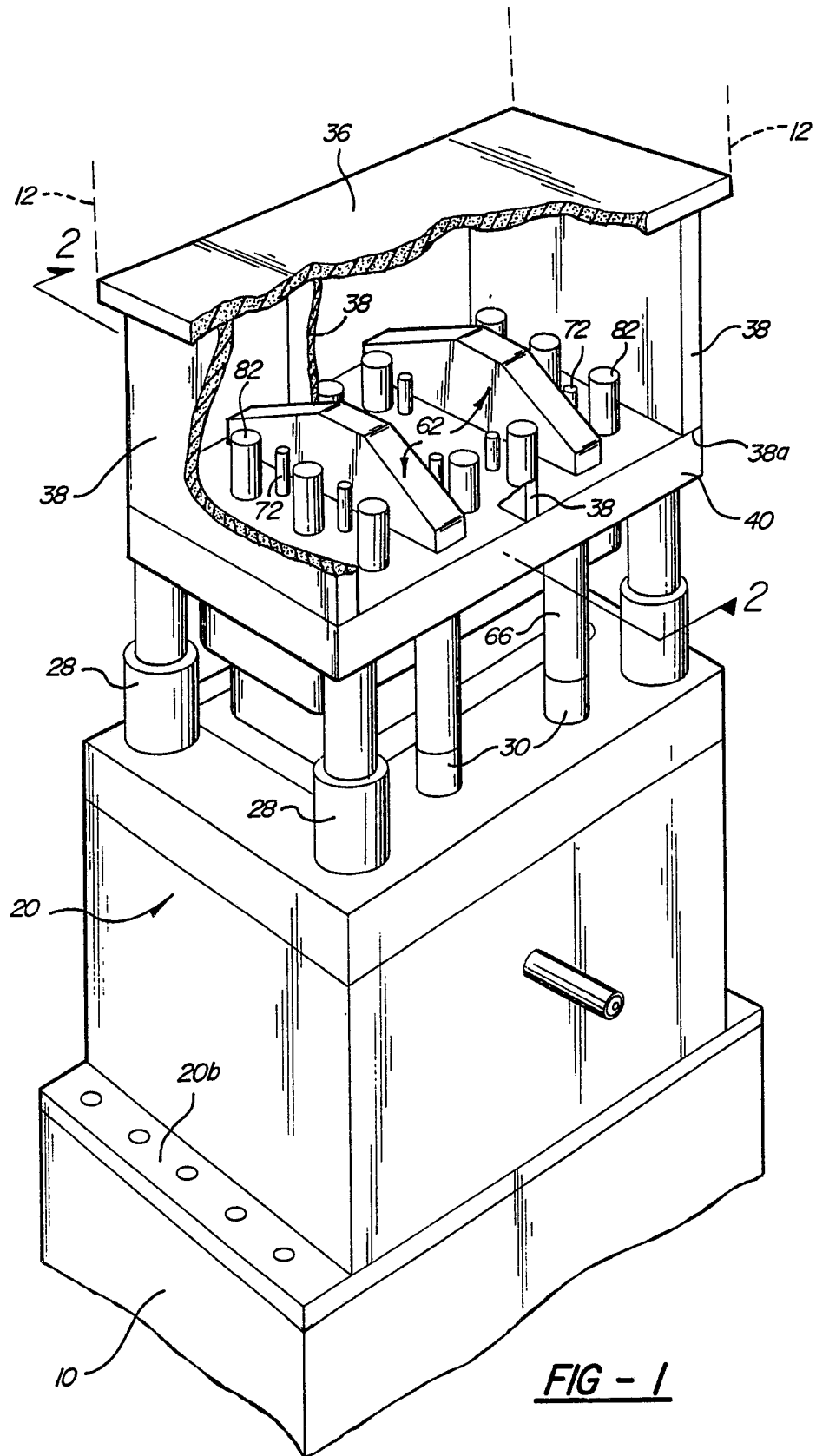

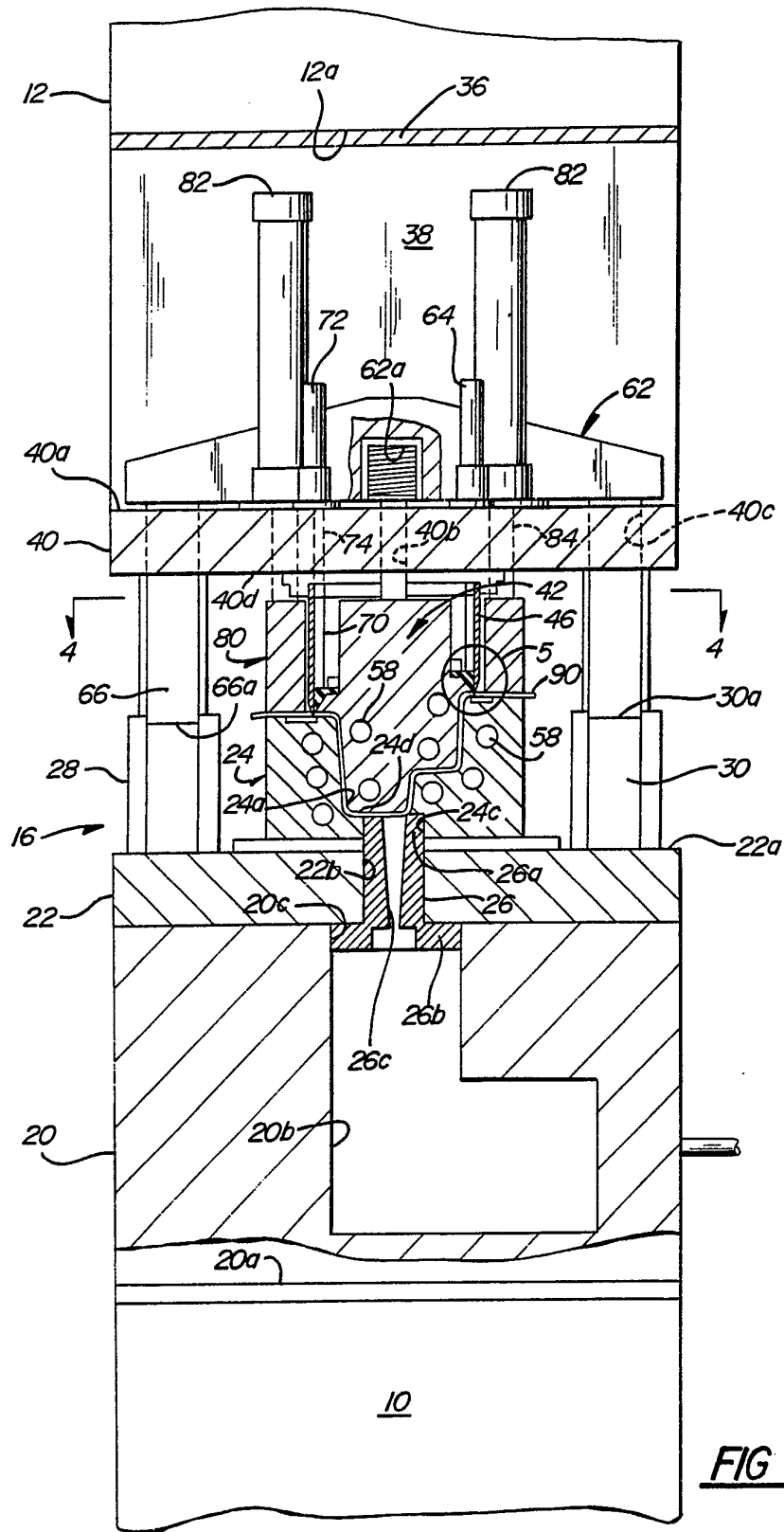
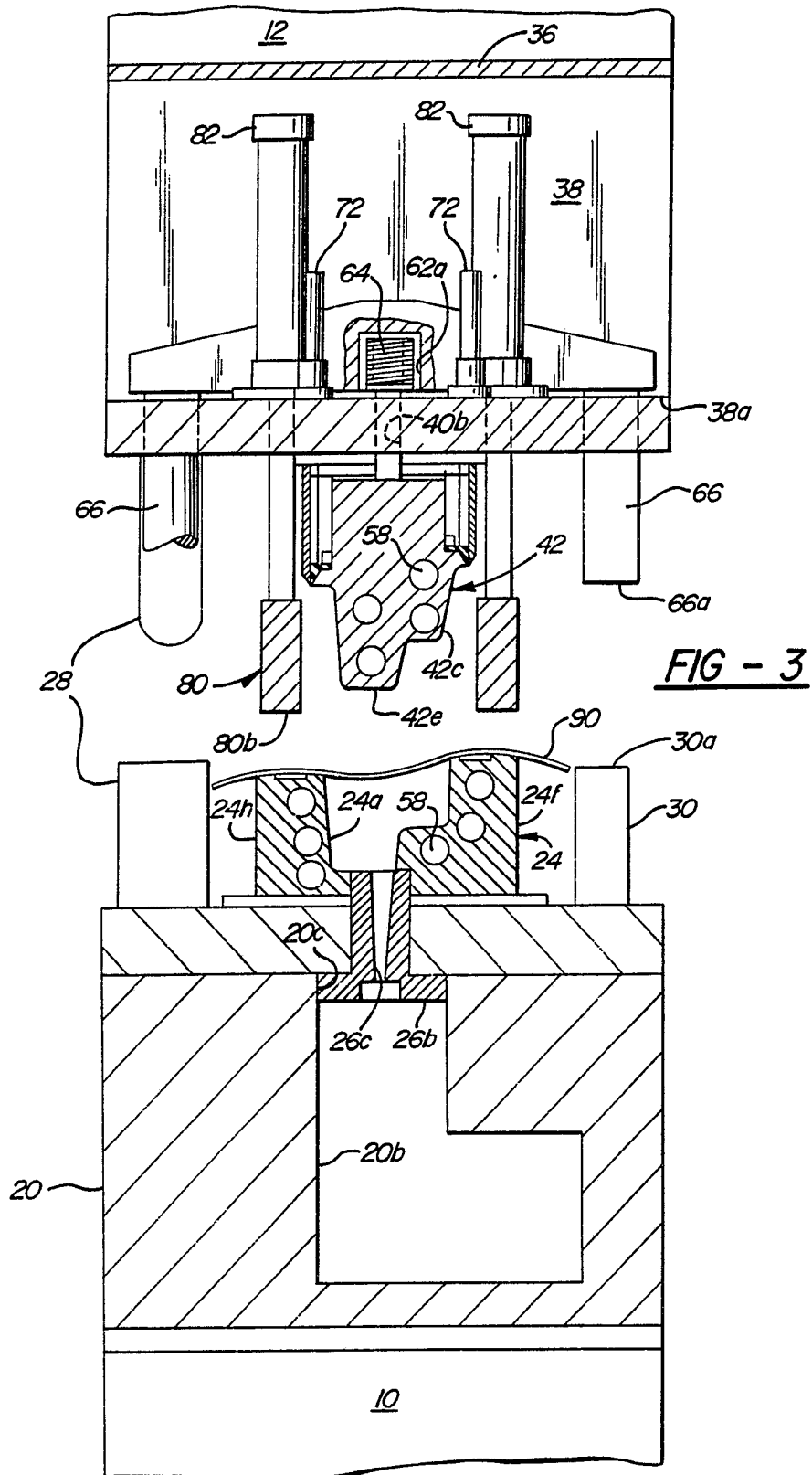

FIG - 2



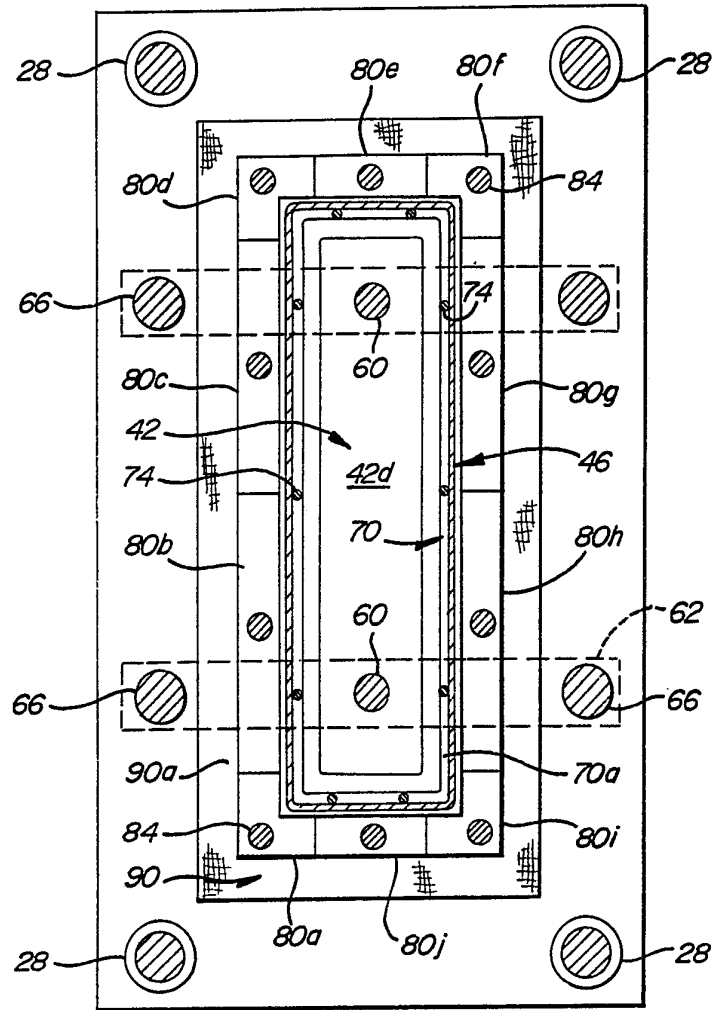

FIG - 4

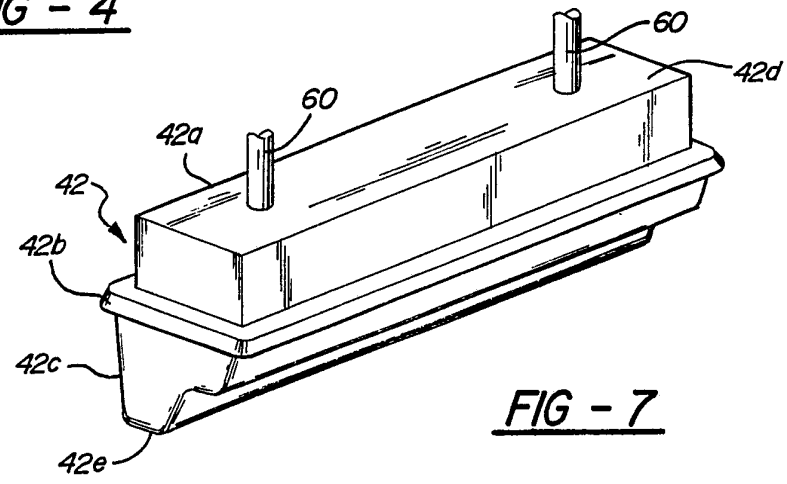

FIG - 7

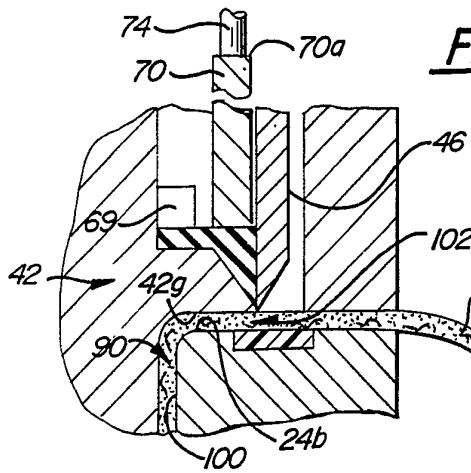

FIG - 5A

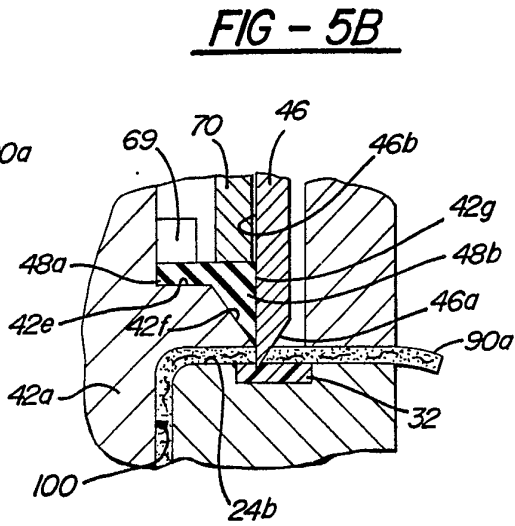

FIG - 5B

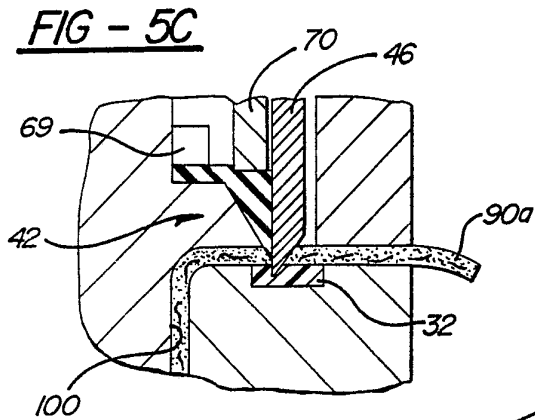

FIG - 5C

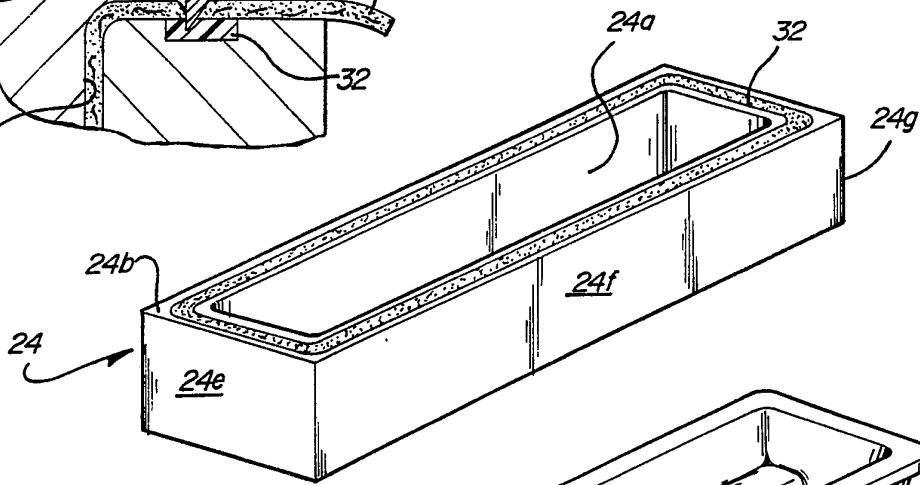

FIG - 6

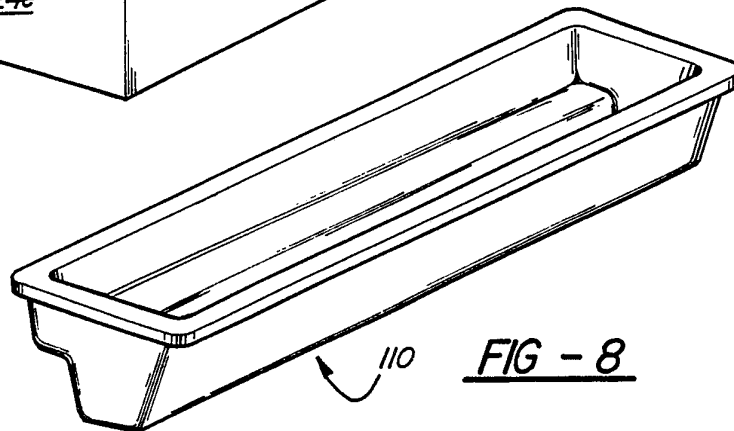
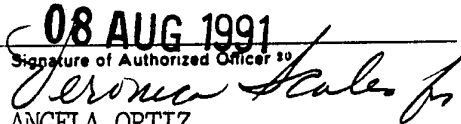

FIG - 8

INTERNATIONAL SEARCH REPORT

International Application No PCT/US91/02903

I. CLASSIFICATION OF SUBJECT MATTER (if several classification symbols apply, indicate all) ³		
According to International Patent Classification (IPC) or to both National Classification and IPC		
IPC(5): B29C 43/18 B29C 55/20 B28B 11/12		
U.S. CL. 264/163,257,323 425/112,292, Dig.18		
II. FIELDS SEARCHED		
Minimum Documentation Searched ⁴		
Classification System	Classification Symbols	
US	264/153,163,257,324,323 425/112, Dig.8	
Documentation Searched other than Minimum Documentation to the Extent that such Documents are Included in the Fields Searched ⁵		
III. DOCUMENTS CONSIDERED TO BE RELEVANT ^{1,4}		
Category ⁶	Citation of Document, ^{1,7} with indication, where appropriate, of the relevant passages ^{1,7}	Relevant to Claim No. ^{1,8}
Y	US, A, 2,849,026 (TAPLIN) 26 AUGUST 1958 See entire document	1-34
Y	US, A, 3,028,284 (REEVES) 03 APRIL 1962 See entire document	1-34
Y	US, A, 3,520,750 (HSIN ET AL) 14 JULY 1970 See entire document	1-34
Y	US, A, 3,577,594 (AL-ROY) 04 MAY 1971 See entire document	1-34
Y	US, A, 3,584,109 (MEADORS ET AL) 08 JUNE 1971 See entire document	1-34
Y	US, A, 3,726,953 (JONES ET AL) 10 APRIL 1973 See entire document	1-34
Y	US, A, 3,755,522 (JOPE ET AL) 28 AUGUST 1973 See entire document	1-34
Y	US, a, 3,979,174 (HILLMAN ET AL) 07 SEPTEMBER 1976 See entire document	1-34
<p>⁹ * Special categories of cited documents: ^{1,9}</p> <p>"A" document defining the general state of the art which is not considered to be of particular relevance</p> <p>"E" earlier document but published on or after the international filing date</p> <p>"L" document which may throw doubts on priority claim(s) or which is cited to establish the publication date of another citation or other special reason (as specified)</p> <p>"O" document referring to an oral disclosure, use, exhibition or other means</p> <p>"P" document published prior to the international filing date but later than the priority date claimed</p> <p>"T" later document published after the international filing date or priority date and not in conflict with the application but cited to understand the principle or theory underlying the invention</p> <p>"X" document of particular relevance; the claimed invention cannot be considered novel or cannot be considered to involve an inventive step</p> <p>"Y" document of particular relevance; the claimed invention cannot be considered to involve an inventive step when the document is combined with one or more other such documents, such combination being obvious to a person skilled in the art.</p> <p>"&" document member of the same patent family</p>		
IV. CERTIFICATION		
Date of the Actual Completion of the International Search ²	Date of Mailing of this International Search Report ³	
12 JULY 1991	08 AUG 1991	
International Searching Authority ¹	Signature of Authorized Officer ¹⁰	
ISA/US	 ANGELA ORTIZ	

III. DOCUMENTS CONSIDERED TO BE RELEVANT (CONTINUED FROM THE SECOND SHEET)		
Category *	Citation of Document, ¹⁶ with indication, where appropriate, of the relevant passages ¹⁷	Relevant to Claim No ¹⁸
Y	US, A, 4,216,184 (THOMAS) 05 AUGUST 1980 See entire document	1-34
Y	US, A, 4,459,092 (HATAKEYAMA) 10 JULY 1984 See entire document	1-34