

[54] CONTACT PACER TIMER

[76] Inventor: Robert O. Greber, 10144 Dunbarton Dr., El Paso, Tex. 79925

[22] Filed: Dec. 26, 1973

[21] Appl. No.: 427,817

[52] U.S. Cl. .... 340/323; 340/321; 340/384 E

[51] Int. Cl. .... G08b 23/00

[58] Field of Search..... 340/323, 309.1, 279; 272/4, 5; 35/29 R, 29 B; 58/38, 145 A, 130 E, 152

[56]

References Cited

UNITED STATES PATENTS

3,119,610	1/1964	Clinton .....	35/29 R
3,492,582	1/1970	Heywood .....	35/29 R
3,540,344	11/1970	Veech .....	58/130 E

Primary Examiner—Thomas B. Habecker

[57] ABSTRACT

A contact pacer timer intended to be worn about a portion of an individual's body and generated time related pacing signals of a frequency settable by the individual for use in pacing the body movement of the individual such as for jogging, walking and the like, the device including an electrical circuit defining a multi-vibrator which is manually settable by a time-frequency selector to govern the output frequency of the circuit, and an acoustical convertor for amplifying and converting the vibrating output to an audible signal which is audible to the individual wearing the device.

1 Claim, 3 Drawing Figures

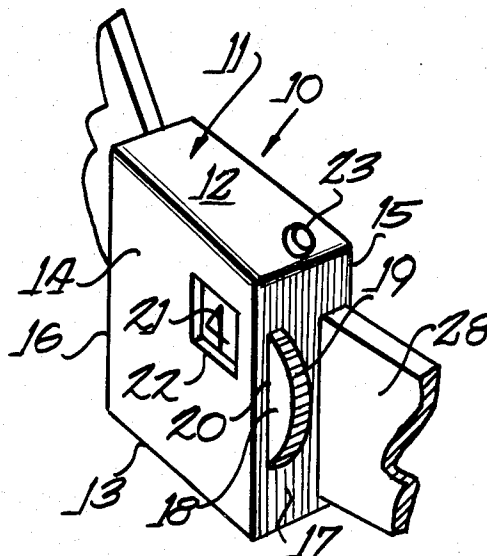

Fig. 1

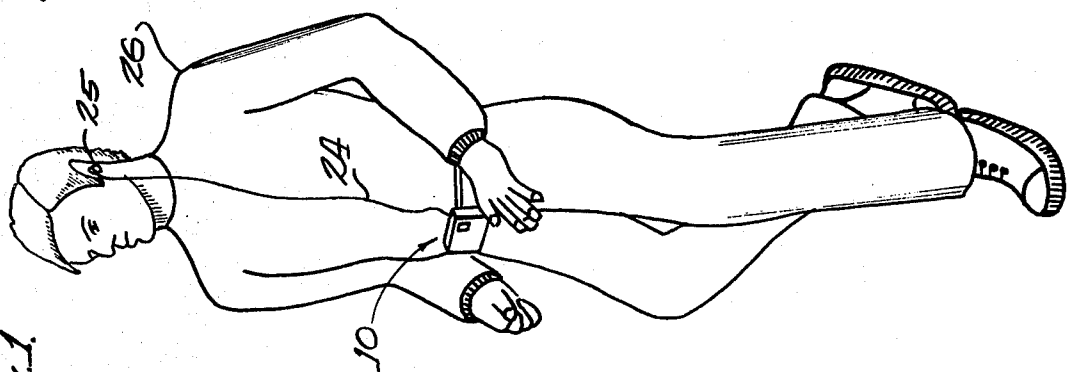

Fig. 2

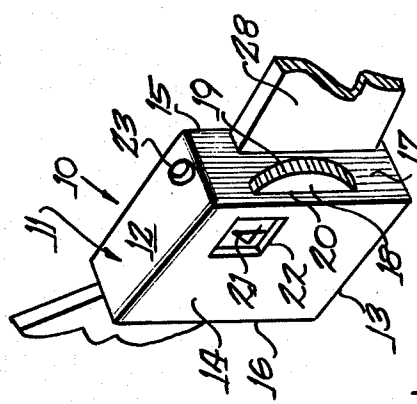
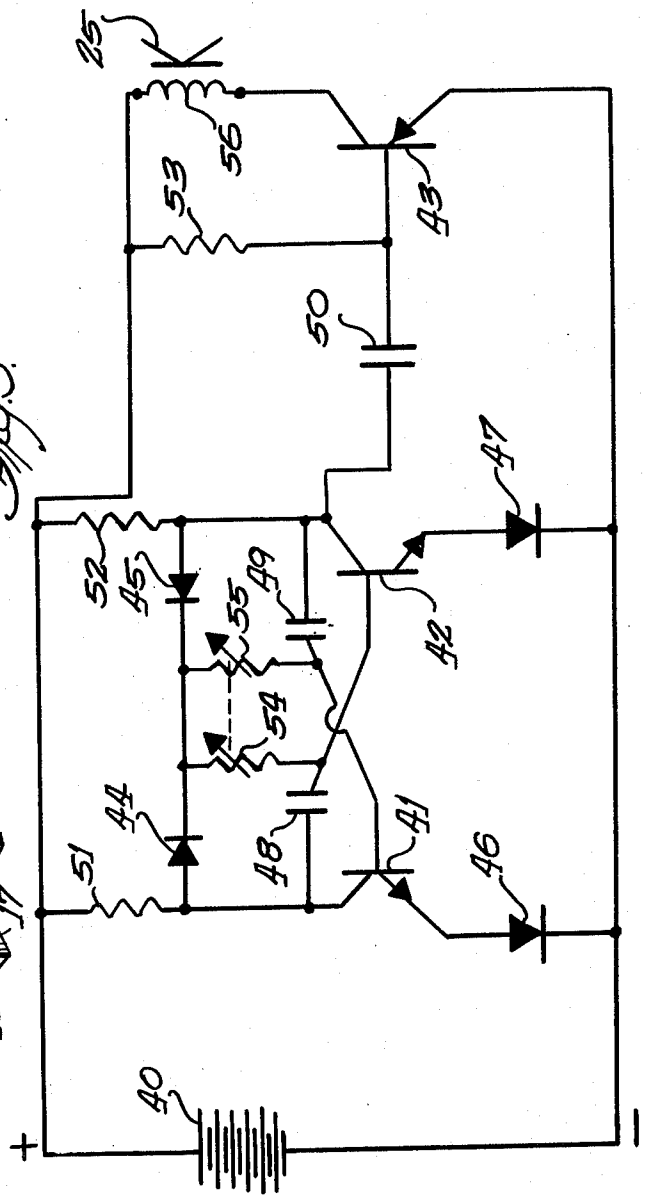

Fig. 3



## CONTACT PACER TIMER

## BACKGROUND OF THE INVENTION

## 1. Field of the Invention

This invention relates generally to timing and pacing devices and more particularly to a novel electronic pacer timer intended to be worn about a portion of an individual's body and which is settable to provide pace signals for the pacing of an individual's body movement in jogging, walking and the like.

## 2. Description of the Prior Art

In many sports and activities it is desired that an individual pace or time himself for the smoothest body movement providing maximum durability and most efficient use of the body. A problem associated with conventional pacer-timer apparatus available in the prior art is that they are usually too large to be conveniently carried by an individual during the pacing operation of running, jogging, walking and the like, or if conveniently carried they require substantially constant visibility to the individual to achieve the desired pacing effect, such as the use of a stop watch which requires that the individual constantly watch and time the same in conjunction with the body movements to obtain the desired pacing affect.

## SUMMARY OF THE INVENTION

The present invention recognizes the problem of an individual wishing to pace their body movements without having to maintain constant visible vigilance of the pacing apparatus, such as a stop watch and the like, with the present invention providing a novel solution thereto consisting of a compact electronic pacer timing device readily worn about a portion of an individual's body and which provides an audible output of a frequency settable by the individual to obtain a pacing signal for the individual to use in pace setting of the individual's body movements.

It is a feature of the present invention to provide a lightweight, compact and efficient pacer-timer adapted to be worn by an individual and to provide audible pacing signals for use by the individual in pacing their body movements.

Still a further feature of the present invention provides a pacer-timer which is relatively inexpensive to manufacture due to its simplicity of construction; one which is possessed of few parts and which therefore is unlikely to get out of order; one requiring a minimum of maintenance and supervision; one which is rugged and durable in construction and which therefore may be guaranteed by the manufacturer to withstand many years of intended usage; one which is easy to use and reliable and efficient in operation; one which is readily adjustable by the individual while in use in a manner to change the pace at any desired time without requiring visible vigilance to make such changes; and one which is well adapted to perform the services required of it are among the desirable features and advantages of the present invention.

Other features and advantages of this invention will be apparent during the course of the following description.

## BRIEF DESCRIPTION OF THE DRAWINGS

In the accompanying drawings forming a part of this specification, and in which like reference characters are employed to designate like parts throughout the same:

FIG. 1 is a perspective view of an individual wearing the pacer-timer device of the present invention;

FIG. 2 is a perspective view of the pacer-timer device; and

FIG. 3 is an electrical schematic diagram of the circuit of the pacer-timer device.

## DESCRIPTION OF THE PREFERRED EMBODIMENT

Referring now to the drawings in detail there is illustrated a preferred form of a pacer-timer device constructed in accordance with the principles of the present invention and designated generally in its entirety by the reference numeral 10. The pacer-timer device 10 includes a hollow box-like housing 11 having a top surface 12, a bottom surface 13, a front surface 14, a back surface 15, and opposed side surfaces 16 and 17. A substantially flat circular disc 18 is mounted in the housing 11 for rotation about its axis and is provided with a knurled circumferal edge 19, a portion of the disc projecting through a slot 20 in side wall 17 in a manner to be engaged by an individual's finger in a manner to effect the rotation of the disc about its axis. The face surface of the disc 18 adjacent the interior surface of front wall 14 is provided with a plurality of indicating numerals 21 disposed sequentially about the circumference thereof and adapted to be selectively brought into orientation with a rectangular opening 22 provided in housing face surface 14, such indicating numerals designating positions of the disc 18 for reference by the individual in selecting a desired pacer output from the pacer-timer device 10 as will be later described. An electrical earphone jack 23 is mounted in housing top surface 12 and is adapted to receive the plug end of an electrical wire 24 having an earphone 25 mounted at the opposite end thereof and adapted to be worn in the ear of an individual 26 when using the pacer-timer device 10.

While it is to be understood that the pacer-timer device may be worn about any portion of the body of the individual 26, such as about the waist as shown, it is accordingly provided with a flexible strap 28 mounted to housing 11 and projecting from opposite side walls 16 and 17 and having associated therewith required suitable fasteners, such as buckles and the like, for retaining the device to the individual's body.

Referring now to FIG. 3 it is seen that the device comprises a battery 40 which may be of the nine to twelve volt variety; three bipolar junction transistors 41, 42 and 43, four diodes 44, 45, 46 and 47; three capacitors 48, 49 and 50; three resistors 51, 52 and 53; two interconnected variable adjustable resistors 54 and 55, and the coil 56 of the earphone 25. The transistors 41 and 42 are of the NPN type with the transistor 43 being of the PNP type.

In the preferred embodiment, resistor 51 is 1,200 ohms, resistor 52 is 1,500 ohms, resistor 53 is 8,200 ohms, resistors R3 and R4 are coupled together for adjustability to disc 18 with each of these resistors being adjustable between 33,000 ohms to 50,000 ohms, ca-

capacitor 48 is 15 microfarads, capacitor 49 is 15 microfarads, and capacitor 50 is 1 microfarad.

Resistor 51 has one end connected to the positive terminal of battery 40, the opposite end being connected to the base of diode 44 and to one end of capacitor 48 and to the collector of transistor 41. The emitter of transistor 41 is connected to the base of diode 46 with the opposite end of the diode connected to the negative terminal of battery 40. The resistor 52 has one end connected to the positive terminal of battery 40, the opposite end connected to the base of diode 45 and one end of capacitor 49 and to the collector of transistor 42. The emitter of transistor 42 is connected to the base of diode 47 with the opposite end of diode 47 being connected to the negative terminal of battery 40. The opposite ends of diodes 44 and 45 are connected together. One end of variable resistor 54 is connected to the junction between diodes 44 and 45, the opposite end of resistor 54 connected to the opposite end of capacitor 48 and also to the base of transistor 42. Similarly, one end of variable resistor 55 is connected to the junction between diodes 44 and 45 with the opposite end connected to the opposite end of capacitor 49 and to the base of transistor 41. The transistor 43 has its emitter connected to the negative terminal of battery 40 with its collector connected to one end of earphone coil 56, the opposite end of the earphone coil being connected to the positive terminal of the battery 40. The base of transistor 43 is connected through capacitor 50 to the collector of transistor 42. The resistor 43 has one end connected to the positive terminal of battery 40 with the opposite end connected to the base of transistor 43 and serves as a bias resistor.

The transistors 41 and 42 and circuitry associated therewith define a multi-vibrator circuit having energy pulse output ranging from between 0.4 to 3 seconds with the resistors 54 and 55 connected in the circuit to adjust the pulse timing thereof to any selected timing within the aforementioned range. The output of the multi-vibrator circuit is coupled through capacitor 50 to transistor 43 where it is amplified to generate pulses through earphone coil 56 resulting in audible pulsating sounds at earphone 25.

An individual wearing the pacer-timer device 10 may thus select the desired pulse output as to the frequency of the same, or in other words, as to the duration of time between pulses purred in earphone 25, the individual using the same to pace his respective body movements for jogging, walking, running and the like.

It is to be understood that the form of this invention herewith shown and described is to be taken as a preferred example of the same, and that this invention is not to be limited to the exact arrangement of parts shown in the accompanying drawings or described in this specification as various changes in the details of construction as to shape, size, and arrangement of component parts may be resorted to without departing from the spirit of the invention, the scope of the novel concepts thereof, or the scope of the sub-joined claims.

Having thus described the invention, what is claimed is:

1. A pacer-timer device intended to be worn about a portion of an individual's body to provide audible pacing signals to the individual for pacing of the individual's body movements in jogging, walking and running, the device comprising, in combination:

a housing of a rectangular hollow box-like configuration having a flat vertical front surface, a flat vertical back surface, a flat horizontal top surface, a flat horizontal bottom surface, and opposed vertically extending flat side wall surfaces;

a slot extending longitudinally through said opposed side wall surfaces adjacent said back wall surface and opening out of said side wall surfaces;

an elongated flat rectangularly configured flexible strip like belt of a cross-sectional area to pass freely through said slots of said housing side wall surfaces, said belt intended to pass about an individual's waist for adjustably retaining said housing to the individual's body;

an earphone intended to be worn in an individual's ear and having an electrical cord extending outwardly therefrom;

an earphone jack disposed in said housing top surface adapted to have said earphone cord electrically connected thereto;

a rectangular opening provided in said housing front wall surface and opening into said housing interior;

a slot provided in one of said side wall surfaces adjacentmost said front wall opening and disposed parallel to and adjacent said front wall surface;

a flat circular disc member having a knurled circumferential edge and rotatively affixed about its axis interiorly of said housing to have a face surface thereof disposed rearwardly of said front surface opening and to have a portion thereof projecting outwardly of said housing interior through said slot adjacent said front wall surface to be readily engaged about its circumference by an individual's finger to effect manual rotation of said disc;

a plurality of numerically increasing indicia in the form of indicating numerals sequentially arranged on said front surface of said disc spaced equally about the circumference thereof in positions to be selectively oriented with said front surface opening upon rotation of said disc for visual indication of the relative position of said disc about its axis to an individual wearing said housing;

a source of electrical energy provided by a battery mounted in said housing; an electrical circuit disposed within said housing interior to provide an electrical signal output in the form of timing impulses to said earphone of a selected frequency range, said electrical circuit including a first and second transistor of the NPN type, a third transistor of the PNP type, a first through fourth diode, a first through third capacitor, a first through third fixed resistor, a first variable resistor, a second variable resistor, said first and second transistors defining a multi-vibrator circuit in conjunction with associated ones of said components to provide an output signal of pulses selectable in frequency in the range of from 0.4 seconds to 3.0 seconds, said third transistor receiving said output signal and amplifying the same to energize said earphone coil to provide audible signals in said earphone varying in accord with said output signal; and

said disc being manually connected to said first and said second variable resistors with rotation of said disc varying the resistance of said variable resistors to effect the tuning of the multi-vibrator circuit in a manner to select the desired frequency output signals.