

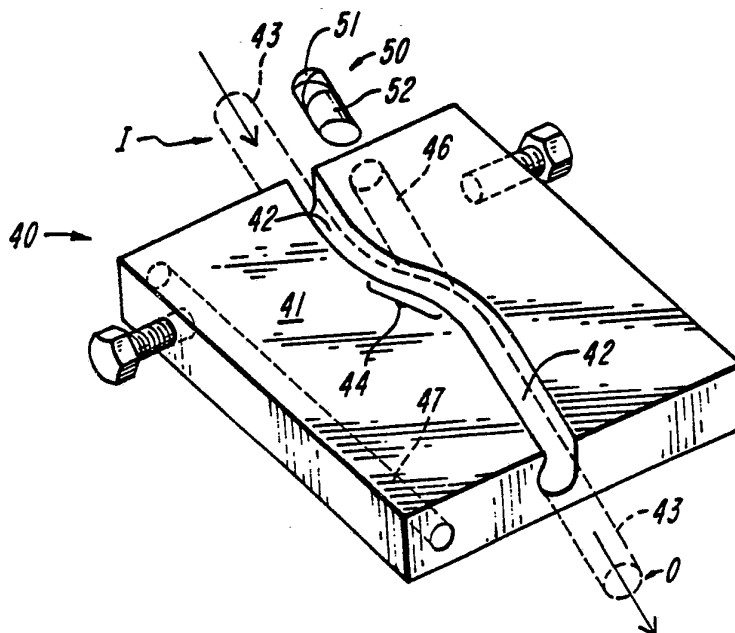

INTERNATIONAL APPLICATION PUBLISHED UNDER THE PATENT COOPERATION TREATY (PCT)

| | | |
|--|------------------|---|
| <p>(51) International Patent Classification⁵ : G01F 1/66</p> | <p>A1</p> | <p>(11) International Publication Number: WO 92/00507 (43) International Publication Date: 9 January 1992 (09.01.92)</p> |
| <p>(21) International Application Number: PCT/US91/04563 (22) International Filing Date: 26 June 1991 (26.06.91) (30) Priority data: 546,586 29 June 1990 (29.06.90) US 670,702 18 March 1991 (18.03.91) US (71) Applicant: PANAMETRICS, INC. [US/US]; 220 Crescent Street, Waltham, MA 02154 (US). (72) Inventor: LYNNWORTH, Lawrence, C. ; 77 Graymore Road, Waltham, MA 02154 (US). (74) Agents: FALKOFF, Michael, I. et al.; Lahive & Cockfield, 60 State Street, Boston, MA 02109 (US).</p> | | <p>(81) Designated States: AT (European patent), BE (European patent), CH (European patent), DE (European patent), DK (European patent), ES (European patent), FR (European patent), GB (European patent), GR (European patent), IT (European patent), JP, LU (European patent), NL (European patent), SE (European patent). Published <i>With international search report.</i></p> |

(54) Title: IMPROVED FLOW MEASUREMENT SYSTEM



(57) Abstract

A block (41) secures a conduit (43) in a channel (42) and positions at least one transducer (50) so acoustic signals travel along a precisely defined path through a flowing fluid. For small tubes, two transducers (72, 73) are coupled to a tube and launch acoustic interrogation signals along an axial path within the tube. For larger conduits, two transducers (420, 430) launch oblique signals which follow a zig-zag path through the fluid, reflecting off an inner wall of the conduit. A transducer mounting includes a plurality of massive elements placed in the acoustic propagation path to remove crosstalk. In a preferred embodiment, the elements are rings (10, 11), which are attached to, or are machined from, a thick cylinder to leave a thin-walled cylinder (14) that holds a transducer (220) off from a conduit (4a) wall. In one embodiment, a thick-walled tube (230) with radially oriented slots (232) constitutes the transducer mounting structure.

FOR THE PURPOSES OF INFORMATION ONLY

Codes used to identify States party to the PCT on the front pages of pamphlets publishing international applications under the PCT.

| | | | | | |
|----|--------------------------|----|--|----|--------------------------|
| AT | Austria | ES | Spain | MG | Madagascar |
| AU | Australia | FI | Finland | ML | Mali |
| BB | Barbados | FR | France | MN | Mongolia |
| BE | Belgium | GA | Gabon | MR | Mauritania |
| BF | Burkina Faso | GB | United Kingdom | MW | Malawi |
| BG | Bulgaria | GN | Guinea | NL | Netherlands |
| BJ | Benin | GR | Greece | NO | Norway |
| BR | Brazil | HU | Hungary | PL | Poland |
| CA | Canada | IT | Italy | RO | Romania |
| CF | Central African Republic | JP | Japan | SD | Sudan |
| CG | Congo | KP | Democratic People's Republic of Korea | SE | Sweden |
| CH | Switzerland | KR | Republic of Korea | SN | Senegal |
| CI | Côte d'Ivoire | LJ | Liechtenstein | SU | Soviet Union |
| CM | Cameroon | LK | Sri Lanka | TD | Chad |
| CS | Czechoslovakia | LU | Luxembourg | TG | Togo |
| DE | Germany | MC | Monaco | US | United States of America |
| DK | Denmark | | | | |

IMPROVED FLOW MEASUREMENT SYSTEM

5 The present invention relates to measurement
of the flow or flow velocity of a fluid moving in a
conduit, and more particularly relates to such
measurement performed by propagating ultrasonic
signals through the flowing fluid and by detecting
10 characteristics of the transit time and amplitude of
the signals so propagated. Typically, the difference
in propagation time between upstream- and
downstream-directed signals is detected. This
difference is strictly proportional to the effective
15 path length over which the signal is propagated in
the flowing fluid. Prior art ultrasonic flow
measurement systems have therefore sought to provide
for the placement of transducers in relation to the
conduit and flow path, so as to achieve a
20 sufficiently long signal propagation path with an
effective degree of alignment for signal propagation
and detection efficiency.

For larger conduits, e.g., pipes having a
25 diameter of ten centimeters or more, an effective
path length for measuring many fluids of interest is
provided by a set of transducers mounted on
strap-down V-blocks or wedges which launch and
receive ultrasonic signals along a folded or diagonal
30 path that passes or is reflected obliquely across
fluid flowing axially within the pipe. Refractive

effects occur as the ultrasonic signal passes between the transducer wedge and the pipe wall, and between the pipe wall and the flowing fluid, so the spacing of the strap-down transducers in such a system must
5 be set to align the transducers along a propagation path, and the path length is then calculated from the transducer spacing and pipe dimensions. The use in this manner of strap-down external transducers on larger conduits can provide an effective flow
10 interrogation path, but requires set-up and calibration for each particular size pipe.

With smaller conduits, below several centimeters diameter, and particularly below one
15 centimeter diameter, and especially when the conduit is metallic, diagonal interrogation with non-wetted or external transducers, if feasible, would tend to suffer from poorly defined propagation paths and crosstalk. In addition a very fine time resolution,
20 e.g., several picoseconds to perhaps tens of picoseconds, would be necessary to extract velocity-related information. Flow in smaller conduits is therefore usually measured in a different manner, by splicing a longer-path calibrated flowcell
25 into the flow line, and measuring flow in the flowcell. This may be done, for example, by providing an axial flow tube connected by T-fittings at its ends to the flow inlet and outlet, with a transducer mounted in each T-fitting to launch and
30 receive energy axially along the flow tube. With such constructions, however, the splice regions, e.g., T-fittings, create flow irregularities at the ends of the flowcell, and create regions where

sediment or gas may collect. Flow velocity is therefore determined only after correcting the actual transducer spacing L to determine an effective flow measurement path. Thus, not only does this require a
5 special flow segment to be inserted into the flow line, but individual calibration or correction of flow path parameters may be required.

The present invention also relates to
10 ultrasonic measurement systems wherein the medium has a low density, such as a gaseous medium, and wherein the size of the conduit or the signal path length through the medium raise considerations of crosstalk.

15 In these circumstances, the amount of signal energy which can be received through the medium is relatively small. Furthermore, because the signal propagates through the gas with a velocity difference from its propagation velocity through the solid
20 structure of the conduit, it can be difficult to find a suitable timing window in which the received signal can be dependably distinguished from ringing or other energy propagated directly through the conduit walls.

25 To some extent the problem of signal strength can be addressed by appropriate impedance matching and the use of a large-area diaphragm to couple the crystal to the medium. However, suitable isolation remains a problem.

Accordingly it is desirable to provide a simplified and effective flow measurement system adaptable to pipes and small diameter conduits. It is further desirable to provide a flow measurement system with enhanced transducer isolation.

Summary of the Invention

It is an object of the invention to provide a flow measurement system which non-invasively attaches to a conduit.

It is another object of the invention to provide a flow measurement system with an effective ultrasonic path through a small diameter conduit.

It is another object of the invention to provide a flow measurement unit which quickly and releasably attaches to an existing conduit.

20

It is another object of the invention to provide a flow measurement system having improved transducer isolation and freedom from ringing.

25 These and other features are achieved according to the invention in a flow measurement system wherein a block is closely fitted about a conduit and secures both the conduit and at least one transducer in precise alignment to define an ultrasonic interrogation path.

30

In accordance with one aspect of the invention, a first end block secures and orients a conduit with relation to a transducer in a streamlined curve such that signals from the
5 transducer are coupled along an axial flow path within the conduit. A second, similar end block and transducer arrangement attaches to a downstream portion of the conduit and completes the assembly. The two transducers face each other, and each is
10 capable of launching and receiving signals along the path. This provides an axial interrogation path capable of extremely fine velocity resolution using relatively coarse time base signal processing. Flexible and rigid conduits may be accurately
15 interrogated without invasive plumbing or fixturing.

In accordance with another aspect of the invention a body or housing having a channel therein resiliently snaps onto a conduit and secures a pair
20 of transducers against the conduit in precisely defined positions to launch and receive counterpropagating acoustic signals. The signals are propagated along diagonal interrogation paths. In various embodiments, the body includes a plurality of
25 different contact members which may be adjustably located to hold each of a range of different size conduits on center in the channel, and means for repositioning the transducers at a fixed number of discrete locations corresponding to the different
30 size conduits centered by the contact members. The channel is open on one side, allowing the housing to snap on to conduits that are highly obstructed or are accessible from one direction only.

For signal enhancement in accordance with another aspect of the present invention, a transducer is mounted in a housing or vessel to propagate signals along a gas interrogation path, and a
5 plurality of massive elements are placed between transmitting and receiving transducers in the acoustic propagation path through the solid body of the housing or vessel.

10 In a preferred embodiment of this aspect, the elements are rings, which are placed within a thin-walled cylinder that holds the transducer off from a conduit wall. Preferably the rings are closely spaced or even contiguous, but contact each
15 other only along a small point-like region, so that substantially all acoustic energy flows to or from each ring via the thin walled stand-off. In one embodiment, a thick-walled tube is formed with plural radially oriented slots to yield an equivalent
20 structure of alternating masses or rings. In a related embodiment, inner and outer thick-walled tubes are so formed with external and internal grooves, respectively, and are joined at one end to provide a longer damping path.

25

Brief Description of the Drawings

These and other features of the invention will be understood from the present description,
30 understood in light of the prior art and the claims appended hereto, together with the drawings, wherein

Figures 1A and 1B illustrate prior art flow measurement systems;

Figure 2 illustrates one embodiment of a system according to the present invention;

Figure 2A-2C illustrate details of transducer coupling in the system of Figure 2;

10 Figure 3 illustrates another transducer coupling in a system according to the present invention;

Figures 4 and 5 illustrate two-piece and one-piece flow measurement systems according to the invention;

Figure 6 illustrates a guided wave embodiment of the invention;

20

Figures 7, 7A - 7F illustrate details of a flowcell embodiment of the invention and related snap-on transducer blocks;

25 Figures 8, 8A are graphs of flow measurement performed with systems of the invention;

Figure 9 illustrates a snap-on transducer assembly for larger conduits;

30

Figures 10-14D illustrate alternative constructions of a snap-on transducer assembly similar to that shown in Figure 9;

Figures 15, 16 illustrate multi-channel or multimode systems;

Figure 15A illustrates a gas flow sensor isolation system;

Figure 17 shows a cross-sectional view of another transducer assembly in accordance with one aspect of the present invention;

10

Figure 18 shows the assembly of Figure 17 in a high temperature mounting;

Figure 19 shows an embodiment of the invention adapted to be removably placed in a valved pipe nozzle;

Figures 20 and 21 show isolator bodies interposed between a transducer and a conduit;

20

Figures 22 and 22A show an isolator body incorporated in a sensing conduit, and show signal characteristics thereof, respectively;

Figure 23 shows an isolation mounting in a conduit reflected wave system;

25

Figures 24, 24A show constructions in which transducer coupling to the fluid or housing varies with changing fluid conditions;

30

Figure 25 illustrates slant and offset mounting geometries of transducers in systems according to the present invention;

35

Figure 26 illustrates a transducer structure for use with low impedance media; and

Figure 27 illustrates a quick-connect embodiment of the invention.

Detailed Description of Invention

The invention in its various aspects and their advantages are best understood in the context of prior art flow measurement systems. Figure 1A illustrates a general flow measurement apparatus of the prior art for determining the rate of flow in a conduit 1 which may, for example, have a diameter of two and one half to fifty or more centimeters. A signal processor 5 receives signals from an assembly 10 which is fitted onto the conduit and secured in place by a clamping mechanism, illustratively straps 18. The assembly 10 includes a first wedge/transducer assembly 12 which directs an acoustic interrogation signal obliquely into the conduit 1, and a second wedge/transducer assembly 14 oriented along an oblique path in the opposite sense. Both wedge/transducer assemblies 12, 14 are adjustable to slide along a calibrated alignment frame 16, and their positions for use on a given size conduit are calculated or empirically determined to provide an interrogation path 20 of known dimension, from which transit time measurements will allow the determination of flow velocity. The oblique interrogation path 20 of these prior art strap-down systems can be tens of centimeters long, and provides good resolution of flow velocity values, as well as temporal and acoustical isolation from interfering signals propagated along the conduit wall.

This oblique interrogation geometry with reflection from the conduit interior wall finds no application to fluid flow measurement in smaller conduits. Rather, in such conduits flow rates are 5 conventionally measured by attaching the conduit to a flowcell. This provides a longer path length for the ultrasonic interrogation signals than could be obtained by oblique interrogation. Such a cell 30 is indicated in Figure 1B. In this type of arrangement, 10 the cell 30 is spliced between an inlet conduit 1a and an outlet conduit 1b via T-fittings 31, 32 so that the flow passes through a measurement passage 33 formed of a long piece of precision pipe extending between the fittings. The T-fittings 31, 32 position 15 respective transducers 34, 35 across from the ends of pipe 33, thus providing a relatively long axially-oriented interrogation path for the transducers. This construction results in abrupt right-angle flow changes at the entrance and exit of 20 the flow measurement tube 33, but this property does not seriously impair measurements, because the tube 33 and transducers are a rigid assembly which can be separately calibrated before installation. Nonetheless, the dead spaces 36, 37 in the T-fittings 25 may be a problem in many situations, and the use of a spliced-in flowcell in this manner is invasive, requiring special plumbing.

Noninvasive flow measurements are made in 30 accordance with the present invention by providing a snap-on housing that holds a transducer and positions a conduit such that the transducer is in acoustic communication with a precisely defined interrogation path.

As shown in Figure 2, in one embodiment 40 adapted to small rigid or flexible tubing, a block 41 has a conduit-receiving groove 42 into which a conduit 43 (shown in phantom) fits into a precisely defined channel, and a transducer 50 launches acoustic interrogation signals along a precisely defined flow path through the tubing. The length of this flow path is large compared to the conduit inner diameter, and for contrapropagation measurements is also large compared to the transducer diameter. Groove 42 may be of keyhole cross section to tightly receive and to retain a flexible tube engaged therein. Alternatively, the tubing may be retained by a quick-acting toggle clamp, which may have a curved surface to shape a flexible tube into a precise circular cross section when the tube is secured in the block.

In the embodiment of Figure 2, which is suitable for flexible tubing or for pre-shaped metal conduits, the groove 42 follows a smooth or streamlined curve between an entering axis "I" and an exit axis "O", forming an elbow or zig-zag 44 between the two regions. At the tip of elbow 44 a recess 46 is formed in the block to receive a transducer and position it to launch acoustic wave energy into the fluid in the tube such that the wave is launched straight along the axis "O" of the conduit.

The transducer 50 is shown removed from the recess, and is illustrated as an active transducing element 51, typically a piezoelectric crystal mounted in a stainless steel casing, and a wedge 52 which

acoustically interconnects the tube and the transducing element 51. The wedge 52 may take different forms, some of which are illustrated in Figures 2A, 2B and 2C.

5

As shown in Figure 2A, wedge 52 is a right cylinder formed of a material having an acoustic propagation speed c_w . The transducer is mounted at an angle α with respect to the tube straight axis A. The angle is selected in relation to the fluid sound speed, such that the interrogation signal undergoes refraction by angle α from the transducer axis to become parallel to the conduit axis.

15

Figure 2B shows a similar arrangement, except that the tip 53 of the wedge has a contour adapted to contact the conduit when the transducer axis T and tube axis A are aligned. In this embodiment the sound speed in the material of which the wedge is formed is selected to be approximately equal to the sound speed in the fluid within the conduit. This assures that, except for a slight lateral offset upon passing through the tube wall, the energy from transducer 50 passes in a straight direction along the tube axis.

Figure 2C shows a variation wherein the wedge 52 is formed of a right cylindrical stub which may have one acoustic speed, and a separate speed-and-contour-matching plug 54 which couples the output face of the stub to the wall of the conduit. A first face 54a of the plug engages the stub at right angles to its propagation axis to receive

acoustic energy without refraction, and a second face 54b of the plug 54 closely contacts the conduit. In this embodiment, only the plug 54 need be formed of a material with a sound speed closely matching the speed of the fluid flowing in the conduit.

Figure 3 illustrates a variation on this latter approach, in which plug 54 is replaced by a fluid-filled coupling cavity 56, which is filled with a liquid having a sound speed and temperature coefficient of sound speed about the same as the fluid to be measured in the conduit. For example, when used to monitor flow of medical fluids in an IV delivery tube, the coupling cavity may be filled with a small amount of water, for coupling into a tube of dextrose or saline.

It is understood that a complete system for contrapropagation measurement of ultrasonic signals comprises a second transducer block opposed to the first. Figure 4 shows such a pair of blocks 40, 60, wherein block 40 is identical to that of Figure 2, while block 60 shares a mirror symmetry that adapts it to fit opposite block 40 and launch signals toward it. Each illustrated block 40, 60 further has a bore 47, 67 for a receiving spacer rod to define a fixed spacing between the blocks and hence a precisely controlled interrogation path. A locking bolt 48, 68 fixes the position of the blocks along the spacer rod.

The invention also contemplates forming blocks 40, 60 as the ends of a single continuous block, with a through channel or groove securing the conduit as it passes therebetween. Such an embodiment 5 is illustrated by snap-on or clamp-on transducer housing 70 of Figure 5. In this embodiment, a channel 71 in the housing defines a precise interrogation path between transducers 72, 73. Optional cavities, attenuating plugs or other 10 acoustic discontinuities 74a, 74b, 74c, 74d in the block interrupt bulk waves that otherwise would interfere as acoustic crosstalk.

Applicant has found, however, that the 15 conduit itself may guide the ultrasonic bulk wave in a guided wave mode once launched by the transducer, so that a straight tube is not strictly necessary. Thus, in the embodiment of Figure 4, the blocks 40, 60 may be attached about a curved intermediate length 20 of tubing 61, as shown in Figure 6. For a flexible plastic tube of six millimeters diameter, it is desirable to provide a known and sufficiently long path length, of fifteen to thirty centimeters, to achieve a clearly discernible contrapropagation time 25 interval Δt . The intermediate tube segment should not be too long, however, as there is a rather large percentage of fluid energy transferred to the tube wall, resulting in high attenuation of the transmitted signal.

30

Figure 7 shows a further variant of the invention. In this embodiment, a flowcell 80 is configured as a specialized flow segment that may be

formed in line by means of suitable conduit bending apparatus, or alternatively spliced into a normal flow line. Cell 80 includes a conduit segment having inlet portion 81, flow measurement portion 82 and 5 outlet portion 83, each of which preferably extends parallel to a common axis. The inlet and outlet portions are preferably colinear, or are parallel with an offset, created by elbow 84c, 84b between each of these and the central flow portion. These 10 elbows are formed in smooth curves such that fluid flowing around the elbow follows natural streamlines and does not form pockets or regions of turbulence, in contrast to the prior art offset flowcell represented in Figure 1B. At each elbow, a 15 transducer 85 is held by a sound speed-matching potting medium, which engages the conduit and acts as a wedge 86. Figure 7A shows a section through one of the elbows 84a in greater detail. As illustrated, the transducer 85 is directed to launch its wave 20 directly along the central axis of the flow measurement path 82. Coupling medium 86 holds the transducer and tube in this orientation, and the medium is selected to have a sound speed substantially equal to that of the fluid in cell 80. 25 The dashed lines emanating from the transducer 85 indicate the beam path of the ultrasonic interrogation signals, and show the relative insensitivity of this wedge configuration to the particular pipe geometry in the elbow region. In 30 particular, when the wedge and fluid sound speeds C_1 and C_3 are matched, the tube wall introduces only a slight offset into the signal path, of a magnitude proportional to the wall thickness and the

propagation velocity in the wall. This offset is virtually negligible for thin walled metal tubes and for matched sound speed polymer tubes of any standard conduit thickness. In this context, "thin" means 5 less than one wavelength.

Rather than a coupling medium 86 formed as a cast block, a snap-on grooved block may achieve the same results. In this embodiment, shown in Figure 7B 10 and further shown in end view in Figure 7C, spring-loaded plungers 87a, 87b urge the conduit into a position to couple the transducer signals along an axial path.

15 Figure 7D shows another embodiment 88 of this transducer block, which is adapted to flow sensing in environments where the range of fluid compositions, or the range of temperature or pressure variation result in a widely varying acoustic 20 propagation speed C_3 . In this embodiment a focused transducer 85a is used that has a focus F at or near the entry of the axially-extending region of the conduit. This provides a range of incidence angles in the acoustic signal so that a portion of the 25 transducer energy will follow the axial path even when the wedge and fluid sound speeds become unmatched and vary widely with respect to each other, resulting in widely changing acoustic signal paths. In situations where the temperature varies widely (as 30 in a heat meter application with hot and cold legs) applicant further contemplates the use of an isopaustic material, such as the ATJ graphite made by Union Carbide, to form a wedge between the transducer and the conduit.

When the fluid is of very low sound speed, say below 500 m/s (e.g., air $C_3 = 343$ m/sec at room temperature), obtaining a comparably-low wedge sound speed may require using shear waves in a soft material like rubber, urethane or polyethylene. In this application applicant proposes to bend the conduit close to 90 degrees, as shown in Fig. 7D. To measure flow in air or other gases, applicant has found that plastic tubing like PVC is sufficiently attenuating at 100 kHz so that acoustic feedthrough decays quickly enough in time for the gasborne signal to arrive and be detected without excessive interference. The conduit may be coated with an absorptive jacket to enhance the rate at which feedthrough is attenuated. In some cases, the feedthrough can be recorded digitally and subtracted electronically, leaving only the fluid-propagated signal.

The invention further contemplates that the snap-on transducers described above may be adapted to rigid conduits that already have a nonlinear flow axis, such as a copper heat exchanger with tubing that has U-turns between straight runs passing back and forth in an apparatus. Figure 7E illustrates such a heat exchanger with the transducers 88 of Figure 7B or 7D attached thereto. As illustrated, a transducer block 88 conveniently fits on the only exposed segments of tubing in an otherwise occluded or covered fluid-holding assembly.

Another problem with previous clamp-on flowmeters is the difficulty of transmitting into a

low sound speed fluid, such as a cryogenic liquid, along a path having a strong axial component. These fluids have a very low sound speed, causing severe refractive effects on the launching path. At
5 cryogenic temperatures the problem is compounded by the lack of low sound speed wedge materials. This problem is addressed by one construction in accordance with another embodiment of the invention that uses a wedge made of plural dispersive elements,
10 such as rods or sheets, operated in the lowest order asymmetric (a_0) flexural mode. For these waves the phase velocity c_f is a function of the frequency-thickness or frequency-diameter product, fd , provided d is small compared to the signal
15 wavelength. With this construction by controlling f one controls the phase velocity of the incident wave. This also allows one to sweep frequency and thereby find an optimum incident velocity to launch the desired wave in the conduit.

20

Figure 7F shows such a wedge in an axial-flow sensing system 700 for use with a fluid of sound speed C_3 which is relatively low, such as liquid nitrogen, oxygen, argon or other gas. The
25 transducer 751 is coupled to the conduit 743 by a wedge 752 consisting of a plurality of thin rods, sheets or hollow tubes 752a, 752b, each of which contacts the elbow of the conduit at a different position along its curvature. The rods, sheets or
30 hollow tubes act as dispersive elements in which the lowest-order flexural wave is propagated at a frequency that provides a desired incident phase velocity to refract the wave into an axial path.

Figure 8 is a graph of flow measurements performed on flow in a three millimeter ID soft polymer medical infusion tube using the block/transducer configuration of Figure 4 and a Panametrics model V-323 broadband transducer operated at 2.25 MHz. The graph plots the predicted volumetric flow, derived from transit time measurements, against actual measured volumetric flow of water at 20°C. During the measurement protocol, a sequence of increasing flow rates (shown by crosses) and a sequence of decreasing flow rates (shown by circles) were employed. Accuracy within a few percent was obtained over flow rates from 10-700 cc/minute using digital signal processing with a clock frequency of 16 MHz. The deviation from linearity shown at rates above one-half liter/minute is believed to result from expansion of the unsupported middle portion of the tubing (41, Figure 4) between the blocks 40, 60, at higher pressures. Thus, the embodiment of Figure 5, having a closely-fitting snap-in groove to support the tube and constrain it against expansion, is expected to be more accurate in this regard. A fixed straight guide tube having a U-shaped cross-section, shown in phantom as element 42 in Figure 4 and extending between blocks 40 and 60, accomplishes this objective.

Other laboratory calibration results are plotted in Figure 8A, for flow measurements of water at 18°C, performed on a rigid wall conduit curved as in the construction of Figure 7 and having an inner diameter of .625 inches. In this embodiment, the

input and output tube segments are coaxial, and the transducer frequency is low enough (.5 MHz) so that the steel conduit wall is thin compared to the wavelength. A wedge made of 6410 urethane and having a soundspeed $C=1510$ m/sec. was used to couple the transducer output into an axial path through the flowing water. The strict linearity of the measurements of Figure 8A further confirms the accuracy of applicant's axial interrogation transducer blocks.

The above embodiments of transducer blocks which secure a conduit in a precise configuration for performing acoustic propagation measurements have been found to be effective for rigid and for flexible conduits of various inside diameters between about three and twenty-five millimeters. For larger conduits, e.g., between approximately twenty-five and one hundred millimeter diameter, applicant has found a different snap-on block structure to be useful.

Figure 9 shows one embodiment 90 of such a structure.

Block 90 is a solid block having a substantially U-shaped channel 91 formed therein for fittedly receiving a conduit or pipe 100 (shown in phantom). Each of two beveled faces 92a, 92b has a preferably threaded counterbore 93 formed therein of a size to receive a transducer 95, such as a standard stainless steel encased broadband transducer made by Panametrics, Inc. of Waltham, Massachusetts, and having an effective output/reception frequency of 500

kHz to 2 MHz. The transducer 95 includes an elastomeric or similar plug 95a which is urged tightly against the bottom of bore 93 to couple energy from the transducer into the body of block 90 5 whence it is coupled into the conduit, e.g., refracted from a direct path into an oblique, e.g., $\pi/6$ reflection path through the conduit. A two-leg path is indicated, such that the reflected acoustic wave is received by a second transducer at the same 10 angle of incidence and located a precise distance away along the conduit.

Figure 9A illustrates a detail of an alternative transducer mounting assembly 190. In 15 this embodiment a transducer has an elongated output nose 195 which is received in a through-hole 193 such that one end face 195a of the transducer assembly contacts the conduit along a line centered at the top surface of the conduit and parallel to the axis 20 thereof. With this geometry, the ultrasonic signals are launched and received in a plane passing centrally along the conduit, so that the signal passes through the region of centerline flow and so that its propagation time is relatively unaffected by 25 reflection from the curved portions of the conduit wall. As described in greater detail below, in some embodiments the through holes 193 are preferably enlarged to an oblong cross section at their ends, so that the transducer assembly may be moved back and 30 forth, and may be shifted in inclination, to launch beams into flowing fluids of differing refractive characteristics, or into conduits of differing diameters which require different transducer spacings

as well as different launching angles. A clamping screw 196 in this embodiment engages nose 195 in a small recess 195b and thereby urges the wedge end of the transducer against the conduit, and in cases 5 where the hole 193 closely fits the nose 195, it may also act as a transducer retaining screw.

In the constructions of Figures 9, 9A, the body 90 is semi-rigid and the channel 91 is shown as 10 a keyhole slot having a rounded portion consisting of slightly over π radians of a cylindrical channel "C" with a diameter equal to the diameter of an intended conduit, and a rectilinear portion "R" consisting of a slot which attains a width slightly less than the 15 conduit diameter. The conduit 100, shown in phantom, may be substantially inaccessible or blocked by surrounding structures, yet block 90 mounts by simply pressing against the conduit from one side, such that the block deforms and snaps around the conduit.

20

In lieu of the above embodiment, in which the undersize channel contour defines a resiliently biased snap-connection for gripping the conduit, the invention also contemplates transducer blocks having 25 an exact or oversize alignment channel together with separate protruding elements for aligning or biasing a conduit into a defined position for signal launching. Figure 10 shows a detail of one such embodiment 110. In this embodiment, the channel 119 30 is a simple U-shaped channel, of a size to precisely receive and align pipe 100 when the pipe is urged against the curved inner surface 111 of the channel. One or more spring-loaded pins 112 are positioned

along one face of channel 119 a distance greater than the pipe radius from surface 111, and serve to spring load the pipe into alignment. Figure 10A illustrates an end view, taken along the conduit axis. The body
5 of pin 112 screws into the block 110, and an internal spring (not shown) biases a telescoping central pin 112a upward against the conduit. One of these spring-loaded pins, say the center one in a group of three, may be replaced by a thumbscrew, which when
10 tightened a turn or two locks the assembly in proper position against the conduit.

As shown in Figure 10A, the region 113 along which energy is coupled into and out of the conduit
15 is preferably a flat surface, so that it contacts the conduit only along a narrow line lying in a propagation plane "P" passing centrally through the conduit and parallel to the flow axis. This assures that the measured transit time parameter
20 substantially corresponds to the centerline flow velocity, allowing it to be readily converted to a volumetric or mass flowrate based on the known flow profile of the fluid/conduit system and physical parameters.

25

Figure 16 shows an especially versatile snap on transducer block 1000, illustrating several other aspects of the invention, each of which may be separately implemented. In this embodiment, a block
30 1010 has a channel 1020 which receives and holds a conduit 1030 in a defined orientation. A first pair of transducers 1035, 1036 are positioned apart along the axis but on the same side of the conduit to

launch and receive acoustic waves in a first transmission mode $V(1)$, e.g., contrapropagation signals as described above in relation to Figure 9. Another one or more transducers, indicated by 5 transducer 1045 are positioned on an opposite side of the conduit to launch and receive signals in a second (reflection) mode $V(2)$. In the illustrated embodiment, transducer 1045 receives signals launched by transducer 1035 and reflected from scatterers in 10 the moving fluid. Transducer 1045 may also be paired with transducer 1036 and operated in a transmission mode. Three spaced transducers 1050, 1051, 1052 located in the block at different axial positions along the conduit may be actuated to transduce, i.e., 15 generate and detect axially-propagated flexural waves in the conduit wall. In addition, three pairs of transducers 1060, 1060a, 1061, 1061a, 1062 and 1062a, which face each other on opposite sides of the conduit, may be actuated to transduce 20 circumferentially propagated flexural waves in the conduit. The latter three pairs may also be actuated in a mode $V(3)$ to perform tag correlation measurements. In each case, the mounting block 1010 provides a precise orientation and geometry to couple 25 the transducers to the conduit wall such that the detected signals directly represent the measured flow, viscosity, fluid level, density or other fluid parameter.

30 Figures 11, 11A illustrate preferred details of construction that extend the utility of the transducer blocks to cases where it is desirable to block and/or attenuate acoustic feedthrough between

transducer regions contained within a given snap-on assembly. One construction (not shown) is to drill a series of holes perpendicular to the plane of incidence of the acoustic wave. These may be left
5 unfilled, or filled with an attenuating compound. Figure 11 shows the construction of a block 290 wherein a cavity generally located between the transducers, has installed therein an attenuating plug or block 291. Applicant has found that a three
10 dimensionally reinforced graphite composite material is highly attenuating in the megahertz frequency range, yet is quite strong, able to withstand pressures of over 20000 psi even at elevated temperature, according to the specifications provided
15 by its manufacturer, Fiber Materials, Inc. of Biddeford, Maine. This three dimensional graphite composite may be nickel plated and then soldered, epoxied or otherwise cemented into the cavity. The Figure shows a retaining plug 292 which secures the
20 packed fibrous material in the cavity.

To improve wear resistance of the snap-on assembly, a thin strip 295 of sheet metal such as stainless steel shim stock, less than about 1 mm
25 thick, and typically 0.25 to 0.5-mm thick, is also bonded to the block so as to be tangent to the conduit when the assembly is snapped onto the conduit. It thus serves as a coupling strip and wear-resistant reinforcement.

30

End view Figure 11A shows the strip 295 in relation to the mounting block body, isolation plug 291, and the central interrogation plane 299 of the

conduit. To avoid the need for a liquid or a grease couplant, the strip 295 may be selected as a resilient material such as urethane, rubber or other non-rigid material capable of transmitting megahertz waves.

Figure 12 illustrates another embodiment 390 or additional variation on the dual transducer mounting block and systems according to this aspect of the invention. In this embodiment, the channel 391 is adapted to receive and to secure in aligned contact with the acoustic launching surface, shim 295, any of plural different diameter conduits 401, 402, 403 each of which is shown in phantom. For example, one mounting block, rather than having the fixed keyhole channel of the embodiment of Figure 9, may have a rectangular channel. The coupling surface defined by shim 295 or the top surface of the channel as indicated defines a face against which a conduit is urged by a plurality of parallel positioning pegs 411, 412 or 413 (one of each being shown) positioned axially along the length of the block 390, in conjunction with one or more spring loaded conduit retaining pins 420. As illustrated, each of the pins 411-413 is positioned to center its respective conduit 401-403 under strip 295, while spring loaded retaining pin 420 is located on the other side of the central interrogation plane and urges the conduit of whatever size against the plane defined by surface shim 295 and the common plane defined by the ends of pins 411, 412 or 413 so that the conduit is in true axial alignment.

The positioning pins 411-413 are retractable, so that only the pins that are required for one particular size are moved into position and extend into channel 391 at any given time. As 5 illustrated in particular for pin 411, a mechanism 415 for releasably extending a pin into position may include a spring-loaded plunger 416 seated in a counterbore in the block 390 which bears against a circumferential groove 417 in the pin 411 when the 10 pin is pressed in. This serves to conveniently secure one pin or set of pins at a precise extension into channel 391, and to define the fixed conduit center spacing. Alternatively or in addition, one or more of the pins 411-413 may be a threaded screw 15 having a broad flat end plate, so that it can be screwed in to provide an arbitrary vernier edge adjustment to accommodate conduits of irregular shape or diameter, or tubes with a diameter differing from the discrete set of dimensions corresponding to pins 20 411-413. Figure 14D shows a section of device 510 having such a vernier adjustment 411a. Also illustrated in that Figure is a microswitch 511 which is actuated when the block is snapped onto a conduit.

25

Figures 13A-13C illustrate details of another embodiment 490 which further adapts the previously-described constructions to flow sensing in a plastic conduit 410 of defined dimensions. In this 30 embodiment, which by way of illustration will be described for application to a PVC conduit of fixed radius R , a channel 419 of inner radius R receives and aligns the conduit with a pair of transducer

assemblies 420, 430. Each transducer assembly has a crystal which is cut and aligned to generate or receive a vertically polarized shear wave. The waves traverse respective opposed plug wedges 421, 431 that contact the pipe at a relatively shallow angle, i.e., $\pi/3$ with respect to the normal plane, and are formed of a low-attenuation material such as a PVC composition which is also impedance matched to the conduit wall. For higher frequency operation, a lower attenuation material such as Ultem 1000 made by General Electric is preferred. For higher temperature operations, a polyimide such as Torlon of Amoco is preferred. As best seen in Figure 13C, each plug 421, 431 is formed with a semi-curved face 422 (respectively 432) conforming to the pipe wall.

In another embodiment 590 of a snap-on transducer block, illustrated in Figures 14A-14C a further ultrasonic propagation path is provided outside the flow conduit in a configuration for sensing temperature by means of an ultrasonic delay line 500 in thermal contact with the conduit. The delay line is a metal wire or strip fastened around or pressed against the conduit. The wire is positioned in intimate thermal contact with the conduit, and is thermally isolated from the surrounding environment. The delay line may consist of or be actuated by a magnetostrictive transducer, such as a Remendur rod energized by a coil at its end, and the measurement of Δt for signals launched in the line yields a temperature value related to the change in sound speed with temperature in the line as well as its known thermal coefficient of expansion.

In the embodiment shown in Figures 14A, 14B, the temperature sensing element is a straight metal wire carried by the block assembly 590 and pressed against the conduit. The wire is in thermal
5 equilibrium with the conduit and extends over a substantial length so that the derived temperature value indicates not just a local temperature but a more globally representative average temperature, which may extend axially or, in the sensor 501 shown
10 in Figure 14C, circumferentially. A further advantage in economy and simplicity of sensing temperature in this manner is that it uses basically the same intervalometer electronics as used for the contrapropagation flow measurement. This may be,
15 e.g., a Panametrics Model 6468T multi-channel ultrasonic intervalometer. With a transducer block having a conduit-indicating microswitch as shown in Figure 14D, the microswitch is preferably connected to activate the flow sensor or related process
20 apparatus upon attachment to a conduit.

In a number of cases the speed of sound C_3 provides the local liquid temperature T with sufficient accuracy. At a remote pipe also in the
25 flow path, not necessarily instrumented to measure flow velocity, the same or similar clamp could measure a second temperature value T' . The energy flowrate is then calculated as a term proportional to flow velocity V and temperature difference $T - T'$.
30 Note that this design avoids the need for separate temperature transmitters from such devices as thermistor sensors, RTD's, thermocouples or the like. With flow measured "redundantly" at both a

cold and a hot leg location, one can also check for leaks that are evidenced by a non-zero difference in mass flowrate at the two locations, since the mass flowrate at both locations should generally be
5 identical. In such a leak detection system the mass flowrate at each location is calculated from the volumetric flowrate Q and the density that is a function of the temperature measurement at the stations.

10

Thus, the snap-on transducer blocks of this embodiment together with an intervalometer, constitute not just flow velocity and volumetric measuring systems, but temperature measuring systems,
15 mass flowrate and energy transport rate measuring systems, and leakage detectors.

The invention further contemplates measuring mass flow rate by calculating the density from
20 measurements of the flexural or bending wave velocity in the conduit. A correction for viscosity-related effects may be introduced by determining the viscosity either as a known function of a measured temperature, or as a known function of measured
25 signal attenuation. For systems involving a two-phase fluid, the measurement of density in two different zones by flexural wave measurement provides data which, when cross-correlated, yields the flow velocity by tag cross-correlation. Multiplying
30 density by flow velocity yield a product proportional to mass flow rate. The snap-on assembly preferably contains a plurality of transducers for measuring fluid characteristics in different ways according to

how, at a given installation on a pipe, the fluid changes with time, or how conditions change as the assembly is snapped onto different pipes around a factory. The use of differing interrogation modes is
5 discussed in the applicant's book, Ultrasonic Measurements for Process Control, Academic Press, 1989, pages 359-361 and can be effected using a multichannel programmable intervalometer/flow meter unit, such as the aforesaid Panametrics model 6468T,
10 connected to various ones of the transducers.

Although the main use of the snap-on transducers discussed above is to measure the characteristics of liquids, e.g., flow, it turns out
15 that the electronics necessary to measure the flow velocity of liquids can be rather similar to that required to measure the flow velocity of gases and their sound speeds. Furthermore, the sound speed in binary gas mixtures can be related analytically or
20 empirically to the concentration of either component in the mixture. Examples include oxygen in air; the anesthetic gas Halothane in a given nitrogen/oxygen mixture, etc. In a hospital operating room environment, there is a need to measure intravenous
25 fluids like saline or blood, as well as the concentration of anesthetic mixtures, and the volumetric flowrate Q of gas into and out of the patient. While not all of these individual measurements can necessarily be made to the highest
30 accuracy subject to the constraint of snap-on transducers, several of them can now be made to sufficient accuracy by that method. Accordingly the invention further contemplates a system 600 as shown

in Figure 15. System 600 includes a multiplexed ultrasonic transit time contrapropagation flowmeter 610 such as a Panametrics Model 6468 or similar unit, wherein

5 Channel 4 measures V and c according to the principles of this invention in intravenous tubing leading to a patient;

Channel 3 measures V and c of gas exhaled by the patient;

10 Channel 1 measures V and c in a first binary gas mixture supplied from an anesthetic source; and

Channel 2 measures V and c in a second binary gas mixture (where binary here means that only one new component has been added to a known mixture
15 such as the mixture deduced from c in Channel 3).

The amplitudes of ultrasonic waves measured in channels 1-4 provide further information such as gas pressure, or the presence of either particulate or gas bubble scatterers in the intravenous
20 solution. Thus, Figure 15 represents a fluid management system in a hospital or surgical environment, wherein at least one fluid parameter is measured by the snap-on and/or noninvasive axial offset path transducer blocks.

25

In such a system, to overcome the problem of temperature variations masking or distorting the sound speed/composition relation in a gas mixture, one can devote one channel of an ultrasonic
30 intervalometer (e.g., model 6468 or similar) to temperature measurement according to principles discussed in applicant's book, Ultrasonic Measurements for Process Control, Chap. 5, Academic

Press, 1989. Applicant further contemplates symmetrical launching of torsional waves in the conduit by means of a piezoelectric couple at the end of a waveguide or at the end of a principal segment
5 of a waveguide. Applicant has found that a couple is necessary to avoid launching flexural waves; further, a smaller-diameter extension can be used to secure the main waveguide, yet be damped between the diameter step and the support point.

10

Referring again to the hospital room fluid management system, and in particular to the gas flowcells indicated for channels 1-3, it will be understood that the flowcells may need to be
15 sterilizable. An analogous situation occurs in industrial semiconductor fabrication facilities, where flowcells need to be baked out at high vacuum to assure cleanliness and prevent contamination of one gas or gas mixture by residues from a previous
20 gas that might still be adhering to the walls. In both these cases it is desirable that the transducer be of low cost.

One way to manufacture a suitable gas flow
25 transducer at low cost is to completely isolate it from the gas being measured, in the chemical sense. In other words, make the transducer as a clamp-on, or snap-on type, so the transducer never touches the gas. The principal technical difficulty is the
30 achievement of adequate acoustic isolation. This is a problem even for wetted transducers radiating into gases, and parts of the solution to the clamp-on or snap-on problem, to be described below with reference to Figure 15A, will be recognized as also applying to
35 the wetted case.

The solution to be described combines several elements: (a) Removable transducer(s); (b) Fixturing to assure reliable and repeatable repositioning of the transducer(s); (c) Slow-wave acoustic isolation structure; (d) Mechanical reinforcement of the slow-wave structure so as to substantially maintain its shape without suffering permanent deformation when the cell is evacuated as in bakeout procedures; (e) Quarter-wave impedance matcher external to the cell but attached thereto in a manner that structurally reinforces the end window(s) of the cell so that the window(s) does not permanently deform when the cell is evacuated as in bakeout procedures; (f) Attenuative material applied externally to the cell. Depending on the sound speed, impedance and attenuation of the gas to be measured, and depending on whether the cell is indeed to be evacuated and baked out, and depending on the required signal to noise ration, not all the above elements (a)-(f) need be included. In some cases, for example, elements (d)-(f) might be omitted.

Referring specifically now to Figure 15A which embodies all elements (a)-(f), let us trace the acoustic wave 19 of frequency f (for example, $f = 100$ kHz) from its generation in electroacoustic element 17 within removable transducer housing 1. The wave 19 exits from transducer housing 1 through the housing end window 1a, which may be made of plastic, ceramic or metal foil, through a relatively stiff plate 2 of thickness x_0 . Plate 2 and housing end window 1a are illustrated as flat but may be slightly curved to simplify coupling or for other reasons.

Plate 2 may be a stainless steel member of thickness $x_0 = 0.25$ mm, for example. It is coupled or bonded to a quarter-wave impedance matcher 3 of thickness $n\lambda/4$ where n is an odd integer and λ is the
5 wavelength in the matcher. The wave 19 next passes through the cell end window 4, whose thickness x_1 must be small compared to wavelength. For example, at $f = 100$ kHz, where the wavelength in SS would be about 50 mm, $x_1 \leq 0.1$ mm would be an appropriate
10 thickness. An end window this thin would deform if the cell were evacuated, unless the external atmospheric pressure were prevented from acting against it, or unless the window were reinforced and stiffened. In Figure 15A, the method of stiffening
15 consists of bonding the quarter-wave member to window, and also sealing with an O-ring 6. Adapter 15 and plate 2 and matcher 3 are attached to an acoustically-massive ring 22 that is brazed, epoxied or otherwise bonded around the end region of the
20 thin-wall tubular conduit 4a that comprises the major part of the cell 9. The attachment of this ring is accomplished by means of threaded studs 7 and nuts 8, or other conventional means. A gas entry port 20 is located near the inlet of cell 9, and another one,
25 not shown, is symmetrically located near the other end of the symmetrical cell, symmetry being indicated by centerline 21. Gas 5 enters and exits through these ports, and physical properties of the gas are measured by detection and correlation of acoustic
30 signals passing therethrough.

The speed of sound in most gases is much slower than in typical engineering metals like stainless steel, and this ordinarily leads to an acoustic short circuit problem, as discussed in the applicant's book, Ultrasonic Measurements for Process Control, Academic Press 1989, in chapters 3 and 4. But if the thickness w_1 of the wall 4a is sufficiently thin ($fw_1, \ll 1 \text{ MHz}\cdot\text{mm}$) then acoustic energy propagating as a lowest-order asymmetric (a_0) flexural wave will propagate at a phase velocity $c_f < c_{\text{gas}}$. In accordance with the illustrated aspect of the present invention, energy propagating in the a_0 mode as well as in other modes is attenuated by intentionally introducing a multiplicity of impedance mismatches along the conduit. A structure to achieve this effect is illustrated in Figure 15A and includes acoustically-massive rings 10 and 11, and an acoustically-massive spiral 12, either of which further serve as mechanical reinforcements to support the thin conduit wall during evacuation.

Further attenuation of the unwanted wall-borne energy is accomplished in this embodiment by surrounding at least part of the conduit wall 4a with dampening material 13. Material 13 may be surrounded by another thin-wall tube 14 of thickness $w_2 \ll \lambda$. Teflon, soft elastomers, urethanes, or mixtures containing Faber-Castel "Magic Rub" eraser bits have been found to be effective absorbers for waves near 100 kHz or above. Such materials may also be used as the potting medium 18 within transducer assembly 1. The spacing x_3 between rings 10 and 11, or between spiral turns, would preferably be less

than the pipe diameter D . The width x_2 is preferably on the order of a quarter wavelength of the wave to be blocked. If waves of several frequencies are to be blocked, then the inter-ring spacing dimension x_2 ought to be different for different rings; for the spiral embodiment, the pitch or the thickness of successive turns of the spiral may vary.

The matcher 3 may be made of Emerson and Cumming syntactic foam, or for higher temperatures above the rating of such a foam, of a low-density grade of graphite or a graphite composite formed of layers, each layer being thin compared to $\lambda/4$ and drilled with numerous small holes that do not align when the several layers comprising the matcher are sandwiched and bonded into a stack. The net effect is a very porous low-density low-impedance matcher. The individual layers may be electroless nickel plated and then all the layers soldered together. In these alternate constructions, the matcher is stiff and is capable of supporting pressure differentials. In this way the matcher not only impedance matches but also supports the thin window 4. The outside surface of window 4 can also be "wring" against matcher 3 using a thin layer of oil or other acoustic couplant along interface 3a. With such a coupling, the window 4 can be maintained flat, yet be removably coupled to the matcher. Plate 2, while thin, can be two to ten times thicker than the window 4, since plate 2 is on the high impedance part of the circuit, and window 4 is on the low impedance side.

The housing of the transducer assembly 1 may be metallic, e.g., aluminum, stainless steel or titanium, or may be plastic. If plastic, it is preferably shielded electrically on the inside. The housing can also contain a first impedance matching layer (not shown) of impedance Z_0 , in which case the matcher 3 must have an impedance $Z_3 < Z_0$, as may be inferred from the work of Khuri-Yakub et al. (1988), reviewed in applicant's aforementioned book, at page 125.

In the embodiment Figure 15A, the impedance-varying isolation rings or spiral are placed along the conduit, which thus contains the signal isolation structure, while the transducer housing is devoted to structural or impedance matching elements for launching the acoustic signal into a gas. Figure 17 shows a different embodiment, wherein the transducer housing itself contains the isolation structure.

In this embodiment a transducer assembly 150 includes a threaded base 152 that secures a thin-walled cylindrical housing 154 approximately twenty mils thick, having a signal-transducing crystal 156 mounted at its tip followed by suitable coupling, impedance matching and sealing elements as described in connection with Figure 15A. When the base 152 is screwed into a mounting hole, the crystal end projects into the stack or conduit. Located within the thin-walled transducer housing 154 are a plurality of massive rings 160a, 160b, 160c... which are press-fit in position and then welded. Each ring

is chamfered to facilitate insertion, and has an aperture through its center for passage of transducer wires. Each ring is approximately .25 inches thick and its edges are chamfered .06 inches. One or more 5 dimples are made on each axially-directed face of the inserts, e.g., with a prick punch, and the inserts are then pressed together so that they actually contact each other only at the dimples, and remain essentially acoustically isolated from each other 10 except via the thin walled shell. This assures that the acoustic path between the transducer crystal and the transducer's point of attachment to the stack or conduit passes through an alternating series of massive elements. While four rings are shown, the 15 invention contemplates generally three to six such elements, the number varying with the application and being generally selected based upon considerations of the desired transducer size and weight, allowable insertion loss, and the like, as discussed further 20 below.

Figure 18 shows the transducer assembly 150 of Figure 17 mounted for interrogating a flow of stack gas or other high temperature fluid. The 25 previously described sensor structure 150 is mounted within an external mounting assembly comprised of a base 160, and a surrounding sleeve or shell 162 and protective end cap 164, which together define a jacket for a flow of cooling/purge air through 30 passage 161, and via cap 164 into the sensed fluid streams. Cap 164 may include for example, one or more nickel, stainless steel or plated graphite screens 163 secured by a mounting ring 165, which in turn is affixed with cap screws 167.

In some installations it is important to be able to remove the transducer assembly without depressurizing the pipe, and without incurring the cost of leaving an "isolation valve" permanently installed at each nozzle. One way of satisfying this requirement is indicated in Fig 19. Here a nozzle extension 181 is removably attached by means of a removable ball valve 180 (shown in dashed lines to emphasize its non-permanent status) to a nozzle 183 that is welded to the pipe. The nozzle and nozzle extension are coaxially bored through to a diameter D_R and the ball valve has a passageway when open of at least D_R . A gland 185 is attached to or is part of the transducer assembly. The gland contains sealing means, illustrated as a o-ring 182 or other packing means, and is installed or removed by connecting an insertion or removal tool to the threads 184 shown at one end, or by other similar mechanical attachment. In the embodiment illustrated, the transducer assembly is installed in a slightly recessed position. Potting material 86 absorbs the ringdown within the transducer's isolation structure. The acoustic masses are coupled to the thin-wall sleeve by circumferential welds, which Applicant has found to constitute a practical joint, fabricable by electron beam welding. Alternatives include brazing or provision of epoxy between the acoustic masses and the surrounding thin-wall sleeve.

30

In the designs of Figures 17-19 discussed so far, the isolation structure consisting of alternating hi Z, lo Z impedance has been permanently

-41-

built onto the transducer assembly. To facilitate repair of the transducer, and to reduce inventory costs and possibly fabrication costs in some instances, it may be desirable to separate the piezoelectric element from the hi Z, lo Z structure. One way to accomplish such separation of elements is shown in Figure 20.

Here the transducer housing 220 contains the piezoelectric crystal, mounted against a membrane front face such as a steel membrane of thickness fifty to two hundred fifty micrometers, which Applicant has found appropriate for frequencies on the order of 100 kHz. As before, a quarter-wave impedance matcher may be installed between the piezo element and the thin window. The transducer housing 220 screws into an isolator section 230, and the isolator 230, in turn, screws into the nozzle on the pipe or stack. The isolator specifically includes a multiplicity of impedance mismatches created by alternating acoustic masses 231 and gaps 232. The gaps 232 may be on the outside or inside of the isolator, the former choice being illustrated on Figure 20. The number of interruptions in the conduit wall that are required to achieve an effective level of attenuation depends on the application, i.e., on the gas impedance and pipe material and geometry. In a very large steel pipe, e.g., a stack pipe one meter in diameter filled with ordinary air, the transit time across the air diameter path at 20°C is about three milliseconds. In this time interval the short circuit or crosstalk decays quite a bit at 100 kHz, and so only a few sections of hi Z, lo Z conduit mismatch are

-42-

required. But for a small steel pipe, of about 50 mm diameter, the transit time for air at room temperatures is only about one hundred fifty microseconds. In this case, about six sections are
5 required, preferably arrayed three on each side of the path. These illustrative numerical examples apply for transducers radiating through very thin diaphragms, a construction in which the diaphragms also contribute to the isolation, If thicker windows
10 are used, more isolation steps are required in the hi Z, lo Z structure.

In cases where many sections of hi Z, lo Z alternation appear necessary but where space is
15 restricted in the nozzle's axial direction, a reentrant isolator structure may be employed, as illustrated in Figure 21. In this embodiment the transducer 220 is mounted at the end of one leg 240 of the isolator structure, and the far end of the other
20 leg 250 attaches to the conduit. Each leg has a structure of alternating impedance mismatches resulting from radially-oriented circumferential slots. As shown, the irregular slotted surfaces of the two legs are essentially enclosed by the legs
25 themselves, rendering the structure largely resistant to clogging accumulations.

Unlike structures of packing washers or the like which have been used to isolate transducers,
30 this structure can be used in a steam environment without waterlogging, deteriorating or changing its properties, and is composed entirely of perfectly elastic, rather than visco-elastic elements.

Viewed as a function of distance along the housing or conduit from the transducer crystal, the acoustic impedance of the isolation structures described herein will be seen to have the profile of a square wave, with a peak-to-valley ratio corresponding to the thickness of the original stock and the depth of the isolating slots 232 (Figure 20). Preferably this impedance alternation ratio is over 3:1, and more preferably, greater than 6:1.

10

This aspect of the invention may also be implemented using conventional conduits and fittings in a variety of ways. For example, a structure wherein the alternating masses are placed about the conduit between two transducers, rather than between a transducer crystal and the conduit, may be constructed as shown in Figure 22. In this system 260, a pair of opposed transducers 261, 262 launch and receive signals through a fluid path constrained by a conduit formed of alternating segments of one and a half-inch pipe couplings 263 and six inch lengths of pipe 264, the couplings having a much greater wall thickness and acoustic impedance than the pipe lengths. Figure 22A shows an oscillogram of a received signal propagated through air in the isolator conduit embodiment of Figure 22, indicating the very low level of crosstalk (region A) and the well defined transmitted signal (region B).

30

To quantify the nature of impedance mismatch created by the alternating masses and their effect on particular signals, one must deal with the wave impedance, and that means knowing exactly what the

wave of interest is, which is to be isolated or blocked by successive mismatches. For many of the frequencies and dimensions of concern here, not just one wave but several are involved, including 5 different modes, e.g., flexural, symmetric and asymmetric. Although we may not know the exact formula for impedance for each wave mode of interest, one can make the assumption that the magnitude of the wave impedance is proportional to the mass per unit 10 area in a plane perpendicular to the axis of the isolator section. This means that one can represent the impedance function like a square wave drawn on a graph of mass per unit area (y-axis) vs axial dimension (x-axis). In the "square wave" the peaks 15 and valleys do not need to have equal durations; applicant has found that very small gaps between masses suffice.

Unlike typical impedance mismatches in the 20 prior art consisting of alternating materials such as asbestos-like gaskets sandwiched between steel washers, the present case involves lo Z, hi Z steps created by differing amounts of essentially the same material, typically metal. This new alternation is 25 amenable to sandwiching masses between concentric thin wall sleeves and thus the lo Z parts are sealable against water or ice and thereby made weatherproof. In contrast, prior-art gasket isolators are subject to being compromised by 30 moisture from weather or other sensed environment, such as steam encountered in steam flowmeters.

Intuitively one might expect that the greater the number or magnitude of Z steps in the square wave, the better the isolator becomes. This turns out to not always be true. In order to optimize the isolator with respect to specific requirements such as minimum weight, minimum length, etc., applicant offers an analysis based on a simple form of the energy transmission equation, $T = 4r/(r + 1)(r + 1)$ where r is the ratio of impedances of the small and large mass sections. A few numerical examples will help explain the optimization found by the applicant, as set forth in the following table, Table I.

15

| TABLE I | | | |
|---------|------|-----------------------------|------------------|
| r | T | INSERTION LOSS, 10 log T,db | IL/r, dB/Section |
| 20 | 1 | 0 | 0 |
| | 2 | .889 | .51 |
| | 3 | .750 | 1.25 |
| | 4 | .640 | 1.94 |
| | 5 | .556 | 2.55 |
| 25 | 5.81 | .501 | 3.00 |
| | 6 | .490 | 3.10 |
| | 7 | .438 | 3.59 |
| | 10 | .331 | 4.81 |
| 30 | 14 | .249 | 6.04 |
| | 20 | .181 | 7.41 |
| | 30 | .125 | 9.04 |
| | 38 | .100 | 10.00 |
| 35 | 50 | .077 | 11.14 |

Table I shows several interesting points.
 40 First, as the impedance peak/valley ratio, r, increases, the insertion loss (IL) increases, but not

linearly. This is seen from the fact that values of $r = 6, 14$ and 38 yield IL's of approximately $3, 6$ and 10 dB, respectively. Second, to get a "useful" insertion loss of at least 3 dB, one requires a value of $r > 5.81$. Third, to achieve a particular level of insertion loss it is not immediately apparent whether it is "better" to use a large r or two sections each having half that value of r . For example, $r = 4$ yields more insertion loss than two sections with $r = 2$. Likewise $r = 6$ yields more than two sections of $r = 3$. But $r = 10$ does not yield more than two sections of $r = 5$. This means that if a particular level of IL is required, and if the solution must not exceed a particular weight limit, one cannot simply choose a very large r . It may be necessary to use n sections of an intermediate r value, such that $(n \times IL_0)/(n \times r_0) = IL_0/r_0$ is maximum or near-maximum. The last column of Table I shows that IL/r appears maximized when r is about 6 . If other conditions allow it, this choice of r is preferred, because it allows a given IL to be achieved at minimum mass, for $IL > 3$ dB.

It is to be understood that the number of sections may be comprised all in one transducer, shared between two transducers, or shared among transducers and separate "isolator" sections formed in or on a mounting, or about the conduit.

The invention also contemplates the incorporation of isolated transducers directly into equipment other than ducts. For example, the transducers can be installed in valve bodies,

preferably upstream from the valve mechanism. The elimination of crosstalk makes it possible for isolated transducers of the present invention to achieve highly accurate measurements in diverse such structures without requiring specially designed flow cells and custom mounting.

Figure 23 illustrates such a system wherein left and right flow segments 271, 272 lead through a valve body 273, and each segment is provided with a pair of isolated transducers 271a, 271b or 272a, 272b for detecting flow in the segment. In this embodiment, bidirectional flow is contemplated, and instrumentation preferably responds to the direction of flow by selecting the pair of transducers which are upstream of the valve body to conduct flow measurements. In cases where minimum length is absolutely necessary, it may be possible to straddle the valve mechanism with a pair of transducers 273a, 273b. Readings in this case may be possible in only some of the setting positions of the valve mechanism, depending on the extent to which the mechanism interferes with the acoustic beam path between this transducer pair.

25

Returning now to the constructions of Figures 15A and 17 involving a thin diaphragm or window, certain preferred constructions are proposed for reasons of safety to deal with either an occasional or accidental overpressure event in the sensed fluid.

In one variation of the transducer mounting, a support is provided that is slightly spaced, by about one mil, from the diaphragm end window. Figure 24 shows such an embodiment 275, wherein a transducer 5 crystal 276 attaches, via a $\lambda/4$ matching block 277, to a diaphragm 278 which normally is spaced one mil from a supporting body 274 at gap 279. Thus, at low pressure in what we may take as normal operating conditions, the support means does not come into play 10 and so does not introduce acoustic crosstalk. In these conditions the gas pressure is so low as to yield only weak ultrasonic signals, the detection of which would be jeopardized by strong crosstalk. But when pressure becomes high, the support 274 limits 15 the motion of the diaphragm to safe excursions by bearing against the diaphragm. In so doing, crosstalk is increased, but at the same time the signal strength increases due to better match between transducer and gas impedances. Hence the signal to 20 noise ratio can still be high enough to allow useful measurements. The effect of residual crosstalk can be reduced by recording it as a function of pressure and/or temperature, and then subtracting the recorded values from the resultant (signal + noise) detected 25 signal.

Figure 24A shows an adaptation of the construction of Figure 23 to an isolated transducer housing and mount 280. Transducer crystal 282 is 30 coupled to a diaphragm 281 by a couplant, and a pedestal 283 almost spans the cavity between the other side of the crystal 282 and a shoulder of the thin-walled cylindrical isolation section 285 which

is, for example, similar to that of Figure 17. As the external gas pressure in the sensing chamber to the right of the crystal rises, pressure builds up at shoulder "A", allowing the crosstalk to increase under the high pressure conditions in which adequate signal strength is achieved. The transducer is thus enabled to operate faithfully over a broad range of pressure conditions.

10 One embodiment of the foregoing construction is especially applicable to a low impedance gas, for example, in aerospace situations where gaseous hydrogen or other gaseous cryogens are involved. In these cases, one of the collateral problem is
15 coupling the piezoelectric element to the window. Bonding sometimes works, but because of differential expansion coefficients it is advantageous to have some degree of flexibility in the couplant. There seem to be so far no really "flexible" couplants
20 known or available to function at temperatures of liquid nitrogen (-196 °C) and below. Applicant has found, however, that the anti-gall compound sold under the trademark Never-Seez [manufactured by Never-Seez Compound Corp., Broadview, IL] can be
25 applied between two surfaces at room temperature, squeezed thin and then it couples ultrasound well at room temperature and also at -196°C. Hence this compound can be introduced as a couplant between the crystal and the end window in the isolated transducer
30 designs shown herein, to operate when the application spans all the way down to cryogenic levels. The Never-Seez material was developed for use at high temperatures, over 1000 °C, so this one couplant will

operate at both extremes of temperature. A conservative transducer rating would be +/- 200 or +/- 250°C. Applicant has identified a second anti-gall compound, sold under the trade name Permatex, Part No. 133K, made by Loctite of Cleveland, OH, which is also normally intended for high temperatures, and this too is useful as a cryogenic couplant that can be applied at room temperature. Other suitable cryo couplants may be found among "anti-gall" lubricating compounds.

Another factor addressed by subsidiary aspects of the invention relates more to high temperature gas flows. When transducers made according to this invention are installed in pipes at temperature extremes, the angle that the transducer axis is to make with the pipe depends in part on whether the objective is to have the sound beam's transit time be influenced by flow, or not be so influenced. To be immune to flow, e.g., to measure density or the like, installation would typically be perpendicular to the pipe axis. But if one wants to measure flow by the contrapropagation method (as described for example in applicant's book, Ultrasonic Measurements for Process Control, Academic Press 1989, chap. 4), the usual method is to install transducers at 45 degrees to the flow axis. However, at temperature extremes, if the transducer is recessed in a nozzle, this creates a still region or refraction wedge where the nozzle port enters the freestream, that can significantly divert the propagation path.

-51-

To minimize refraction, applicant recognizes that the angle of incidence should be as near zero as practical. On the other hand, too small an angle means that the small upstream - downstream path component results in a time difference that is too small to be measured accurately. Ideally one would like to use normal incidence, thereby avoiding the refracting wedge at temperature extremes, and yet achieve a useful propagation path component $L > \text{zero}$.

10 Applicant has found that at 100 kHz, where commercially available ultrasonic flowmeters such as the Panametrics model GP68 can resolve Δt to 10 ns, a useful minimum Δt is 1 μs , where $\Delta t = 2LV/c^2$. (This sensitivity corresponds to

15 flow resolution of 1%.) In large pipes of diameter $D > 300$ mm at high flow velocities, it often turns out that an L of a few centimeters suffices, say $L = 3$ cm = 30 mm. Thus L/D may be on the order of $30 \text{ mm}/300 \text{ mm} = 0.1$. Now if the half-angle of the

20 ultrasonic beam in radians measured at the -3 dB points exceeds L/D , normal incidence can be used, and the transducers can simply be installed offset by the axial distance L . This simplification is important with respect to safe hot tapping and nozzle

25 attachment, since these installation operations are greatly simplified at normal incidence.

In cases where both low and high flows can occur, all at high temperature, for example, the

30 invention further contemplates providing multiple sets of ports. As shown in Fig. 25, a stack system 186 has different fixed ports for measuring different flow rates. For high velocity flows, the ports 287a,

287b, 288a, 288b can be at normal incidence, while the ports 289a, 289b for low velocity can be oblique because at low velocity the refracting wedge is not so distinct since the free stream temperature tends to penetrate into the port.

When using the flow-cooled transducer of Figure 18 at low flows, the Bernouli effect may not be sufficient to draw cooling air into the free stream and thereby provide self-cooling and self-purging. In other cases air may be a hazardous or disturbing addition to the composition of the measured gas in the stack. In such cases a positive flow of an acceptable, perhaps inert, gas, e.g., pressurized nitrogen, may be introduced as a preferred purge gas.

In still other cases, as where an electric arc is to be extinguished, sulfur hexafluoride may be the preferred purge gas. In one example of such a case, a minimum mass flow of SF_6 must be valved into lower-pressure lines, and it is necessary (in one application in which 362 kV and 800 kV double pressure circuit breakers are employed) to ultrasonically verify within 60 ms that the required flow has occurred, or else a safety circuit triggers other more disruptive protective devices. In this application the flow is both transient and turbulent, and it is difficult to measure the flow velocity accurately in so short a time. Applicant proposes to measure such flow indirectly, by instead ultrasonically measuring the temperature change in the gas based on sound speed (as described in

applicant's aforesaid book, chap. 5). Here the temperature is measured over one or more paths to obtain a meaningful average temperature, which, integrated over time, provides a measure of the
5 change in gas mass remaining in the supply reservoir. The transducers for such applications where the conduit is already all welded together in an existing plant, are preferably of the clamp-on type. But when such gas conduit systems are designed
10 with ultrasonic interrogation in mind, one can provide for transducers or conduits with the isolated design of the present invention. This is expected to yield higher accuracy than obtainable with clamp-on transducers.

15

Figure 26 illustrates another embodiment for an isolation-mounted transducer 200. In this embodiment, an alternating-impedance isolation body 210 is interposed between the transducer crystal 215
20 and the solid body path of the conduit walls, and the crystal radiates at grazing incidence to excite a thin-walled extended source 220 that radiates or receives the ultrasonic interrogation wave through a surrounding medium. The thin-walled source 220 is
25 thin compared to the wavelength, e.g. preferably under $\lambda/10$ and no more than $\lambda/2$ thick, and is preferably stainless steel containing a wedge 218 made of a low sound-speed material such as CMG or ATJ graphite, or chalcogenide glasses or plastics. The
30 low sound speed contributes to a large refracted angle according to Snell's law. On the other hand if a small refracted angle is sought, then a high sound speed material is preferred, e.g., alumina, beryllia or perhaps beryllium.

35

In many of the above-described applications, it is desirable to perform several occasional sets of measurements on a conduit, without any continuing need to monitor fluid parameters, or, as in Figure 5 10, one desires to place the transducers at different positions depending on present flow levels. For these applications applicant proposes a conduit-to-transducer mounting as shown in Figure 27. In this embodiment a isolation-mounted transducer assembly 50 10 is provided with a quick-disconnect stem fitting 50a, and a corresponding quick-disconnect body 50b is fitted to the conduit or reservoir wall. Suitable interconnecting body and stem parts are, for example, are Swagelok fittings SS-QF-12-B-12-PM and 15 SS-QF-12-S-12-PF. For lower pressure applications, the transducer assembly need not be provided with such secure pressure fittings, and the corresponding mounting may comprise simply a precision bored nozzle and closely fitted cylindrical transducer body which 20 is simply placed in the nozzle bore and positioned or retained by a spring-loaded ball detent. The quick-connect may have an automatic shut-off or alternatively a plug may be used when the transducer is out.

25

The invention may be embodied in other specific forms without departing from the spirit or essential characteristics thereof. The present embodiments are therefore to be considered in all 30 respects as illustrative and not restrictive, the scope of the invention being indicated by the appended claims rather than by the foregoing description, and all changes and variations which

come within the meaning and range of equivalents of the claims are therefore intended to be embraced therein.

5 What is claimed is:

Claims

1. A flow measurement system for the noninvasive determination of the rate of flow of a fluid flowing in a small diameter tube, such system comprising
a first end block having a first signal transducer mounted therein and including means for securing the tube in a streamlined curve and for positioning the first transducer so that it couples acoustic signals along a flow path extending axially along a portion of said tube, and
a second end block having a second signal transducer mounted therein and including means for securing the tube in a streamlined curve and for positioning the second transducer so that it couples acoustic signals axially along said flow path,
the first and second end blocks being in upstream and downstream locations relative to each other for launching and receiving counterpropagating signals along said flow path.
2. The system of claim 1, wherein said first and second end blocks are ends of a single housing which secures said tube such that a central straight portion defines an acoustic flow measurement path.
3. The system of claim 1, wherein said flow path is curved and the acoustic signals in the fluid are axially guided by the tube.
4. The system of claim 1, further comprising means for defining a fixed spatial separation between said first and second end blocks.

5. The system of claim 1, wherein said flow path is long compared to the diameter of the tube.
6. The system of claim 1, wherein the acoustic signals are flexural waves which are guided by a tube outer wall.
7. The system of claim 1, wherein the tube is a flexible tube and a said end block includes a contoured groove into which the tube releasably fits and is positioned by the groove to constitute the flow path along which the acoustic signals are axially coupled.
8. The system of claim 7, further comprising a wedge which couples a said transducer to the tube, said wedge being characterized by a sound speed selected, in relation to the sound speed in the fluid in the tube, to refract an acoustic wave in said wedge such that the wave follows an axial path in said tube.
9. The system of claim 7, wherein the tube is an elastically extensible tube having dimensions which expand with increasing fluid pressure, and the contoured groove constrains the tube to have a substantially constant dimension thereby enhancing accuracy of flow rate measurements.
10. An ultrasonic transducer assembly comprising a body,
an elongated channel formed in said body, said channel having an axis and side walls adapted for resiliently and releasably receiving a conduit and holding the conduit aligned along the axis, and

a pair of transducer elements mounted in said body for launching and receiving counterpropagating signals through a fluid flowing in the conduit when the conduit is held in said channel, 5 said transducers being symmetrically positioned such that the signals reflect off an inner wall of the conduit along a signal path therebetween.

11. An ultrasonic transducer assembly according 10 to claim 10, wherein said channel has an arcuate contour conforming to a conduit outer wall, and resilient means biases the conduit against said arcuate contour.

15 12. An ultrasonic transducer assembly according to claim 11, wherein said arcuate contour comprises a curved wall extending more than π radians of arc along a radius substantially equal to the radius of the conduit, whereby the conduit snaps into the 20 channel and is resiliently held thereby in contact with the body.

13. An ultrasonic transducer assembly according to claim 10, further comprising 25 positioning means extending inwardly of said channel to define contact points which position any of plural different size conduits in axial alignment with said channel, and biasing means for urging any of said plural 30 different conduits into acoustic contact with corresponding positioning means such that the conduit extends axially along the channel in contact with said transducer elements.

14. An ultrasonic transducer assembly according to claim 13, further comprising means for positioning the transducer elements at any of a plurality of discrete positions, respective pairs of positions 5 being located to propagate signals along symmetric reflection paths between the transducers through conduits of different sizes positioned in said channel by said positioning means.
- 10 15. An ultrasonic transducer assembly according to claim 13, wherein the positioning means comprises a vernier adjustment for continuously varying a contact point to precisely center an irregular conduit with respect to a transducer.
- 15 16. An ultrasonic transducer assembly according to claim 10, wherein the transducer elements include crystals adapted to launch ultrasonic waves of two different modes.
- 20 17. An ultrasonic transducer assembly according to claim 10, wherein the transducer elements launch vertically polarized shear waves into the conduit via contoured wedges which conform to an exterior wall of 25 the conduit.
18. An ultrasonic transducer assembly according to claim 10, wherein the ultrasonic transducer elements are adapted to launch and receive wave 30 energy along a vertical plane passing centrally along the axis of the conduit.

19. An ultrasonic transducer assembly according to claim 10, comprising transducers positioned to effect tag cross-correlation measurements of fluid flowing in the conduit.

5

20. An ultrasonic transducer assembly according to claim 10, comprising transducers positioned to effect measurements of acoustic signals received in a reflection mode from fluid flowing in the conduit.

10

21. An ultrasonic transducer assembly comprising a body,

an elongated channel formed in said body, said channel having an axis and side walls adapted for receiving a conduit and holding the conduit aligned along the axis,

a transducer mounted in said body and positioned to determine a precision propagation path with respect to fluid in said conduit such that ultrasonic signals launched by and received by said transducer couple along a defined path adapted to sense a characteristic of fluid in said conduit.

22. An ultrasonic transducer assembly according to claim 21, wherein said transducer is positioned to launch and receive bulk wave energy along an axial flow path through said fluid.

23. An ultrasonic transducer assembly according to claim 21, wherein said transducer is positioned to launch and receive via the conduit wall guided wave energy, propagation of which varies with the density of fluid contained in the conduit.

24. An ultrasonic transducer assembly according to claim 21, wherein said transducer is positioned to launch and receive via the conduit wall wave energy which reflects off the fluid in said conduit.

5

25. An ultrasonic transducer assembly according to claim 21, wherein said body has mounted therein plural transducers positioned for performing tag correlation measurements of fluid flowing axially
10 along the conduit.

26. An ultrasonic transducer assembly according to claim 21, wherein said body has at least three transducers mounted therein that are not all on the
15 same side of the channel.

27. An ultrasonic transducer assembly according to claim 21, wherein ones of said transducers operate in a transmission mode and a reflection mode.

20

28. An ultrasonic transducer assembly according to claim 26, wherein ones of said transducers operate in a transmission mode and a reflection mode.

25 29. An ultrasonic transducer assembly according to claim 21, further comprising electrical switching means mounted in said body and extending into said channel, such that the switch is activated when a conduit is held in said channel.

30

30. A system for the measurement of a characteristic of a fluid by generation of ultrasonic signals with a transducer and propagation of the signals in the fluid, ultrasonic signals generated by the transducer being propagated partly as a measurement signal through the fluid, and partly as an interfering signal through material or structures supporting or containing the transducer and the fluid to be measured, and characterized in having a plurality of alternating masses interposed in the path of the interfering signal between a transmitting transducer and a receiving transducer.

31. The system of claim 30, wherein the alternating masses constitute regions of high impedance alternating with regions of low impedance, and are formed of substantially the same material.

32. The system of claim 30, wherein the alternating masses include thick rings and thin cylinders placed in alternation with each other.

33. The system of claim 32, wherein the thin cylinders are portions of a cylindrical shell supporting an ultrasonic source away from a conduit or reservoir wall.

34. The system of claim 33, wherein the rings are contiguous and have irregular contracting surfaces that do not allow acoustic energy to propagate therebetween, so that acoustic energy propagates through successive rings only via an adjacent thin cylinder.

35. The system of claim 31, further comprising quick-connect means for releasably coupling the transducer to a fluid housing without rotation of the transducer.

5

36. The system of claim 31, further comprising a thin diaphragm coupling the transducer source to the fluid, and a support structure housing the transducer source to normally define a gap
10 between said support structure and at least one of the transducer source or the diaphragm thereby decreasing crosstalk, the support structure and flexibility of the diaphragm cooperating as pressure of the medium increases, to firmly support the
15 diaphragm thus increasing crosstalk under pressure conditions in which transmitted signal strength is also increased whereby extension of the useful operating range of the transducer is achieved.

20 37. The system of claim 31, wherein the alternating masses include a plurality of massive rings spaced along a conduit enclosing a fluid path along which the measurement signal is propagated.

25 38. The system of claim 31, wherein the alternating masses include a plurality of massive rings spaced along a support member between a transducer and a conduit mounting opening extending in a direction opposite to a path followed by the
30 measurement signal.

39. The system of claim 31, wherein the alternating masses include at least three massive rings.

35

40. The system of claim 39, wherein the alternating masses include at least five massive rings.

5 41. The system of claim 33, further comprising a sleeve surrounding the cylindrical shell and forming a coolant envelope thereabout for channeling purge fluid about the transducer.

10 42. The system of claim 30, comprising a transmitting and a receiving transducer mounted at normal incidence in positions axially offset from each other along a conduit.

15 43. The system of claim 31, wherein the alternating impedances have a ratio of at least 3:1.

20 44. An isolation member for interposition between an ultrasonic transducer and a mounting opening in a fluid container, such isolation member comprising a cylindrical shell adapted to receive the ultrasonic transducer at one end and to mount in the opening at its other end, and a plurality of masses attached to the cylinder along its length.

25 45. An isolation member according to claim 44, wherein the masses are sealed between inner and outer cylindrical walls.

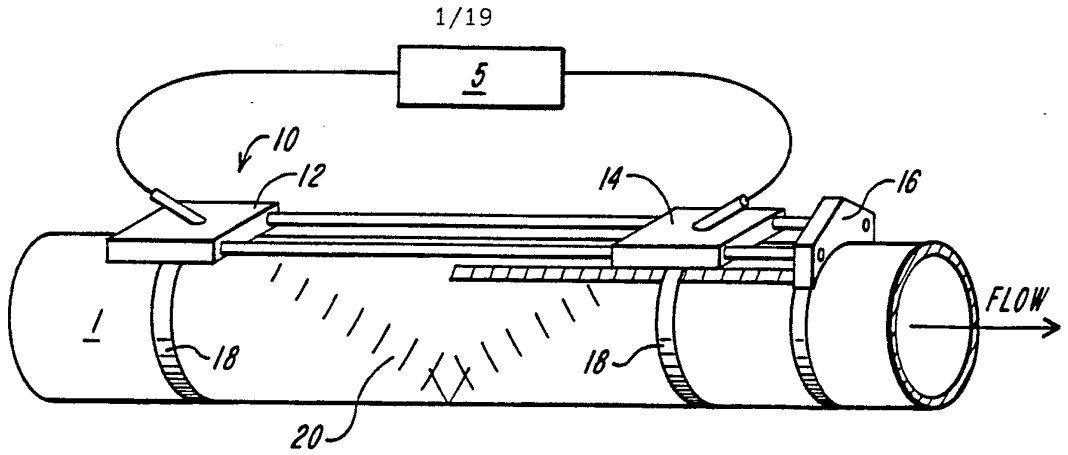

FIG. 1A
(PRIOR ART)

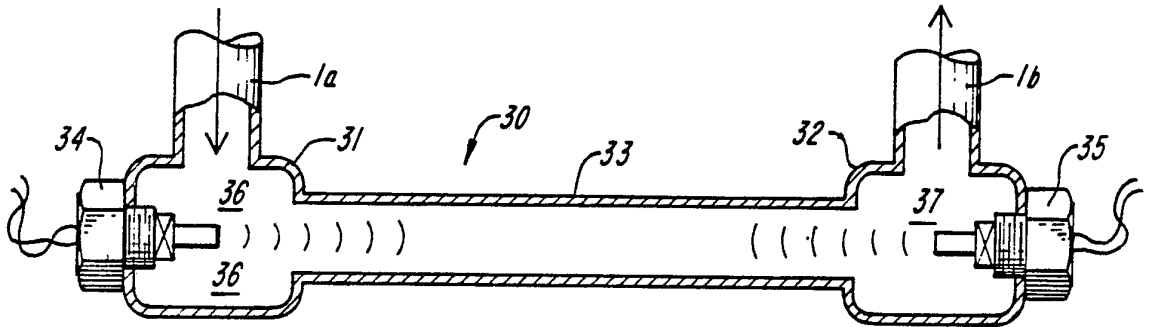

FIG. 1B
(PRIOR ART)

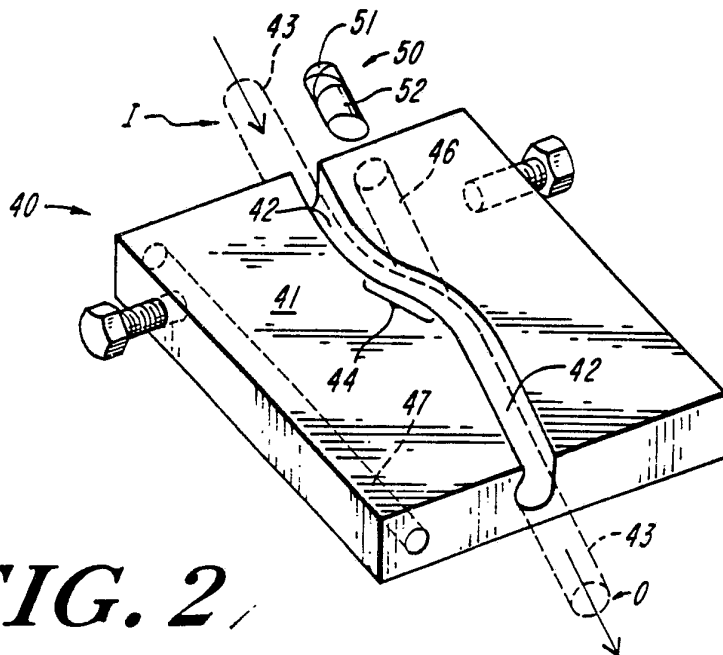

FIG. 2

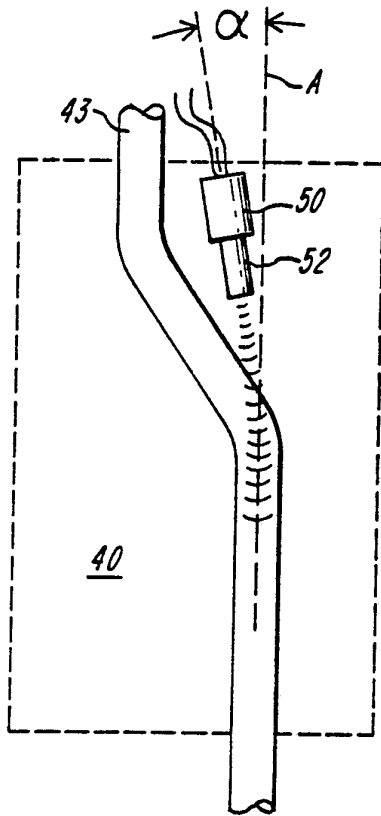

FIG. 2A

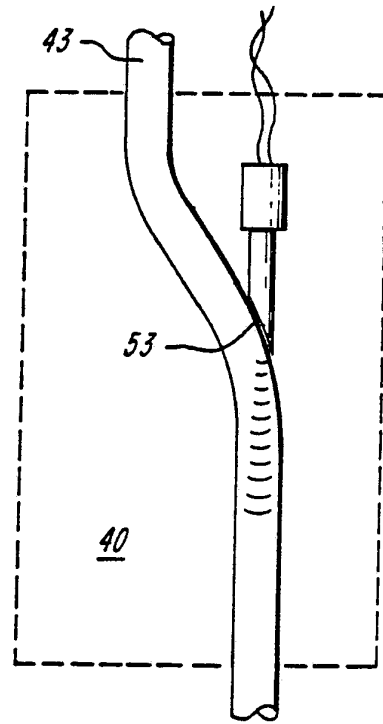

FIG. 2B

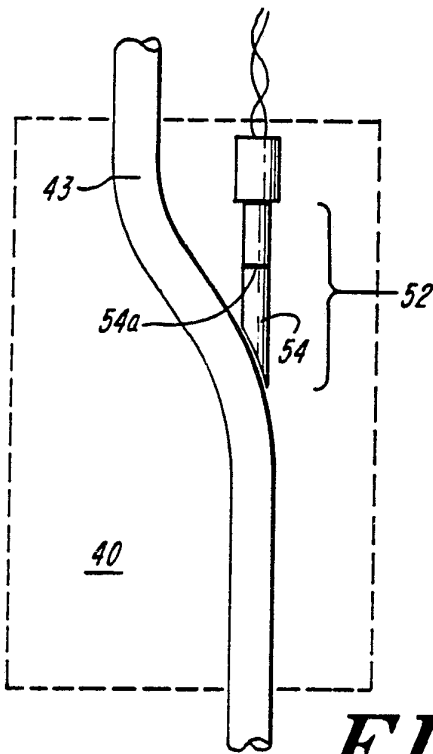

FIG. 2C

3/19

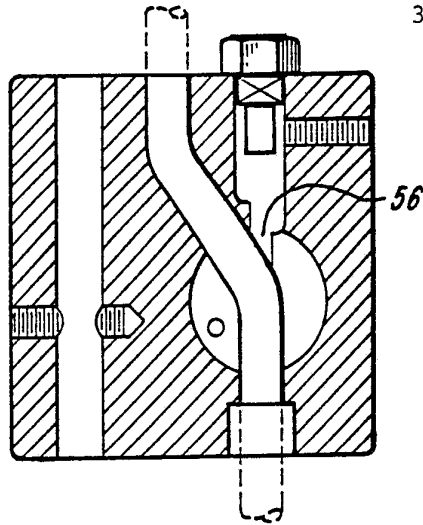

FIG. 3

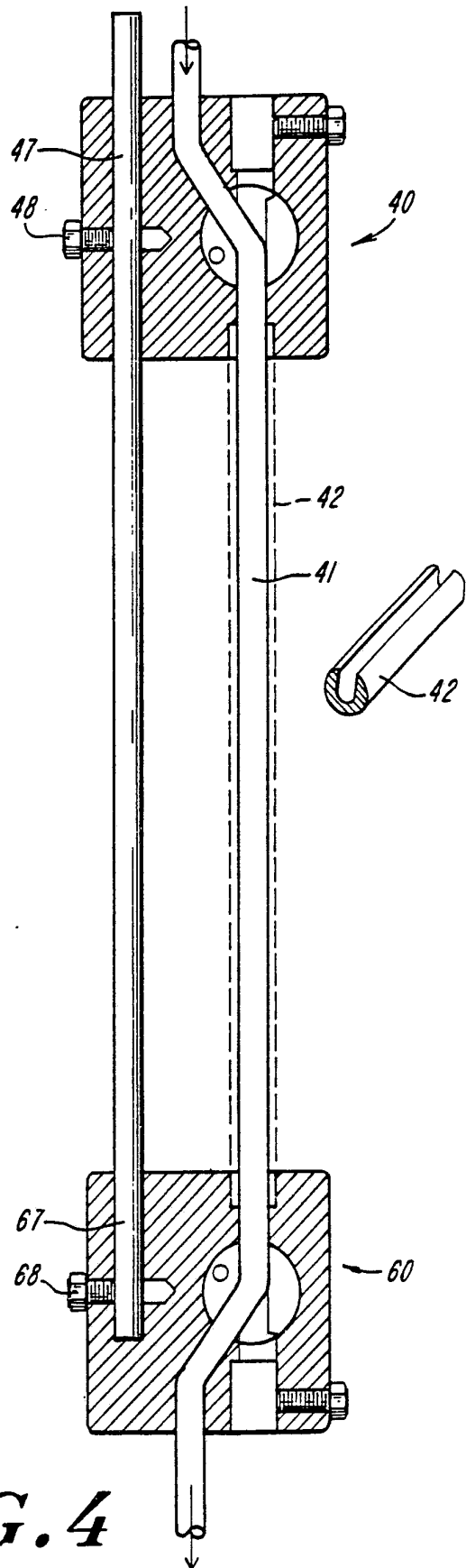

FIG. 4

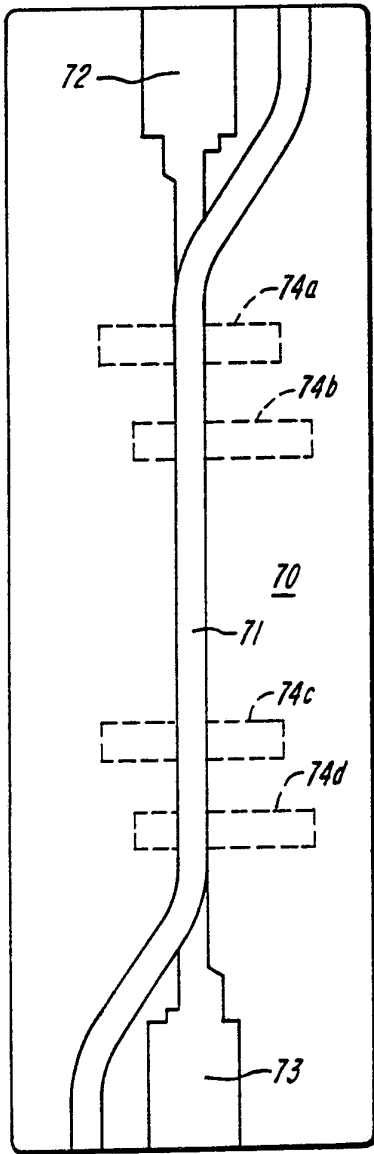

FIG. 5

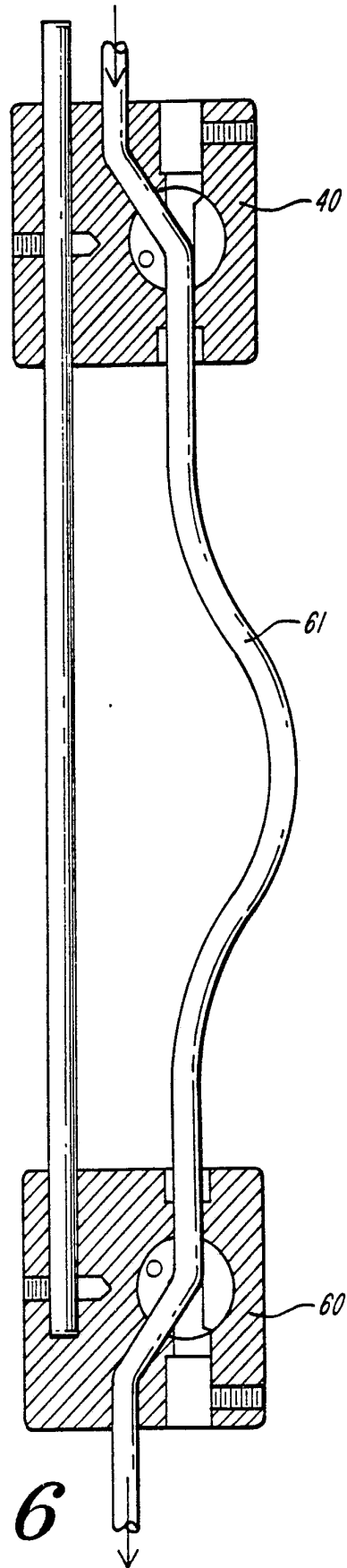

FIG. 6

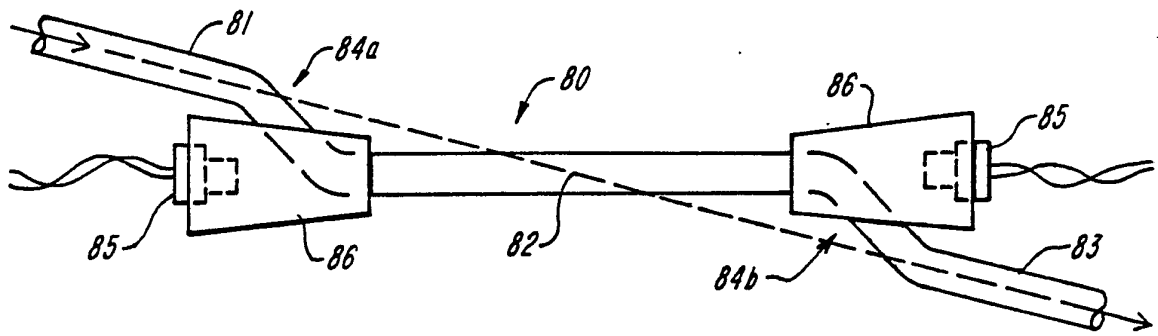

FIG. 7

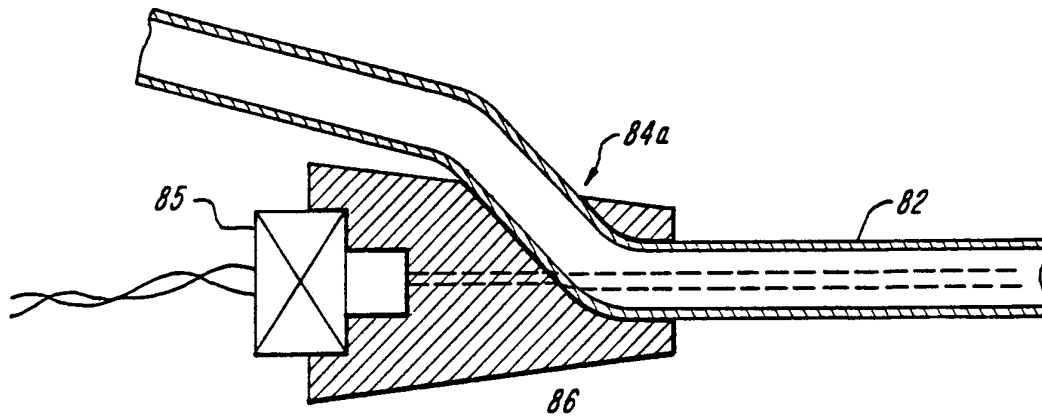

FIG. 7A

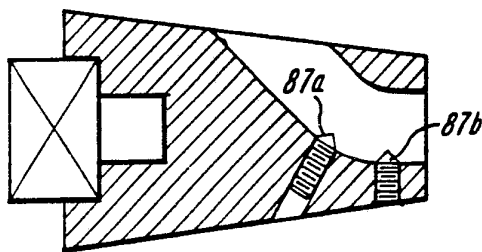
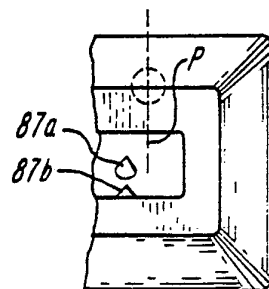

FIG. 7B

FIG. 7C



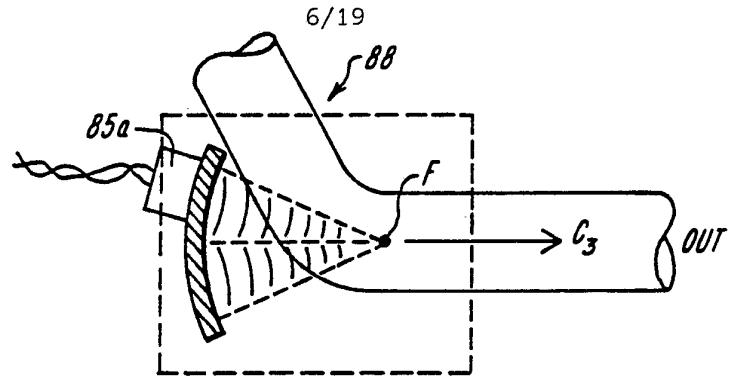

FIG. 7D

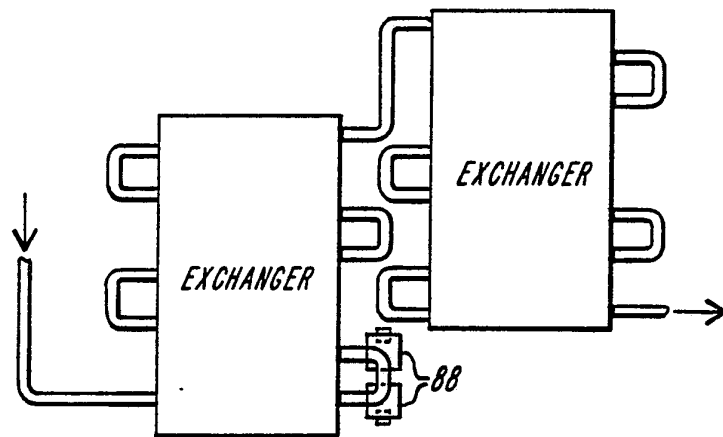

FIG. 7E

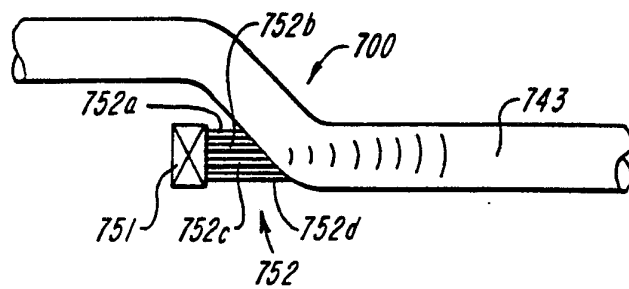

FIG. 7F

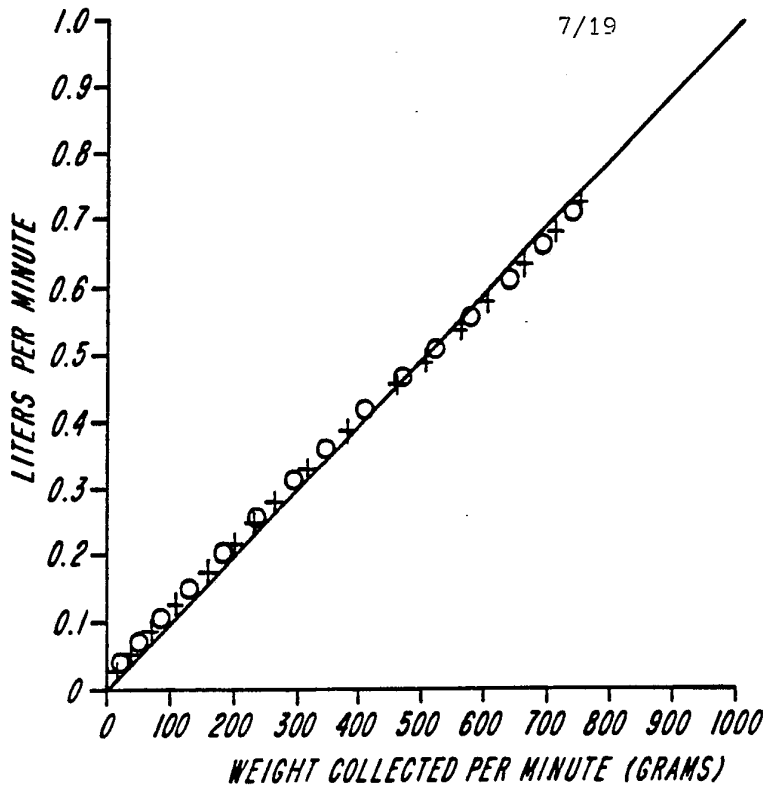

FIG. 8

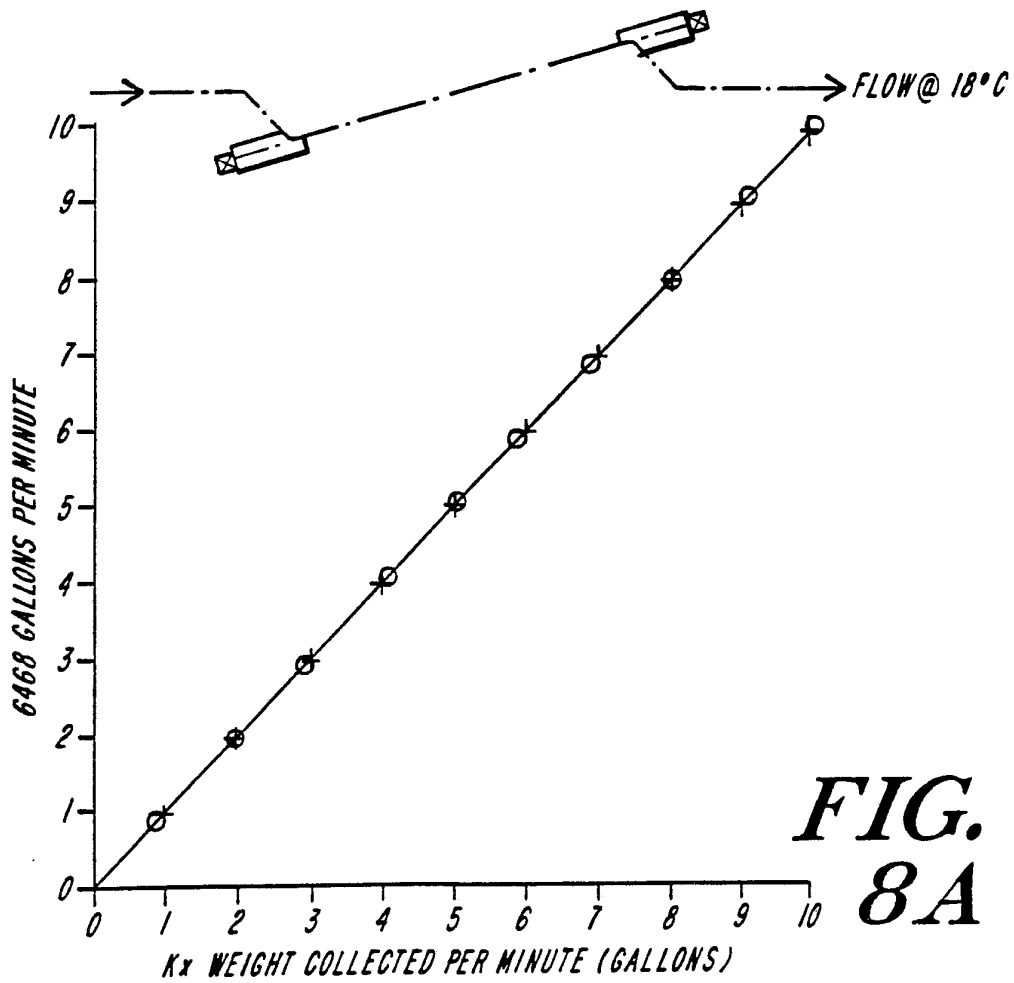

FIG. 8A

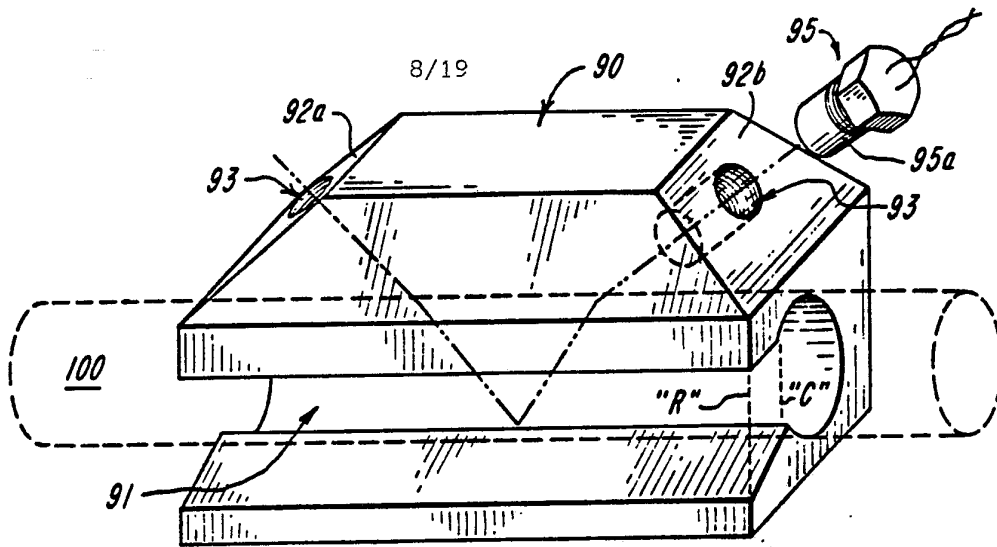

FIG. 9

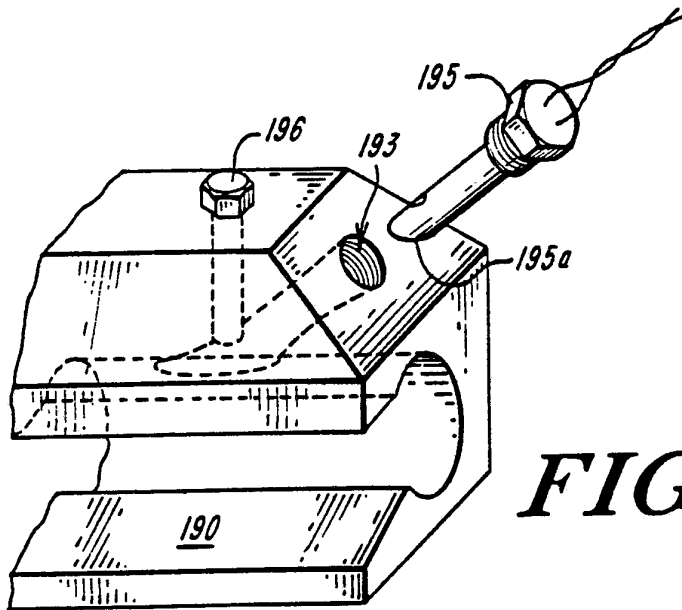

FIG. 9A

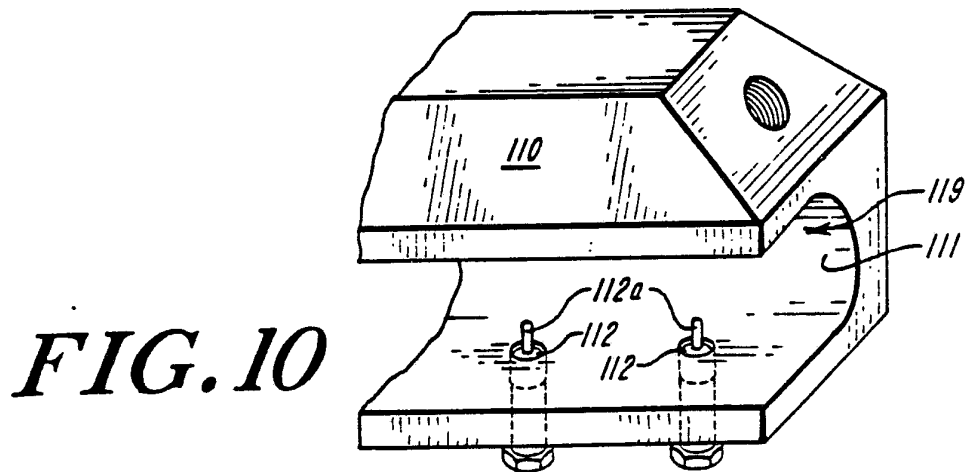

FIG. 10

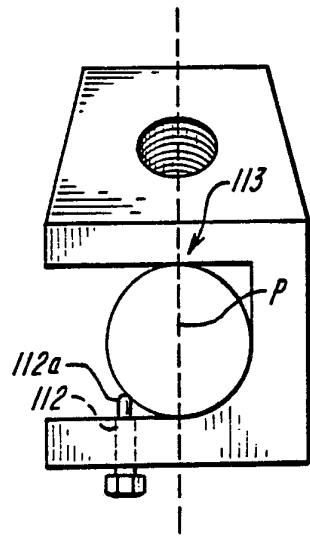

FIG. 10A

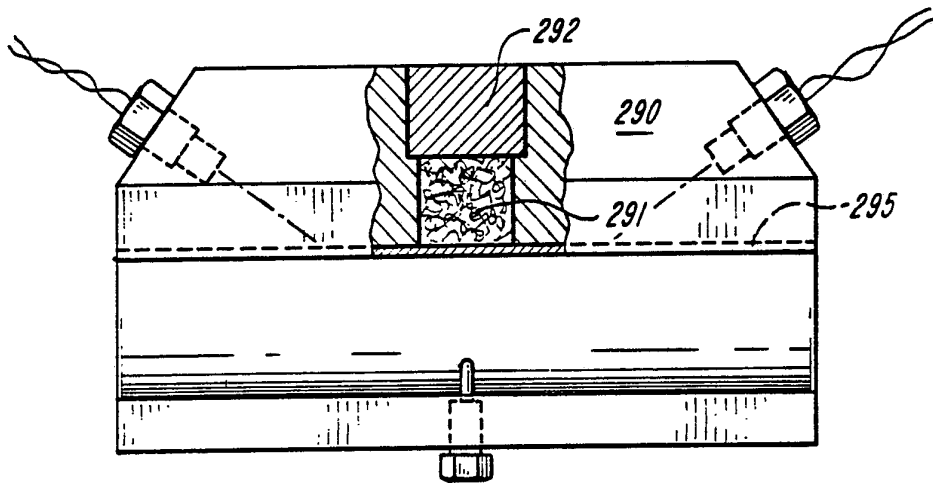

FIG. 11

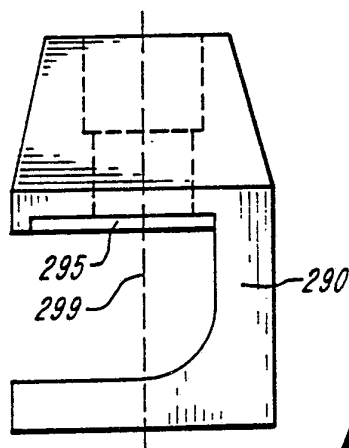

FIG. 11A

10/19

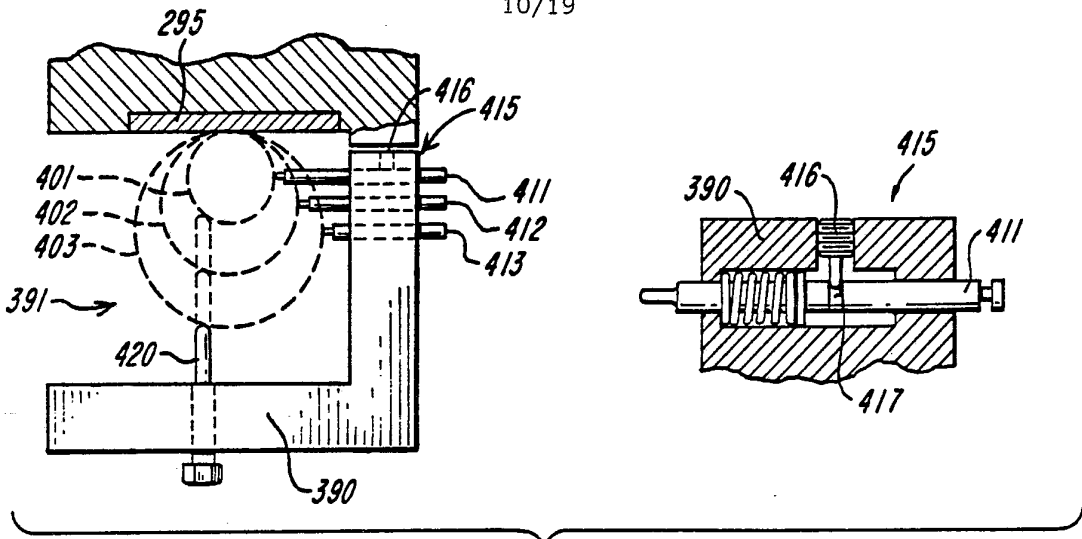

FIG. 12

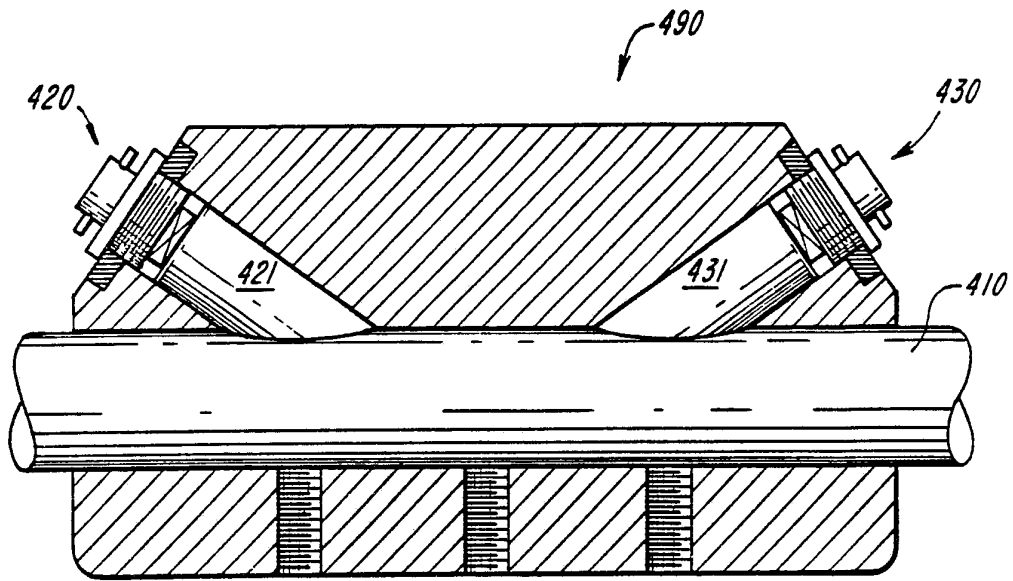

FIG. 13A

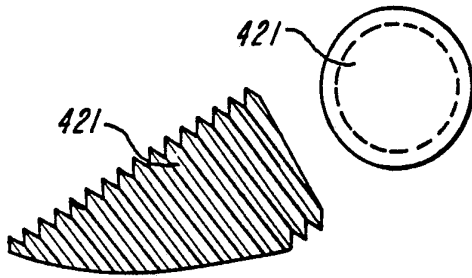

FIG. 13 B

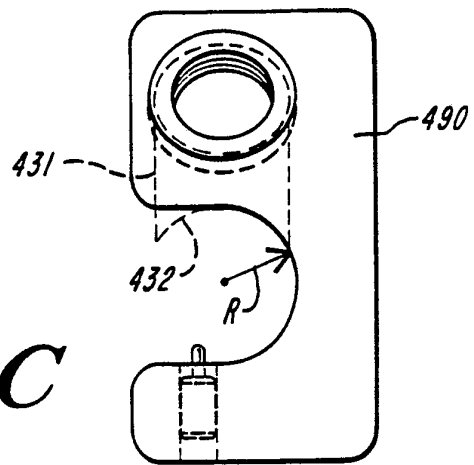

FIG. 13 C

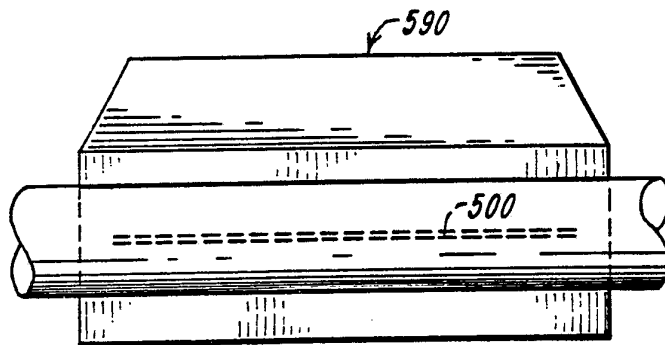

FIG. 14 A

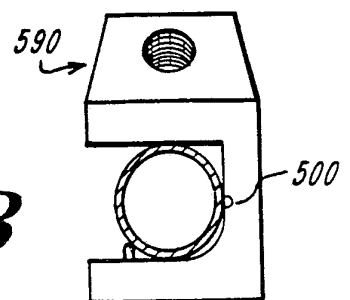

FIG. 14 B

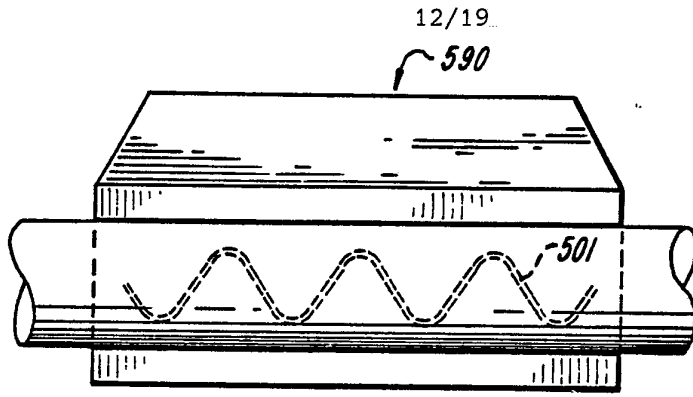

FIG. 14C

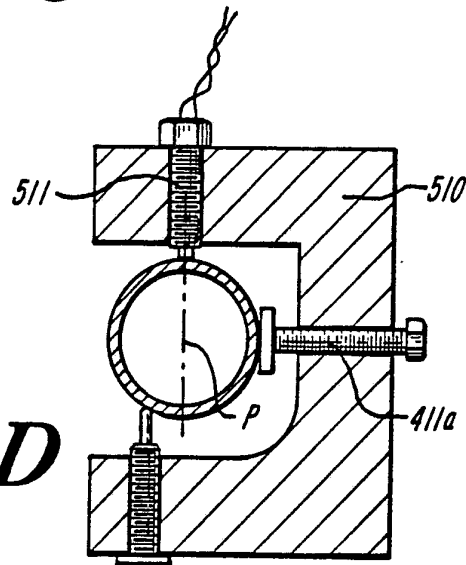

FIG. 14D

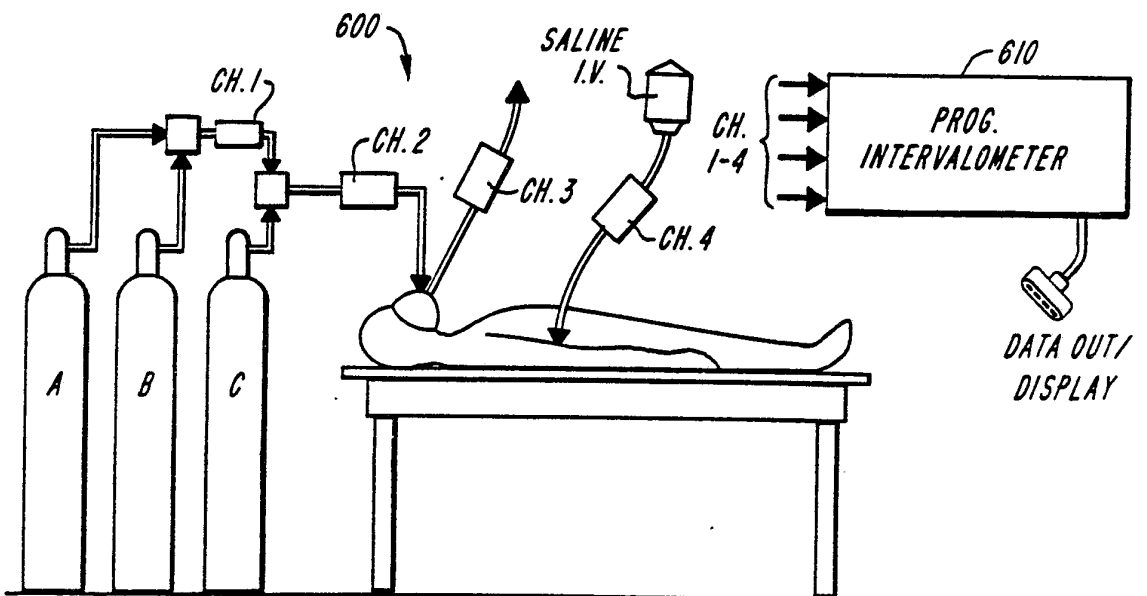

FIG. 15

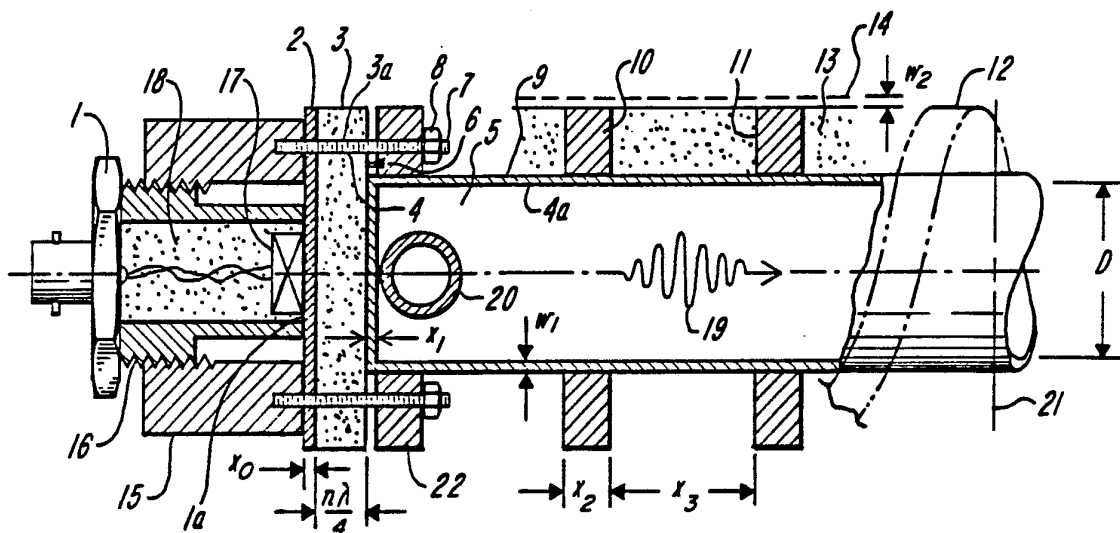

FIG. 15 A

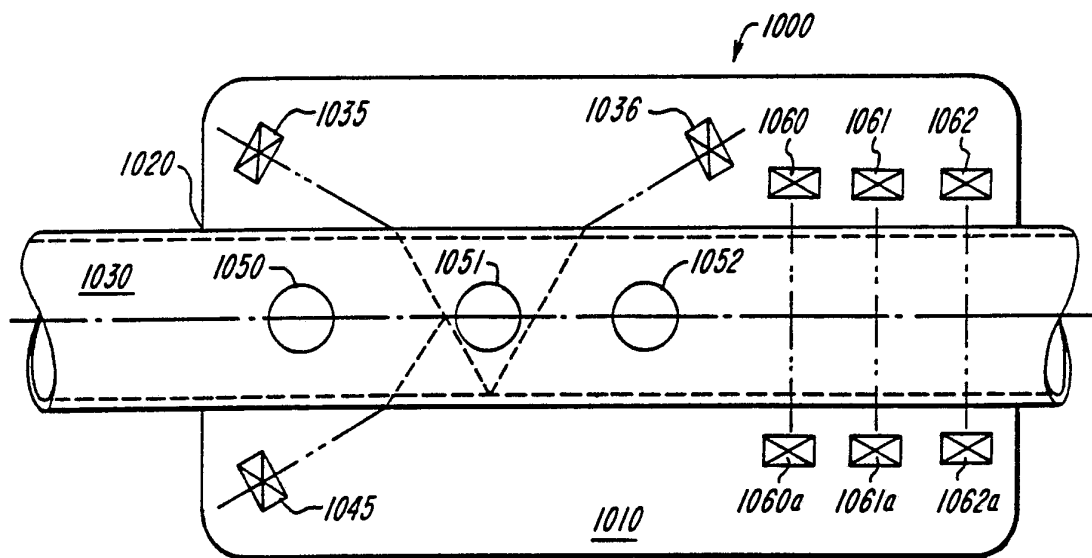

FIG. 16

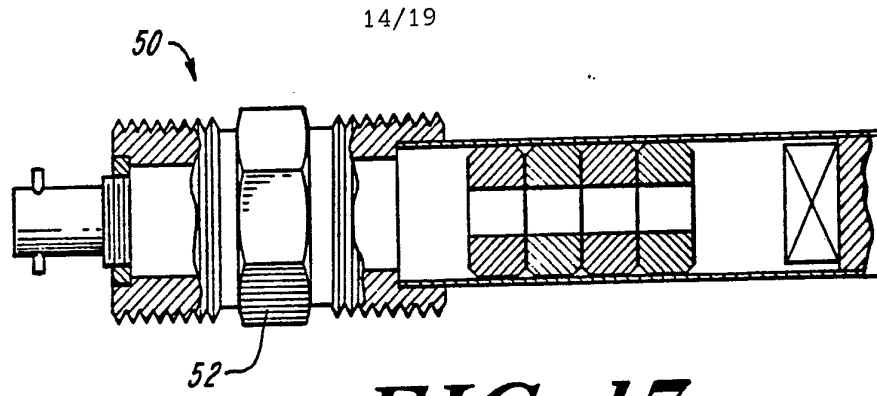

FIG. 17

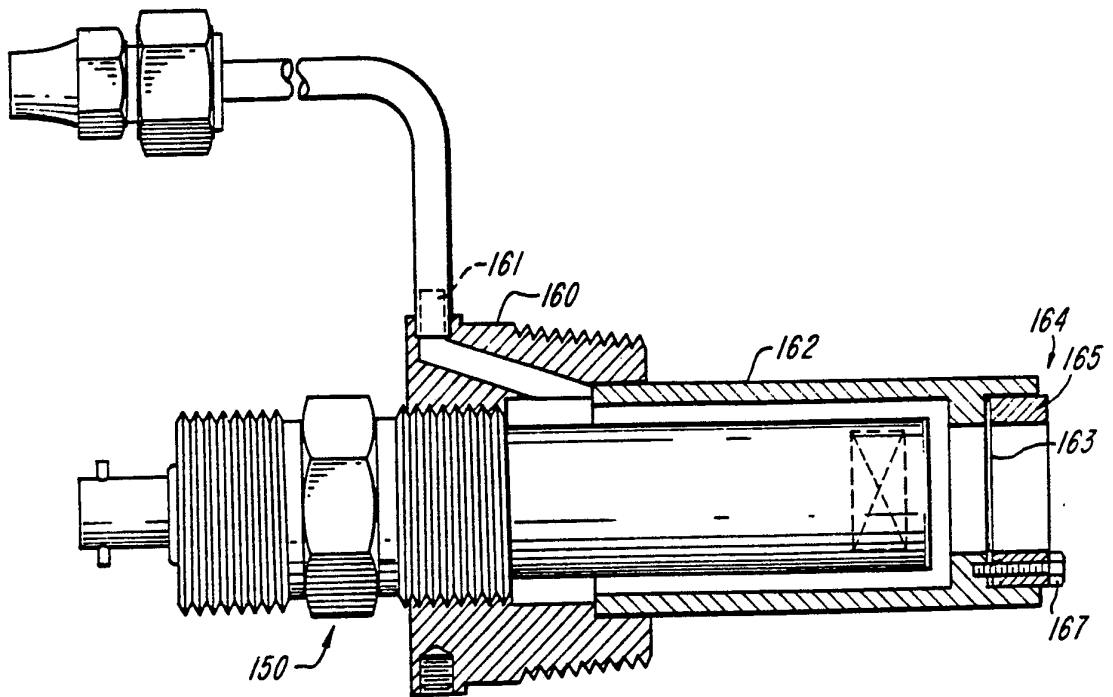

FIG. 18

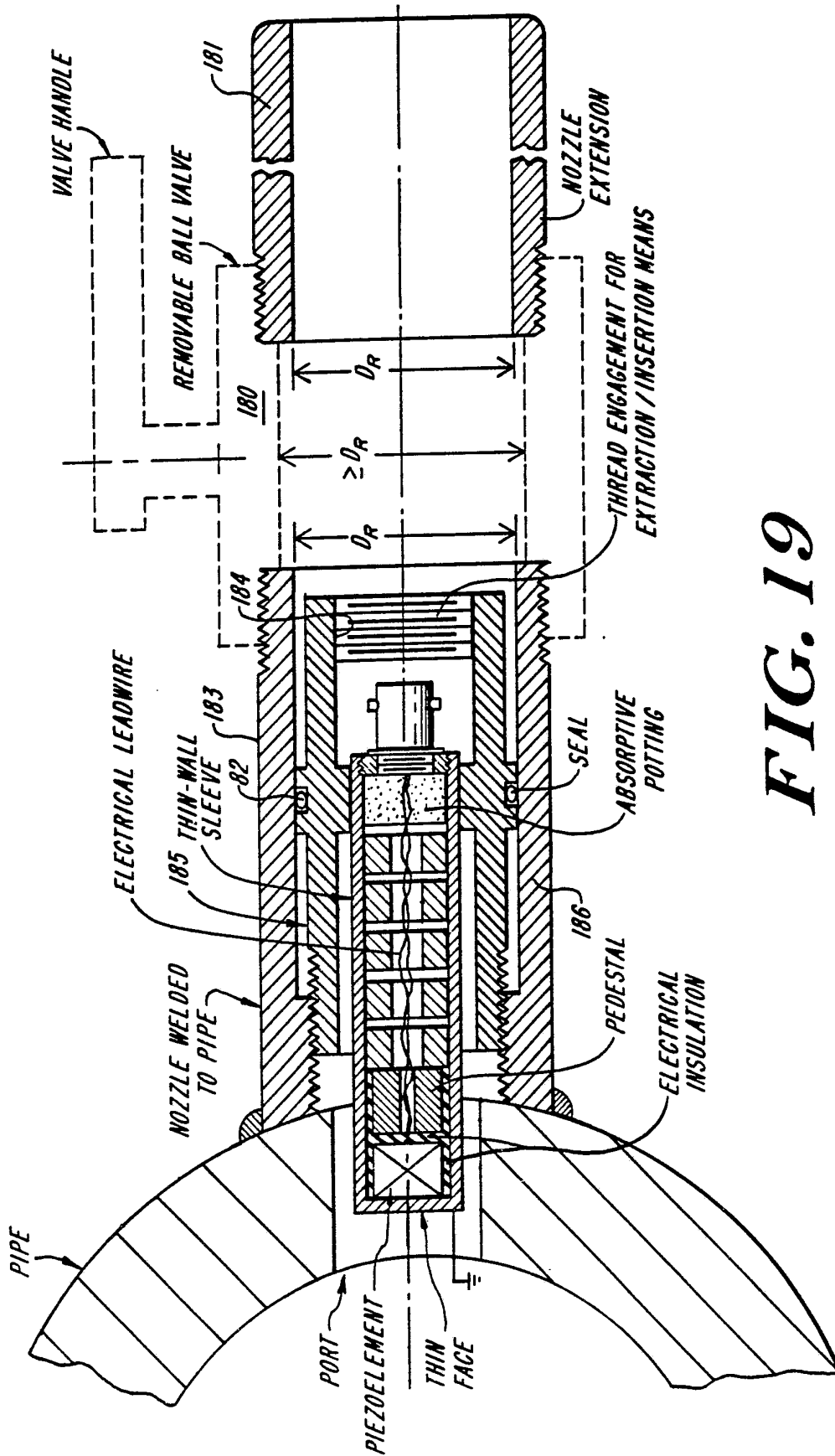

FIG. 19

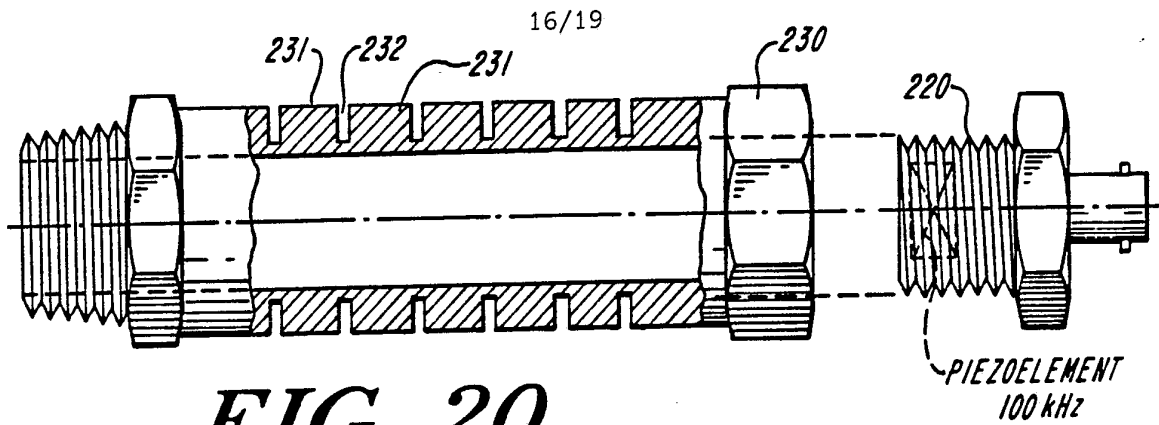

FIG. 20

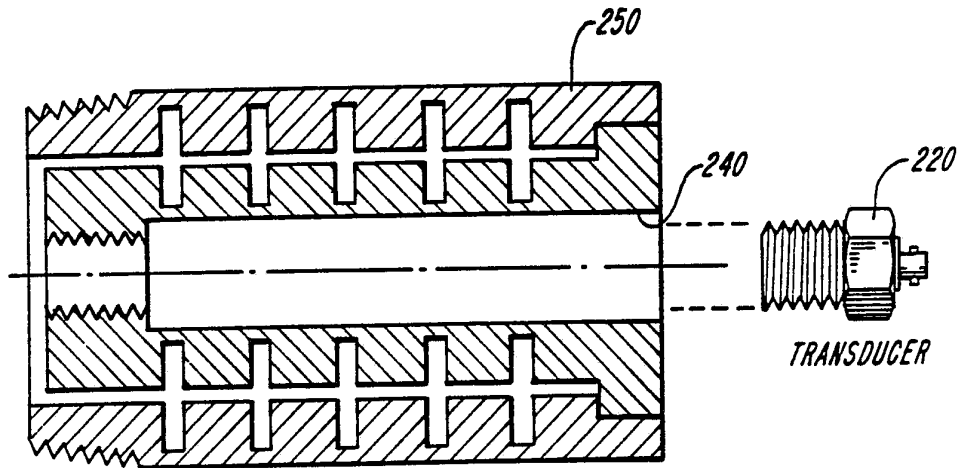

FIG. 21

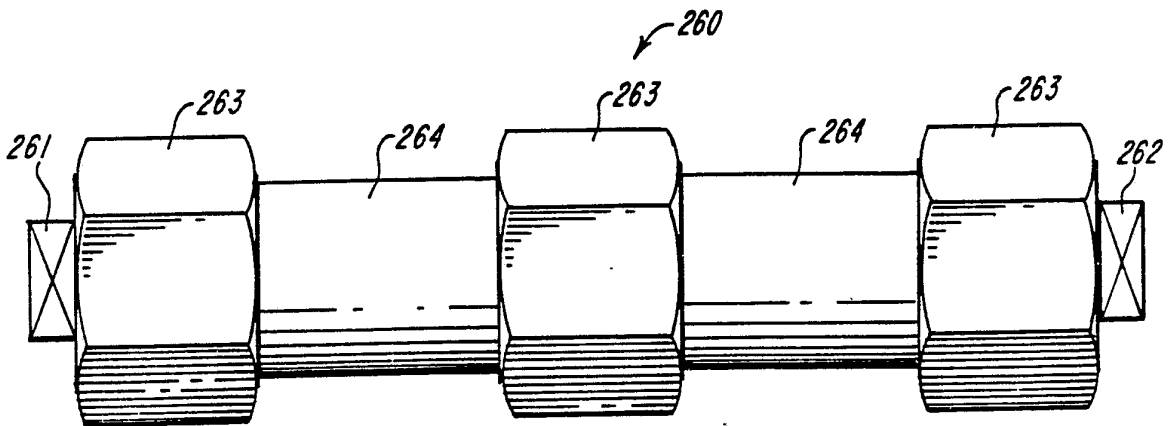

FIG. 22

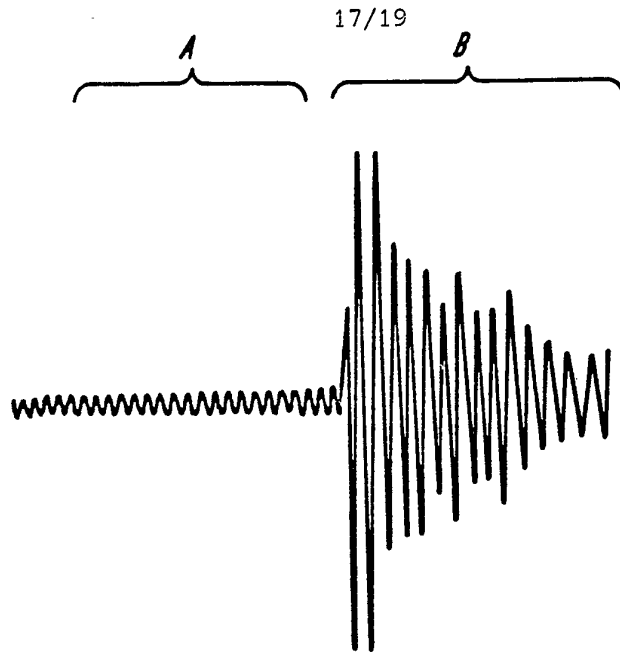

FIG. 22A

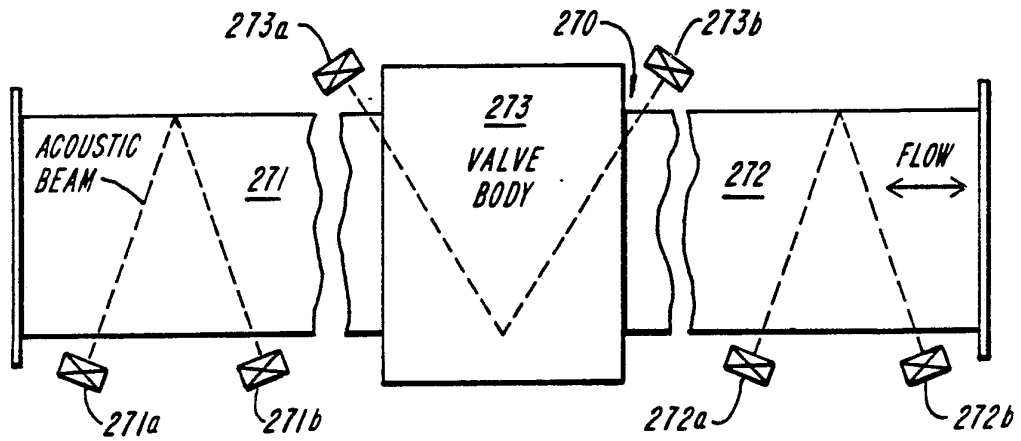

FIG. 23

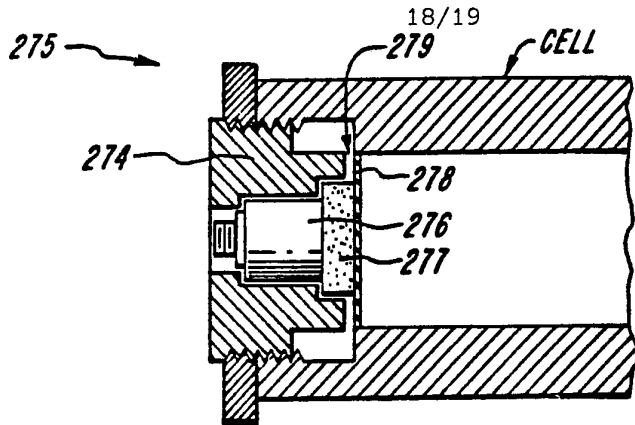

FIG. 24

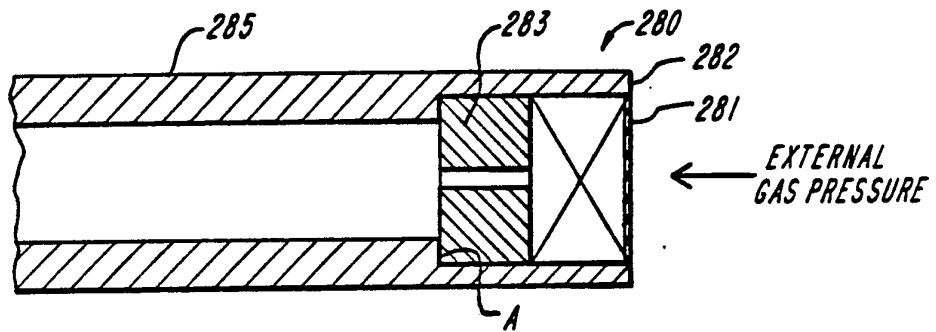

FIG. 24A

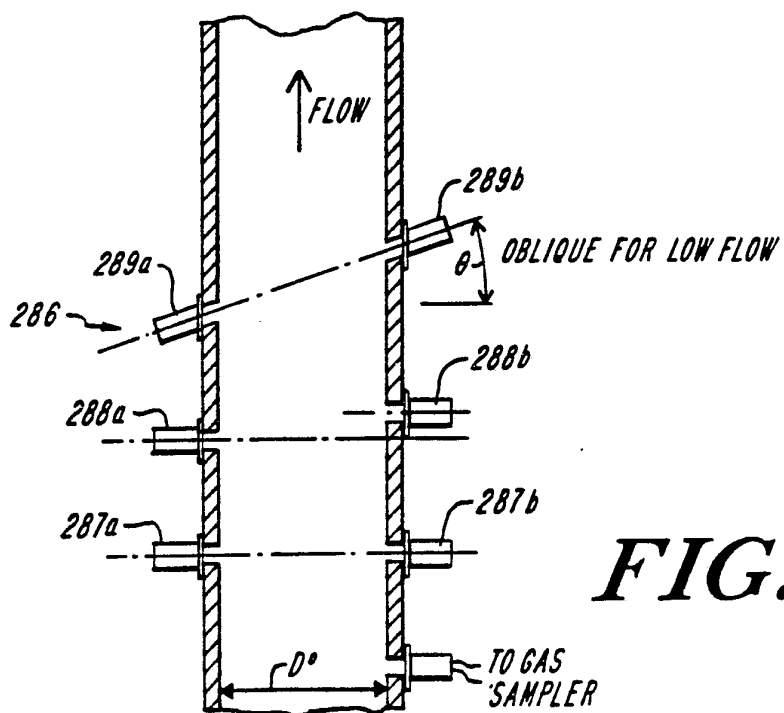

FIG. 25

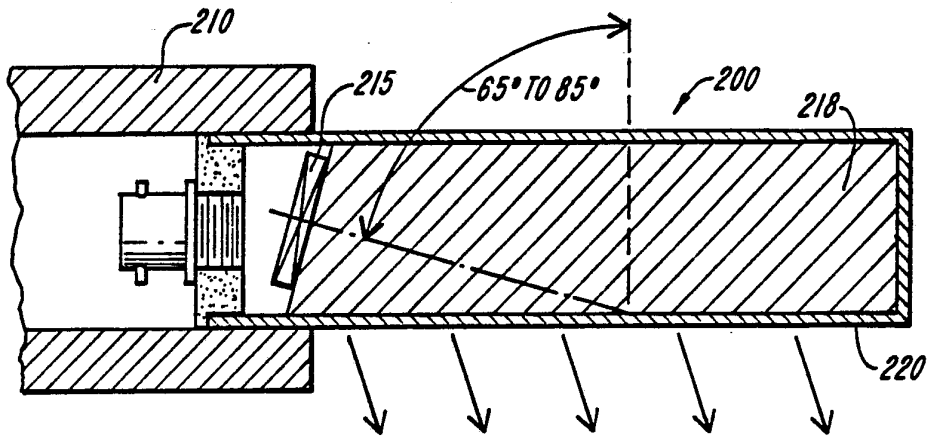

FIG. 26

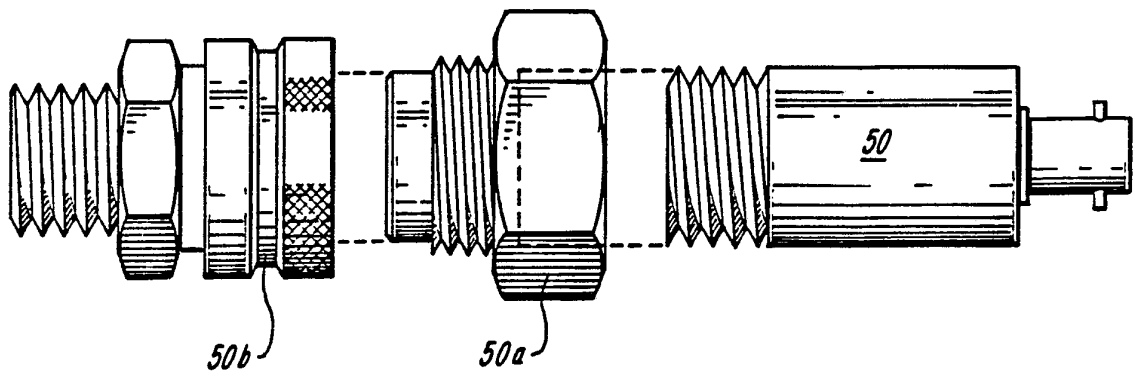



FIG. 27

INTERNATIONAL SEARCH REPORT

International Application No. PCT/US91/04563

| | | |
|--|--|-------------------------------------|
| I. CLASSIFICATION OF SUBJECT MATTER (if several classification symbols apply, indicate all) ⁶ | | |
| According to International Patent Classification (IPC) or to both National Classification and IPC IPC (5): G01F 1/66 U.S. CL: 73/861.27 | | |
| II. FIELDS SEARCHED | | |
| Minimum Documentation Searched ⁷ | | |
| Classification System | Classification Symbols | |
| U.S. CL. | 73/632,644,861.06,861.18,861.27,861.28 | |
| Documentation Searched other than Minimum Documentation to the Extent that such Documents are Included in the Fields Searched ⁸ | | |
| | | |
| III. DOCUMENTS CONSIDERED TO BE RELEVANT ⁹ | | |
| Category * | Citation of Document, ¹¹ with indication, where appropriate, of the relevant passages ¹² | Relevant to Claim No. ¹³ |
| A | US, A, 4,195,517 (KALINOSKI ET AL) 01 April 1980, see column 4, lines 48-63. | 44,45 |
| X | US, A, 4,227,407 (DROST) 14 October 1980, see column 5, lines 26-61. | 21 |
| X | US, A, 4,454,767 (SHINKAI ET AL) 19 June 1984, see column 3, lines 44-68. | 21 |
| X | US, A, 4,532,812 (BIRCHAK) 06 August 1985, see column 6, line 66 to column 7, line 13. | 30,42 |
| A | WO, A, W088/08,516 (Micronics Limited) 03 November 1988, see abstract. | 23,26 |
| <p>* Special categories of cited documents: ¹⁰</p> <p>"A" document defining the general state of the art which is not considered to be of particular relevance</p> <p>"E" earlier document but published on or after the international filing date</p> <p>"L" document which may throw doubts on priority claim(s) or which is cited to establish the publication date of another citation or other special reason (as specified)</p> <p>"O" document referring to an oral disclosure, use, exhibition or other means</p> <p>"P" document published prior to the international filing date but later than the priority date claimed</p> <p>"T" later document published after the international filing date or priority date and not in conflict with the application but cited to understand the principle or theory underlying the invention</p> <p>"X" document of particular relevance; the claimed invention cannot be considered novel or cannot be considered to involve an inventive step</p> <p>"Y" document of particular relevance; the claimed invention cannot be considered to involve an inventive step when the document is combined with one or more other such documents, such combination being obvious to a person skilled in the art.</p> <p>"Δ" document member of the same patent family</p> | | |
| IV. CERTIFICATION | | |
| Date of the Actual Completion of the International Search | Date of Mailing of this International Search Report | |
| 20 SEPTEMBER 1991 | 25 OCT 1991 | |
| International Searching Authority | Signature of Authorized Officer | |
| ISA/US |  CHARLES A. RUCHL | |