

A. SUNDH.
ELECTRIC CONTROLLER.
APPLICATION FILED JUNE 3, 1904.

FIG. 1.

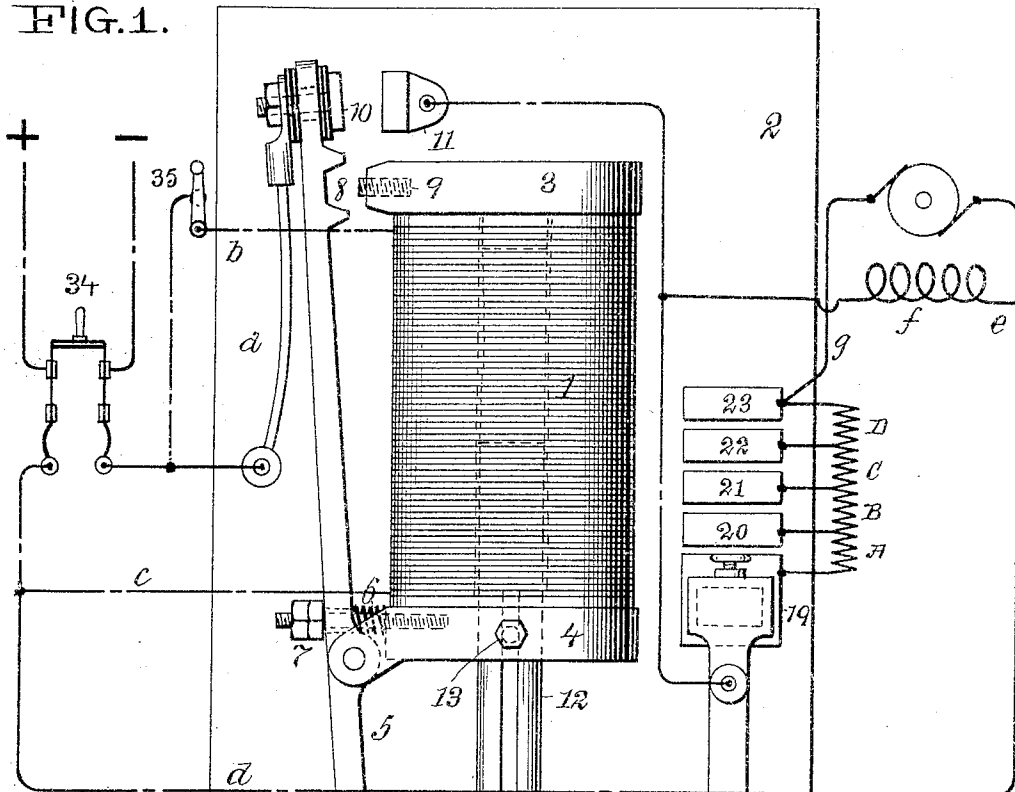
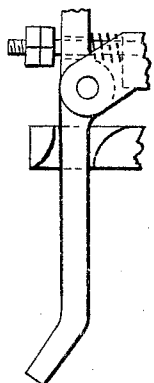

FIG. 2.



WITNESSES:

J. A. Van Wart
b. D. Morgan.

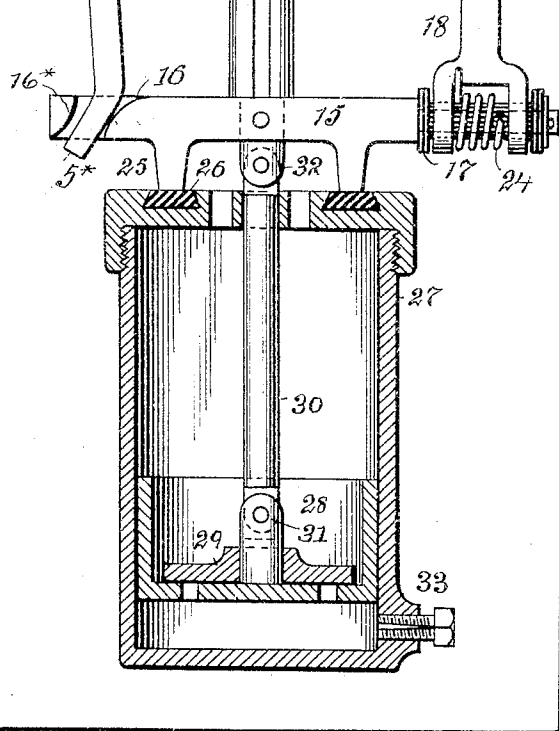
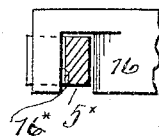

FIG. 3.



INVENTOR

August Sundh
BY *Paul Benjamin*
ATTORNEY

UNITED STATES PATENT OFFICE.

AUGUST SUNDH, OF YONKERS, NEW YORK, ASSIGNOR TO THE SUNDH
ELECTRIC COMPANY, A CORPORATION OF NEW YORK.

ELECTRIC CONTROLLER.

SPECIFICATION forming part of Letters Patent No. 779,447, dated January 10, 1905.

Application filed June 3, 1904. Serial No. 211,019.

To all whom it may concern:

Be it known that I, AUGUST SUNDH, of Yonkers, Westchester county, New York, have invented a new and useful Improvement in Electric Controllers, of which the following is a specification.

The invention relates to electromagnetic controlling apparatus for electric motors and other translating devices, and more particularly to the controller set forth in United States Letters Patent No. 733,563, granted to me July 14, 1903.

The object is to simplify the construction so that a single electromagnet may serve, by means of a single circuit-closer, to control circuit in the motor or other translating device and also actuate a sliding arm whereby resistances are cut out of or into the circuit of said device in starting and stopping the same.

The invention consists in the combinations more particularly pointed out in the claims.

In the accompanying drawings, Figure 1 is an elevation of my controller, showing the circuits and the motor controlled diagrammatically. Figs. 2 and 3 are detailed views in elevation and plan of the device for positively actuating the lever 5.

Similar characters of reference indicate like parts.

1 is a solenoid supported on the plate 2 between heads 3 and 4, which may be of magnetic material. Pivoted in lugs on the lower head 4 is a lever 5, which may also be of magnetic material. Passing loosely through said lever is a fixed rod 6, threaded to receive the stop-nuts 7, by adjusting which the extent of outward throw of lever 5 may be regulated. Near the upper end of lever 5 is a recess 8, having inclined sides and constructed to receive the edge of the upper head 3. In said edge is an adjustable screw 9, which serves to determine the extent of inward throw of lever 5. At the upper end of said lever is a pin 10 disposed in a sleeve of insulating material and having a broad face 10, which when the lever is suitably swung on its pivot may make con-

tact with the fixed terminal 11. To said pin is secured the circuit-wire *a*.

The movable core 12 of the solenoid 1 has a long guide-slot, through which passes the fixed pin 13 in lower head 4. Said core carries a cross-bar 15, having its upper edge 16 at one end rounded to meet the rounded lower extremity of lever 5. The other end of said bar is provided with a cylindrical flanged sleeve 17 of insulating material, which passes through openings in the forked lower end of the contact-arm 18. Said arm slides over the fixed contact-plates 19 20 21 22 23 and is held closely against said plates by the coiled spring 24, one end of which is secured to bar 15 and the other end bears against the outer surface of said arm. Between the plates 19 to 23 are resistances A B C D. On the lower side of bar 15 are projections 25, constructed to meet elastic cushions 26, seated in the cover of the dash-pot cylinder 27. Said cylinder contains a piston 28, having air-openings covered by a loose valve 29, through which valve the piston-rod 30 passes. Said rod is jointed at 31 and again at 32, where it is connected to the lower end of the solenoid-core 12. Air-pressure in the dash-pot may be regulated by the adjustable split screw 33, seated in the lower portion of the cylinder 27.

The circuits are as follows: One branch proceeds from main terminal, when the hand-switch 34 is closed, by wire *c* to and through the solenoid-coil, by wire *b* to switch 35 and to main terminal. Another branch proceeds by wire *d* to the point *e*, where the circuit divides. One part proceeds through the motor-field *f* to the fixed contact-terminal 11 and so by wire *a* (circuit being closed by lever 5) to main terminal. The other part proceeds through the motor-armature *g* to the contact-plates 19 to 23 and resistances A B C D to arm 18 and so by wire *h* to terminal 11.

The operation is as follows: The switches 34 35 being closed, the solenoid 1 is energized, raises its core, and thus by bringing the rounded edge 16 of the opening in the bar 15 against the bent lower end 5* of lever 5 moves

the plate 10 on said lever into contact with the fixed terminal 11. Circuit is thus established directly through the motor-field f and by way of all the resistances A B C D through the motor-armature g . As the core continues to rise the said resistances are successively cut out of circuit, and the motor gradually increases in speed until running speed is attained, when the arm 18 comes to rest on plate 23. The bar 15 holds the circuit mechanically closed at 10 11. When the circuit is broken at switch 34 to stop the motor, the arm 18 descends, cutting the resistances successively into circuit, and finally when the rounded edge 16* on the opposite side of the opening in bar 5 meets the outer side of the bent lower portion 5* of lever 5 said lever is positively moved outwardly, thus interrupting the circuit at 10 11. The dash-pot operates in the usual way to prevent shock and sudden movement of the parts.

I claim—

1. The combination of resistances, a sliding arm constructed to cut the same into and out of circuit, an independent circuit-closer in circuit with said resistances and arm, a single electromagnet, and means controlled by said magnet for mechanically closing said circuit-closer and actuating said arm to vary said resistances.

2. The combination of resistances, a sliding arm constructed to cut the same into and out of circuit, an independent circuit-closer in circuit with said resistances and arm, a single electromagnet, and means controlled by said magnet for, (first,) mechanically closing said circuit-closer; (second,) holding the same in closed position, and, (third,) actuating said arm to vary said resistances.

3. A solenoid, a core, a series of fixed contacts and intermediate resistances, an arm actuated by said core to slide over said contacts and a separate circuit-closer controlled by

said core and constructed to close circuit through said contacts, resistances and sliding arm.

4. A solenoid, a core, a series of fixed contacts and intermediate resistances, an arm actuated by said core to slide over said contacts and a separate circuit-closer mechanically operated by said core and constructed to close circuit through said contacts, resistances and sliding arm.

5. A solenoid, a core, a bar carried by said core, an arm carried by said bar, a series of fixed contacts and resistances traversed by said arm, and a swinging circuit-closing lever constructed to be mechanically operated by said bar to open and close circuit through said arm, contacts and resistances.

6. A solenoid, a core, a pivoted circuit-closing lever disposed at one side of said solenoid, a series of fixed contacts and resistances at the other side, an arm constructed to slide over said contacts and a transverse bar supported by the solenoid-core and carrying said arm at one end, and having its opposite end constructed to meet and actuate said lever; the said lever being constructed to close circuit through said contacts, resistances and arm.

7. A solenoid, a core, a series of fixed contacts and intermediate resistances, an arm actuated by said core to slide over said contacts, a separate circuit-closer constructed to control circuit through said contacts, resistances and sliding arm and means for positively actuating said circuit-closer to open and close said circuit.

In testimony whereof I have signed my name to this specification in the presence of two subscribing witnesses.

AUGUST SUNDH.

Witnesses:

WM. H. SIEGMAN,
I. A. VAN WART.