

[54] LIGHTING SCENE CONTROL PANEL AND CONTROL CIRCUIT

[75] Inventors: Walter Zaharchuk, Macungie; Joel S. Spira, Coopersburg, both of Pa.

[73] Assignee: Lutron Electronics Co., Inc., Coopersburg, Pa.

[21] Appl. No.: 526,321

[22] Filed: Aug. 25, 1983

[51] Int. Cl.⁴ H02P 5/00

[52] U.S. Cl. 315/295; 315/291; 315/208

[58] Field of Search 315/295, 208, 291, 294, 315/297; 362/125, 136, 374; 338/117, 125, 160

[56] References Cited

U.S. PATENT DOCUMENTS

3,221,214	11/1965	Wolf et al.	315/294 X
4,144,478	3/1979	Nuver	315/291
4,255,781	3/1981	Plemmons et al.	362/374
4,274,074	6/1981	Sakamoto	338/160

Primary Examiner—David K. Moore
 Attorney, Agent, or Firm—Ostrolenk, Faber, Gerb & Soffen

[57] ABSTRACT

A plurality of groups of linearly adjustable control potentiometers control respective lights of a given light scene in a given area. A particular group of potentiometers to control the scene is selected by a respective push-button switch on the control panel. Each of the potentiometer control sliders has an LED which is illuminated when its group of potentiometers is selected. Each of the control potentiometers controls a respective dimmer control circuit. Respective fader circuits are connected to each dimmer control circuit. All fader circuits are adjusted by a single potentiometer having a logarithmic response function. The single adjustment potentiometer is mounted on the control panel. All of the dimmer control circuits are remotely located from the control panel. The control panel is covered by a solid cover or a translucent cover through which only illuminated LEDs on the potentiometer sliders are visible. Thus, the group of potentiometers controlling the scene is visible and the adjustment position of each individual potentiometer of the group relative to the other potentiometers of the group is visible.

24 Claims, 4 Drawing Figures

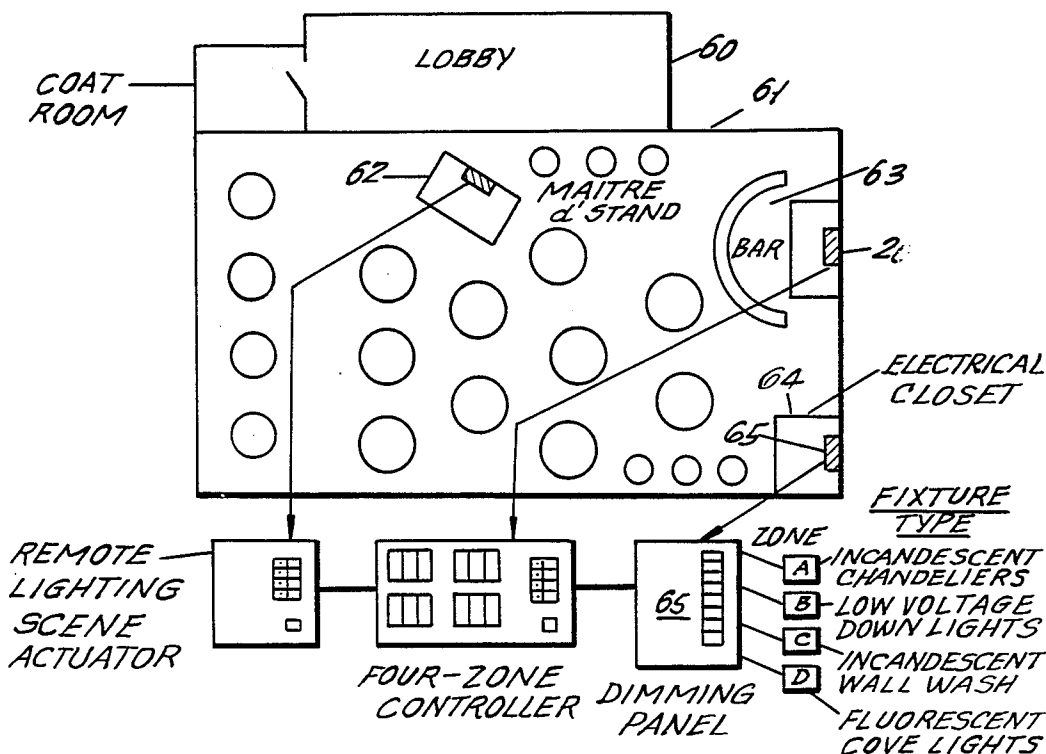

FIG. 1.

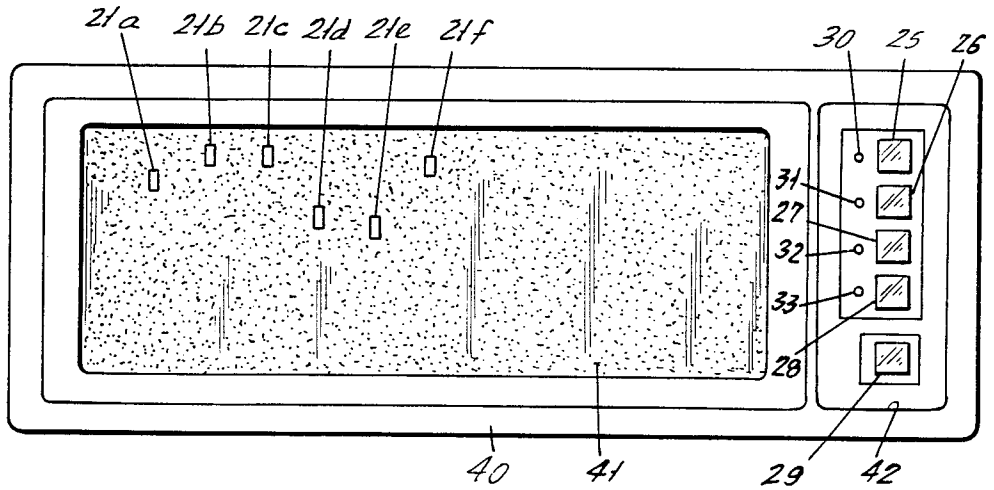
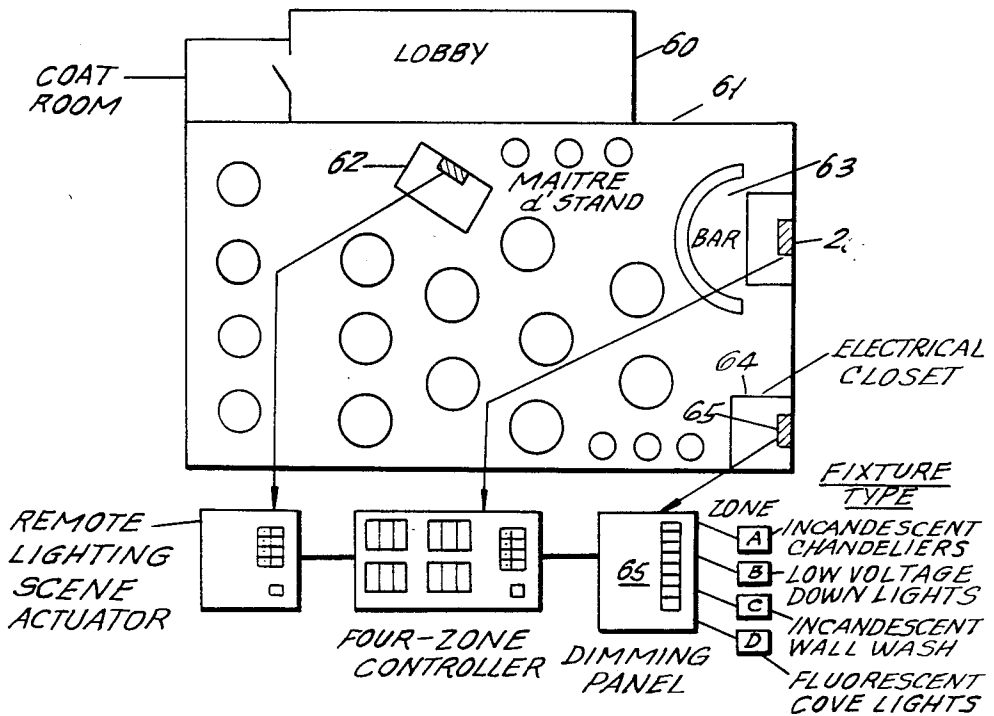

FIG. 3.



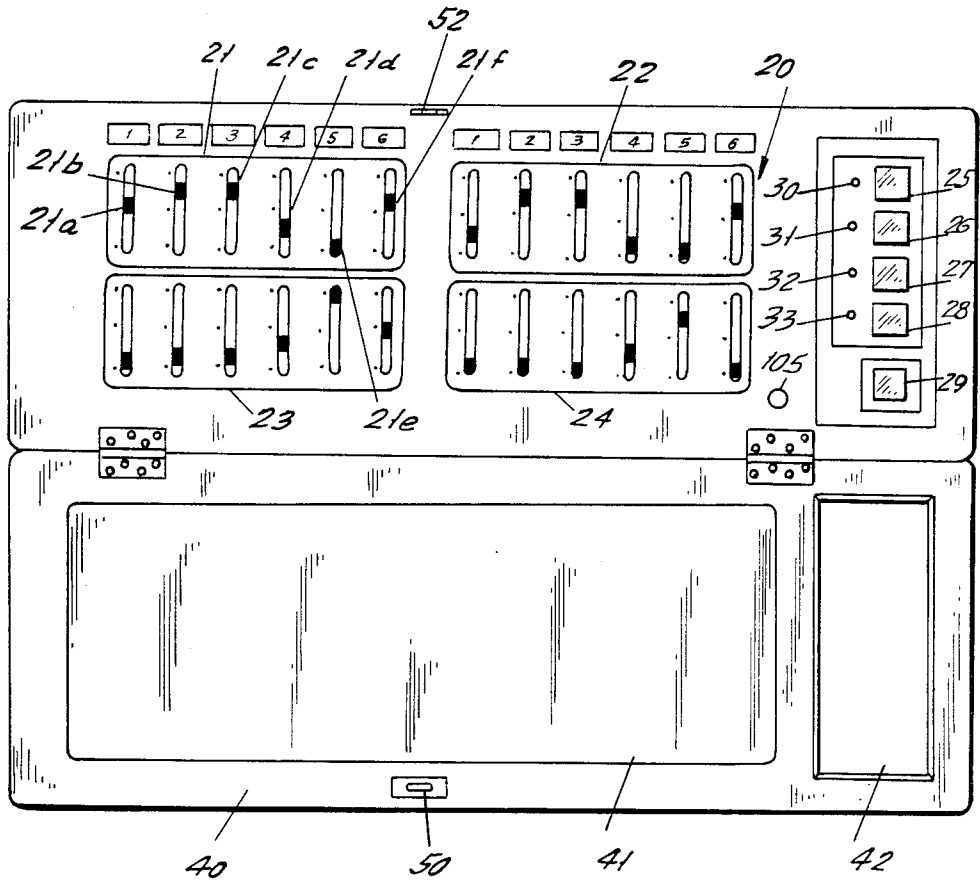
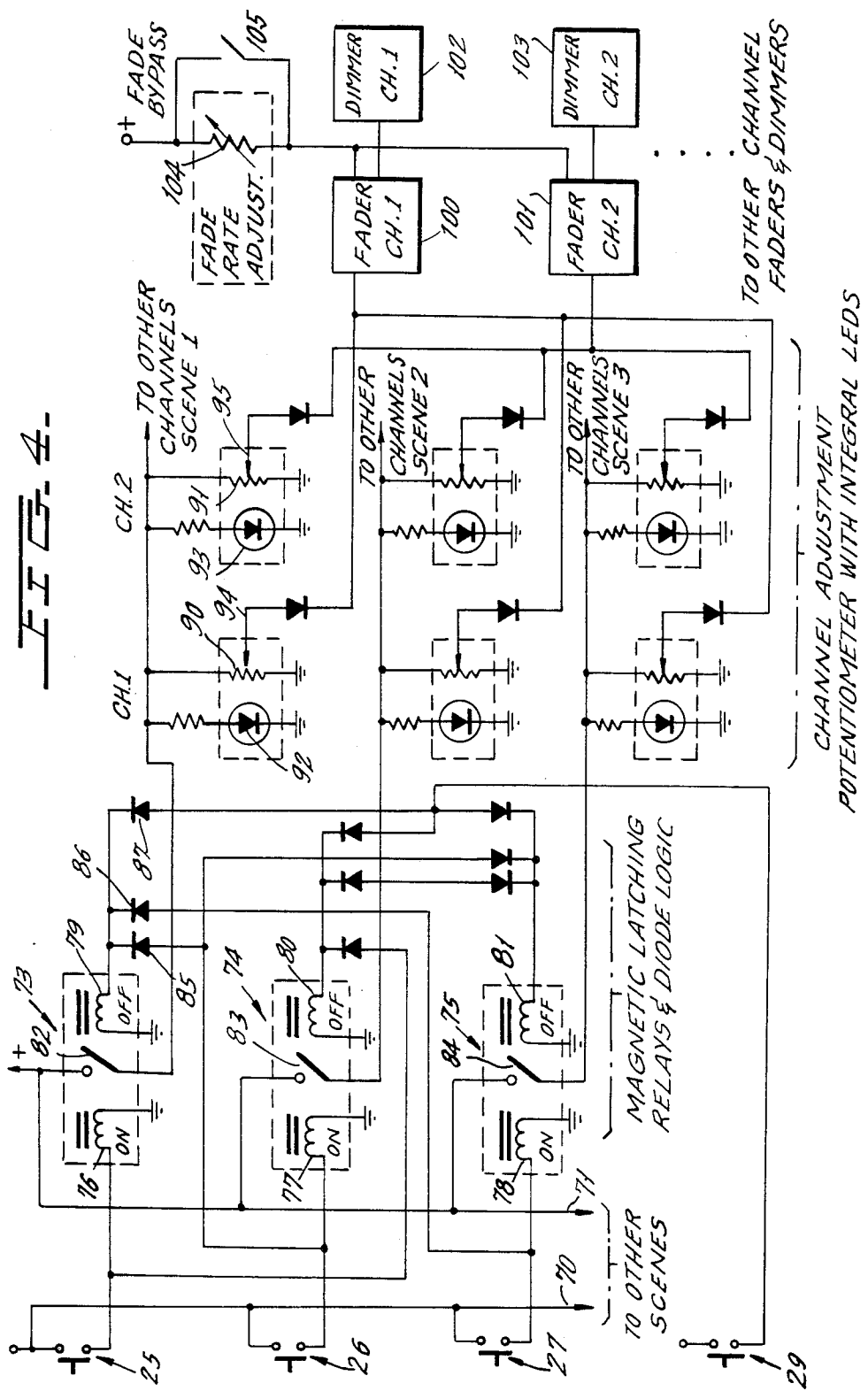

FIG. 2.



LIGHTING SCENE CONTROL PANEL AND CONTROL CIRCUIT

BACKGROUND OF THE INVENTION

This invention relates to lighting scene controls, and more specifically relates to a novel circuit and panel for such control systems.

Lighting control systems are known wherein groups of lights within a room can be individually dimmed by different relative amounts and, upon the pressing of an appropriate switch, one of a plurality of dimming scenes which is preset can be automatically selected. Past arrangements to obtain this result frequently employ rotary potentiometers, with all dimming equipment and control equipment contained at the same location. This location frequently was removed from the area being lighted so that adjustment of the various lights in the area for different scenes was complicated. Moreover, in prior art arrangements it was difficult to determine the relative adjustment of potentiometers of given groups of controls which define respective single lighting scenes relative to one another.

It is also known in the prior art to provide fade circuit means to control the fading of the light from one adjustment level to another as the lighting scene is changed. Each fade control circuit had a respective fade rate adjustment which required individual adjustment. These adjustments did not account for desirable changes in fade speed, depending on the portion of the fade rate range being used.

BRIEF DESCRIPTION OF THE INVENTION

A novel control system and control panel is provided in accordance with the invention where each lighting scene for a given set of light fixtures is controlled by a corresponding group of a plurality of linearly adjustable slide potentiometer controls which are arranged parallel to one another and move coextensively with one another. Push-button switching means is provided to select a particular preset group of potentiometer controls which control the dimming level of the lighting fixtures. The dimmer control circuitry may be located remotely of the control panel so that the relatively bulky control circuit can be contained in a suitable remotely positioned electrical cabinet while the control panel can be located conveniently in the room being controlled or illuminated.

Each of the potentiometer sliders carries a respective viewable LED or other suitable light source wherein only the LEDs of the sliders which have been switched to control the lighting fixtures are illuminated, thus indicating which group is controlling the scene and further indicating the relative adjustment of the various potentiometers within the group relative to one another. The control panel is enclosed by either an opaque cover or a translucent cover which makes visible only the illuminated LEDs.

While the LEDs are preferably on the slider, other arrangements are possible to indicate the adjustment level of the potentiometer. For example, circuitry may be provided for a stationary LED associated with a potentiometer to control the output light intensity, flash frequency, color or the like as a function of potentiometer position.

If desired, such LEDs can be fixed to any movable adjustment member, including a rotary potentiometer knob or shaft, to visually indicate the selection of the

potentiometer for a control function and the setting of the potentiometer. The LED in this case can also be stationarily mounted relative to the rotary or other adjustment member and can indicate selection and/or adjustment position of the adjustment member by control of light intensity, flash frequency, color or the like.

As a further feature of the invention, a fade circuit is provided for each of the remotely located dimmer controls and a novel common adjustment potentiometer is made available for each of the fade circuits, which common adjustment potentiometer is located in the control panel. The push-button switches which are used to select a desired scene operate in conjunction with magnetic latching relays which activate the appropriate group of control potentiometers. Also provided are diode steering logic circuits which steer the appropriate potentiometer outputs to the fader inputs associated with each circuit being individually controlled.

The use of linear potentiometers as the adjustment potentiometer enables logical physical grouping of a relatively large number of lighting zones or of individually controlled light fixtures in a relatively small control panel area. The linear controls will occupy considerably less area than even miniature rotary potentiometers which require relatively large knobs to enable easy, accurate adjustment with observation of the position of the control.

A transconductance amplifier fader circuit is also employed to allow the fading function to be implemented with relatively few parts compared to standard fader circuits. The use of a single fader rate adjustment potentiometer for the multiple faders further reduces space requirements and simplifies setup times since only one fader adjustment must be made rather than one for each channel.

The fader rate adjustment is designed to have a logarithmic response of fade rate versus adjustment potentiometer rotation angle so that ease of adjustment to desired rates is preserved over the entire adjustment range. A fade bypass circuit is also included to eliminate the fade functions upon initial turn-on of the system from a full off condition so that the user does not have to wait for lights to fade up slowly from a zero output.

BRIEF DESCRIPTION OF THE DRAWINGS

FIG. 1 is an elevation view of the front panel cover of a control system of the present invention.

FIG. 2 shows the panel of FIG. 1 opened to expose the front control panel.

FIG. 3 is a plan view of a room which employs the novel system of the invention.

FIG. 4 is a circuit diagram of the present invention.

DETAILED DESCRIPTION OF THE DRAWINGS

Referring first to FIGS. 1 and 2, the control panel illustrated has an internal panel 20 (FIG. 2) which contains four groups 21, 22, 23 and 24 of linear potentiometers. Each potentiometer has a slider control which extends through slots in the panel 20 so that the sliders can be manually moved up and down in FIG. 2. The protruding ends of the sliders are seen in FIG. 2 as illuminated end regions 21a through 21f which carry and are illuminated by respective LEDs. Similar slider handles which also contain LEDs which may be illuminated extend through the panel for each of groups 22, 23

and 24. Note in FIG. 1 that only LEDs 21a through 21f are illuminated.

Next contained in the panel 20 are a plurality of touch-button switches 25, 26, 27 and 28, each of which is operable to activate a respective one of groups 21, 22, 23 and 24, respectively. A further touch button 29 is provided which is operable to turn off the entire system upon its depression. Four LEDs 30, 31, 32 and 33 are associated with touch buttons 25, 26, 27 and 28, respectively and are illuminated when their respective touch button is pressed in order to cause their respective group 21, 22, 23 or 24 to assume scene control, as will be later described.

A panel cover 40 is hinged to control panel 20 and contains a smoked translucent window 41 and a slot 42 therein. When the cover 40 is closed, the touch buttons 25, 26, 27 and 28 and their respective pilot LEDs 30, 31, 32 and 33 are exposed through slot 42. The smoked translucent window 41, however, covers the potentiometer sliders of groups 21, 22, 23 and 24. Thus, as schematically shown in FIG. 1, if touch button 25 is depressed to activate the potentiometers of group 21, the LEDs 21a through 21f are visible through the smoked window 41. Thus, one can visually observe, first from the illumination of LED 30 and, second, from the illumination of the LEDs 21 through 21f, that the lighting scene is being controlled by group 21. One can also observe the relative adjustment of the various channels or the relative dimming adjustment of the individually controlled fixtures of the scene relative to one another by observing the position of the LEDs 21a through 21f relative to one another.

If desired, a hidden security latch, including latch members 50 and 52 in FIG. 2, can be provided to hold latch cover 40 closed and deter unauthorized tampering with preset lighting scenes.

FIG. 3 illustrates the manner in which the novel system of the invention can be applied, for example, to a restaurant. The restaurant of FIG. 3 contains a lobby 60 and main dining room 61. Within the main dining room there may be a reception stand 62, a bar area 63 and a remote electrical enclosure or closet 64. The lighting within the restaurant room 61 may include the following four different types of lights, hereinafter referred to as "zones" or "channels" or "groups":

- (A) chandeliers
- (B) low voltage down lights
- (C) incandescent wall wash
- (D) fluorescent cove lights

Each of the above lighting zones should be adjusted differently at different times during the day. For example, different settings should be made for breakfast, lunch, dinner or cocktails. These desired adjustment might be according to the following table:

Scene	Restaurant Function	Zone			
		A	B	C	D
1	Breakfast	70%	80%	60%	90%
2	Luncheon	40%	70%	80%	90%
3	Dinner	20%	40%	40%	60%
4	Cocktails	10%	20%	20%	40%

The control panel of the type shown in FIGS. 1 and 2 can be employed to preset these adjustments. More specifically, each of the lighting fixture groups A, B, C and D is controlled from circuitry contained in a relatively large dimming panel schematically shown as panel 65 which is contained in a remote electrical closet

64. The control panels of FIGS. 1 and 2, however, are conveniently located at region 20 in the bar area 63. A remote lighting scene activator serving the function only of switches 25 through 29 of FIGS. 1 and 2 can be located at the reception area 62. If desired, manual potentiometer or other adjustments can be located with or independently of the remote lighting scene activator to enable manual adjustment of any channel or circuit without changing the preset pattern of the main controller.

The dimming levels specified in the table for scene 1 are adjusted as by a lighting expert by adjustment of the linear adjustment potentiometers of group 21. The relative dimming percentages which are then obtained can be instantly recalled by depression of the push button 25 as will be later described. Each of the settings for scenes 2, 3 and 4 of the above table are similarly made in potentiometer groups 22, 23 and 24, respectively. Restaurant personnel will never need to adjust the sliders to establish the lighting levels.

Referring next to FIG. 4, there is shown therein a circuit diagram, partially in block form, of the control circuit for carrying out the control system shown in FIGS. 1 and 2. For the sake of simplicity, only three scene circuits are shown and only two channels are shown for each of the three scenes. Thus, in FIG. 4 there is schematically illustrated push-button switches 25, 26, 27 and 29 which are momentary close switches. These switches are connected in series with an appropriate d.c. voltage source shown as having a positive d.c. terminal throughout the circuit of FIG. 4. Any number of scenes can be used in the circuit of FIG. 4 where additional scene circuits are added onto the extending lines 70 and 71.

Each of switches 25, 26 and 27 is connected to operate conventional commercially available magnetic latching relays shown as relays 73, 74 and 75, respectively, each of which contains on-coils 76, 77 and 78, respectively, and off-coils 79, 80 and 81, respectively. Energization of these coils will open and close the relay contacts 82, 83 and 84, respectively. A novel diode logic configuration is employed including three diodes for each off-coil 79, 80 and 81 to ensure that only one relay contact is closed at any instant. By way of example, three diodes 85, 86 and 87 are employed for off-coil 79. If any one of contacts 26, 27 or 29 is closed, the coil 79 will be energized and contact 82 will open. Contact 82, however, remains closed following the closure of only switch 25. This circuit ensures that only one scene can be presented by depression of one of the push buttons 25 to 27.

The contacts of each of the magnetic latching relays are then connected to the individual channels of the group of controlled potentiometers associated with the scene selection push buttons 25, 26 or 27, respectively. Thus, contact 82 is connected to two channels, each containing linear potentiometers 90 and 91, respectively, as well as other identical channels depending upon the number of channels there are provided in the group. For example, in the arrangement of FIG. 2, there would be six channels with potentiometers 90 and 91 corresponding to the potentiometers containing sliders 21a and 21b in FIG. 2.

Also provided for each of the potentiometer sliders 90 and 91 are the LEDs 92 and 93, respectively, which, as shown in FIG. 2, are fixed directly atop each manually accessible slider.

The output at the potentiometer taps **94** and **95** **95** of FIG. **4** are then connected to the inputs of fader circuits **100** and **101**, respectively, where the number of fader circuits will correspond to the total number of zones or channels for each scene. In the case of the arrangement of FIG. **2**, there would be six fader channels. The output of each of the fader circuits are then connected to dimmer control circuits **102** and **103**, respectively, where these dimmer control circuits can take the form, for example, of the circuit shown in U.S. Pat. No. 4,350,935.

In order to control the time constant of the fader circuits **100** and **101**, a common fader rate adjustment potentiometer **104** is provided which adjusts the input to the fader circuits **100** and **101**. As described previously, the adjustment potentiometer **104** may be a rotational potentiometer, and is designed to have a logarithmic response of fade rate versus potentiometer rotation. This simplifies the adjustment of each channel over the entire adjustment range of the system.

In order to bypass the fade mode of operation, a parallel relay switch **105** is provided which is arranged to be closed by a suitable circuit (not shown) for at least a few seconds following the initial turn-on of the system so that the user does not have to wait for the lights to fade from an off condition to their set condition.

Each of the known dimmer control circuits **102** and **103** as well as those of the other channels controls their respective lighting fixtures in the manner described in the above-noted patent. Significantly, these dimmer control circuits can be located in the dimming panel **65** located in the electrical closet of FIG. **3**. This simplifies the equipment needed at the control location and permits the use of an architecturally pleasing control panel design. Note further that the fader control potentiometer **105** is also contained in the control panel **20** of FIG. **2** and permits fade rate adjustment between scenes from 1 to 60 seconds to be adjusted by a screw driver.

It will be observed that the novel use of magnetic latching relays and diode logic requires only a momentary pulse of energy on one coil to turn on a group and on another coil to turn the group off. This eliminates the electronic latching circuitry which was previously required to perform this memory function. Note also that the novel magnetic latch system retains its set state even during a power failure so that the system will return to its last set state automatically upon the return of power without the need for operator action or extra support circuitry such as batteries or the like.

In order to turn the system off, it is necessary only to touch the momentary switch **29** which then deenergizes all of the magnetic latch off-coils. When all scenes are deenergized by the off button, other logic circuitry (not shown) will cause the power feed to the dimmers to be interrupted so that the lights will immediately extinguish.

Although the present invention has been described in connection with a preferred embodiment thereof, many variations and modifications will now become apparent to those skilled in the art. It is preferred, therefore, that the present invention be limited not by the specific disclosure herein, but only by the appended claims.

What is claimed is:

1. A lighting scene control system comprising: a plurality of groups of potentiometer controls, each of said groups mounted within a distinct respective area of a control panel, each of said groups including a plurality of individual linearly movable potentiometer adjust-

ment members; each of said groups being physically spaced from one another and being spatially distinct from one another; a plurality of dimmer control circuit means; a plurality of output light means; said plurality of dimmer control circuit means connected to respective ones of said plurality of output light means and being operable to dim the output of their respective output light means; corresponding ones of said individual movable adjustment members of each of said groups being connectable to corresponding ones of said dimmer control circuit means; the output of each of said plurality of output light means being dependent upon the linear position of said adjustment member of said respective potentiometer connected to its respective dimmer control circuit means; a plurality of switches mounted on said control panel corresponding in number to the number of said groups; each of said switches operatively connected between said plurality of dimmer control circuit means and respective ones of said potentiometers of said respective groups, each of said switches being operable between a first position, in which said potentiometers of only its respective group is connected to control respective ones of said output light means independently of all other potentiometers of said other groups, and a second position in which the potentiometers of its respective group are disconnected from operative control of said output light means; whereby each of said adjustment members of each of said groups is settable to a given position such that a different given pattern of light dimming for each of said output light means can be provided in response to operation of different ones of said switches to their respective first position.

2. The lighting control system of claim 1 wherein each of said linearly movable potentiometer adjustment members of each of said groups is arranged to move independently in laterally spaced, parallel, coextensive paths.

3. The lighting control system of claim 1 wherein each of said adjustment members has an LED associated therewith; and circuit means connected between said switches and said respective groups of potentiometers whereby said LEDs of only said group corresponding to one of said switches which is moved to its said first position are illuminated, thereby illuminating only that group of LEDs which controls the lighting scene and whereby that latter group and the individual position of each linearly movable adjustment member of said latter group is visually identified.

4. The light control system of claim 3 wherein the position of each of said linearly movable adjustment members between their end positions is functionally related to the output dimming of their respective output light means.

5. The light control system of claim 1 wherein said dimmer control circuit means is mounted remotely of said control panel.

6. The light control system of claim 1 which further includes respective fader control circuit means connected to respective ones of said dimmer control circuit means for controlling the rate of change of output of respective ones of said output light means as said switches are operated and apply different dimming outputs to said output light means.

7. The light control system of claim 6 which includes a common fade control member for simultaneously and logarithmically controlling the time constant of each of said fade circuits as a function of the movement of said

control member; said common fade control member mounted on said control panel.

8. The lighting control system of claim 2 wherein each of said adjustment members has an LED associated therewith; and circuit means connected between said switches and said respective groups of potentiometers whereby said LEDs of only said group corresponding to one of said switches which is moved to its said first position are illuminated, thereby illuminating only that group of LEDs which controls the lighting scene and whereby that latter group and the individual position of each linearly movable adjustment member of said latter group is visually identified.

9. The light control system of claim 8 wherein the position of each of said linearly movable adjustment members between their end positions is functionally related to the output dimming of their respective output light means.

10. The light control system of claim 9 which further includes respective fader control circuit means connected to respective ones of said dimmer control circuit means for controlling the rate of change of output of respective ones of said output light means as said switches are operated and apply different dimming outputs to said output light means.

11. The light control system of claim 10 which includes a common fade control member for simultaneously and logarithmically controlling the time constant of each of said fade circuits as a function of the movement of said control member; said common fade control member mounted on said control panel.

12. The light control system of claim 9 wherein said dimmer control circuit means is mounted remotely of said control panel.

13. The light control system of claim 11 wherein said dimmer control circuit means is mounted remotely of said control panel.

14. The system of claim 3 which further includes a control panel window covering at least the portion of said control panel containing said groups of adjustment members; said control panel window being translucent whereby only the illuminated LEDs associated with said adjustment members are visible through said control panel window.

15. The lighting control system of claim 14 wherein said linearly movable potentiometer adjustment members of each of said groups are arranged to move independently in laterally spaced, parallel, coextensive paths.

16. The light control system of claim 15 wherein the position of each of said linearly movable adjustment members between their end positions is functionally related to the output dimming of their respective output light means.

17. The light control system of claim 16 wherein said dimmer control circuit means is mounted remotely of said control panel.

18. A lighting scene control system comprising: a plurality of groups of potentiometer controls, each of said groups mounted within a distinct respective area of a control panel, each of said groups including a plurality of individual potentiometer adjustment members; each of said groups being physically spaced from one another and being spatially distinct from one another; a plurality of dimmer control circuit means; a plurality of output

light means; said plurality of dimmer control circuit means connected to respective ones of said plurality of output light means and being operable to dim the output of their respective output light means; corresponding ones of said individual adjustment members of each of said groups being connectable to corresponding ones of said dimmer control circuit means; the output of each of said plurality of output light means being dependent upon the position of said adjustment member of said respective potentiometer connected to its respective dimmer control circuit means; a plurality of switches mounted on said control panel corresponding in number to the number of said groups; each of said switches operatively connected between said plurality of dimmer control circuit means and respective ones of said potentiometers of said respective groups, each of said switches being operable between a first position, in which said potentiometer of only its respective group is connected to control respective ones of said output light means independently of all other potentiometers of said other groups, and a second position in which the potentiometers of its respective group are disconnected from operative control of said output light means; whereby each of said adjustment members of each of said groups is settable to a given position such that a different given pattern of light dimming for each of said output light means can be provided in response to operation of different ones of said switches to their respective first position.

19. The lighting control system of claim 18 wherein each of said adjustment members has an LED associated therewith; and circuit means connected between said switches and said respective groups of potentiometers whereby said LEDs of only said group corresponding to one of said switches which is moved to its said first position are illuminated, thereby illuminating only that group of LEDs which controls the lighting scene and whereby that latter group and the individual position of each adjustment member of said latter group is visually identified.

20. The light control system of claim 19 wherein the position of each of said adjustment members between their end positions is functionally related to the output dimming of their respective output light means.

21. The system of claim 19 which further includes a control panel window covering at least the portion of said control panel containing said groups of adjustment members; said control panel window being translucent whereby only the illuminated LEDs associated with said adjustment members are visible through said control panel window.

22. The light control system of claim 18, 19, 20 or 21, wherein each of said LEDs is fixed to and movable with its said respective adjustment member.

23. The light control system of claims 3, 4, 8, 9, 10, 15, 16, 19, 20 or 21 in which each of said LEDs has a brightness level associated therewith, said brightness level of each said LEDs being functionally related to the output dimming of its respective output means.

24. The light control system of claim 22 in which each said LEDs has a brightness level associated therewith, said brightness level of each said LEDs being functionally related to the output dimming of its respective output means.

* * * * *

UNITED STATES PATENT AND TRADEMARK OFFICE
CERTIFICATE OF CORRECTION

PATENT NO. : 4,575,660 Page 1 of 3
DATED : March 11, 1986
INVENTOR(S) : Walter ZAHARCHUK, Joel S. SPIRA

It is certified that error appears in the above-identified patent and that said Letters Patent is hereby corrected as shown below:

Column 6, line 15, change "switches mounted on" to
--switch means accessible at--.
means--. line 17, change "switches" to --switch
means--. line 20, change "switches" to --switch
means--. line 32, change "switches" to --switch

Column 6, line 42, change "switches" to --switch
means--. line 44, change "switches" to --switch
means--.

Column 6, line 63, change "switches" to --switch
means--.

Column 7, line 6, change "switches" to --switch
means--. line 8, change "switches" to --switch
means--.

UNITED STATES PATENT AND TRADEMARK OFFICE
CERTIFICATE OF CORRECTION

PATENT NO. : 4,575,660 Page 2 of 3
DATED : March 11, 1986
INVENTOR(S) : Walter ZAHARCHUK, Joel S. SPIRA

It is certified that error appears in the above-identified patent and that said Letters Patent is hereby corrected as shown below:

Column 7, line 24, change "switches" to --switch
means--.

Column 8, line 11, change "switches" to --switch
means--.

line 12, change "mounted on" to
--accessible at--.

line 13, change "switches" to --switch
means--.

line 17, change "switches" to --switch
means--.

line 28, change "switches" to --switch
means--.

UNITED STATES PATENT AND TRADEMARK OFFICE
CERTIFICATE OF CORRECTION

PATENT NO. : 4,575,660

Page 3 of 3

DATED : March 11, 1986

INVENTOR(S) : Walter ZAHARCHUK, Joel S. SPIRA

It is certified that error appears in the above-identified patent and that said Letters Patent is hereby corrected as shown below:

Column 8, line 33, change "switches" to --switch
means--.
line 35, change "switches" to --switch
means--.

Signed and Sealed this

Twenty-sixth Day of August 1986

[SEAL]

Attest:

DONALD J. QUIGG

Attesting Officer

Commissioner of Patents and Trademarks