

(19) World Intellectual Property Organization
International Bureau



(43) International Publication Date
1 July 2010 (01.07.2010)

(10) International Publication Number
WO 2010/074945 A1

(51) International Patent Classification:
H01H 31/00 (2006.01) *H02G 7/04* (2006.01)

(74) Agent: **TYCO ELECTRONICS CORPORATION**; 309
Constitution Drive, M/S R34-2A, Menlo Park, California
94025-1164 (US).

(21) International Application Number:
PCT/US2009/067049

(81) Designated States (unless otherwise indicated, for every
kind of national protection available): AE, AG, AL, AM,
AO, AT, AU, AZ, BA, BB, BG, BH, BR, BW, BY, BZ,
CA, CH, CL, CN, CO, CR, CU, CZ, DE, DK, DM, DO,
DZ, EC, EE, EG, ES, FI, GB, GD, GE, GH, GM, GT,
HN, HR, HU, ID, IL, IN, IS, JP, KE, KG, KM, KN, KP,
KR, KZ, LA, LC, LK, LR, LS, LT, LU, LY, MA, MD,
ME, MG, MK, MN, MW, MX, MY, MZ, NA, NG, NI,
NO, NZ, OM, PE, PG, PH, PL, PT, RO, RS, RU, SC, SD,
SE, SG, SK, SL, SM, ST, SV, SY, TJ, TM, TN, TR, TT,
TZ, UA, UG, US, UZ, VC, VN, ZA, ZM, ZW.

(22) International Filing Date:
8 December 2009 (08.12.2009)

(25) Filing Language: English

(26) Publication Language: English

(30) Priority Data:
12/342,113 23 December 2008 (23.12.2008) US

(71) Applicant (for all designated States except US): **TYCO
ELECTRONICS CORPORATION** [US/US]; 1050
Westlakes Drive, Berwyn, Pennsylvania 19312 (US).

(84) Designated States (unless otherwise indicated, for every
kind of regional protection available): ARIPO (BW, GH,
GM, KE, LS, MW, MZ, NA, SD, SL, SZ, TZ, UG, ZM,
ZW), Eurasian (AM, AZ, BY, KG, KZ, MD, RU, TJ,
TM), European (AT, BE, BG, CH, CY, CZ, DE, DK, EE,
ES, FI, FR, GB, GR, HR, HU, IE, IS, IT, LT, LU, LV,
MC, MK, MT, NL, NO, PL, PT, RO, SE, SI, SK, SM,
TR), OAPI (BF, BJ, CF, CG, CI, CM, GA, GN, GQ, GW,
ML, MR, NE, SN, TD, TG).

(72) Inventors; and
(75) Inventors/Applicants (for US only): **MITCHELL,
Steven** [US/US]; 2627 Sherrie Lane, Thompsons Station,
Tennessee 37179 (US). **GREGORY, Owen** [NZ/US];
3016 Sawyers Mill Drive, Apex, North Carolina 27502
(US). **LADIN, Dmitry** [CA/CA]; Suite 308, 9944 Keele
Street, Vaughan, Ontario L6A 3Z4 (CA). **JOHNSON,
Barry** [CA/CA]; 1 Fraserwood Drive, Vaughan, Ontario
L4J 9C4 (CA).

Published:
— with international search report (Art. 21(3))

[Continued on next page]

(54) Title: ISOLATING APPARATUS FOR ELECTRIC POWER LINES AND METHODS FOR FORMING AND USING THE SAME

(57) Abstract: An isolating apparatus for an electric power line includes an elongate insulator having opposed insulator ends and a pair of electrically conductive end members each secured to a respective one of the insulator ends. At least one of the end members includes a mounting slot that receives its respective one of the insulator ends.

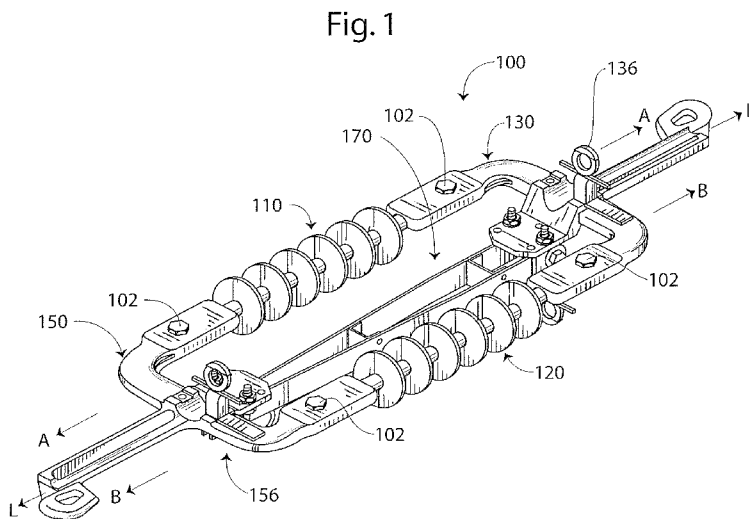

WO 2010/074945 A1

- *before the expiration of the time limit for amending the claims and to be republished in the event of receipt of amendments (Rule 48.2(h))*

ISOLATING APPARATUS FOR ELECTRIC POWER LINES AND METHODS FOR FORMING AND USING THE SAME

Field of the Invention

[001] The present invention relates to electrical power lines and, more particularly, to in-line isolation apparatus for electric power lines.

Background of the Invention

[002] In-line isolation devices such as in-line disconnect switches are commonly employed in electric power transmission lines where it is desired to permanently or selectively isolate a power line such as an overhead power line. Known isolation devices include a pair of end pieces (which may be referred to as dead ends) connected by an elongate insulator. The end pieces are each clamped to a power line. The power line is then cut between the end pieces so that the isolation device mechanically couples and electrically isolates the two ends of the power line. Examples of devices of this type are disclosed in Canadian Patent No. 2,092,741, U.S. Patent No. 5,581,051 to Hill, and U.S. Patent No. 5,942,723 to Laricchia.

Summary of the Invention

[003] According to embodiments of the present invention, an isolating apparatus for an electric power line includes an elongate insulator having opposed insulator ends and a pair of electrically conductive end members each secured to a respective one of the insulator ends. At least one of the end members includes a mounting slot that receives its respective one of the insulator ends.

[004] The isolating apparatus may further include a fastener that secures the respective one of the insulator ends in the mounting slot. In some embodiments, each of the end members includes a mounting slot that receives its respective one of the insulator ends, and the isolating apparatus further includes a respective fastener securing each insulator end

in its respective mounting slot. The isolating apparatus may further include a second elongate insulator having a body and opposed insulator ends, wherein: the end members are each secured to a respective one of the insulator ends of the second insulator; and each of the end members includes a second mounting slot that receives its respective one of the insulator ends of the second insulator, and the isolating apparatus further includes a respective fastener securing each insulator end of the second insulator in its respective mounting slot. In some embodiments, the end members and the first and second insulators are relatively arranged and configured such that the first and second insulators extend between the end members in spaced apart, coextensive, substantially parallel relation. According to some embodiments, the fastener is a bolt, and the respective one of the insulator ends is secured in the mounting slot by only the single bolt. In some embodiments, the insulator includes a connector lug on the respective one of the insulator ends and the connector lug is disposed in the mounting slot and the fastener engages the lug.

[005] According to some embodiments, the mounting slot is configured to alternatively receive each of a square insulator lug and a round insulator lug.

[006] In some embodiments, the at least one of the end members includes at least one stabilizer structure extending into the mounting slot and configured to engage the respective one of the insulator ends to limit rotation of the insulator about an axis transverse to a lengthwise axis of the insulator.

[007] According to some embodiments, the insulator defines a lengthwise axis extending between the insulator ends, and the mounting slot opens laterally with respect to the lengthwise axis to receive the respective one of the insulator ends.

[008] Each end member may include a coupling rod to secure the end member to the power line. The isolating apparatus can further include a wedge connector associated with each coupling rod to secure the end member to the power line.

[009] In some embodiments, the isolating apparatus further includes: a blade switch including an electrically conductive blade member electrically and pivotally connected to one of the end members such that the blade member is selectively movable between a closed position, wherein the blade member engages the other end member to provide electrical continuity between the end members, and an open position, wherein the blade member is out of contact with the other end member; and a lockout mechanism selectively operable to secure the blade member in the open position and, alternatively, to permit the blade member to be transitioned to the closed position.

[0010] According to embodiments of the present invention, an end member for forming an isolating apparatus for an electric power line, the isolating apparatus including a pair of the end members and an elongate insulator, includes an electrically conductive end member body having a mounting slot defined therein. The mounting slot is arranged and configured to receive an insulator end of the insulator.

[0011] The end member may include a fastener to secure the insulator end to the end member. According to some embodiments, the end member body has a second mounting slot defined therein, and the second mounting slot is arranged and configured to receive an insulator end of a second insulator to secure the insulator end of the second insulator to the end member such that the first and second insulators extend from the end member in spaced apart, coextensive, substantially parallel relation.

[0012] In some embodiments, the mounting slot is configured to alternatively receive each of a square insulator lug and a round insulator lug of the insulator.

[0013] According to some embodiments, the end member includes at least one stabilizer structure extending into the mounting slot and configured to engage the insulator end to limit rotation of the insulator about an axis transverse to a lengthwise axis of the insulator.

[0014] In some embodiments, the insulator defines a lengthwise axis extending between the insulator ends, and the mounting slot opens laterally with respect to the lengthwise axis to receive the respective one of the insulator ends.

[0015] The body can include a coupling rod to secure the end member to the power line.

[0016] According to method embodiments of the present invention, a method for providing an isolation apparatus for an electric power line includes: securing a pair of electrically conductive end members to respective opposed insulator ends of an elongate insulator. The step of securing includes inserting at least one of the insulator ends in a mounting slot of the respective end member.

[0017] The step of securing may include securing the insulator end in the mounting slot with a fastener. According to some embodiments, the fastener is a bolt, and the respective one of the insulator ends is secured in the mounting slot by only the single bolt. The step of securing may include inserting each of the insulator ends in a mounting slot of its respective end member, and securing each insulator end in the associated mounting slot with a respective fastener. The method may further include securing a second elongate insulator to

the end members by inserting each of the insulator ends in a respective mounting slot of its respective end member, and securing each insulator end in the associated mounting slot with a respective fastener, such that the first and second insulators extend between the end members in spaced apart, coextensive, substantially parallel relation.

[0018] The method can include, prior to the step of securing: providing a plurality of insulators of different lengths; and selecting the insulator from the plurality of insulators, wherein the length of the insulator corresponds to a desired voltage rating. In some embodiments, the method includes: providing a plurality of electrically conductive blade members of different lengths; selecting a blade member from the plurality of blade members, wherein the length of the blade member corresponds to the length of the selected insulator; and electrically and pivotally connecting the blade member to one of the end members such that the blade member is selectively movable between a closed position, wherein the blade member engages the other end member to provide electrical continuity between the end members, and an open position, wherein the blade member is out of contact with the other end member.

[0019] According to embodiments of the present invention, an isolating apparatus for an electric power line includes an elongate insulator, first and second electrically conductive end members, a blade switch, and a lockout mechanism. The elongate insulator has opposed insulator ends. The first and second electrically conductive end members are each secured to a respective one of the insulator ends. The blade switch includes an electrically conductive blade member electrically and pivotally connected to the first end member. The blade member is selectively movable between a closed position, wherein the blade member engages the second end member to provide electrical continuity between the first and second end members, and an open position, wherein the blade member is out of contact with the second end member. The lockout mechanism is selectively operable to secure the blade member in the open position and, alternatively, to permit the blade member to be transitioned to the closed position.

[0020] The locking mechanism may include a lock member that extends through the blade member when the blade member is in the open position.

[0021] In some embodiments, the locking mechanism includes a locking member that is rotatable between a locked position and an unlocked position. The isolating apparatus may include a spring member to retain the locking member in the locked position.

[0022] Further features, advantages and details of the present invention will be

appreciated by those of ordinary skill in the art from a reading of the figures and the detailed description of the preferred embodiments that follow, such description being merely illustrative of the present invention.

Brief Description of the Drawings

[0023] **Figure 1** is a top perspective view of an isolating apparatus according to embodiments of the present invention.

[0024] **Figure 2** is an exploded, top perspective view of the isolating apparatus of **Figure 1**.

[0025] **Figure 3** is a bottom perspective view of the isolating apparatus of **Figure 1**.

[0026] **Figure 4** is an exploded, bottom perspective view of the isolating apparatus of **Figure 1**.

[0027] **Figure 5** is an enlarged, fragmentary, perspective view of a mounting structure of the isolating apparatus of **Figure 1**.

[0028] **Figure 6** is an enlarged, fragmentary, cross-sectional view of the mounting structure of **Figure 5** taken along the line 6-6 of **Figure 5**.

[0029] **Figure 7** is an enlarged, top plan view of the mounting structure of **Figure 5** with a round lug mounted therein.

[0030] **Figure 8** is a top perspective view of the isolating apparatus of **Figure 1** mounted on the power line, wherein a blade switch mechanism of the isolating apparatus is in a closed position.

[0031] **Figure 9** is a fragmentary, side view of the isolating apparatus of **Figure 1** with the blade mechanism in the closed position.

[0032] **Figure 10** is an enlarged, fragmentary, perspective view of the isolating apparatus of **Figure 1** wherein a blade thereof is in an open position and a lockout mechanism thereof is in an unlocked position.

[0033] **Figure 11** is a top perspective view of the isolating apparatus of **Figure 1** mounted on the power line, wherein the blade switch mechanism is in a locked open position.

[0034] **Figure 12** is an enlarged, top plan view of the mounting structure of **Figure 5** with a square lug mounted therein.

Detailed Description of Embodiments of the Invention

[0035] The present invention now will be described more fully hereinafter with reference to the accompanying drawings, in which illustrative embodiments of the invention are shown. In the drawings, the relative sizes of regions or features may be exaggerated for clarity. This invention may, however, be embodied in many different forms and should not be construed as limited to the embodiments set forth herein; rather, these embodiments are provided so that this disclosure will be thorough and complete, and will fully convey the scope of the invention to those skilled in the art.

[0036] It will be understood that, although the terms first, second, etc. may be used herein to describe various elements, components, regions, layers and/or sections, these elements, components, regions, layers and/or sections should not be limited by these terms. These terms are only used to distinguish one element, component, region, layer or section from another region, layer or section. Thus, a first element, component, region, layer or section discussed below could be termed a second element, component, region, layer or section without departing from the teachings of the present invention.

[0037] Spatially relative terms, such as "beneath", "below", "lower", "above", "upper" and the like, may be used herein for ease of description to describe one element or feature's relationship to another element(s) or feature(s) as illustrated in the figures. It will be understood that the spatially relative terms are intended to encompass different orientations of the device in use or operation in addition to the orientation depicted in the figures. For example, if the device in the figures is turned over, elements described as "below" or "beneath" other elements or features would then be oriented "above" the other elements or features. Thus, the exemplary term "below" can encompass both an orientation of above and below. The device may be otherwise oriented (rotated 90° or at other orientations) and the spatially relative descriptors used herein interpreted accordingly.

[0038] As used herein, the singular forms "a", "an" and "the" are intended to include the plural forms as well, unless expressly stated otherwise. It will be further understood that the terms "includes," "comprises," "including" and/or "comprising," when used in this specification, specify the presence of stated features, integers, steps, operations, elements, and/or components, but do not preclude the presence or addition of one or more other features, integers, steps, operations, elements, components, and/or groups thereof. It will be understood that when an element is referred to as being "connected" or "coupled" to another element, it can be directly connected or coupled to the other element or intervening elements

may be present. As used herein, the term "and/or" includes any and all combinations of one or more of the associated listed items.

[0039] Unless otherwise defined, all terms (including technical and scientific terms) used herein have the same meaning as commonly understood by one of ordinary skill in the art to which this invention belongs. It will be further understood that terms, such as those defined in commonly used dictionaries, should be interpreted as having a meaning that is consistent with their meaning in the context of this specification and the relevant art and will not be interpreted in an idealized or overly formal sense unless expressly so defined herein.

[0040] With reference to **Figures 1-12**, an in-line isolating apparatus **100** according to embodiments of the present invention is shown therein. The isolating apparatus **100** may be used with a pair of wedge connectors **20** (or other suitable connectors) to form an in-line isolation assembly **5** (**Figures 8-11**) wherein a pair of power lines, cable segments or cables **12, 14** are mechanically coupled and electrically isolated by the isolating apparatus **100**. The cables **12, 14** may be initially provided as an integral (mechanically and electrically continuous) power line **10** that is severed into the cables **12, 14** as part of the procedure for forming the in-line isolation assembly **5**. The isolating apparatus **100** may be referred to as an in-line disconnect device or an in-line switch because it further incorporates a switch mechanism as discussed herein.

[0041] The isolating apparatus **100** includes a pair of end members **130, 150** joined by a pair of insulators **110, 120**. The isolating apparatus **100** further includes a blade switch mechanism **170** and a plurality of connecting bolts **102**, nuts **104**, and washers **106**. Some or all of the fastening components **102, 104, 106** may be replaced with other types of fastening components such as rivets. The isolating apparatus **100** has a lengthwise axis **L-L** (**Figure 1**).

[0042] The insulator **110** is elongate and has opposed ends **110A, 110B** and a lengthwise insulator axis **A-A** (**Figure 1**). The insulator **110** includes an electrically insulating body **112** and connector lugs **116** secured to either end of the body **112** (*e.g.*, by crimping). The insulating body **112** may be of any suitable construction. According to some embodiments, the insulating body **112** includes a rigid (*e.g.*, fiberglass) rod surrounded by a rubberized cover. Radially outwardly extending sheds **114** may be provided, which may form a part of the rubberized cover. According to some embodiments, the insulating body **112** is

formed of any suitable material, such as aluminum. A fastening hole 118 extends laterally through each lug 116.

[0043] The insulator 120 may be formed in the same manner as described above for the insulator 110 and has a lengthwise axis B-B, opposed ends 120A, 120B, an insulating body 122 (with sheds 124), and lugs 126 (with fastening holes 128).

[0044] The end member 130 (which may also be referred to as a “dead end”) includes a body or yoke member 132 and a coupling rod 134, which may be integrally formed with the yoke member 132. A lengthwise cable groove 134A is defined in the coupling rod 134, and a pulling eye 134B is provided on an outer end of the rod 134.

[0045] The end member 130 further includes a retainer mechanism 136. The retainer mechanism 136 includes a keeper bar 136A rotatable between an open position (as shown in Figure 1) and a closed position (as shown in Figure 8). In the open position, the keeper bar 136A permits a cable to be laid laterally into the groove 134A and, in the closed position, the keeper bar 136A can prevent a cable from being laterally removed from the groove 134A. According to some embodiments, the retainer mechanism 136 is constructed and operable as disclosed in U.S. Patent No. 5,942,723 to Laricchia, the disclosure of which is incorporated herein by reference.

[0046] Laterally spaced apart mounting structures 140L, 140R are located on the inner end of the yoke member 132, and may be integrally formed (*e.g.*, by casting) therewith. A mounting pocket or slot 142 is defined in each mounting structure 140L, 140R. Each mounting slot 142 has a lengthwise axis C-C substantially parallel to the axis A-A. Each mounting slot 142 has an axial entrance opening 144A and a lateral opening 144B. A fastener hole 148 extends laterally through each mounting structure 140L, 140R to the mounting slot 142 thereof. A stabilizer structure 146 is located in each mounting slot 140L, 140R and may take the form of a U-shaped ring as shown. Each stabilizer structure 146 defines a slot 146A. Each stabilizer structure 146 may be integrally formed with the corresponding mounting structure 140L, 140R (*e.g.*, by casting). Each stabilizer structure 146 defines an outer subslot or lug cavity 144C in its mounting slot 142.

[0047] According to some embodiments, each lug cavity 144C has a width E (Figure 7) in the range of from about 2 to 3 inches. According to some embodiments, the clearance between each lug 116 and the adjacent side walls defining the lug cavity 144C is in the range of from about 0.005 to 0.03 inch. According to some embodiments, each lug cavity 144C has

a depth **F** (**Figure 6**) in the range of from about 0.5 to 1 inch. According to some embodiments, the depth **F** is greater than the thickness **N** (**Figure 2**) of each lug **116**. According to some embodiments, each mounting slot **142** has an inner length **G1** (*i.e.*, from the inner side of the axial entrance opening **144A** to the lug cavity **144C**; **Figure 6**) in the range of from about 1 to 1.5 inches. According to some embodiments, each lug cavity **144C** has a length **G2** (*i.e.*, from the outer side of the stabilizer structure **146** to the outer end of the lug cavity **144C**; **Figure 6**) in the range of from about 2 to 3 inches. According to some embodiments, the width **H** (**Figure 7**) of each axial entrance opening **144A** is in the range of from about 1 to 2 inches of the insulator **110** or **120** to be received thereby. According to some embodiments, the width **I** (**Figure 7**) of each stabilizer slot **146A** is in the range of from about 1 to 2 inches of the insulator **110** or **120** to be received thereby. According to some embodiments, the entrance opening **144A** and the stabilizer slot **146A** each provide a clearance in the range of from about 0.005 to 0.03 inch about the portion of the insulator **110**, **120** received therein.

[0048] The end member **130** may be formed of any suitable material. According to some embodiments, the end member **130** is formed of an electrically conductive metal. According to some embodiments, the end member **130** is formed of aluminum. According to some embodiments, the end member **130** is unitarily cast.

[0049] The end member **150** may be constructed in the same manner as the end member **130**. According to some embodiments and as shown, the retainer mechanism **136**, **156** of the end members **130**, **150** is configured such that the keeper bars **136A**, **156A** thereof open to the same side (as shown in **Figure 1**). The end member **150** has mounting structures **160L**, **160R** corresponding to the mounting structures **140L**, **140R** and having respective mounting slots **162**.

[0050] The blade switch mechanism **170** includes an electrically conductive blade member **172**, a pivot bracket **174**, a receiver bracket **176**, and a latch mechanism **178**. The receiver bracket **176** is mounted on the end member **150** and the pivot bracket is mounted on the end member **130**. The blade member **172** includes a pair of blade plates **179** defining an opening **181** therebetween. The blade member **172** has a pivot end **172B** pivotably coupled to the pivot bracket **174** (by a bolts **102** extending through pivot holes **172A**) for rotation about a transverse pivot axis **P-P** (**Figure 3**) between an open position as shown in **Figure 11** and a closed position as shown in **Figures 3, 8 and 9**. In the closed position, a contact end

172A of the blade member 172 is received in and contacts the receiver bracket 176 to provide electrical continuity between the end members 130 and 150 (more particularly, from the coupling rod 134 to the coupling rod 154). In the open position, the contact end 172A is spaced apart from the receiver bracket 176 and the end members 130, 150, being coupled only by the insulators 110, 120, are electrically isolated from one another.

[0051] A latch mechanism 178 may be provided to secure the blade member 172 in the closed position. The latch mechanism 178 includes a latch member 178A and a latch handle 178B for selectively disengaging and/or engaging the latch member 178A with the receiver bracket 176, for example.

[0052] The various components 172, 174, 176, 178A of the latch mechanism 170 can be formed of any suitable electrically conductive materials, such as copper, steel or aluminum.

[0053] The isolating apparatus 100 further includes a lockout mechanism 180. The lockout mechanism 180 includes a lockout member 182, a seat structure 184, a spring 186, and an anchor bolt 188. The lockout member 182 includes a shaft 182A, a pair of opposed lateral extensions or arms 182B extending laterally from the shaft 182A, a pull ring 182C, a threaded mount bore 182D, and a base 182E. The bolt 188 extends through a hole 187 in the end member 130 and is threadedly received in the bore 182D. The spring 186 is mounted on the shank of the bolt 188 and is seated in the hole 187. The base 182E of the lockout member 182 is seated in the seat structure 184 on the end member 130. The seat structure 184 includes risers or prongs 184A (Figure 10) defining a longitudinal slot 184B and a transverse slot 184C. The base 182E can seat alternatively in the slot 184B or the slot 184C.

[0054] In use (as discussed in more detail below), the lockout member 182 can be pulled outwardly along a pull axis J-J against the force of the spring 186 and rotated about the axis J-J to reorient the extension arms 182B. Full removal of the lockout member 182 from the end member 130 is prevented by the head 188A of the bolt 188 and the spring 186.

[0055] The lockout member 182 may be formed of any suitable material, such as aluminum, for example.

[0056] Each wedge connector 20 includes a C-shaped clamp 22 and a wedge member 24. Suitable connectors 20 include AMPACT™ tap connectors available from Tyco Electronics Corporation. According to some embodiments, the wedge connectors 20 may be constructed and installed as disclosed in U.S. Patent No. 5,942,723 to Laricchia and/or U.S.

Published Patent No. 2007/0240301 (Johnston et al.), for example, the disclosures of which are incorporated herein by reference.

[0057] The isolating apparatus **100** may be assembled in the following manner. The lug **116** on the insulator end **110A** is mounted in the mounting slot **142** of the mounting structure **140L**, the lug **116** on the insulator end **110B** is mounted in the mounting slot **162** of the mounting structure **160L**, the lug **126** on the insulator end **120A** is mounted in the mounting slot **142** of the mounting structure **140R**, and the lug **126** on the insulator end **120B** is mounted in the mounting slot **162** of the mounting structure **160R**. The lugs **116**, **126** are each secured in their respective mounting slots **142**, **162** by a respective set of bolt **102**, nut **104** and washers **106**. More particularly and referring to the coupling of the lug **116** on the insulator end **110A** to the mounting structure **140L**, which is exemplary of the couplings of the other lugs **116**, the lug **116** is laterally inserted or laid into the mounting slot **142** through the lateral opening **144B** as indicated by the directional arrow **Q** in **Figure 6**. As shown in **Figure 7**, the lug **116** is seated in the mounting slot **142** such that lug **116** is positioned in the lug cavity **144C** and the remainder of the insulator **110** (e.g., the body **112**) extends axially out of the mounting slot **132** through the stabilizer structure slot **146A** and the axial entrance opening **144A**. The bolt **102** is inserted through the hole **148** and the lug hole **118** and secured by the nut **104**. The bolt **102** and nut **104** thus prevent the lug **116** from being displaced laterally or axially from the mounting slot **142**. The stabilizer structure **146** and the entrance opening **144A** inhibit or prevent rotation of the lug **116** about the bolt **102**.

[0058] The brackets **174** and **176** are secured to the end members **130** and **150**, respectively, by corresponding bolts **105** and nuts **106**. The blade member **172** is pivotably connected to the bracket **174** by bolts **107** and nuts **108**. The retainer mechanisms **136** can be secured to the respective end members **130**, **150** as disclosed in U.S. Patent No. 5,942,723 to Laricchia, for example. The lockout member **182** is secured to the end member **130** by the bolt **188** and the spring **186**.

[0059] Once assembled, the insulators **110**, **120** extend between the end members **130**, **150** in spaced apart, coextensive, substantially parallel relation. The mounting slots **142**, **162** open laterally with respect to the lengthwise axes **A-A**, **B-B** of the respective installed insulators **110**, **120**.

[0060] Once the isolating apparatus **100** has been assembled, it may be installed on a power line **10** in a known manner, for example. According to some methods, the keeper bars

136A are placed in their open positions. The isolating apparatus **100** is laid on the power line **10** with the grooves **134A** facing downwardly and such that the power line **10** extends through the grooves **134A** and between the end members **130**, **150**. The keeper bars **136A** are then moved (*e.g.*, using hotsticks) to their closed positions so that they capture the power line **10** in the grooves **134A**. The isolating apparatus **100** is then rotated 180 degrees about the power line **10** to the upright position as shown in **Figure 8**.

[0061] The wedge clamps **20** are then installed about the power line **10** and each coupling rod **134** as shown in **Figure 8**. The wedge clamps **20** may be installed using a powder-actuated impact tool, for example.

[0062] The power line **10** can then be cut between the end members **130**, **150** to divide the power line **10** into two separate cable segments or cables **12**, **14**. The cables **12** and **14** are securely coupled to the end member **130** and the end member **150**, respectively, so that the tension from the power line **10** is now applied to the isolating apparatus **100**. The cut ends **12A**, **14A** can then be bent away from one another as shown in **Figure 8** to electrically isolate the cables **12**, **14** from one another and/or a section of the power line **10** between the end members **130**, **150** can be cut out and removed.

[0063] When it is desired to electrically connect the cables **12**, **14**, the blade member **172** can be pivoted into the closed position as shown in **Figures 8** and **9** to electrically connect the end members **130**, **150**. The blade member **172** can be securely and releasably retained in the closed position by the latch mechanism **178**.

[0064] When it is desired to electrically isolate or disconnect the cables **12**, **14**, the blade member **172** can be pivoted into its open position as shown in **Figures 10** and **11**. The lockout mechanism **180** can be used to securely and releasably retain the blade member **172** in its open position. More particularly, the lockout member **182** is rotated to a position wherein the extension arms **182B** will pass through the opening **181** in the blade member **172** (which may be referred to as an “unlocked position” of the lockout member **182**) as shown in **Figure 10**. The lockout member **182** can be secured in the unlocked position by seating the base **182E** in the longitudinal slot **184B**. The spring **186** retains the base **182E** in the slot **184B**. When the blade member **172** is swung into the open position, the lockout member **182** is received through or proximate the opening **181**. The lockout member **182** is then pulled outwardly along the axis **J-J** against the bias of the spring **186** until the shaft **182A** extends through the opening **181** and the extension arms **182B** clear the blade member **172**. The

lockout member **182** is then rotated about 90 degrees and released so that the extension arms **182B** overlap or intersect the swing path of the blade plates **179** and the lockout member **182** captures the blade member **172** (which may be referred to as a “locked position” of the lockout member **182**) as shown in **Figure 11**. The lockout member can be secured in the locked position by seating the base **182E** in the transverse slot **184C**. The spring **186** retains the base **182E** in the slot **184C**.

[0065] According to some embodiments, in the locked position the spring **186** continues to apply a tension load on the lockout member **182** to bias the extension arms **182A** against the fully open blade member **172**. In this configuration, it is necessary to pull the lockout member **182** outwardly against the force of the spring **186** to enable the extension arms **182B** to be rotated and free the blade member **172**. The blade member **172** is thereby prevented from returning to the closed position unless and until an operator deliberately returns the lockout member **182** to the unlocked position, whereupon the blade member **172** can be pivoted to the closed position. More particularly, the operator can pull the lockout member **182** outwardly and rotate it about 90 degrees until the extension arms **182A** are substantially clear of the blade plates **179**.

[0066] While the insulators **110**, **120** as described above have round profile lugs **116**, the end members **130**, **150** are further adapted to form an isolating apparatus **100** with insulators having rectangular (*e.g.*, square) lugs. With reference to **Figure 12**, an insulator **210** having a square profile lug **216** is shown therein. The square lug **216** can be installed and secured by a bolt **102** and nut **104** in the mounting slot **142** of the mounting portion **140L** in the same manner as described above with regard to the round lug **116**. The mounting slots **142**, **162** of the other mounting portions **140R**, **160L**, **160R** are likewise adapted and configured to effectively receive and couple with square lugs **216**. Thus, the isolating apparatus **100** can be formed using the same two end members **130**, **150** and insulators having round lugs, square lugs, or any combination thereof.

[0067] The isolating apparatus **100** can provide a number of advantages over known power line isolating devices. The isolating apparatus **100** incorporates the end members **130**, **150**, the insulators **110**, **120**, and the blade member **172** as modular components with flexible and noncomplex coupling mechanisms. The isolating apparatus **100** can be assembled quickly and efficiently without requiring specialized tools or skills. The isolating apparatus **100** can be assembled by an installer in the field. The isolating apparatus **100** can be quickly

maintained and repaired, such as by replacing one or more damaged components (*e.g.*, an insulator **110**, **120** and/or the blade member **172**). The isolating apparatus **100** can employ readily available and standard hardware (*e.g.*, the bolts **102**, nuts **104** and washers **106**) and insulators **110**, **120** rather than requiring the manufacture and inventorying of certain specialized components.

[0068] The use of a bolt **102** (and, according to some embodiments, a single bolt **102**) to secure each lug **116**, **126** to couple the insulators **110**, **120** provides an effective mechanism for securing the insulators **110**, **120** to the end members **130**, **150** that can be quickly and simply executed. The single bolt installation also permits the use of industry standard lugged insulators, thereby eliminating the need for expensive crimping of insulator fittings to the yokes **132**, **152**.

[0069] The stabilizer structures **146**, **166** in each mounting slot **142**, **162** extend along either side of the received insulator **110**, **120** to securely hold the ends of the insulators **110**, **120** in the mounting slots **142**, **162**. The stabilizer structures **146** thereby limit or prevent rotation of each lug **116**, **126** about the axis of the bolt **102** by which the lug **116**, **126** is secured (*i.e.*, the axis **R-R** transverse to the lengthwise axis **A-A**, **B-B** of the insulator **110**, **120** (**Figure 6**)) to maintain the rigidity of the isolating apparatus **100**.

[0070] Each mounting slot **142**, **162** is configured to serve as a universal adaptor to accept various standard insulator lug configurations. In particular, the mounting slots **142**, **162** are each configured to receive either of the industry standard round lugs **116** and the industry standard rectangular lugs **216**. Mounting slots according to embodiments of the present invention may be configured to operatively accept other shapes, as well.

[0071] The modular design of the isolating apparatus **100** also permits the isolating apparatus **100** to be selectively configured or customized as desired for the intended application. According to some methods of the present invention, a plurality of insulators **110**, **120** and/or blade members **172** of different lengths or other attributes are provided and an assembler selects from the plurality of insulators and/or blade members those appropriate to provide the intended attributes of the isolating apparatus **100**. For example, a plurality of insulators **110**, **120** of different lengths and blade members **172** of corresponding lengths may be provided each corresponding to a different voltage rating (*e.g.*, longer insulators providing a higher voltage rating). In assembling the isolating apparatus **100**, the assembler selects the insulators **110**, **120** and blade member **172** from the plurality of insulators having the length

corresponding to the desired voltage rating. According to some embodiments, the assembler is a field installer. According to some embodiments, the end members **130**, **150** are supplied as a system or kit with a plurality of insulators of different lengths and, in some embodiments, also with a plurality of blade members of different lengths matched to the lengths of the insulators. According to some embodiments, the end members **130**, **150** are provided as a system or kit with a plurality of blade members of different lengths matched to industry standard lengths of insulators (though the insulators themselves may not be provided as part of the kit). Systems as described may reduce the inventory of components needed by the installer and/or may permit the installer to use industry standard insulators on hand. According to some embodiments, the plurality of insulators provided can be configured to provide an isolating apparatus **100** having a voltage rating across the range of 15 to 69 kV.

[0072] The lockout mechanism **180** can provide positive locking of the blade member **172** in its fully open position to prevent accidental blade rotational movement that would close the isolating apparatus **100** and thereby the electrical loop of the power line **10**. In this manner, the lockout mechanism **180** can provide improved operational safety without unduly increasing the cost or operational requirements of the isolating apparatus **100**.

[0073] According to further embodiments of the present invention, the isolating apparatus **100** can be provided without the blade mechanism **170**, without the lockout mechanism **180**, or without the blade mechanism **170** and the lockout mechanism **180**.

[0074] According to some embodiments, the lockout mechanism **180** may be provided on isolating apparatus of other designs or configurations (*e.g.*, not having mounting slots and/or lugged insulators as disclosed herein).

[0075] While the insulating apparatus **100** has been described herein installed on segments **12**, **14** of a power line **10**, according to some embodiments, the insulating apparatus **100** may be installed on each of a cable and a dead end post, for example.

[0076] The foregoing is illustrative of the present invention and is not to be construed as limiting thereof. Although a few exemplary embodiments of this invention have been described, those skilled in the art will readily appreciate that many modifications are possible in the exemplary embodiments without materially departing from the novel teachings and advantages of this invention. Accordingly, all such modifications are intended to be included within the scope of this invention. Therefore, it is to be understood that the foregoing is illustrative of the present invention and is not to be construed as limited to the specific

embodiments disclosed, and that modifications to the disclosed embodiments, as well as other embodiments, are intended to be included within the scope of the invention.

That which is claimed is:

1. An isolating apparatus for an electric power line, the isolating device comprising:
 - an elongate insulator having opposed insulator ends; and
 - a pair of electrically conductive end members each secured to a respective one of the insulator ends;
 - wherein at least one of the end members includes a mounting slot that receives its respective one of the insulator ends.
2. The isolating apparatus of Claim 1 further including a fastener that secures the respective one of the insulator ends in the mounting slot.
3. The isolating apparatus of Claim 2 wherein each of the end members includes a mounting slot that receives its respective one of the insulator ends, and the isolating apparatus further includes a respective fastener securing each insulator end in its respective mounting slot.
4. The isolating apparatus of Claim 3 further including a second elongate insulator having a body and opposed insulator ends, wherein:
 - the end members are each secured to a respective one of the insulator ends of the second insulator; and
 - each of the end members includes a second mounting slot that receives its respective one of the insulator ends of the second insulator, and the isolating apparatus further includes a respective fastener securing each insulator end of the second insulator in its respective mounting slot.
5. The isolating apparatus of Claim 4 wherein the end members and the first and second insulators are relatively arranged and configured such that the first and second insulators extend between the end members in spaced apart, coextensive, substantially parallel relation.
6. The isolating apparatus of Claim 2 wherein the fastener is a bolt, and the

respective one of the insulator ends is secured in the mounting slot by only the single bolt.

7. The isolating apparatus of Claim 2 wherein the insulator includes a connector lug on the respective one of the insulator ends, the connector lug is disposed in the mounting slot, and the fastener engages the lug.

8. The isolating apparatus of Claim 1 wherein the mounting slot is configured to alternatively receive each of a square insulator lug and a round insulator lug.

9. The isolating apparatus of Claim 1 wherein the at least one of the end members includes at least one stabilizer structure extending into the mounting slot and is configured to engage the respective one of the insulator ends to limit rotation of the insulator about an axis transverse to a lengthwise axis of the insulator.

10. The isolating apparatus of Claim 1 wherein the insulator defines a lengthwise axis extending between the insulator ends, and the mounting slot opens laterally with respect to the lengthwise axis to receive the respective one of the insulator ends.

11. The isolating apparatus of Claim 1 wherein each end member includes a coupling rod to secure the end member to the power line.

12. The isolating apparatus of Claim 11 further including a wedge connector associated with each coupling rod to secure the end member to the power line.

13. The isolating apparatus of Claim 1 further including:
a blade switch including an electrically conductive blade member electrically and pivotally connected to one of the end members such that the blade member is selectively movable between a closed position, wherein the blade member engages the other end member to provide electrical continuity between the end members, and an open position, wherein the blade member is out of contact with the other end member;
and

a lockout mechanism selectively operable to secure the blade member in the open position and, alternatively, to permit the blade member to be transitioned to the

closed position.

14. An end member for forming an isolating apparatus for an electric power line, the isolating apparatus including a pair of the end members and an elongate insulator, the end member comprising:

an electrically conductive end member body having a mounting slot defined therein;

wherein the mounting slot is arranged and configured to receive an insulator end of the insulator.

15. The end member of Claim 14 including a fastener to secure the insulator end to the end member.

16. The end member of Claim 15 wherein:

the end member body has a second mounting slot defined therein; and

the second mounting slot is arranged and configured to receive an insulator end of a second insulator to secure the insulator end of the second insulator to the end member such that the first and second insulators extend from the end member in spaced apart, coextensive, substantially parallel relation.

17. The end member of Claim 14 wherein the mounting slot is configured to alternatively receive each of a square insulator lug and a round insulator lug of the insulator.

18. The end member of Claim 14 wherein the end member includes at least one stabilizer structure extending into the mounting slot and configured to engage the insulator end to limit rotation of the insulator about an axis transverse to a lengthwise axis of the insulator.

19. The end member of Claim 14 wherein the insulator defines a lengthwise axis extending between the insulator ends, and the mounting slot opens laterally with respect to the lengthwise axis to receive the respective one of the insulator ends.

20. The end member of Claim 14 wherein the body includes a coupling rod to

secure the end member to the power line.

21. A method for providing an isolation apparatus for an electric power line, the method comprising:

securing a pair of electrically conductive end members to respective opposed insulator ends of an elongate insulator;

wherein the step of securing includes inserting at least one of the insulator ends in a mounting slot of the respective end member.

22. The method of Claim 21 wherein the step of securing includes securing the insulator end in the mounting slot with a fastener.

23. The method of Claim 22 wherein the fastener is a bolt, and the respective one of the insulator ends is secured in the mounting slot by only the single bolt.

24. The method of Claim 22 wherein the step of securing includes inserting each of the insulator ends in a mounting slot of its respective end member, and securing each insulator end in the associated mounting slot with a respective fastener.

25. The method of Claim 22 further including securing a second elongate insulator to the end members by inserting each of the insulator ends in a respective mounting slot of its respective end member, and securing each insulator end in the associated mounting slot with a respective fastener, such that the first and second insulators extend between the end members in spaced apart, coextensive, substantially parallel relation.

26. The method of Claim 21 including, prior to the step of securing:
providing a plurality of insulators of different lengths; and
selecting the insulator from the plurality of insulators, wherein the length of the insulator corresponds to a desired voltage rating.

27. The method of Claim 26 including:
providing a plurality of electrically conductive blade members of different lengths;

selecting a blade member from the plurality of blade members, wherein the length of the blade member corresponds to the length of the selected insulator; and electrically and pivotally connecting the blade member to one of the end members such that the blade member is selectively movable between a closed position, wherein the blade member engages the other end member to provide electrical continuity between the end members, and an open position, wherein the blade member is out of contact with the other end member.

28. An isolating apparatus for an electric power line, the isolating device comprising:

an elongate insulator having opposed insulator ends;

first and second electrically conductive end members each secured to a respective one of the insulator ends;

a blade switch including an electrically conductive blade member electrically and pivotally connected to the first end member, wherein the blade member is selectively movable between a closed position, wherein the blade member engages the second end member to provide electrical continuity between the first and second end members, and an open position, wherein the blade member is out of contact with the second end member; and

a lockout mechanism selectively operable to secure the blade member in the open position and, alternatively, to permit the blade member to be transitioned to the closed position.

29. The isolating apparatus of Claim 28 wherein the locking mechanism includes a lock member that extends through the blade member when the blade member is in the open position.

30. The isolating apparatus of Claim 28 wherein the locking mechanism includes a locking member that is rotatable between a locked position and an unlocked position.

31. The isolating apparatus of Claim 30 including a spring member to retain the locking member in the locked position.

Fig. 1

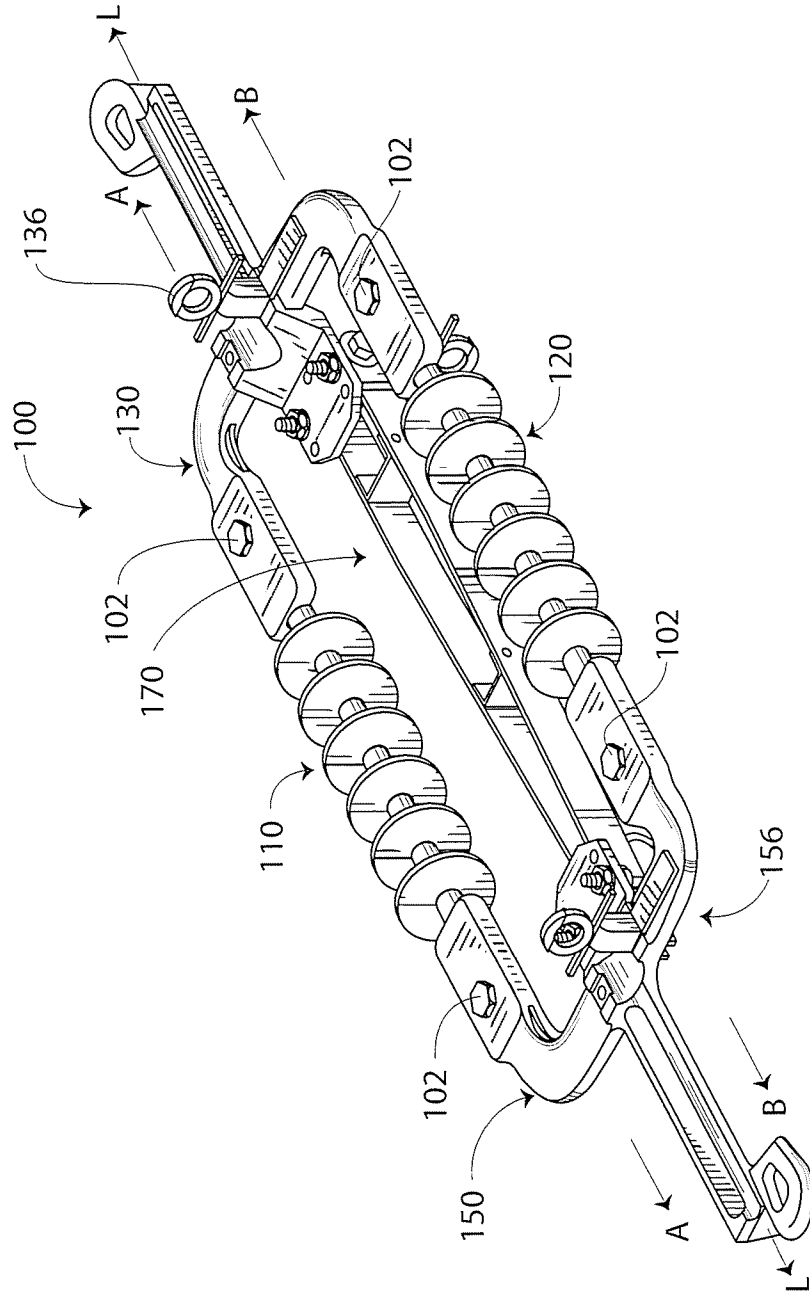

Fig. 2

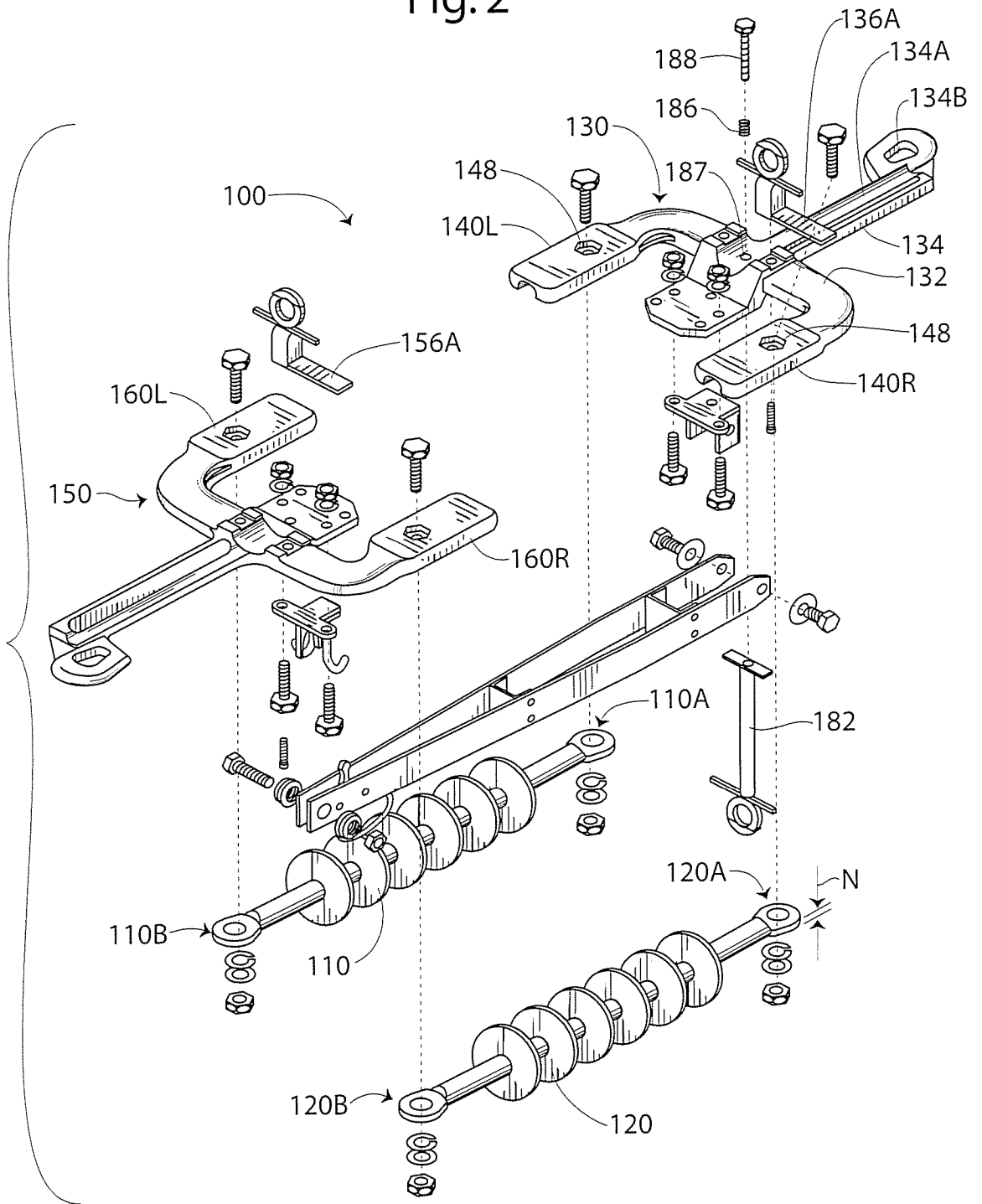

Fig. 3

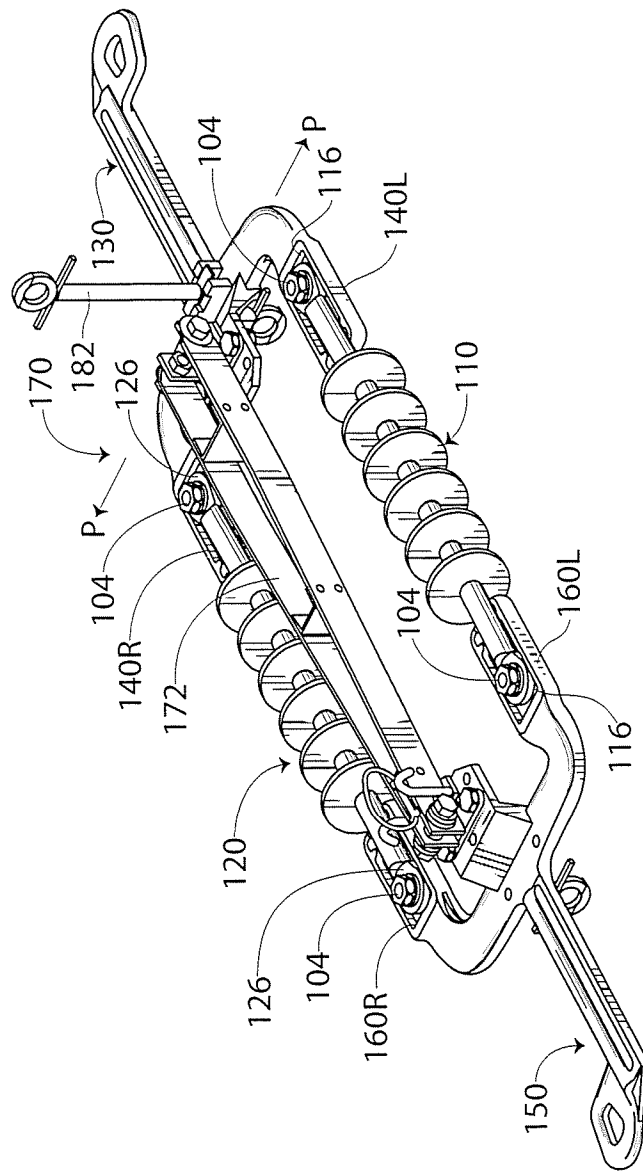

Fig. 4

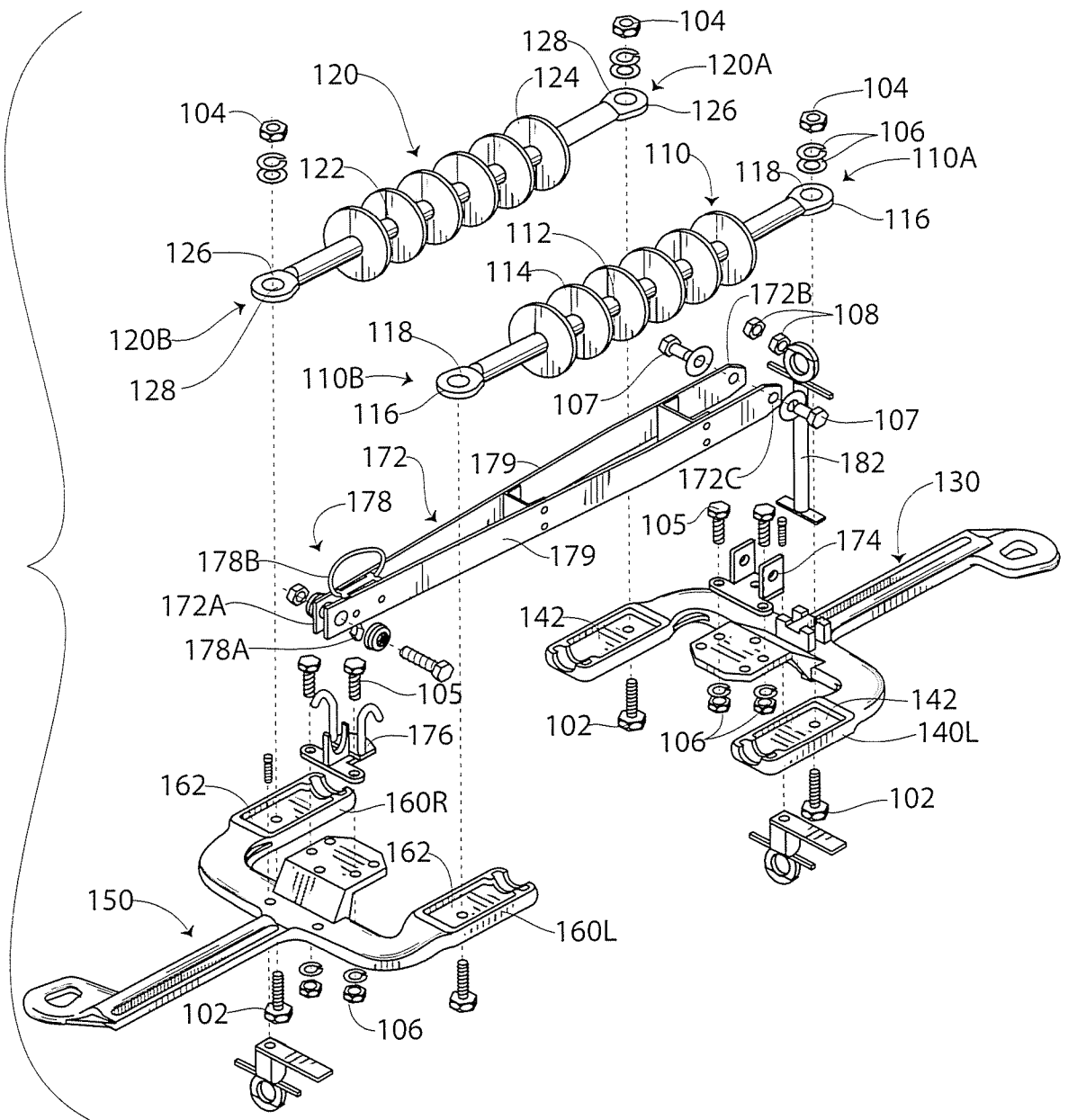

Fig. 5

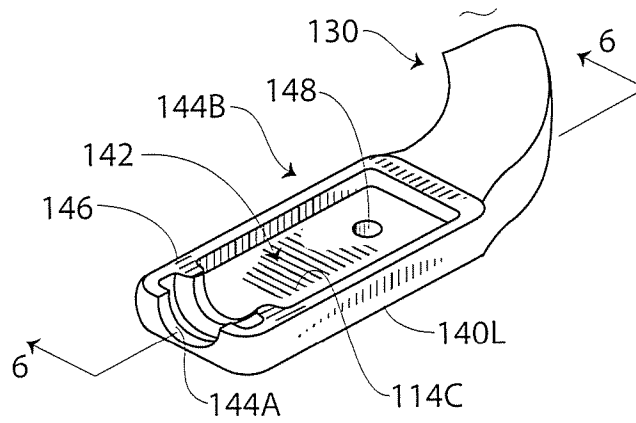

Fig. 6

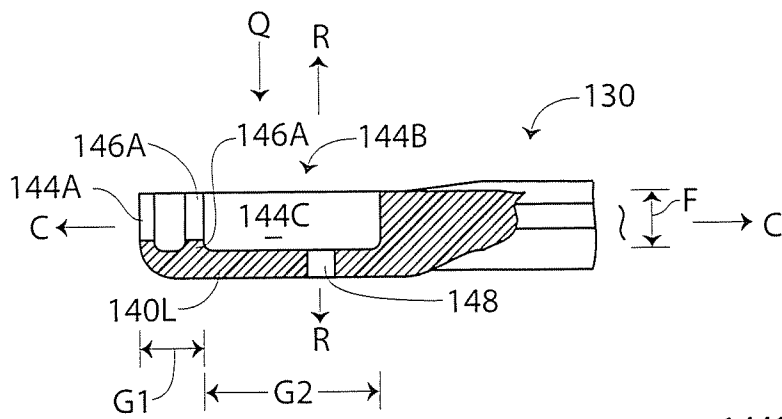

Fig. 7

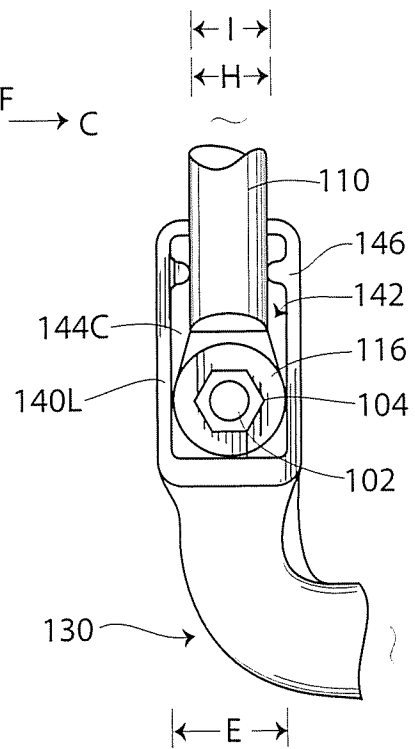

Fig. 8

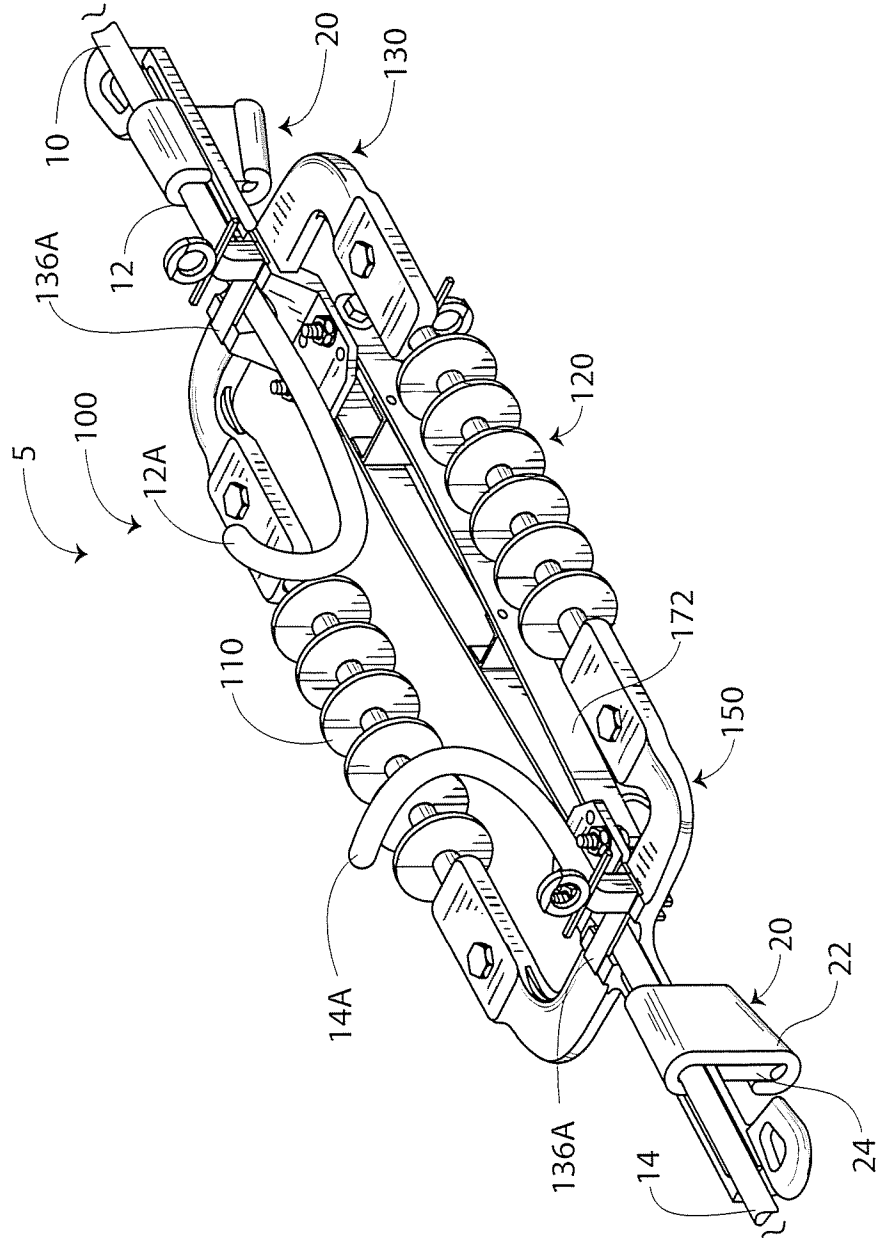

Fig. 9

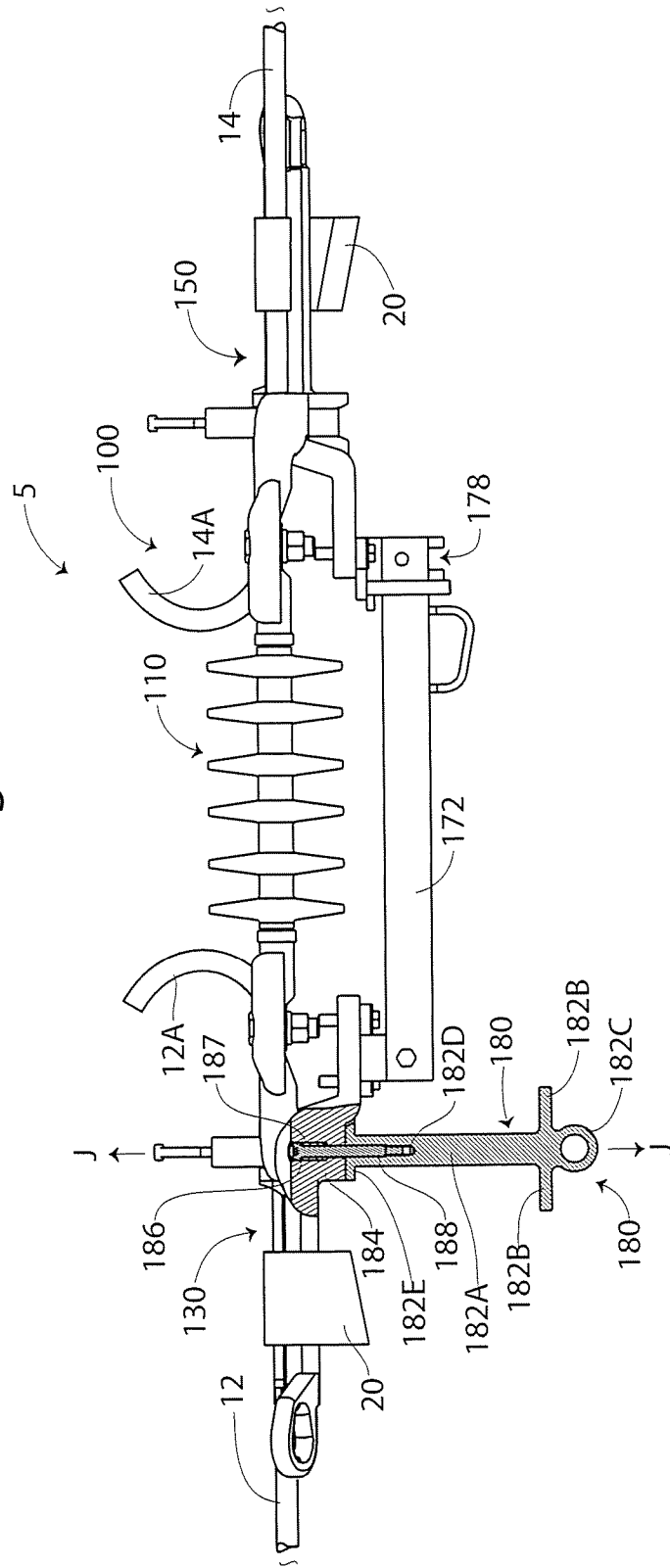

Fig. 10

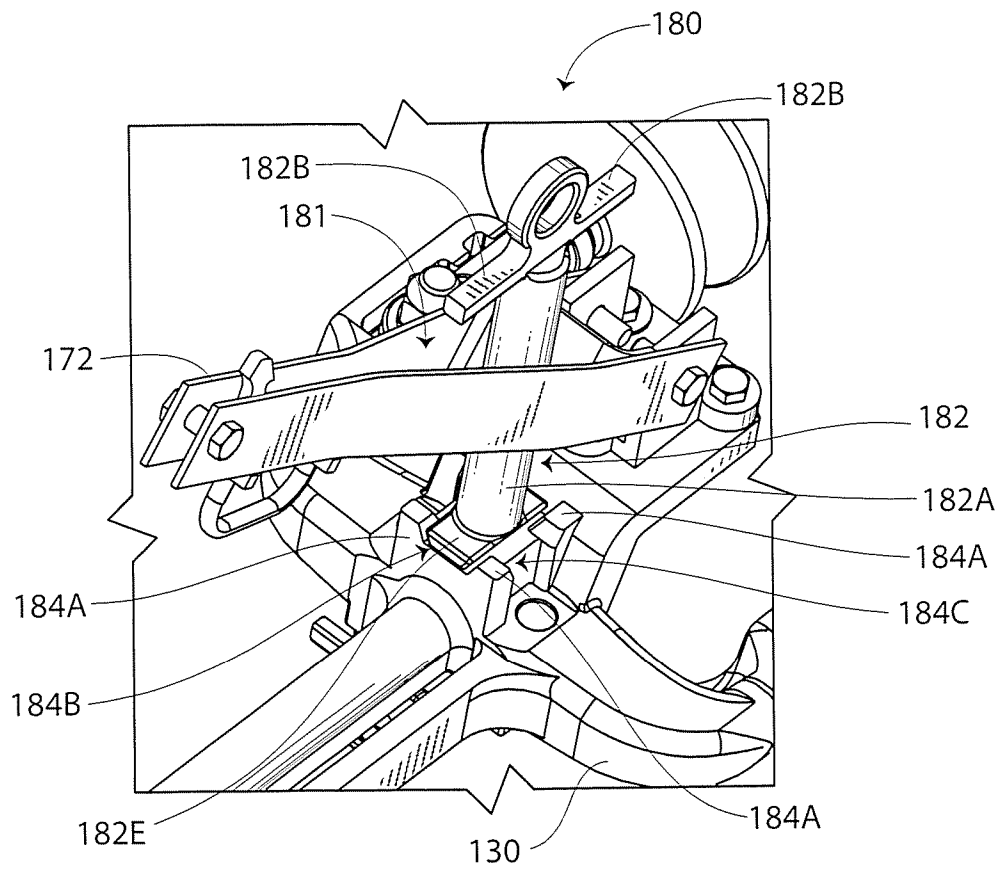

Fig. 11

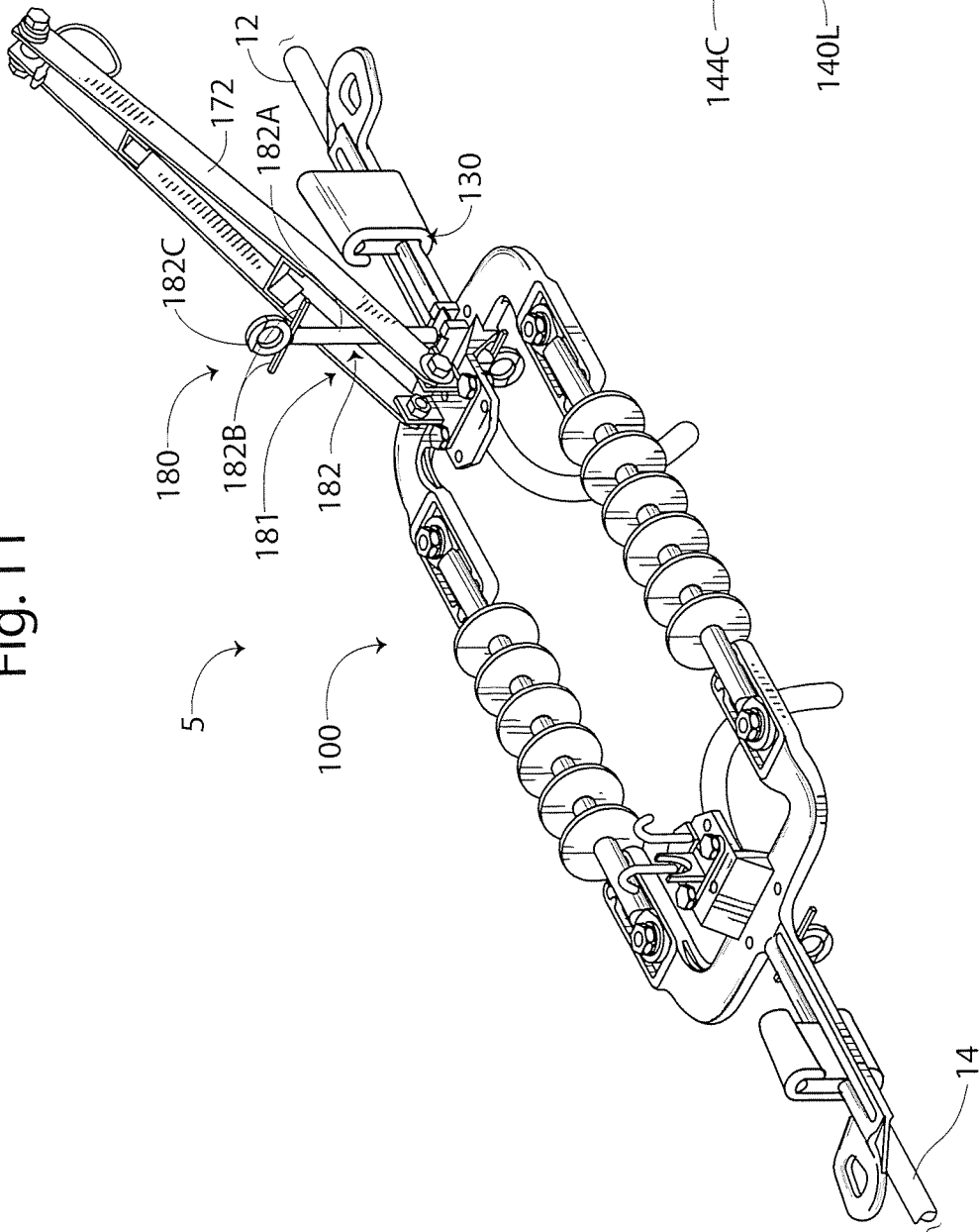
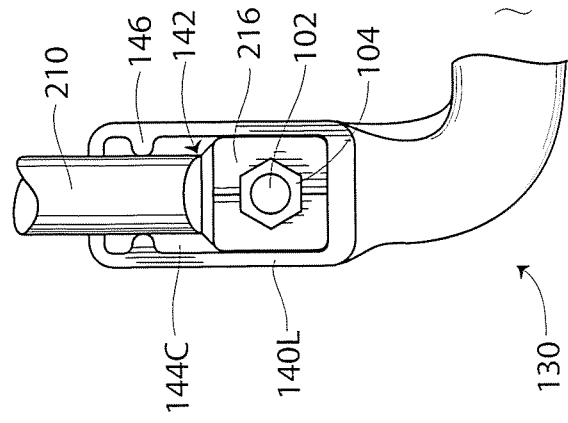

Fig. 12



INTERNATIONAL SEARCH REPORT

International application No
PCT/US2009/067049

A. CLASSIFICATION OF SUBJECT MATTER
INV. H01H31/00 H02G7/04

According to International Patent Classification (IPC) or to both national classification and IPC

B. FIELDS SEARCHED

Minimum documentation searched (classification system followed by classification symbols)
H01H H02G

Documentation searched other than minimum documentation to the extent that such documents are included in the fields searched

Electronic data base consulted during the international search (name of data base and, where practical, search terms used)

EPO-Internal

C. DOCUMENTS CONSIDERED TO BE RELEVANT

Category*	Citation of document, with indication, where appropriate, of the relevant passages	Relevant to claim No.
A	WO 2008/013891 A2 (FCI AMERICAS TECHNOLOGY INC [US]; FRAMATOME CONNECTORS INT [FR]; DE FR) 31 January 2008 (2008-01-31) paragraphs [0030] - [0033], [0040]; figures 1-3	1, 14, 21
A	CA 2 092 741 A1 (LARICCHIA ROCCO V [CA]; CACHIA EDGAR C [CA]; COLE RANDAL T [CA]; HILL) 27 September 1994 (1994-09-27) pages 4,5; figures 2,10	1, 14, 21

Further documents are listed in the continuation of Box C.

See patent family annex.

* Special categories of cited documents :

- "A" document defining the general state of the art which is not considered to be of particular relevance
- "E" earlier document but published on or after the international filing date
- "L" document which may throw doubts on priority claim(s) or which is cited to establish the publication date of another citation or other special reason (as specified)
- "O" document referring to an oral disclosure, use, exhibition or other means
- "P" document published prior to the international filing date but later than the priority date claimed

- "T" later document published after the international filing date or priority date and not in conflict with the application but cited to understand the principle or theory underlying the invention
- "X" document of particular relevance; the claimed invention cannot be considered novel or cannot be considered to involve an inventive step when the document is taken alone
- "Y" document of particular relevance; the claimed invention cannot be considered to involve an inventive step when the document is combined with one or more other such documents, such combination being obvious to a person skilled in the art.
- "&" document member of the same patent family

Date of the actual completion of the international search

11 May 2010

Date of mailing of the international search report

19/05/2010

Name and mailing address of the ISA/
European Patent Office, P.B. 5818 Patentlaan 2
NL - 2280 HV Rijswijk
Tel. (+31-70) 340-2040,
Fax: (+31-70) 340-3016

Authorized officer

Findeli, Luc

INTERNATIONAL SEARCH REPORT

International application No.
PCT/US2009/067049

Box No. II Observations where certain claims were found unsearchable (Continuation of item 2 of first sheet)

This international search report has not been established in respect of certain claims under Article 17(2)(a) for the following reasons:

1. Claims Nos.:
because they relate to subject matter not required to be searched by this Authority, namely:

2. Claims Nos.:
because they relate to parts of the international application that do not comply with the prescribed requirements to such an extent that no meaningful international search can be carried out, specifically:

3. Claims Nos.:
because they are dependent claims and are not drafted in accordance with the second and third sentences of Rule 6.4(a).

Box No. III Observations where unity of invention is lacking (Continuation of item 3 of first sheet)

This International Searching Authority found multiple inventions in this international application, as follows:

see additional sheet.

1. As all required additional search fees were timely paid by the applicant, this international search report covers all searchable claims.
2. As all searchable claims could be searched without effort justifying an additional fees, this Authority did not invite payment of additional fees.
3. As only some of the required additional search fees were timely paid by the applicant, this international search report covers only those claims for which fees were paid, specifically claims Nos.:
4. No required additional search fees were timely paid by the applicant. Consequently, this international search report is restricted to the invention first mentioned in the claims; it is covered by claims Nos.:

1-27

Remark on Protest

- The additional search fees were accompanied by the applicant's protest and, where applicable, the payment of a protest fee.
- The additional search fees were accompanied by the applicant's protest but the applicable protest fee was not paid within the time limit specified in the invitation.
- No protest accompanied the payment of additional search fees.

FURTHER INFORMATION CONTINUED FROM PCT/ISA/ 210

This International Searching Authority found multiple (groups of) inventions in this international application, as follows:

1. claims: 1-27

A mounting slot which is arranged to receive an insulator end of an insulator.

2. claims: 28-31

A lockout mechanism which is selectively operable to secure a blade member in an open position.

INTERNATIONAL SEARCH REPORT

Information on patent family members

International application No
PCT/US2009/067049

Patent document cited in search report	Publication date	Patent family member(s)	Publication date
WO 2008013891	A2	31-01-2008	
		CA 2654895 A1	31-01-2008
		US 2008026644 A1	31-01-2008

CA 2092741	A1	27-09-1994	NONE
