



US00D888642S

(12) **United States Design Patent**
Ninov et al.

(10) **Patent No.:** US D888,642 S

(45) **Date of Patent:** ** Jun. 30, 2020

(54) **WHEEL**

(71) Applicants: **Deyan Ninov**, Royal Oak, MI (US);
Gregory A. Howell, Farmington, MI (US)

(72) Inventors: **Deyan Ninov**, Royal Oak, MI (US);
Gregory A. Howell, Farmington, MI (US)

(73) Assignee: **FCA US LLC**, Auburn Hills, MI (US)

(**) Term: **15 Years**

(21) Appl. No.: **29/679,567**

(22) Filed: **Feb. 7, 2019**

(51) **LOC (12) Cl.** **12-16**

(52) **U.S. Cl.**
USPC **D12/209**

(58) **Field of Classification Search**
USPC D12/204–213; D21/563
CPC B60B 7/00; B60B 7/02; B60B 7/04; B60B
7/01; B60B 7/06; B60B 3/02; B60B 3/04;
B60B 3/06; B60B 3/10; B60B 1/00;
B60B 1/08; B60B 1/10; B60B 1/12
See application file for complete search history.

(56) **References Cited**

U.S. PATENT DOCUMENTS

D475,670 S *	6/2003	Chung	D12/209
D489,308 S *	5/2004	Tirado	D12/209
D497,863 S *	11/2004	Cahyono	D12/209
D528,062 S *	9/2006	Hosoi	D12/211
D549,149 S *	8/2007	Thomas	D12/209
D601,075 S *	9/2009	Szavits	D12/211

D623,108 S *	9/2010	Spoerle	D12/209
D625,243 S *	10/2010	Holstein	D12/211
D654,005 S *	2/2012	Mueller-Stolz	D12/209
D654,841 S *	2/2012	Mueller-Stolz	D12/209
D707,167 S *	6/2014	Chung	D12/209
D713,314 S *	9/2014	Platto	D12/209
D715,719 S *	10/2014	Platto	D12/209
D719,889 S *	12/2014	Hodges	D12/209
D730,798 S *	6/2015	Diephuis	D12/209
D732,454 S *	6/2015	Szews	D12/211
D753,573 S *	4/2016	Watkin	D12/211
D755,105 S *	5/2016	Garbas	D12/211
D757,629 S *	5/2016	Hubers	D12/211
D781,197 S *	3/2017	Ninov	D12/209
D787,413 S *	5/2017	Alfonso	D12/211
D805,991 S *	12/2017	Platto	D12/209
D820,184 S *	6/2018	Bucher	D12/209
D823,777 S *	7/2018	Ninov	D12/211
D850,349 S *	6/2019	Lickliter	D12/209
D857,583 S *	8/2019	Harriton	D12/209
D868,664 S *	12/2019	Dewitt	D12/211

* cited by examiner

Primary Examiner — Stacia A Cadmus

(74) *Attorney, Agent, or Firm* — Ralph E. Smith

(57) **CLAIM**

The ornamental design for a wheel, as shown and described.

DESCRIPTION

FIG. 1 is a front view of a wheel showing our new design; FIG. 2 is a right perspective view thereof; and, FIG. 3 is a left perspective view thereof.

It will be understood that the broken lines shown in the drawings illustrate portions of the wheel that form no part of the claimed design.

1 Claim, 3 Drawing Sheets

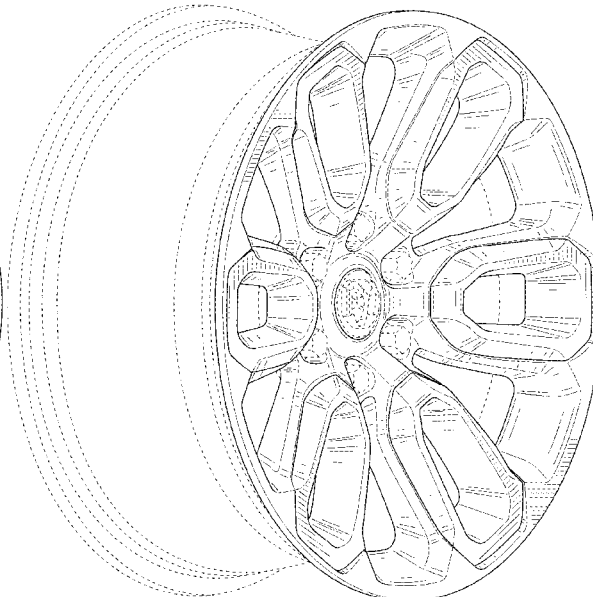
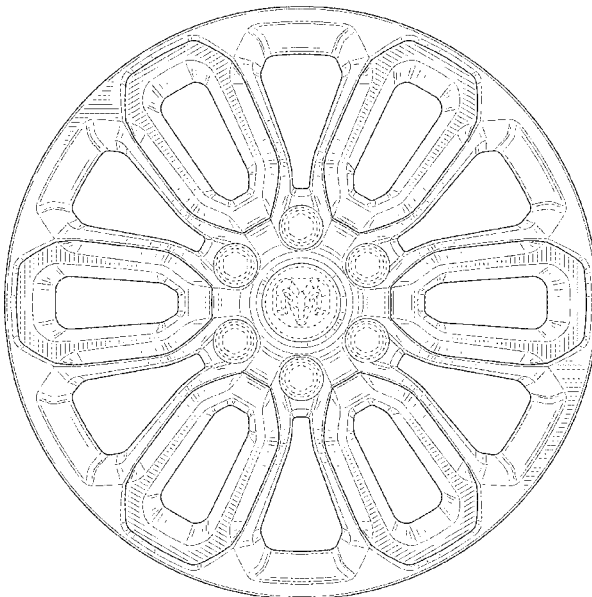

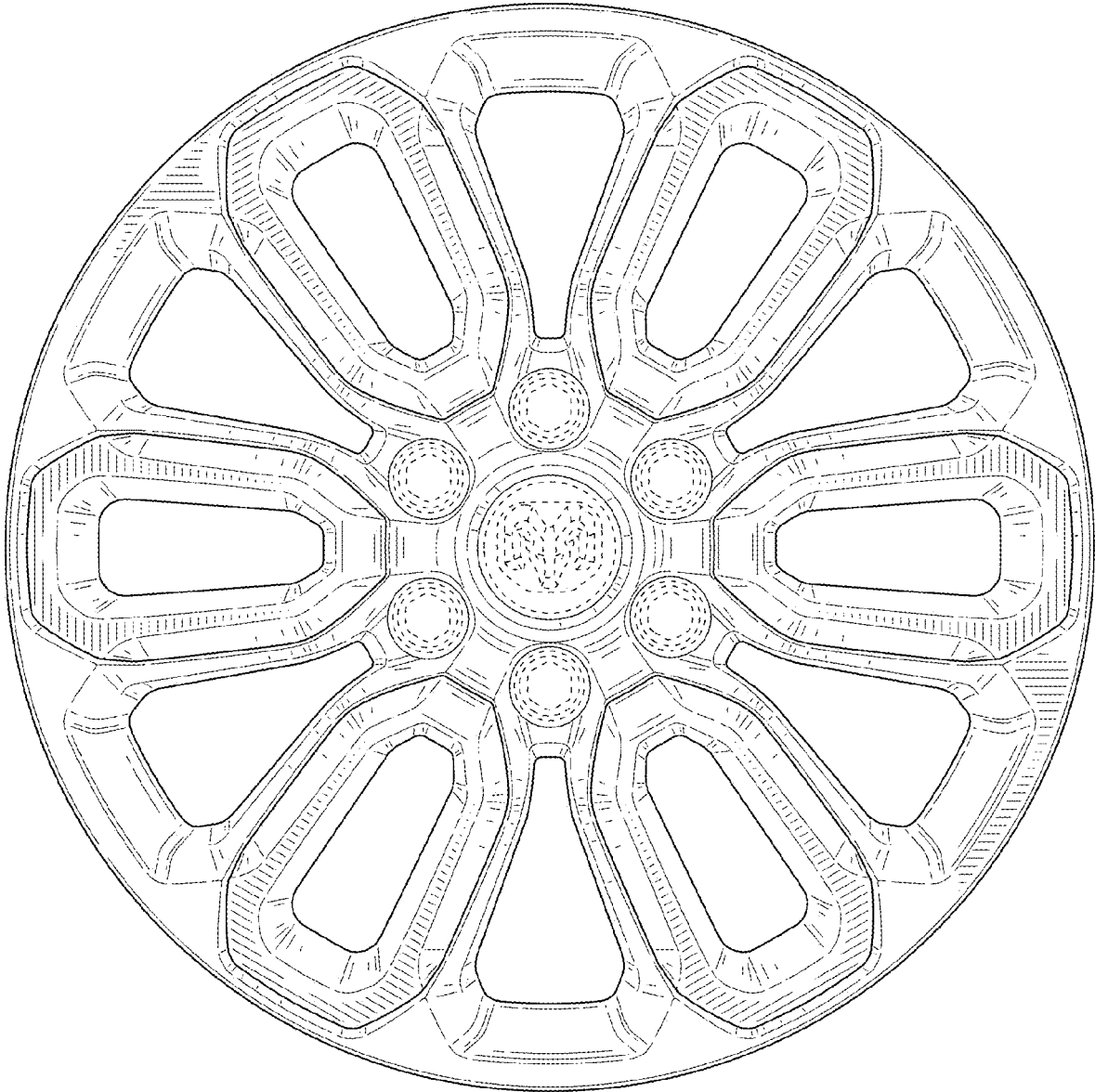

FIG. 1

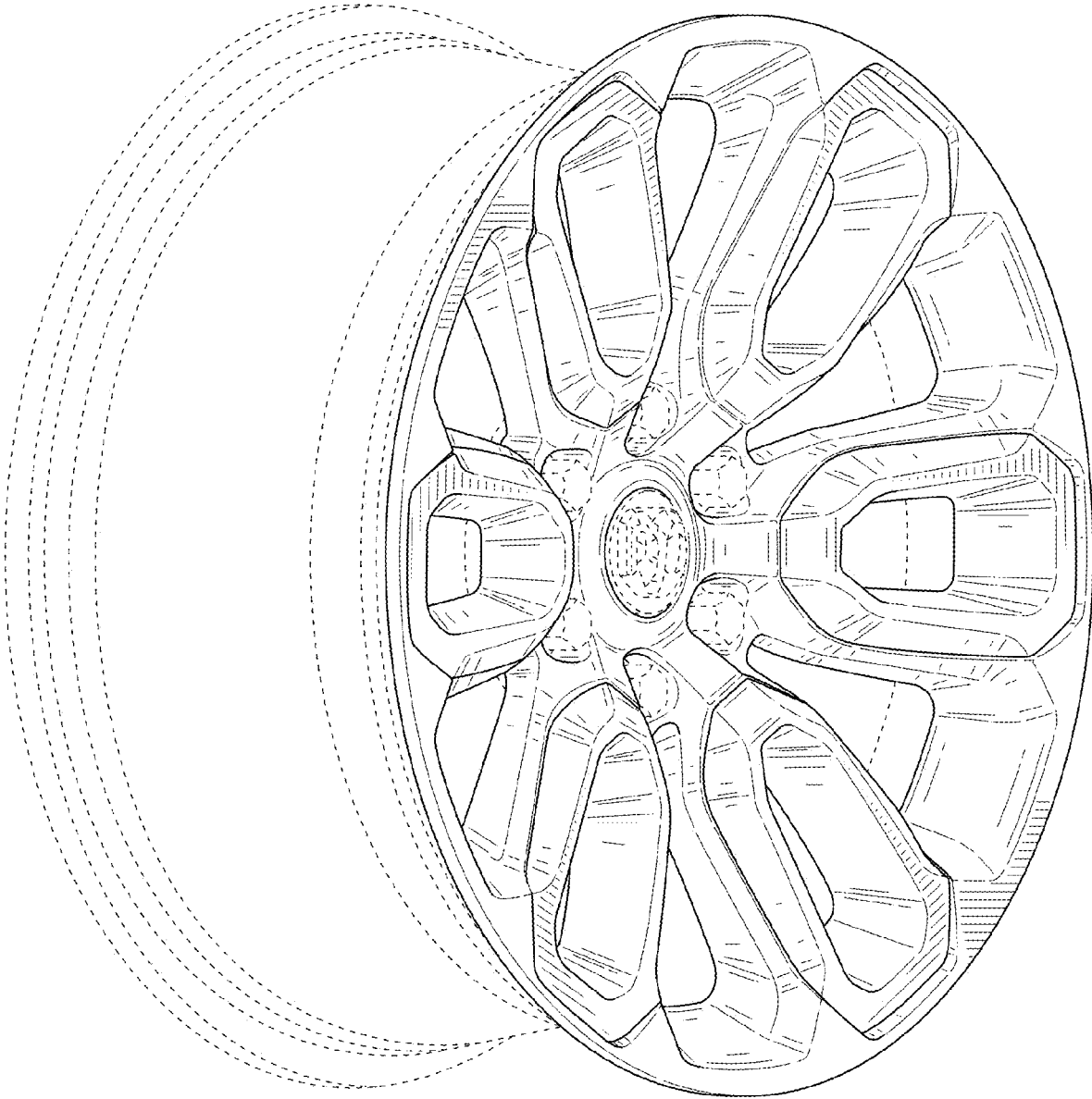

FIG. 2

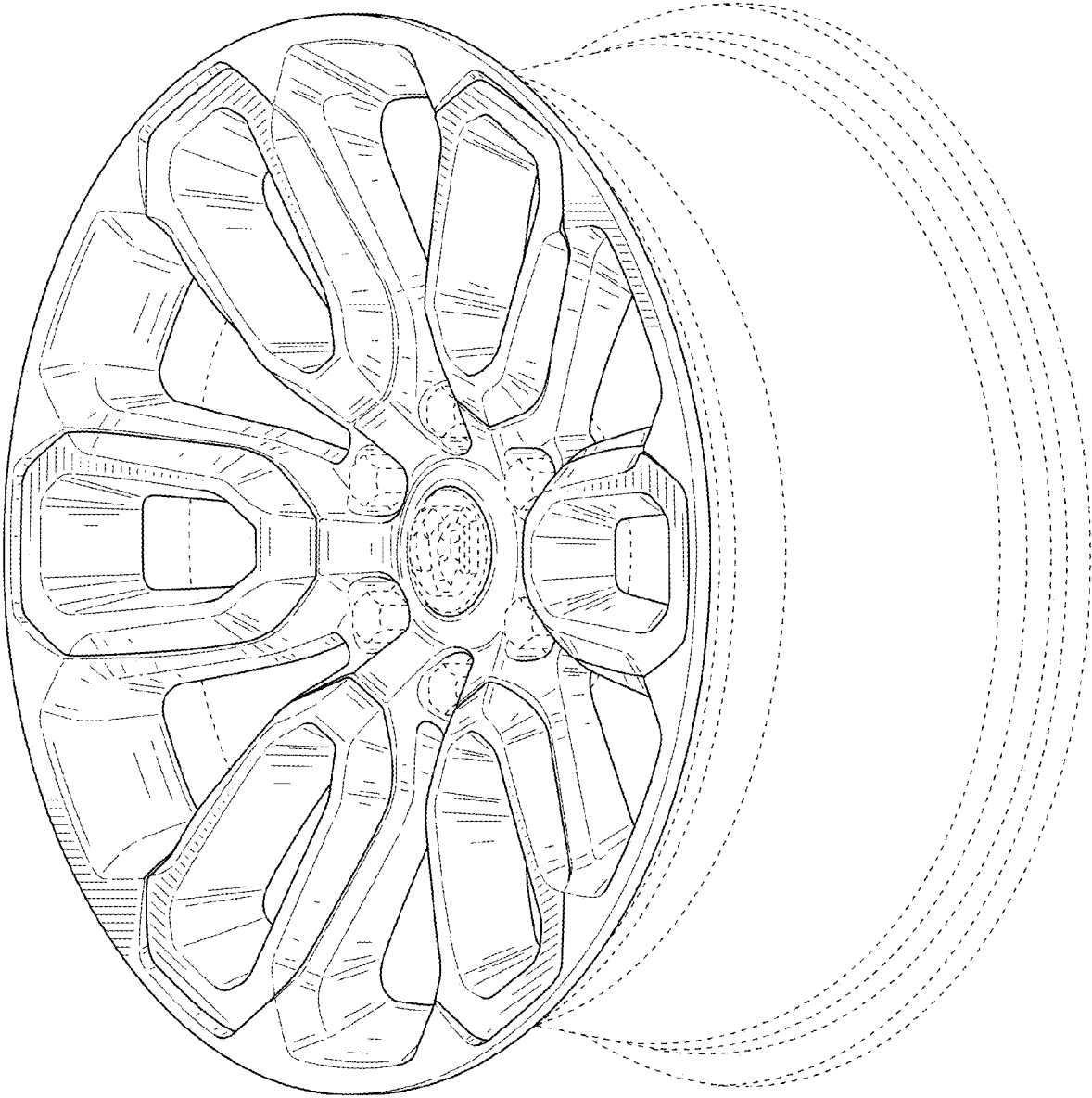

FIG. 3