



INTERNATIONAL APPLICATION PUBLISHED UNDER THE PATENT COOPERATION TREATY (PCT)

(51) International Patent Classification ⁵ : D21F 3/02	A1	(11) International Publication Number: WO 91/08339 (43) International Publication Date: 13 June 1991 (13.06.91)
<p>(21) International Application Number: PCT/US90/04773</p> <p>(22) International Filing Date: 22 August 1990 (22.08.90)</p> <p>(30) Priority data: 441,800 27 November 1989 (27.11.89) US</p> <p>(71) Applicant: BELOIT CORPORATION [US/US]; One St. Lawrence Avenue, Beloit, WI 53511 (US).</p> <p>(72) Inventors: CROUSE, Jere, W. ; 3521 Circle Wood Drive, Beloit, WI 53511 (US). PORTER, Roy, J. ; R.R. 5, Suburban Drive, Beloit, WI 53511 (US).</p> <p>(74) Agent: ARCHER, David, J.; One St. Lawrence Avenue, Beloit, WI 53511 (US).</p>	<p>(81) Designated States: AT, AT (European patent), AU, BB, BE (European patent), BF (OAPI patent), BG, BJ (OAPI patent), BR, CA, CF (OAPI patent), CG (OAPI patent), CH, CH (European patent), CM (OAPI patent), DE*, DE (European patent)*, DK, DK (European patent), ES, ES (European patent), FI, FR (European patent), GA (OAPI patent), GB, GB (European patent), HU, IT (European patent), JP, KP, KR, LK, LU, LU (European patent), MC, MG, ML (OAPI patent), MR (OAPI patent), MW, NL, NL (European patent), NO, RO, SD, SE, SE (European patent), SN (OAPI patent), SU, TD (OAPI patent), TG (OAPI patent).</p> <p>Published <i>With international search report.</i> <i>With amended claims.</i></p>	

(54) Title: A PRESS SECTION APPARATUS

(57) Abstract

A press section apparatus (10) is disclosed for pressing water from a formed web (W). The apparatus (10) includes a press frame (12) and a backing roll (14) rotatably supported by the frame (12). An elongate pressing device (16) cooperates with the backing roll (14) for defining therebetween an elongate pressing section (18) for pressing water from the formed web (W). A looped bearing blanket (20) extends through the pressing section (18) with the blanket (20) being disposed between the pressing device (16) and the backing roll (14) for supporting the web (W) during passage of the web (W) through the pressing section (18). A heater (22) is disposed adjacent to the backing roll (14) for heating the backing roll (14) such that the web (W) extending through the pressing section (18) is subjected to an increased temperature and pressure for an extended period so that water vapor generated within the web (W) during passage of the web (W) through the pressing section (18) drives off from the web (W) water within the web (W) in the liquid phase. The apparatus (10) also includes a felt (30) disposed between the web (W) and the blanket (20) for permitting the water in the liquid phase to be vented from the pressing section (18) and a further felt (32) for absorbing and transporting the water in the liquid phase away from the pressing section (18) so that delamination of the pressed web (W) is inhibited.

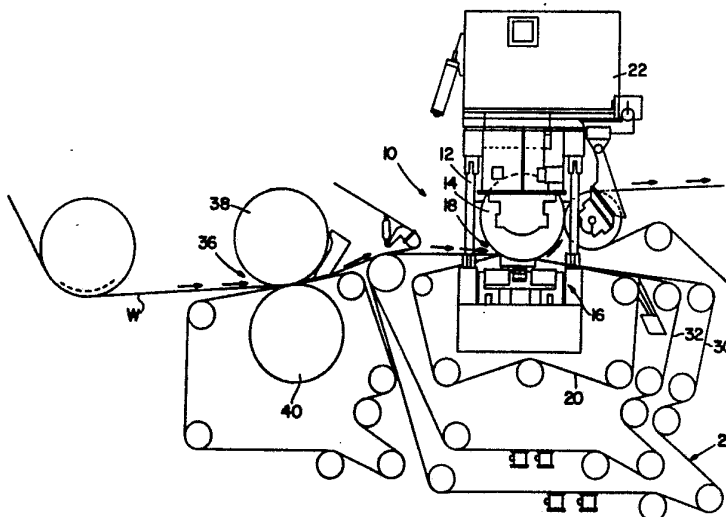

DESIGNATIONS OF "DE"

Until further notice, any designation of "DE" in any international application whose international filing date is prior to October 3, 1990, shall have effect in the territory of the Federal Republic of Germany with the exception of the territory of the former German Democratic Republic.

FOR THE PURPOSES OF INFORMATION ONLY

Codes used to identify States party to the PCT on the front pages of pamphlets publishing international applications under the PCT.

AT	Austria	FI	Finland	ML	Mali
AU	Australia	FR	France	MN	Mongolia
BB	Barbados	GA	Gabon	MR	Mauritania
BE	Belgium	GB	United Kingdom	MW	Malawi
BF	Burkina Faso	GN	Guinea	NL	Netherlands
BG	Bulgaria	GR	Greece	NO	Norway
BJ	Benin	HU	Hungary	PL	Poland
BR	Brazil	IT	Italy	RO	Romania
CA	Canada	JP	Japan	SD	Sudan
CF	Central African Republic	KP	Democratic People's Republic of Korea	SE	Sweden
CG	Congo	KR	Republic of Korea	SN	Senegal
CH	Switzerland	LI	Liechtenstein	SU	Soviet Union
CI	Côte d'Ivoire	LK	Sri Lanka	TD	Chad
CM	Cameroon	LU	Luxembourg	TG	Togo
DE	Germany	MC	Monaco	US	United States of America
DK	Denmark	MG	Madagascar		
ES	Spain				

PATENT APPLICATION

TITLE: A PRESS SECTION APPARATUS

BACKGROUND OF THE INVENTION

FIELD OF THE INVENTION

The present invention relates to a press section apparatus for pressing water from a formed web. More particularly, the present invention relates to a press section apparatus in which the web is subjected to an increased temperature and pressure for an extended period for pressing water from the formed web.

INFORMATION DISCLOSURE STATEMENT

U.S. Patent No. 4,738,752 to Busker et al describes a heated extended nip press apparatus which enables an improved removal of water from a formed web.

More particularly, U.S. Patent No. 4,738,752 teaches that when the backing roll of an extended nip press is heated, water vapor is generated within the web extending through a pressing section defined between the backing roll and a pressing shoe. Such water vapor urges water within the web in the liquid phase away from the web into a felt running contiguously with the web through the pressing section.

Although the aforementioned arrangement has been very successful in removing water from heavy paper grades and board, problems have been experienced when applying the aforementioned principles to lightweight grades, such as newsprint and the like. More particularly, with the lighter grades, there exists a tendency for the web to delaminate as the pressed web exits from the pressing section.

Many proposals have been set forth in an attempt to overcome the problem of delamination. Included among such proposals is that set forth in the aforementioned patent to

Busker et al which teaches a porous layer on the backing roll for absorbing a portion of the water vapor generated during passage of the web through the pressing section.

The present invention, however, provides a simple and relatively inexpensive means for inhibiting delamination of the pressed web by the provision of a felt and further felt disposed between the web and a bearing blanket. The present invention also provides alternatively a composite felt including a first layer for permitting the unimpeded passage therethrough of water in the liquid phase and a second hygroscopic layer for absorbing and transporting the water away from the pressing section.

Therefore, it is a primary object of the present invention to provide a press section apparatus that overcomes the aforementioned problems associated with the prior art proposals and which makes a considerable contribution to the art of pressing water from a formed web.

Another object of the present invention is the provision of a press section apparatus in which the web is subjected to an increased temperature and pressure for an extended period so that water vapor generated within the web during passage of the web through the pressing section drives off from the web water within the web in the liquid phase. The water in the liquid phase and the water vapor are vented through a felt and the water in the liquid phase is absorbed in a hygroscopic further felt disposed between the felt and a bearing blanket.

Another object of the present invention is the provision of a press section apparatus which includes a felt means comprising a composite felt having a first layer of absorbant material. The first layer is of open construction for permitting unimpeded passage therethrough of water in the liquid phase and water vapor. A second layer of hygroscopic material absorbs the water in the liquid phase. The second layer also transports the water in the liquid phase away from

the pressing section so that delamination of the pressed web is inhibited.

Another object of the present invention is the provision of a press section apparatus which includes a steam box which is disposed adjacent to the web and immediately upstream relative to a pressing section for pre-steaming the web so that the removal of water therefrom is facilitated.

Another object of the present invention is the provision of a press section apparatus which includes a guide roll which is disposed downstream relative to the pressing section for guiding the felt such that when the felt and the further felt diverge relative to each other, the felt follows the backing roll and is guided around the guide roll away from the backing roll.

Another object of the present invention is the provision of a press section apparatus in which the felt is fabricated from heat resistant fibers so that the felt supports the web during movement of the web around the backing roll.

Another object of the present invention is the provision of a press section apparatus in which the felt defines a fine, smooth face disposed contiguously relative to the web for inhibiting marking of the pressed web.

Another object of the present invention is the provision of a press section apparatus in which the felt is constructed of heat resistant fibers so that during operation of the press section apparatus, the felt remains dry.

Other objects and advantages of the present invention will be readily apparent to those skilled in the art by a consideration of the detailed description contained hereinafter taken in conjunction with the annexed drawings.

SUMMARY OF THE INVENTION

The present invention relates to a press section apparatus and method for pressing water from a formed web. The apparatus includes a press frame and a backing roll which is rotatably supported by the frame. An elongate pressing means cooperates with the backing roll for defining therebetween an elongate pressing section for pressing water from the formed web. A looped bearing blanket extends through the pressing section with the blanket being disposed between the pressing means and the backing roll for supporting the web during passage of the web through the pressing section. A heating means is disposed adjacent to the backing roll for heating the backing roll so that the web extending through the pressing section is subjected to an increased temperature and pressure for an extended period such that water vapor generated within the web during passage of the web through the pressing section drives off from the web water within the web in the liquid phase. The apparatus also includes felt means disposed between the web and the blanket for permitting the water in the liquid phase to be vented from the pressing section and for absorbing and transporting water in the liquid phase away from the pressing section so that delamination of the pressed web is inhibited.

In one embodiment of the present invention, the elongate pressing means is a hydrodynamic shoe whereas in another embodiment of the present invention, the elongate pressing means is a hydrostatic shoe.

In both embodiments of the present invention, the bearing blanket defines a smooth, impervious surface which is disposed towards the backing roll.

However, in another embodiment of the present invention, the blanket defines a textured surface.

In a further embodiment, the blanket is vented.

The heating means in a preferred embodiment of the present invention is an induction heater disposed upstream relative to the pressing section.

In one embodiment of the present invention, the felt means includes a felt which is disposed between the web and the blanket for permitting the water in the liquid phase and the water vapor to pass therethrough. The felt means also includes a further felt disposed between the felt and the blanket for absorbing and transporting the water in the liquid phase away from the pressing section so that delamination of the pressed web is inhibited.

In an alternative embodiment of the present invention, the felt means is a composite felt which includes a first layer of absorbant material of open construction for permitting unimpeded passage therethrough of water in the liquid phase. The felt means also includes a second layer of hygroscopic material for absorbing the water in the liquid phase and for transporting the water in the liquid phase away from the pressing section so that delamination of the pressed web is inhibited.

In a more specific embodiment of the present invention, the press section apparatus includes a press roll means which is disposed upstream relative to the pressing section for initiating the removal of water from the web.

Additionally, the press section apparatus includes a steam box means which is disposed adjacent to the web and immediately upstream relative to the pressing section for pre-steaming the web so that removal of water therefrom is facilitated.

In a further embodiment of the present invention, the press section apparatus includes a guide roll which is disposed downstream relative to the pressing section for guiding the felt such that when the felt diverges relative to the further felt downstream relative to the pressing section,

the felt follows the backing roll and is guided around the guide roll away from the backing roll.

More particularly, the felt is fabricated from heat resistant fibers such that during operation of the press section apparatus, the felt remains dry. Also, the felt defines a face which is disposed contiguously relative to the formed web, the face having a fine, smooth surface for inhibiting marking of the pressed web.

The present invention also includes a method for pressing water from a formed web. The method includes the steps of: initially dewatering the formed web by passing the formed web between cooperating press rolls;

applying steam to the pressed web immediately upstream relative to an extended pressing section;

guiding the web through the extended pressing section such that the web is subjected for an extended period to increased temperature and pressure such that water vapor generated within the web during passage of the web through the pressing section drives off from the web any water in the liquid phase remaining in the web;

permitting such driven off water in the liquid phase to pass unimpeded through a felt extending contiguously with the web through the pressing section;

guiding a further felt disposed contiguously with the felt through the pressing section such that the felt is disposed between the web and the further felt, the further felt absorbing the water in the liquid phase driven off from the web such that the water in the liquid phase is carried away from the pressing section.

Many modifications and variations of the present invention will be readily apparent to those skilled in the

art by a consideration of the detailed description taken in conjunction with the annexed drawings.

However, such modifications and variations fall within the spirit and scope of the present invention as defined by the appended claims.

BRIEF DESCRIPTION OF THE DRAWINGS

Figure 1 is an elevational view of a press section apparatus according to the present invention;

Figure 2 is an enlarged view of the pressing section shown in Figure 1 showing a hydrodynamic shoe;

Figure 3 is a similar view to that shown in Figure 2 but shows an alternative embodiment of the present invention including a hydrostatic shoe;

Figure 4 is a sectional view of an alternative embodiment of the present invention showing a composite felt;

Figure 5 is a side-elevational view similar to that shown in Figure 1 but shows an alternative embodiment of the present invention including a steam box; and

Figure 6 is a side-elevational view of yet another embodiment of the present invention which includes a guide roll for guiding the felt away from the backing roll.

Similar reference characters refer to similar parts throughout the various embodiments of the present invention.

DETAILED DESCRIPTION OF THE DRAWINGS

Figure 1 is a side-elevational view of a press section apparatus generally designated 10 according to the present invention for pressing water from a formed web W.

The apparatus 10 includes a press frame 12 and a backing roll 14 rotatably supported by the frame 12. An elongate pressing means generally designated 16 cooperates with the backing roll 14 for defining therebetween an elongate pressing section 18 for pressing water from the formed web W.

A looped bearing blanket 20 extends through the pressing section 18. The bearing blanket 20 is disposed between the pressing means 16 and the backing roll 14 for supporting the web W during passage of the web W through the pressing section 18.

Heating means 22 is disposed adjacent to the backing roll 14 for heating the backing roll 14 such that the web W extending through the pressing section 18 is subjected to an increased temperature and pressure for an extended period so that water vapor generated within the web W during passage of the web W through the pressing section 18 drives off from the web W water within the web W in the liquid phase.

The press section apparatus 10 also includes felt means generally designated 24 which is disposed between the web W and the blanket 20 for permitting the water in the liquid phase to be vented from the pressing section 18 and for absorbing and transporting the water in the liquid phase away from the pressing section 18 so that delamination of the pressed web W is inhibited.

Figure 2 is an enlarged elevational view of one embodiment of the present invention in which the elongate pressing means 16 is a hydrodynamic shoe 26.

In another embodiment of the present invention as shown in Figure 3, the elongate pressing means 16A is a hydrostatic shoe 26A.

In one of the embodiments of the present invention, the bearing blanket 20 defines a smooth, impervious surface 28 which is disposed towards the backing roll 14.

In another embodiment, the surface is textured. In yet another embodiment, the blanket is vented. Such venting may include grooving or blind drilling.

The heating means 22 shown in Figure 1 of the present invention is an induction heater which is disposed upstream relative to the pressing section 18.

As shown in Figure 1, the felt means generally designated 24 includes a felt 30 which is disposed between the web W and the blanket 20 for permitting the water in the liquid phase and the water vapor to pass therethrough. The felt means 24 also includes a further felt 32 which is disposed between the felt 30 and the blanket 20 for absorbing and transporting the water in the liquid phase away from the pressing section 18 so that delamination of the pressed web W is inhibited.

Figure 4 is an enlarged section view of an alternative embodiment of the present invention in which a felt means 24B is a composite felt generally designated 34 which includes a first layer 30B of absorbant material of open construction for permitting unimpeded passage therethrough of water in the liquid phase and the passage of water vapor therethrough. The composite felt 34 also includes a second layer 32B of hygroscopic material for absorbing the water in the liquid phase and for transporting the water in the liquid phase away from the pressing section so that delamination of the pressed web WB is inhibited.

Figure 1 also shows a press roll means generally designated 36 including a first and a second press roll 38 and 40 respectively which are disposed upstream relative to the pressing section 18. The press rolls 38 and 40 cooperate together for initiating the removal of water from the web W.

Figure 5, is a similar view to that shown in Figure 1 but shows an alternative embodiment of the present invention. Figure 5 shows an apparatus 10C including a steam box means generally designated 40 which is disposed adjacent to a web WC and immediately upstream relative to the pressing section 18C for pre-steaming the web WC so that removal of water therefrom is facilitated.

More particularly, the steam box means 40 includes a steam box 42 and a vacuum box 44 so that steam is drawn by the vacuum box 44 into the formed web WC.

Figure 6 shows an alternative embodiment of the present invention which includes a guide roll 46 disposed downstream relative to a pressing section 18D for guiding a felt 30D such that when the felt 30D diverges relative to a further felt 32D downstream relative to the pressing section 18D, the felt 30D follows a backing roll 14D and is guided around the guide roll 46 away from the backing roll 14D.

The felt 30D as in the other embodiments of the present invention is fabricated from heat resistant fibers.

Also, the felt 30D defines a face 48 which is disposed contiguously relative to the formed web WD. The face 48 has a fine, smooth surface for inhibiting marking of the pressed web WD.

In operation of the apparatus, as shown in Figure 1 the web W is initially dewatered during passage through the press means 36. The web is then transferred to the felt 30 which transports the initially dewatered web through the pressing section 18. The backing roll 14 is heated to a temperature within the range 400 - 700° Fahrenheit so that as the web extends through the pressing section 18, water vapor is generated within the web W. Such water vapor drives off any water in the liquid phase remaining in the web. Such water in the liquid phase passes unimpeded through the felt 30 and

is absorbed by the further felt 32 so that the water in the liquid phase is transported away from the pressing section 18.

In operation of the alternative embodiment of the present invention as shown in Figure 5, a steam box 42 and a vacuum box 44 are disposed immediately upstream relative to the pressing section 18C so that steam is drawn into the initially dewatered web, thereby facilitating removal of water therefrom during passage of the web through the pressing section 18C.

In operation of the embodiment shown in Figure 6, the felt 30D is guided around the guide roll 46 so that the felt 30D supports the web WD during passage of the web WD around the backing roll 14D. Thereafter, the felt 30D guides the pressed web away from the backing roll 14D so that the web supported by the felt 30D extends away from the backing roll 14D.

The present invention provides a simple and relatively inexpensive means for avoiding the problem of delamination in a press section apparatus having a heated backing roll.

What is claimed:

1. A press section apparatus (10) for pressing water from a formed web (W), said apparatus (10) comprising:

a press frame (12);

a backing roll (14) rotatably supported by said frame (12);

elongate pressing means (16) cooperating with said backing roll (14) for defining therebetween an elongate pressing section (18) for pressing water from the formed web (W);

a looped bearing blanket (20) extending through said pressing section (18), said blanket (20) being disposed between said pressing means (16) and said backing roll (14) for supporting the web (W) during passage of the web (W) through said pressing section (18);

heating means (22) disposed adjacent to said backing roll (14) for heating said backing roll (14) such that the web (W) extending through said pressing section (18) is subjected to an increased temperature and pressure for an extended period so that water vapor generated within the web (W) during passage of the web (W) through the pressing section (18) drives off from the web (W) water within the web (W) in the liquid phase; and

felt means (24) disposed between the web (W) and said blanket (20) for permitting said water in said liquid phase to be vented from said pressing section (18) and for absorbing and transporting said water in said liquid phase away from said pressing section (18) so that delamination of the pressed web (W) is inhibited.

2. An apparatus as set forth in claim 1 wherein said elongate pressing means (16) is a hydrodynamic shoe (26).

3. A press section apparatus as set forth in claim 1 wherein said elongate pressing means (16A) is a hydrostatic shoe (26A).
4. A press section apparatus as set forth in claim 1 wherein said bearing blanket (20) defines a smooth, impervious surface (28) disposed towards said backing roll (14).
5. A press section apparatus as set forth in claim 1 wherein said bearing blanket (20) defines a textured surface disposed towards said backing roll (14).
6. A press section apparatus as set forth in claim 1 wherein said bearing blanket (20) defines a vented surface.
7. A press section apparatus as set forth in claim 1 wherein said heating means (22) is an induction heater disposed upstream relative to said pressing section (18).
8. A press section apparatus as set forth in claim 1 wherein said felt means (24) includes:
 - a felt (30) disposed between the web (W) and said blanket (20) for permitting said water in said liquid phase and said water vapor to pass therethrough; and
 - a further felt (32) disposed between said felt (30) and said blanket (20) for absorbing and transporting said water in said liquid phase away from said pressing section (18) so that delamination of the pressed web (W) is inhibited.
9. A press section apparatus as set forth in claim 1 wherein said felt means (24B) is a composite felt (34) including:
 - a first layer (30B) of absorbant material of open construction for permitting unimpeded passage therethrough of water in said liquid phase and said water vapor therethrough;

a second layer (32B) of hygroscopic material for absorbing said water in said liquid phase and for transporting said water in said liquid phase away from said pressing section so that delamination of the pressed web (W) is inhibited.

10. A press section apparatus as set forth in claim 1 further including:

press roll means (36) disposed upstream relative to said pressing section (18) for initiating the removal of water from the web (W).

11. A press section apparatus as set forth in claim 1 further including:

a steam box means (40) disposed adjacent to the web (W) and immediately upstream relative to said pressing section (18C) for pre-steaming the web (WC) so that removal of water therefrom is facilitated.

12. A press section apparatus for pressing water from a formed web (W), said apparatus comprising:

a press frame (12);

a backing roll (14) rotatably supported by said frame (12);

elongate pressing means (16) cooperating with said backing roll (14) for defining therebetween an elongate pressing section (18) for pressing water from the formed web (W);

a looped bearing blanket (20) extending through said pressing section (18), said blanket (20) being disposed between said pressing means (16) and said backing roll (14) for supporting the web (W) during passage of the web (W) through said pressing section (18);

heating means (22) disposed adjacent to said backing roll (14) for heating said backing roll (14) such that the web (W) extending through said pressing section (18) is subjected to increased temperature and pressure for an extended period so that water

vapor generated within the web (W) during passage of the web (W) through the pressing section (18) drives off from the web (W) water within the web (W) in the liquid phase;

- a felt (30) disposed between the web (W) and said blanket (20) for permitting said water in said liquid phase to pass therethrough; and
- a further felt (32) disposed between said felt (30) and said blanket (20) for absorbing and transporting said water in said liquid phase away from said pressing section (18) so that delamination of the pressed web (W) is inhibited.

13. A press section apparatus as set forth in claim 12 further including:

- a press means (36) disposed upstream relative to said pressing section (18) for initiating removal of water from the formed web (W);
- a steam box means (40) disposed adjacent to the formed web (WC) and immediately upstream relative to said pressing section (18C); and
- a guide roll (46) disposed downstream relative to said pressing section (18D) for guiding said felt (30D) such that when said felt (30D) diverges relative to said further felt (32D) downstream relative to said pressing section (18D), said felt (30D) follows said backing roll (14D) and is guided around said guide roll (46) away from said backing roll (14D).

14. A press section apparatus as set forth in claim 12 wherein said felt (30D) is fabricated from heat resistant fibers.

15. A press section apparatus as set forth in claim 12 wherein said felt (30D) defines a face (48) disposed contiguously relative to the formed web (WD), said face (48) having a fine, smooth surface for inhibiting marking of the pressed web (WD).

16. A press section apparatus as set forth in claim 12 wherein said felt (30D) is constructed of heat resistant fibers.

17. A method for pressing water from a formed web, said method comprising the steps of:

initially dewatering the formed web (W) by passing the formed web (W) between cooperating press rolls (36);

applying steam to the pressed web (W) immediately upstream relative to an extended pressing section (18);

guiding the web (W) through the extended pressing section (18) such that the web (W) is subjected for an extended period to increased temperature and pressure such that water vapor generated within the web (W) during passage of the web (W) through the pressing section (18) drives off from the web (W) any water in the liquid phase remaining in the web (W);

permitting such driven off water in the liquid phase to pass unimpeded through a felt (30) extending contiguously with the web (W) through the pressing section (18); and

guiding a further felt (32) disposed contiguously with the felt (30) through the pressing section (18) such that the felt (30) is disposed between the web (W) and the further felt (32), the further felt (32) absorbing the water in the liquid phase driven off from the web (W) such that the water in the liquid phase is carried away from the pressing section (18).

AMENDED CLAIMS

[received by the International Bureau
on 21 January 1991(21.01.91);
original claim 1 amended;
other claims unchanged
(2 pages)]

1. A press section apparatus (10) for pressing water from a formed web (W), said apparatus (10) comprising:
 - a press frame (12);
 - a backing roll (14) rotatably supported by said frame (12);
 - elongate pressing means (16) cooperating with said backing roll (14) for defining therebetween an elongate pressing section (18) for pressing water from the formed web (W);
 - a looped bearing blanket (20) extending through said pressing section (18), said blanket (20) being disposed between said pressing means (16) and said backing roll (14) for supporting the web (W) during passage of the web (W) through said pressing section (18);
 - heating means (22) disposed adjacent to said backing roll (14) for heating said backing roll (14) such that the web (W) extending through said pressing section (18) is subjected to an increased temperature and pressure for an extended period so that water vapor generated within the web (W) during passage of the web (W) through the pressing section (18) drives off from the web (W) water within the web (W) in the liquid phase;
 - felt means (24) disposed between the web (W) and said blanket (20) for permitting said water in said liquid phase to be vented from said pressing section (18) and for absorbing and transporting said water in said liquid phase away from said pressing section (18) so that delamination of the pressed web (W) is inhibited;
- said felt means (24) including:
 - a felt (30) disposed between the web (W) and said blanket (20) for permitting said water in said liquid phase and said water vapor to pass therethrough; and

a further felt (32) disposed between said felt (30) and said blanket (20) for absorbing and transporting said water in said liquid phase away from said pressing section (18) so that delamination of the pressed web (W) is inhibited.

2. An apparatus as set forth in claim 1 wherein said elongate pressing means (16) is a hydrodynamic shoe (26).

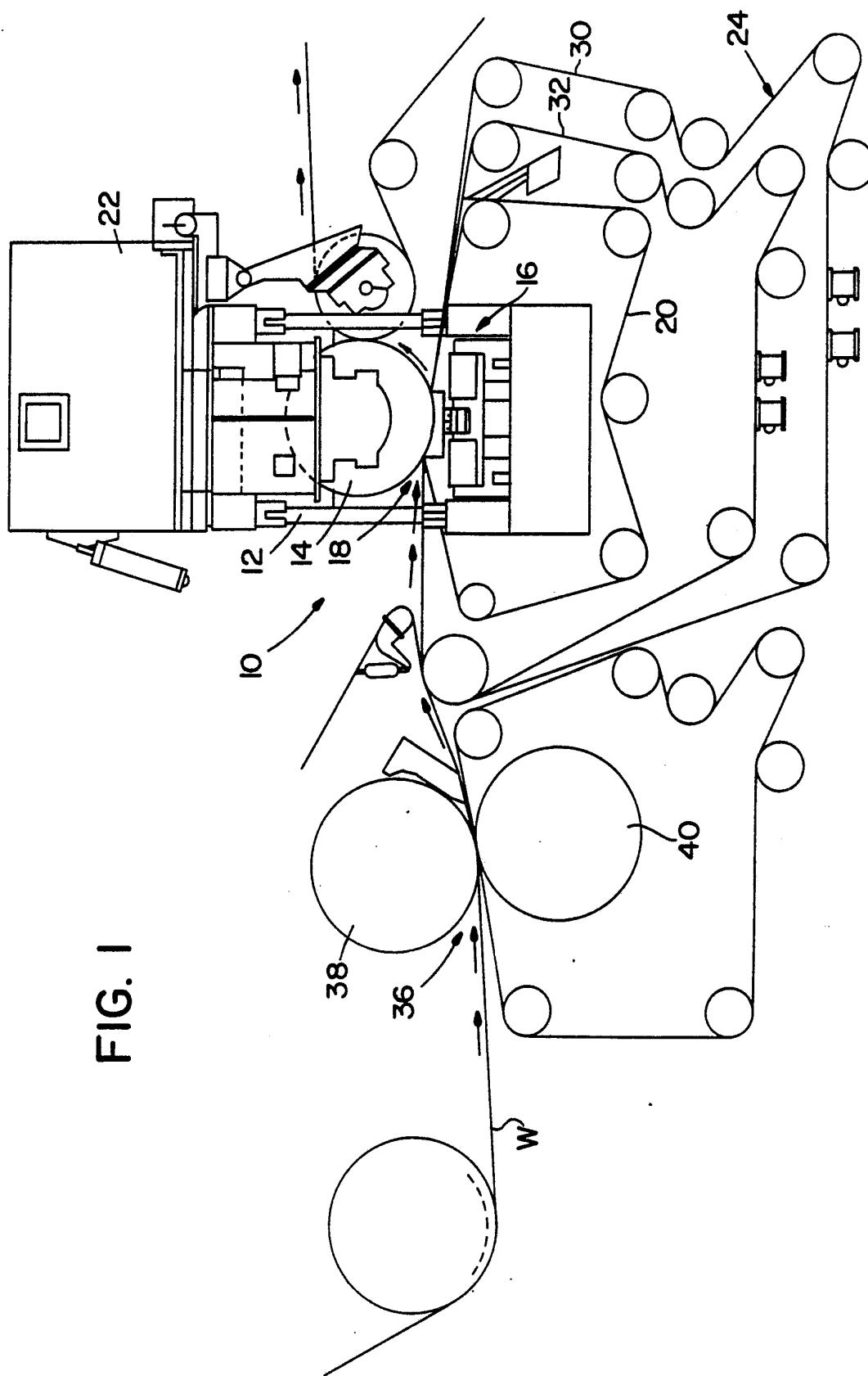

FIG. 1

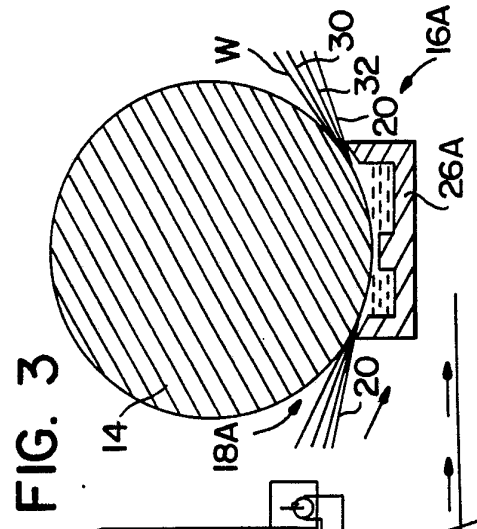

FIG. 3

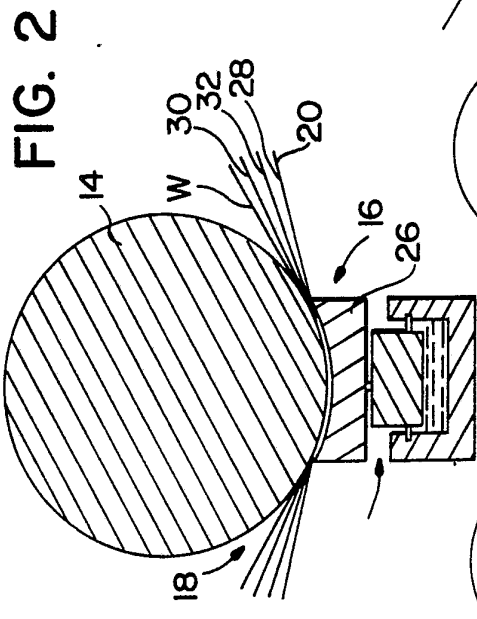

FIG. 2

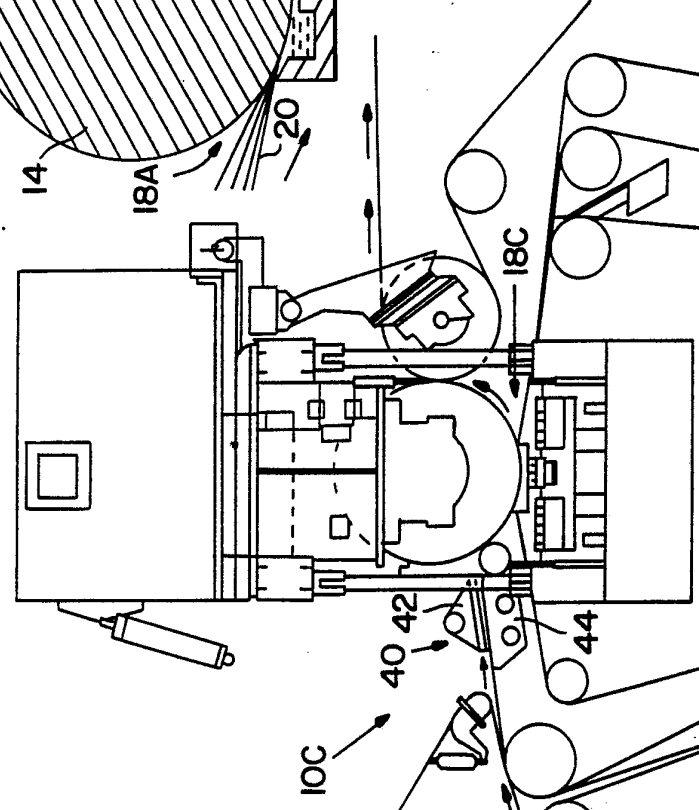

FIG. 5

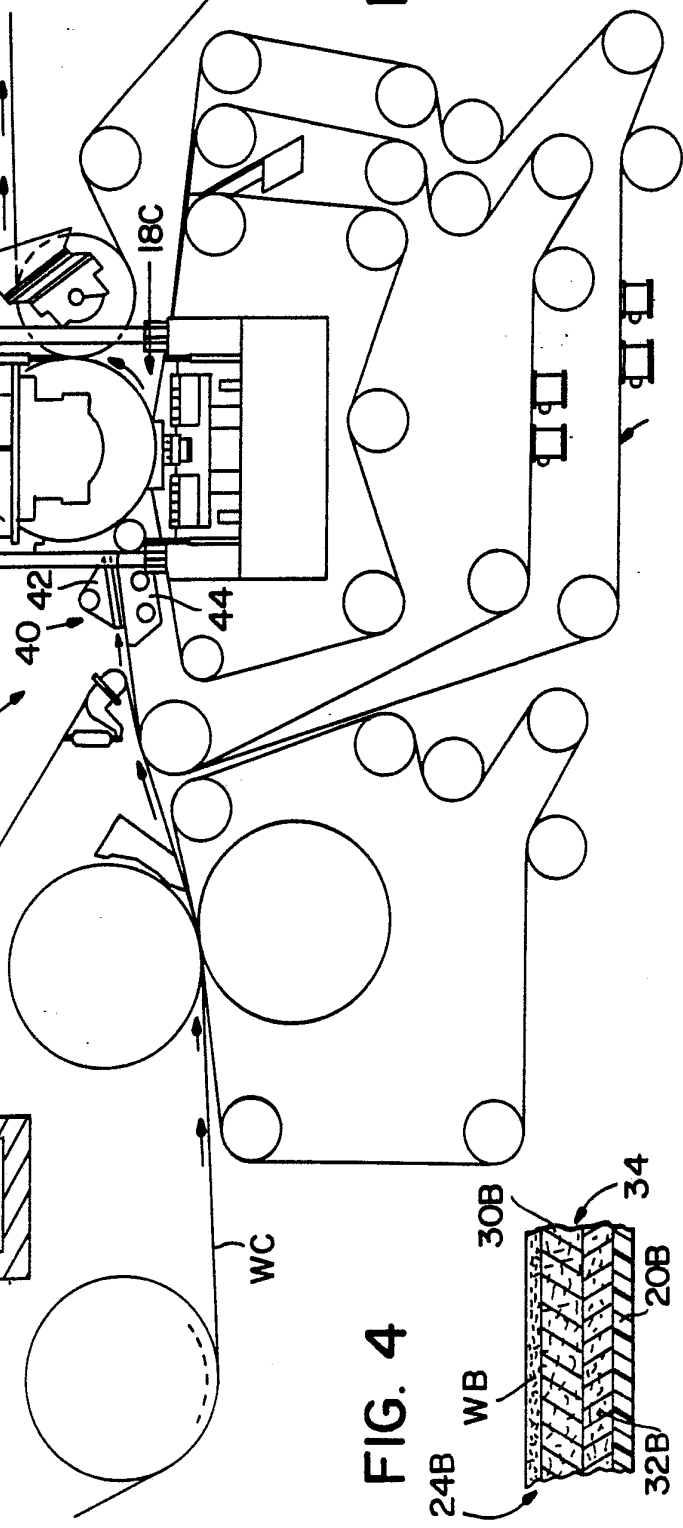
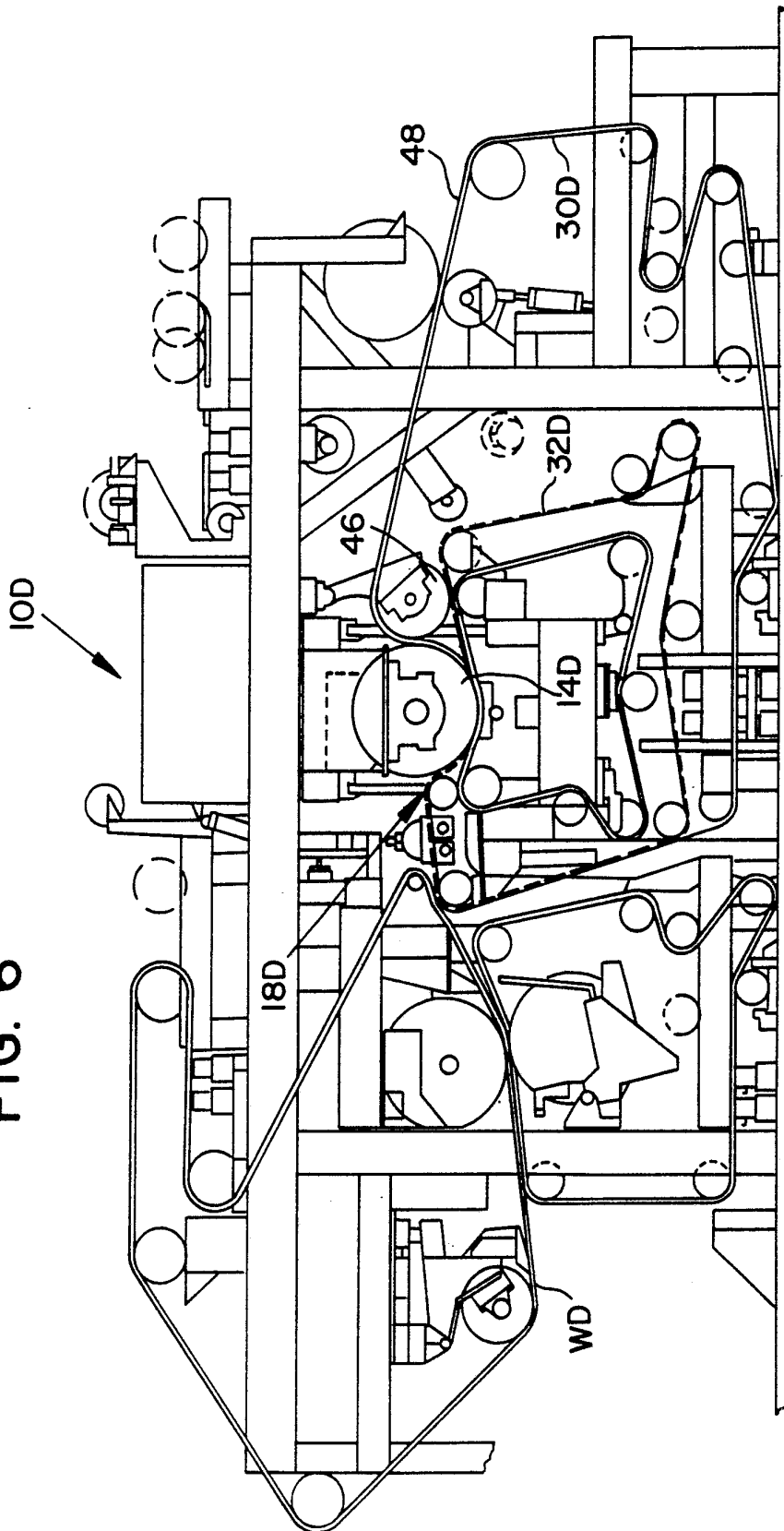

FIG. 4

FIG. 6



INTERNATIONAL SEARCH REPORT

International Application No

PCT/US 90/04773

I. CLASSIFICATION OF SUBJECT MATTER (if several classification symbols apply, indicate all) ⁶		
According to International Patent Classification (IPC) or to both National Classification and IPC Int.Cl. 5 D21F3/02		
II. FIELDS SEARCHED		
Minimum Documentation Searched ⁷		
Classification System	Classification Symbols	
Int.Cl. 5	D21F	
Documentation Searched other than Minimum Documentation to the Extent that such Documents are Included in the Fields Searched ⁸		
III. DOCUMENTS CONSIDERED TO BE RELEVANT⁹		
Category ¹⁰	Citation of Document, ¹¹ with indication, where appropriate, of the relevant passages ¹²	Relevant to Claim No. ¹³
X	EP,A,289477 (VALMET PAPER MACHINERY) 02 November 1988 see the whole document	1-7, 10, 11
A	---	12, 13, 17
X	GB,A,2199398 (SULZER-ESCHER WYSS) 06 July 1988 see the whole document	1-4, 7
A	---	1, 10-13, 17
A	DE,A,3515576 (VALMET OY) 28 November 1985 see the whole document	8, 15
A	EP,A,100895 (AHLSTRÖM OSAKEYHTIÖ) 22 February 1984 see the whole document	8, 15
A	US,A,3556940 (CRONIN) 19 January 1971 see the whole document	8, 15

	-/--	
¹⁰ Special categories of cited documents : <ul style="list-style-type: none"> "A" document defining the general state of the art which is not considered to be of particular relevance "E" earlier document but published on or after the international filing date "I" document which may throw doubts on priority claim(s) or which is cited to establish the publication date of another citation or other special reason (as specified) "O" document referring to an oral disclosure, use, exhibition or other means "P" document published prior to the international filing date but later than the priority date claimed "T" later document published after the international filing date or priority date and not in conflict with the application but cited to understand the principle or theory underlying the invention "X" document of particular relevance; the claimed invention cannot be considered novel or cannot be considered to involve an inventive step "Y" document of particular relevance; the claimed invention cannot be considered to involve an inventive step when the document is combined with one or more other such documents, such combination being obvious to a person skilled in the art. "&" document member of the same patent family 		
IV. CERTIFICATION		
Date of the Actual Completion of the International Search	Date of Mailing of this International Search Report	
05 DECEMBER 1990	19. 12. 90	
International Searching Authority	Signature of Authorized Officer	
EUROPEAN PATENT OFFICE	DE RIJCK F. 	

III. DOCUMENTS CONSIDERED TO BE RELEVANT (CONTINUED FROM THE SECOND SHEET)		
Category °	Citation of Document, with indication, where appropriate, of the relevant passages	Relevant to Claim No.
A	FR,A,2195723 (BELOIT) 08 March 1974 see the whole document ---	8, 15
A	GB,A,1059983 (HUYCK) 22 February 1967 see the whole document ---	9, 15

**ANNEX TO THE INTERNATIONAL SEARCH REPORT
ON INTERNATIONAL PATENT APPLICATION NO.**

US 9004773
SA 39646

This annex lists the patent family members relating to the patent documents cited in the above-mentioned international search report. The members are as contained in the European Patent Office EDP file on The European Patent Office is in no way liable for these particulars which are merely given for the purpose of information. 05/12/90

Patent document cited in search report	Publication date	Patent family member(s)	Publication date
EP-A-289477	02-11-88	JP-A- 1052897	28-02-89
GB-A-2199398	06-07-88	DE-A- 3705241 SE-A- 8705062	07-07-88 25-06-88
DE-A-3515576	28-11-85	SE-A- 8502533	26-11-85
EP-A-100895	22-02-84	DE-A- 3374704 JP-A, B, C 59076993 US-A- 4492611	07-01-88 02-05-84 08-01-85
US-A-3556940	19-01-71	None	
FR-A-2195723	08-03-74	US-A- 3840429 AU-A- 5858273 CA-A- 981955 DE-A, B, C 2338414 GB-A- 1426084 JP-A, B, C 49057105 NL-A- 7310813 SE-B- 389352	08-10-74 30-01-75 20-01-76 21-02-74 25-02-76 03-06-74 11-02-74 01-11-76
GB-A-1059983		None	