

C. W. GAY.

MACHINE FOR SURFACE FINISHING PAPER.

APPLICATION FILED AUG. 5, 1907.

4 SHEETS—SHEET 1.

Fig. 1.

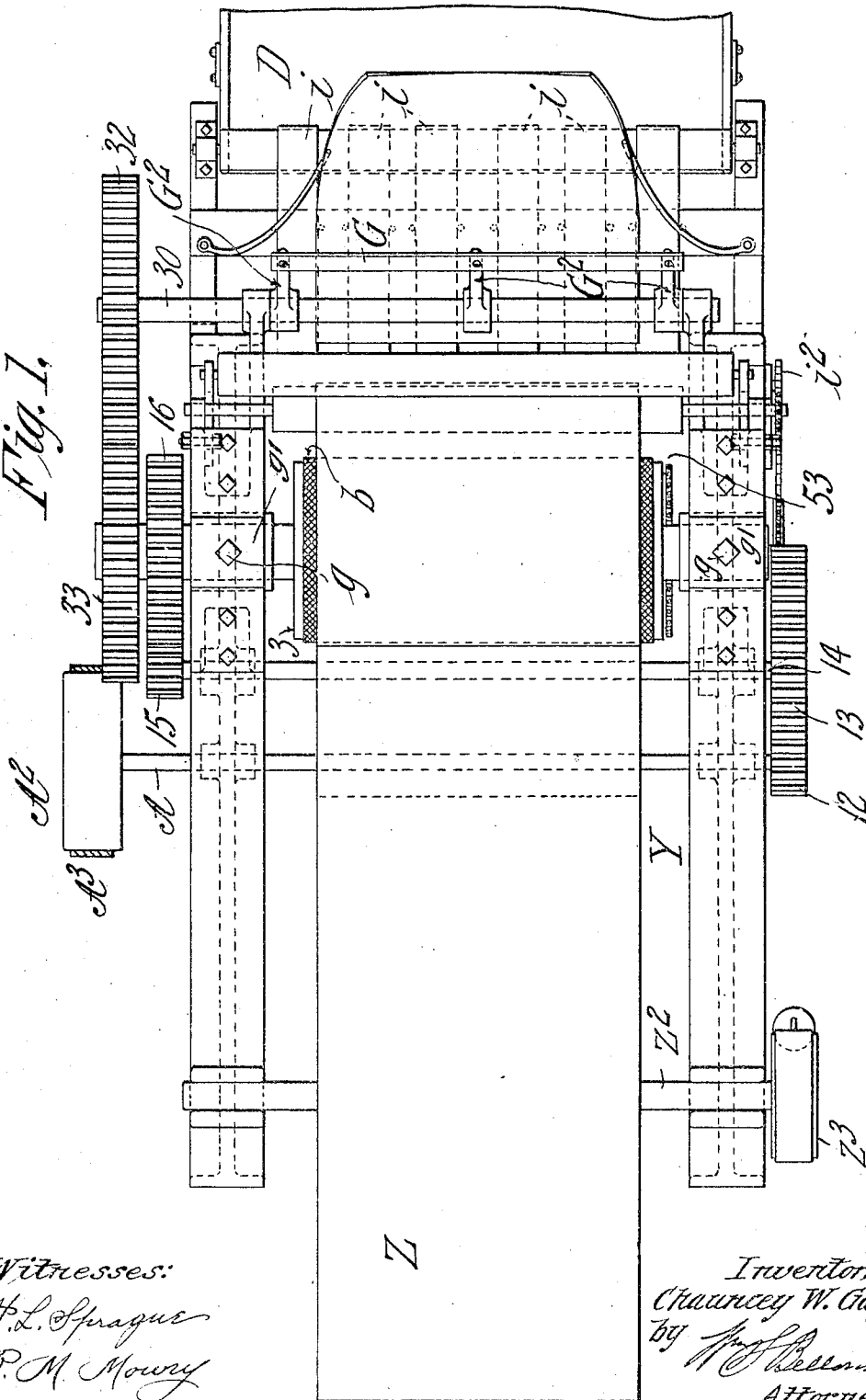

Witnesses:
H. L. Sprague
R. M. Mowry

Inventor:
Chauncey W. Gay.
by *[Signature]*
Attorney.

C. W. GAY.

MACHINE FOR SURFACE FINISHING PAPER.

APPLICATION FILED AUG. 5, 1907.

4 SHEETS—SHEET 2.

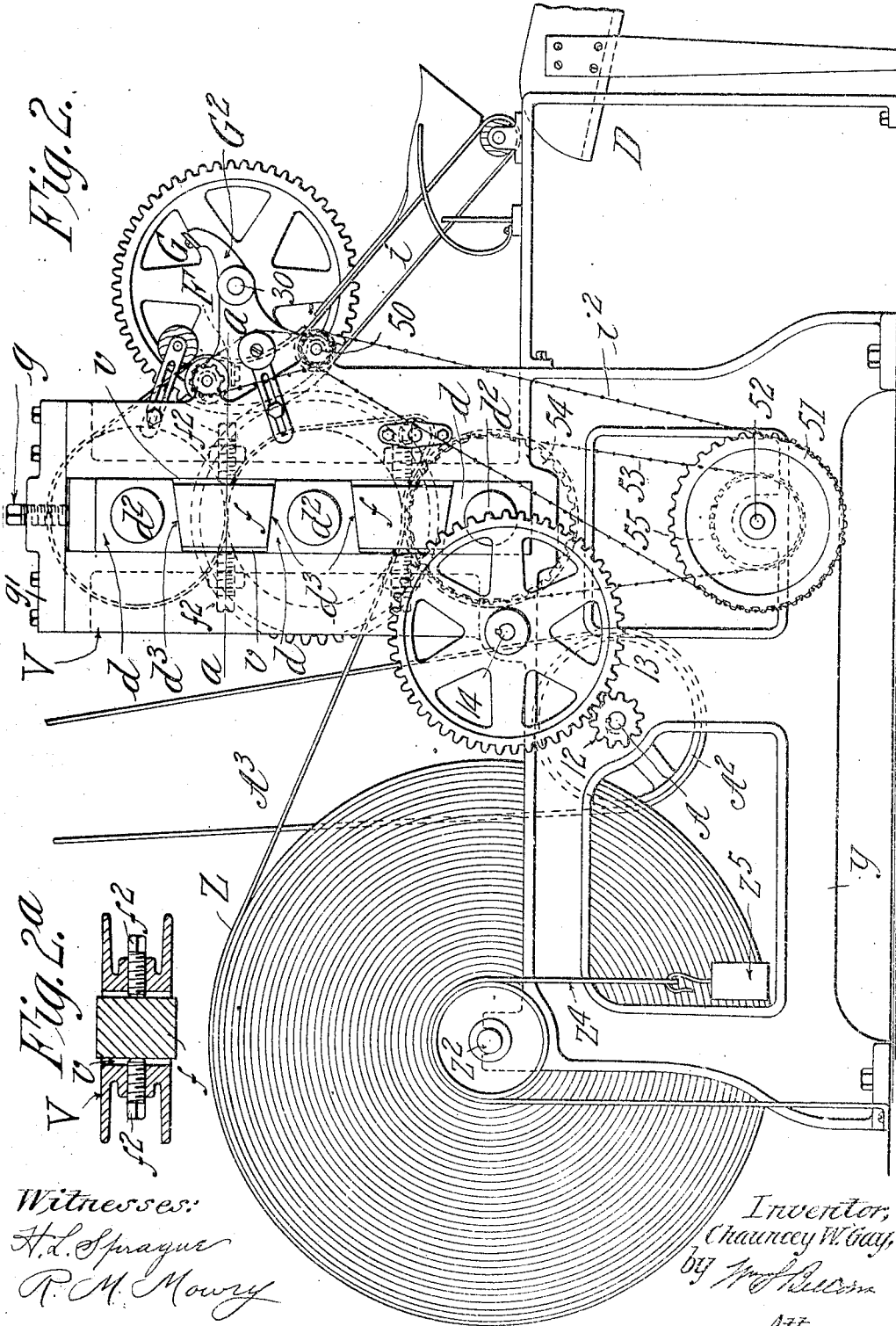

Fig. 2.

Fig. 2a.

Witnesses:
H. L. Sprague
R. M. Mowry

Inventor,
Chauncey W. Gay,
 by *W. H. ...*
 Attorney.

No. 887,622.

PATENTED MAY 12, 1908.

C. W. GAY.

MACHINE FOR SURFACE FINISHING PAPER.

APPLICATION FILED AUG. 5, 1907.

4 SHEETS—SHEET 3.

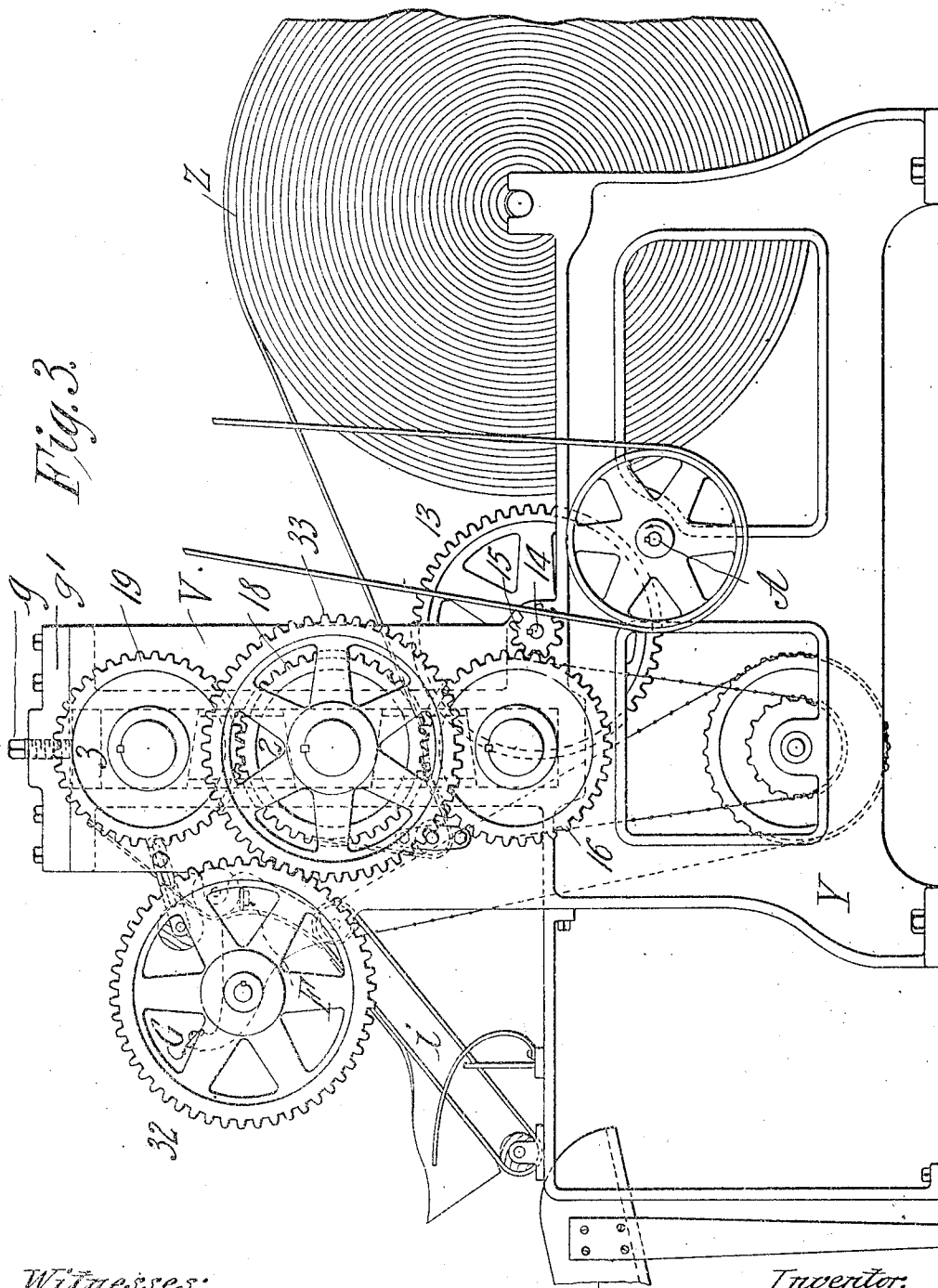

Fig. 3.

Witnesses:
H. L. Sprague
R. M. Mowry

Inventor,
Chauncey W. Gay,
by *H. Allen*
Attorney.

C. W. GAY.

MACHINE FOR SURFACE FINISHING PAPER.

APPLICATION FILED AUG. 5, 1907.

Fig. 6.

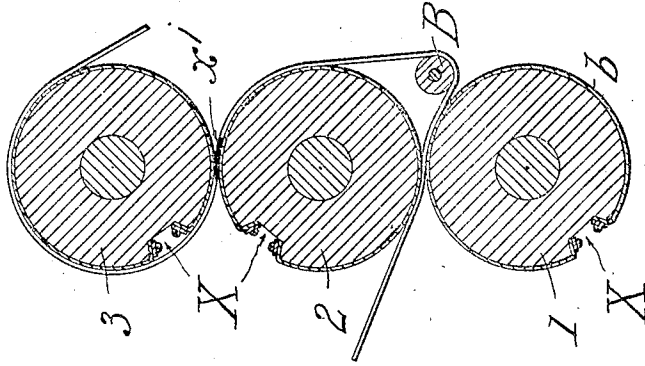

Fig. 5.

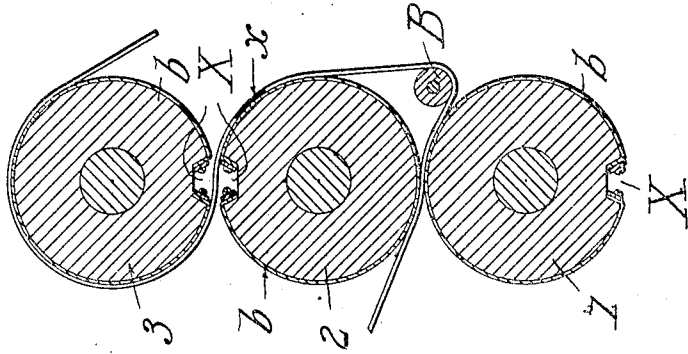
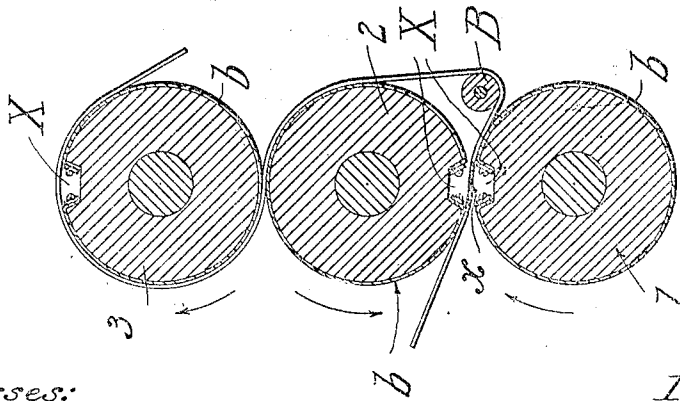

Fig. 4.



Witnesses:

H. L. Sprague
R. M. Mowry

Inventor,
Chauncey W. Gay,
 by *W. J. Bellows*
 Attorney.

UNITED STATES PATENT OFFICE

CHAUNCEY W. GAY, OF WEST SPRINGFIELD, MASSACHUSETTS

MACHINE FOR SURFACE-FINISHING PAPER.

No. 887,622

Specification of Letters Patent.

Patented May 12, 1908.

Application filed August 5, 1907. Serial No. 387,034.

To all whom it may concern:

Be it known that I, CHAUNCEY W. GAY, a citizen of the United States of America, and resident of West Springfield, in the county of Hampden and State of Massachusetts, have invented certain new and useful improvements in Machines for Surface - Finishing Paper, of which the following is a full, clear, and exact description.

My present invention has for its objects certain improvements to my prior patented machines, which patents are numbered 778,126 and 705,355. Among the more characteristic and salient features of said patented machines are co-acting, rotating, suitably covered cylinders or rolls, each carrying in a longitudinally-extending channel or depression an automatically-actuated gripper, one gripper seizing the leading end of the blank of paper and carrying it between the first and second cylinders, and another gripper taking the said leading end around for delivery at the forward end of the machine. While my said patented machines are efficacious and advantageous for the purposes designed, yet it has been found, in practice, that it is necessary that the paper operated upon by said patented machines should be fed in the form of sheets, and in proper time, and that the lengths of the sheets should not exceed something less than the circumference of the cylinder. Another objection to the structures of my prior patented machines is that the leading ends of the paper blanks taken by the grippers are not finished by the surfacing-cylinders, they are more or less mutilated by the grippers, and trimming off of each of the leading ends, say one-half to one inch, is necessitated, consuming time, labor, and stock.

One of the leading objects, therefore, of my invention is to do away with the grippers and the necessity for their use, and so to construct and combine the elements of my present invention that the paper to be operated upon may be fed from a supply-roll in one long, continuous sheet, and, also, that every portion of the paper operated upon may be utilized,—every part of the paper being given the desired finish in verisimilitude of cloth,—no mutilations occurring, with consequent loss of time, labor, and money, in trimming.

With this most important object in view particularly, and with other minor objects of improvement which will appear as the specification proceeds and the invention, as a whole, is more fully and completely disclosed,

the invention consists in the novel construction, combination, and arrangement of parts as fully hereinafter set forth in the specification, summed up in the claims, and illustrated in the drawings, in which latter:

Figure 1 is a plan view of the machine constituting my present invention; Fig. 2 is a view in the nature of a side elevation; Fig. 2^a is a detail view of an adjusting mechanism, more clearly illustrating the same parts shown in dotted lines elsewhere; Fig. 3 is a view similar to Fig. 2, but looking at the machine from the opposite side; and Figs. 4, 5, and 6 are detail sectional views of the three-high rolls or cylinders, with the paper therebetween, showing graphically the operation upon the paper at different points in the revolution of the cylinders.

Now, referring in detail to the drawings, Y represents a frame for the working parts of my machine, and which, among other parts, supports, in appropriate bearings therein, a supply-roll Z of paper, to be operated upon, which roll is wound upon a journal-shaft z², over which passes a strap, or the like, z¹, one end thereof being secured against movement and the other end carrying a weight z³, whereby proper tensioning of the supply-roll is effected. While other means of tensioning may be used, I have devised the form disclosed as being particularly effective for the purpose intended. Also mounted in suitable bearings in the frame are, as disclosed in the drawings, a set of three-high rolls or cylinders, 1, 2, 3 (most clearly shown in Figs. 4, 5, and 6); but it is to be understood that this is merely for the sake of illustration,—in fact, in practice, I preferably use a set of six-high rolls or cylinders (a set additional to and identical with the set shown in the drawings being superposed upon the set so shown). I have found it desirable, by demonstrations in practical use, to have the set of three-high rolls shown, numbered 1, 2, and 3, peripherally covered with cloth, and to have the remaining set of three-high rolls (not shown) covered with cloth overlaid with thin sheet copper.

The radius of each cylinder or roll, 1, 2, 3, is broken by a longitudinally - extending channel or depression X, in which the two ends of the cloth-covering are suitably secured, these channels being a feature common also to my patented structures; but it may be here stated that the function of the

channels is to avoid a seam in the paper after it shall have been operated upon; because a seam line is unavoidable unless the ends of the cloth are carried down beneath the peripheries of the cylinders (as shown) and secured in such depressions; and this sinking of the ends of the cloth have met and overcome a long-felt difficulty.

The cylinders (see Figs. 2 and 2^a) are each supported, at either end, in a bearing-block *d*, mounted in a slot *v* in a standard *V* of the frame *Y* of the machine; the upper one of said blocks *d* having a desirably flat top and an inclined or beveled base *d*³, the middle block having both an inclined top and an inclined base, the two inclines converging, and the lowermost block having an inclined top and a flat base.

Between each two adjacent blocks *d* is disposed a wedge block *f* of lesser width than the slot *v* and the blocks *d*, as shown clearly in the drawings.

Passing transversely through the sides of the standard *V* are threaded adjusting-screws *f*² (shown in dotted lines in Fig. 2 and in full lines in Fig. 2^a) bearing against the wedges *f*; whereby the wedges may be driven horizontally either to the right or to the left, causing consequent vertical movement of the blocks *d*, for properly positioning the axis of one roll or cylinder relatively to the axis of the adjacent roll, according to the thickness of the paper to be operated upon, or to the degree of pressure to which the paper is to be subjected. It will be observed, also, that the blocks *d*, co-acting with the wedges *f*, prevent the rolls or cylinders collapsing or settling together, when the longitudinally-extending channels or depressions *X* of two adjacent rolls come into register.

Passing through the cap piece *g* of each of the slotted standards *V* is a threaded set-screw *g*, bearing against the top of the upper block *d*, and assisting in regulating the pressure of the collective rolls or cylinders.

The mechanism for operating the rolls comprises a driving-shaft *A* carrying at one end a pinion 12 meshing with a spur gear wheel 13 carried by a countershaft 14, which carries at its opposite end a pinion 15, meshing with a spur gear wheel 16 on the extended journal of the lower cloth-covered cylinder 1.

The cylinder 2 is provided with a spur gear wheel 18 meshing with a spur gear wheel 16; and cylinder 3 has a spur gear wheel 19 meshing with a spur gear wheel 18, whereby all three cylinders rotate at uniform speed in the directions of the arrows, Fig. 4.

Now, I come to one of the leading features of my present invention, and one which goes far to make up the general excellence and practicability of my improved machine, and attention is here invited to Figs. 4, 5, and 6: It will be readily seen that the paper in passing between the rolls 1 and 2, of equal size,

would have a cross-stripe therein at the point marked *x*, or where two longitudinally-extending channels *X* register, and which would not be subjected to the finishing action of the cloth-coverings *b* of the rolls 1, 2 and 3, were not some means invented to remedy this difficulty. The result accomplished by the means now to be disclosed has been sought after for many years by inventors, and I have long labored to discover a thoroughly practical method. In the same horizontal plane, or approximately the same plane, as a line drawn horizontally between the rolls 1 and 2, is a roller *B* supported in suitable bearings, over which passes the paper as it comes from between rolls 1 and 2. Wherefore, it will be noted that, by the provision of the rollers *B*, the sheet of paper is caused to take a detour, as it were, whereby the portion *x* of the paper, which has not been subjected to the action of rolls 1 and 2, because of the registering position, there, of the channels *X*, is caused to take an extended travel, so that, instead of arriving at the registering position of the channels *X* in rolls 2 and 3 (as it otherwise would, were the roller *B* not provided), it is brought to a position to pass between unrecessed or unchanneled peripheral portions of rolls 2 and 3, as indicated most graphically at the point *x'*, Fig. 6. Briefly, the result accomplished is that the portion of the paper-sheet which is not cloth-surfaced in its passage between rolls 1 and 2, is subjected to the surfacing action between rolls 2 and 3, making the entire surface, throughout the entire length, of the paper, absolutely uniform.

When the rolls 2 and 3 are in the position shown in Fig. 4, with the channeled portions *X* of rolls 1 and 2 registering, the paper is loose from the nipping or biting point between rolls 2 and 3 clear back to the tensioned supply-roll *Z*, whereby the paper may be stretched, or have any wrinkles (which are apt to form where the first two rolls loosen their hold on the sheet) taken out. This feature, also, is of importance, as contributing to the general reliability of the machine for doing perfect work.

For carrying the paper sheet forward onto a receiving table or chute *D*, common feeding-tapes, or the like, *i*, *i*, may advantageously be utilized, and are desirably driven by a sprocket-chain *i*² running around a sprocket on the end of the tape pulley shaft 50 and also around a sprocket-wheel 51 on a shaft 52, which is driven by a chain 53 running around a sprocket-wheel 54 on one end of cylinder 1 and around another sprocket-wheel 55 on said shaft 52.

For cutting off the sheets which are laid on the receiving table *D* a shear device is utilized, *F* representing a stationary shear-blade, and *G* a revoluble blade carried by arms *G*² extending from a shaft 30 driven by

a spur-gear 32 in mesh with a spur gear 33 on an extended journal of the cloth-covered cylinder 2.

5 It will be understood that the set of three-high rolls or cylinders, previously mentioned as not being shown in the drawings, but which are superposed upon the set of rolls 1, 2 and 3, are identical with said rolls 1, 2, and 3, even to the provision of a roller B, acting in conjunction therewith.

10 It is obvious that my invention, in its minor details, is susceptible of slight changes; and all such immaterial changes, not affecting the spirit of my invention, come strictly within the scope and purview thereof.

15 As the present machine is designed, and as the same has been described, the rolls or cloth surfacing cylinders are in vertical stacked arrangement, and their journals, journal boxes, and the wedge shaped distancing blocks are in vertical alignment, but obviously inversions or other arrangements of the essential or desirable operative parts may be made in a manifest manner,—the machine may, or may not, have the cutting off shear and sheet delivering means shown, the surface finished paper may be run in a continuous web onto a take-up roll therefor and thereafter handled in any desirable manner, or the machine may be combined as an entirety with other machinery for paper manufacture.

25 While this machine is possessed of fully, or more than double the operative capability of my heretofore patented cloth finishing machines and is operative by the requirement of less tending, and without waste of stock, it has a large number of times greater cloth finishing capacity than the ordinary plating machines which can only be operated by the exercise of much hand labor, preparation and constant attendance.

I claim:—

45 1. In a machine for surface-finishing paper, a set of rolls having portions thereof reduced along longitudinal lines provided with peripherally surface finishing coverings, terminating within said reduced portions, and disposed with their peripheries in proximity, and means for extending the course of travel of the paper to be operated upon after its passage between the first rolls of the set.

50 2. In a machine for surface-finishing paper a set of at least three rolls each peripherally covered with finishing sheet material disposed with their peripheries in proximity, and each having a longitudinally extending depression therein, and means for preventing the presentation to the registering depressions of the second and third rolls of the set of the portion of the paper that is passed between the depressions of the first and second rolls of the set.

65 3. In a machine for surface-finishing paper, a set of at least three rolls having their

peripheries in proximity, and peripherally covered with a finishing sheet material, the continuity of which is interrupted on lines longitudinally of the rolls, and a roll disposed in proximity to two of said rolls and around which the material, operated upon by the first two of the rolls, passes before entering to the action of the second and third rolls of the set.

70 4. In a machine for surface finishing paper, a set of at least three axially parallel rolls, of uniform diameters peripherally covered with a finishing sheet material, disposed with their peripheries in proximity, each having a reduced portion extending longitudinally of the roll, a shaft for carrying a supply roll of paper to be operated upon, teasing means for said shaft, and a roller disposed in proximity to two of the surface finishing rolls and over which the material operated upon by two of the rolls passes with a detour course before moving between succeeding rolls of the set.

75 5. In a machine for surface finishing paper, the combination with a machine frame having opposite vertically slotted uprights, a set of at least three rolls peripherally covered with a finishing sheet material, arranged axially parallel one above another, having end journals, and having reduced portions extending along longitudinal lines within which the said roll covers terminate, of separated journal blocks fitted in said vertical slots and in which said end journals are mounted, having their proximate faces inclined towards each other, wedge shaped blocks, narrower than said slots and located therewithin, and having bearings by their beveled sides against the inclined sides of the journal blocks, and means for transversely moving said wedge shaped blocks.

80 6. In a machine of the character described, the combination with a machine frame having oppositely vertically slotted uprights, a series of rolls peripherally covered with a finishing sheet material arranged axially parallel, having end journals and having reduced portions extending longitudinally and within which edge portions of the roll covers are disposed, of separated journal blocks, fitted in said vertical slot, and in which said end journals are mounted, having their proximate faces inclined towards each other, wedge shaped blocks narrower than said slots and located therewithin between pairs of said journal blocks and bearing by their beveled sides against the latter, and a pair of oppositely located screws for each of said wedge shaped blocks having thread engagements through the portions of the said uprights which form an opposite wall of said slot, and end-wise engaging the block.

85 7. In a machine of the character described, the combination with a machine frame having opposite vertically slotted uprights pro-

70

75

80

85

90

95

100

105

110

115

120

125

130

vided with cap pieces, a series of rolls periph-
 erally covered with finishing sheet material
 arranged axially parallel, having longitudi-
 nal depressions in the sides thereof within
 5 which the edges of the covering material are
 disposed and secured, and having end jour-
 nals, of separated journal box blocks fitted in
 said vertical slots and in which said end jour-
 nals are mounted, having their proximate
 10 faces inclined towards each other, wedge
 shaped blocks, narrower than said slots, lo-
 cated therewithin and having upper and

lower face bearings against the inclined sur-
 faces of the relatively contiguous journal
 blocks, and a screw passed vertically with a
 thread engagement through each said cap
 piece and operative to regulate the pressure
 exerted by one roll in relation to the next. 15

Signed by me at Springfield, Mass., in pres-
 ence of two subscribing witnesses.

CHAUNCEY W. GAY.

Witnesses:

MARGARET PLAYDON,
 M. E. FOLEY.