

K. THIELE.
RECOIL GUN.

APPLICATION FILED AUG. 13, 1908.

Patented Feb. 9, 1909.

2 SHEETS—SHEET 1.

911,849.

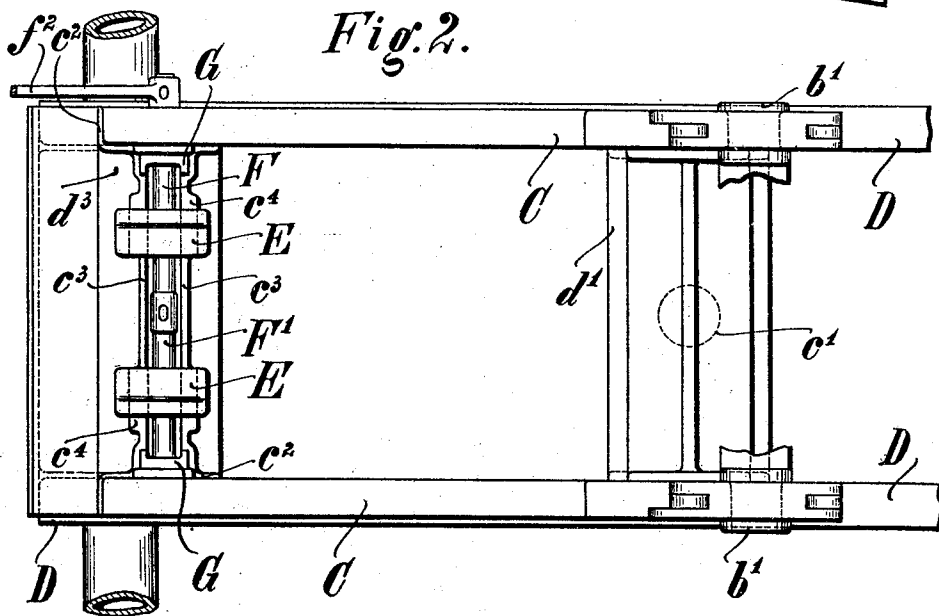
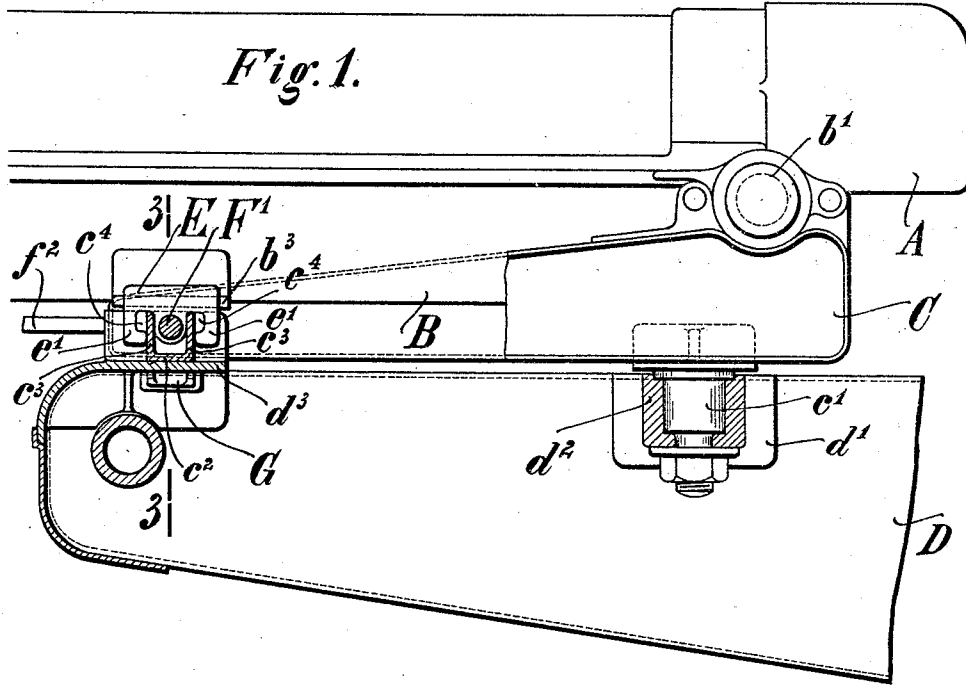

Witnesses
J. M. Waples
Edw. S. Stanley.

Inventor
Karl Thiele
By Knight Bros
attys

K. THIELE.
RECOIL GUN.

APPLICATION FILED AUG. 13, 1908.

911,849.

Patented Feb. 9, 1909.

2 SHEETS—SHEET 2.

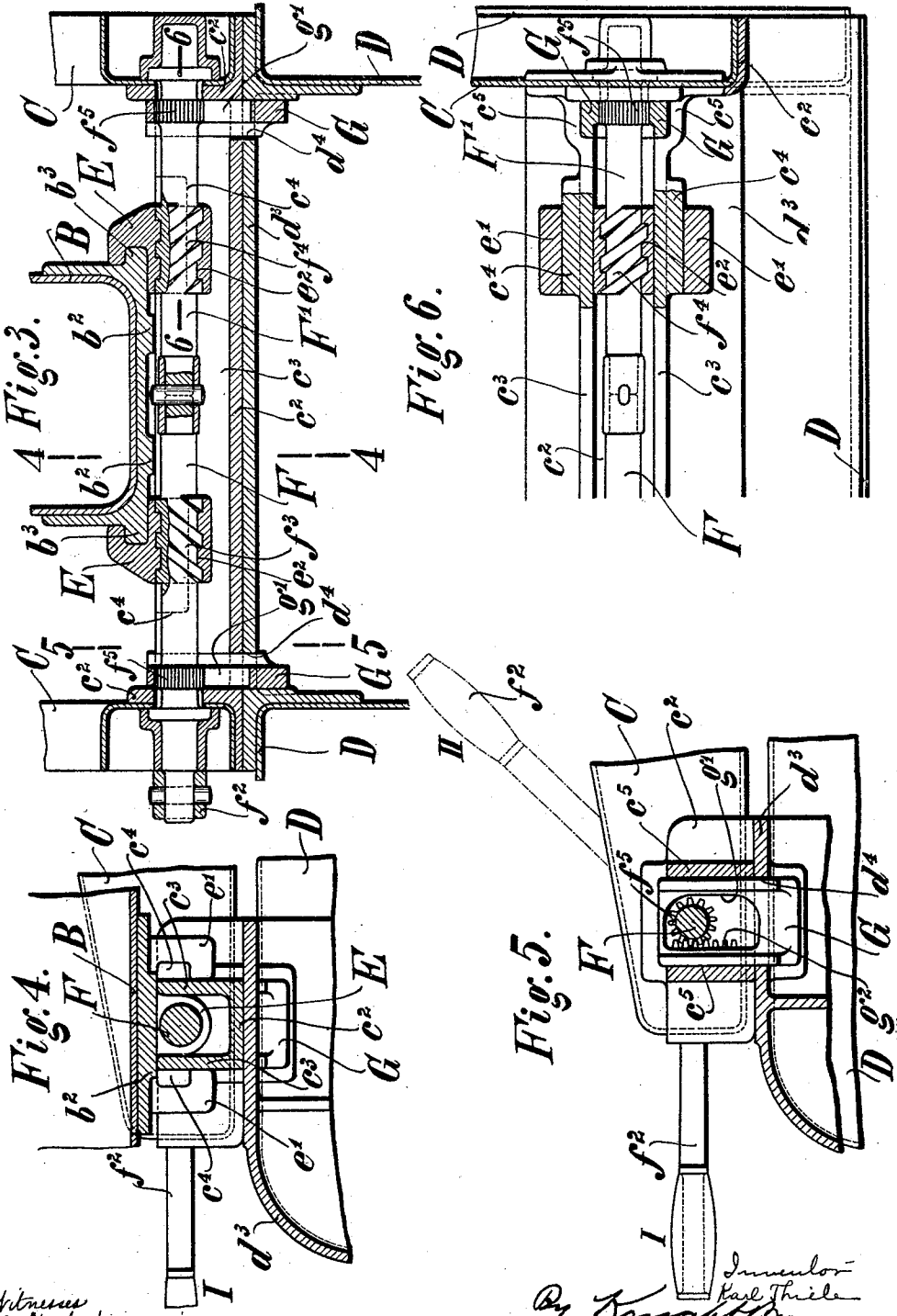

Witness
J. M. Winkler
Edw. J. Stanley

Inventor
Karl Thiele
By
Knight

UNITED STATES PATENT OFFICE.

KARL THIELE, OF BORBECK, NEAR ESSEN-ON-THE-RUHR, GERMANY, ASSIGNOR TO FRIED. KRUPP AKTIENGESELLSCHAFT, OF ESSEN-ON-THE-RUHR, GERMANY.

RECOIL-GUN.

No. 911,849.

Specification of Letters Patent.

Patented Feb. 9, 1909.

Application filed August 13, 1908. Serial No. 448,355.

To all whom it may concern:

Be it known that I, KARL THIELE, a subject of the Emperor of Germany, and a resident of Borbeck, near Essen-on-the-Ruhr, Germany, have invented certain new and useful Improvements in Recoil-Guns, of which the following is a specification.

The present invention relates to the type of recoil guns having an elevating mechanism and a horizontal training mechanism and an upper carriage which is mounted to swing relatively to a mount and the object of the invention is to provide such guns with a choking device. In accordance with the present invention this object is attained by connecting the slide-track to the upper carriage and the upper carriage to the mount by means of clutch devices relieving the elevating and the training mechanism.

The accompanying drawings show, by way of example, one embodiment of those parts of the gun to which the invention relates.

Figure 1 is a side view, partly in section; Fig. 2 is a top view, some parts being left out; Fig. 3 is a section, on an enlarged scale, on line 3—3, Fig. 1, looking from the left; Fig. 4 is a section on line 4—4, Fig. 3, looking from the right; Fig. 5 is a section on line 5—5, Fig. 3, looking from the right, and Fig. 6 is a top view of Fig. 3, partly in section on line 6—6, Fig. 3.

The gun barrel A (Fig. 1) is mounted to slide on the slide-track carrier B (Figs. 1, 3 and 4) which has its rear end provided with the horizontal trunnions b^1 . The slide-track carrier B is swingingly mounted in an upper carriage C through the medium of the horizontal trunnions b^1 . The upper carriage C rests on a mount D and can be swung about a vertical axis relatively to the mount. To that end the upper carriage C is provided with a vertical trunnion c^1 (see especially Fig. 1) for which a bearing d^2 is provided in a transverse support d^1 of the mount D. The front end of the upper carriage C rests on a transverse support d^3 of the mount D and is connected thereto in such a manner that the upper carriage is secured against being lifted off the mount. The means provided for this purpose are not shown in the drawings as they may be of any suitable known construction. A horizontal training mechanism (not shown in the drawings), which is inserted between the upper car-

riage C and the mount D, serves for swinging the upper carriage about the axis of the vertical trunnion c^1 . Furthermore an elevating mechanism (not shown) is inserted between the upper carriage C and the slide-track carrier B and serves for swinging the slide-track carrier about the axis of the horizontal trunnions b^1 . The horizontal training mechanism and the elevating mechanism may be of any suitable known construction.

The slide-track carrier carries on its under side two press-pieces b^2 (Figs. 3 and 4) which are arranged in such a manner that they rest on legs c^3 of a transverse carrier c^2 of the upper carriage C when the slide-track carrier is in the choking position shown in the drawing. Two claws E are guided parallel to the axis of the trunnions b^1 on rails c^4 of the legs c^3 through the medium of L-shaped projections e^1 (see especially Fig. 1). The claws E are capable of engaging laterally over rails b^3 on the slide-track carrier B, in the manner shown in Fig. 3, when the slide-track carrier rests with the press-pieces b^2 on the legs c^3 of the transverse carrier c^2 . A shaft, which consists of two rigidly connected parts F and F^1 and which can be turned by means of a handle f^2 , is non-slidably mounted in the side walls of the upper carriage C. The shaft F F^1 has two parts f^3 and f^4 provided with screw-threads (Figs. 3 and 6). One of the parts has left-hand threads and the other part has right-hand threads. The parts f^3 and f^4 engage in corresponding internal threads e^2 (Figs. 3 and 6) in the two claws E. By reason of this arrangement the claws E must move either towards or from each other when the lever f^2 is turned. The lever f^2 can be secured in the position shown in full lines in Figs. 4 and 5 and in the position shown in dotted lines in Fig. 5. In the following the position shown in full lines will be termed position I and the position shown in dotted lines will be termed position II. The relative arrangement of the parts is selected in such a manner that, when the lever f^2 is in position II, the claws E assume such a position that they are located outside of the path of movement of the rails b^3 of the slide-track carrier B, while, when the lever f^2 is in position I, the claws E assume the position in which they engage over the rails b^3 of the slide-track carrier B when at the same time the slide-track carrier rests with the

press-pieces b^2 on the legs c^3 of the transverse carrier c^2 .

At its outer ends the transverse carrier c^2 is provided with guides c^5 (Figs. 5 and 6) for two bolts G which are capable of sliding movement parallel to the axis of the trunnion c^1 . The transverse carrier d^3 of the mount is provided with notches d^4 (Figs. 3 and 5) into which the bolts G can enter without play when the upper carriage C is in its central position, that is its chocking position. The bolts G are provided with openings g^1 (Figs. 3 and 5) through which the shaft F F^1 passes. The parts of the shaft F F^1 which are located within the openings g^1 are provided with teeth f^5 which mesh with teeth g^2 (Fig. 5) on the bolts G. The arrangement is selected in such a manner that, when the lever f^2 is in position I, the bolts G engage in the notches d^4 of the mount D, when at the same time the upper carriage C is in the chocking position, while the bolts G are out of engagement with the notches d^4 when the lever f^2 is in position II. When the chocking device is out of use the lever f^2 is secured in position II. In this position of the lever f^2 the claws E are located outside of the path of movement of the rails b^3 of the slide-track carrier B, and the necessary elevation can therefore be imparted, without any hindrance, to the gun-barrel through the medium of the elevating mechanism. Furthermore the bolts G are out of engagement with the notches d^4 in the mount and the upper carriage C can therefore be swung freely about the axis of the trunnion c^1 through the medium of the horizontal training mechanism.

When the parts of the gun, which are adjustable through the medium of the horizontal training mechanism and the elevating mechanism, are to be secured in the chocking position the muzzle of the gun-barrel is first, through the medium of the elevating mechanism, lowered to such an extent that the slide-track carrier B rests with the press-pieces b^2 on the legs c^3 of the transverse carrier c^2 of the upper carriage C. If necessary the upper carriage C is furthermore brought into its central position by means of the lateral training mechanism. Thereupon the lever f^2 is shifted from position II to position I and is secured in the latter position. When the lever is shifted the threads on the parts f^3 and f^4 of the shaft F F^1 cause the claws E to move so far upwardly that they engage over the rails b^3 of the slide-track carrier B; simultaneously herewith the toothed gear f^5 g^2 causes the bolts G to enter the notches d^4 in the mount. In this position of the parts the slide-track carrier B is secured in position relatively to the upper carriage C independently of the elevating mechanism, that is the slide-track carrier is chocked. Downwardly and up-

wardly directed shocks which act on the slide-track carrier B, for instance during the travel, are then absorbed by the transverse carrier c^2 of the upper carriage C through the medium of the press-pieces b^2 and the claws E. The elevating mechanism is therefore entirely relieved. Shocks which act in lateral direction on the slide-track carrier B are also transmitted by the claws E to the upper carriage C. Shocks which act in lateral direction on the upper carriage C are transmitted directly to the mount D by the bolts G, and the horizontal training mechanism is therefore also relieved.

Having thus described the invention, what is claimed and desired to be secured by Letters Patent is:

1. A recoil gun having a mount, an upper carriage mounted to swing relatively to the mount, a slide-track carrier mounted to swing relatively to the upper carriage, a training mechanism, an elevating mechanism, means for coupling the slide-track carrier to the upper carriage, and means for coupling the upper carriage to the mount.

2. A recoil gun having a mount, an upper carriage mounted to swing relatively to the mount, a slide-track carrier mounted to swing relatively to the upper carriage, means for coupling the slide-track carrier to the upper carriage, means for coupling the upper carriage to the mount, and a common operating member for both of said coupling means.

3. A recoil gun having a mount, an upper carriage swingingly mounted on the mount, a slide-track carrier swingingly mounted on the upper carriage, a training mechanism, an elevating mechanism, and means for coupling the mount, the upper carriage and the slide-track carrier together.

4. A recoil gun having a mount, an upper carriage mounted to swing on the mount, a slide-track carrier mounted to swing on the upper carriage, means for coupling the slide-track carrier to the upper carriage, and means for coupling the upper carriage to the mount; said first-named means comprising a pair of slidingly mounted claws carried by the upper carriage, and means for moving said claws into engagement with the slide-track carrier.

5. A recoil gun having a mount, an upper carriage mounted to swing on the mount, a slide-track carrier mounted to swing on the upper carriage, means for coupling the slide-track carrier to the upper carriage, and means for coupling the upper carriage to the mount; said first-named means comprising a pair of slidingly mounted members carried by the upper carriage and arranged one to each side of the slide-track carrier, and means for simultaneously moving said members into engagement with the slide-track carrier.

6. A recoil gun having a mount, an upper carriage mounted to swing on the mount, a slide-track carrier mounted to swing on the upper carriage, means for coupling the slide-track carrier to the upper carriage, and means for coupling the upper carriage to the mount; said last-named means comprising notches in the mount, sliding bolts in the upper carriage, and means for moving the bolts into engagement with the notches.

7. A recoil gun having a mount provided with notches, an upper carriage mounted to swing on the mount, a slide-track carrier mounted to swing on the upper carriage, claws slidingly mounted on the upper carriage and adapted to engage the slide-track

carrier to couple the upper carriage to the slide-track carrier, bolts slidingly mounted in the upper carriage and adapted to enter the notches in the mount to couple the upper carriage to the mount, an operating shaft mounted in the upper carriage, a gear positively connecting the shaft to the claws, and a gear positively connecting the shaft to the bolts.

The foregoing specification signed at Dusseldorf, Germany, this 17th day of July, 1908.

KARL THIELE. [L. s.]

In presence of—

WM. WASHINGTON BRUNSWICK,
OTTO KÖNIG.