



- (51) International Patent Classification:
H01R 24/38 (2011.01) *H01R 9/05* (2006.01)
- (21) International Application Number:
PCT/US2015/049355
- (22) International Filing Date:
10 September 2015 (10.09.2015)
- (25) Filing Language: English
- (26) Publication Language: English
- (30) Priority Data:
62/049,160 11 September 2014 (11.09.2014) US
- (71) Applicant: **COMMSCOPE TECHNOLOGIES LLC**
[US/US]; 1100 CommScope Place, SE, Hickory, North Carolina 28602 (US).
- (72) Inventor: **HARWATH, Frank A.**; 2420 Cloverdale Rd, Naperville, Illinois 60564 (US).
- (74) Agent: **CANNON, James, R.**; Myers Bigel Sibley & Sajovec, P.A., P.O. Box 37428, Raleigh, North Carolina 27627 (US).

- (81) Designated States (unless otherwise indicated, for every kind of national protection available): AE, AG, AL, AM, AO, AT, AU, AZ, BA, BB, BG, BH, BN, BR, BW, BY, BZ, CA, CH, CL, CN, CO, CR, CU, CZ, DE, DK, DM, DO, DZ, EC, EE, EG, ES, FI, GB, GD, GE, GH, GM, GT, HN, HR, HU, ID, IL, IN, IR, IS, JP, KE, KG, KN, KP, KR, KZ, LA, LC, LK, LR, LS, LU, LY, MA, MD, ME, MG, MK, MN, MW, MX, MY, MZ, NA, NG, NI, NO, NZ, OM, PA, PE, PG, PH, PL, PT, QA, RO, RS, RU, RW, SA, SC, SD, SE, SG, SK, SL, SM, ST, SV, SY, TH, TJ, TM, TN, TR, TT, TZ, UA, UG, US, UZ, VC, VN, ZA, ZM, ZW.
- (84) Designated States (unless otherwise indicated, for every kind of regional protection available): ARIPO (BW, GH, GM, KE, LR, LS, MW, MZ, NA, RW, SD, SL, ST, SZ, TZ, UG, ZM, ZW), Eurasian (AM, AZ, BY, KG, KZ, RU, TJ, TM), European (AL, AT, BE, BG, CH, CY, CZ, DE, DK, EE, ES, FI, FR, GB, GR, HR, HU, IE, IS, IT, LT, LU, LV, MC, MK, MT, NL, NO, PL, PT, RO, RS, SE, SI, SK, SM, TR), OAPI (BF, BJ, CF, CG, CI, CM, GA, GN, GQ, GW, KM, ML, MR, NE, SN, TD, TG).

Published:

— with international search report (Art. 21(3))

(54) Title: COAXIAL CABLE AND CONNECTOR ASSEMBLY

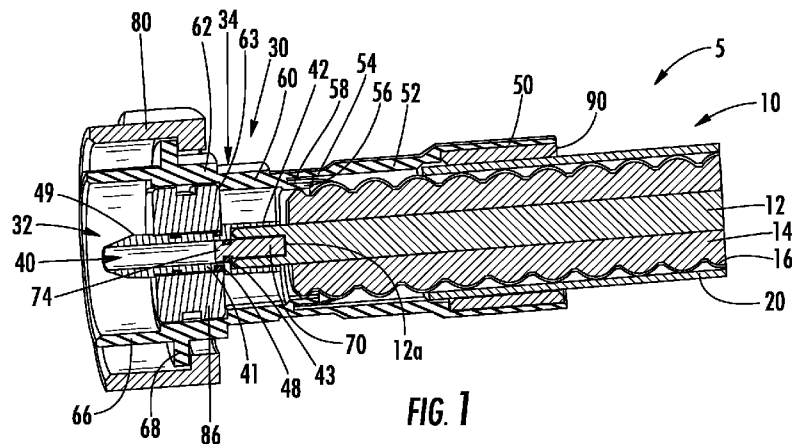

(57) Abstract: A coaxial cable-connector assembly includes a coaxial cable and a coaxial connector. The coaxial cable includes: an inner conductor having a termination end, the termination end including a bore; a dielectric layer that overlies the inner conductor; an outer conductor that overlies the dielectric layer having a termination end; and a jacket that overlies the outer conductor. The coaxial connector includes: an inner conductor body including a boss that encircles the termination end of the inner conductor and a longitudinal bore; an outer conductor body electrically connected with the termination end of the outer conductor; and an expansion member inserted into the bore of the termination end of the inner conductor, the expansion member being sized and configured to radially expand the termination end of the inner conductor into electrical contact with the boss of the inner conductor body.

WO 2016/040578 A1

COAXIAL CABLE AND CONNECTOR ASSEMBLY

Related Application

[0001] The present application claims priority from and the benefit of U.S. Provisional Patent Application No. 62/049,160, filed September 11, 2014, the disclosure of which is hereby incorporated herein in its entirety.

Field of the Invention

[0002] The present invention is directed generally to electrical cable connectors, and more particularly to coaxial connectors for electrical cable.

Background of the Invention

[0003] Coaxial cables are commonly utilized in RF communications systems. A typical coaxial cable includes an inner conductor, an outer conductor, a dielectric layer that separates the inner and outer conductors, and a jacket that covers the outer conductor. Coaxial cable connectors may be applied to terminate coaxial cables, for example, in communication systems requiring a high level of precision and reliability.

[0004] Coaxial connector interfaces provide a connect/disconnect functionality between (a) a cable terminated with a connector having a particular connector interface and (b) a corresponding connector with a mating connector interface mounted on an apparatus (such as an antenna or remote radio head) or on another cable. Typically, one connector will include a structure such as a pin or post connected to an inner conductor and an outer conductor connector body connected to the outer conductor; these are mated with a mating sleeve (for the pin or post of the inner conductor) and another outer conductor connector body of a second connector that fits within or over the outer conductor body of the first connector. Coaxial connector interfaces often utilize a threaded coupling nut or other retainer that draws

the connector interface pair into secure electro-mechanical engagement when the coupling nut (which is captured by one of the connectors) is threaded onto the other connector.

[0005] Passive Intermodulation Distortion (PIM) is a form of electrical interference/signal transmission degradation that may occur with less than symmetrical interconnections and/or as electro-mechanical interconnections shift or degrade over time. Interconnections may shift due to mechanical stress, vibration, thermal cycling, and/or material degradation. PIM can be an important interconnection quality characteristic, as PIM generated by a single low quality interconnection may degrade the electrical performance of an entire RF system. Thus, the reduction of PIM via connector design is typically desirable.

[0006] It may be desirable to provide alternative techniques for attaching connectors to cable conductors that enjoy low PIM and relatively low labor manufacturing.

Summary

[0007] As a first aspect, embodiments of the invention are directed to a coaxial cable-connector assembly. The assembly comprises a coaxial cable and a coaxial connector. The coaxial cable comprises: an inner conductor having a termination end, the termination end including a bore; a dielectric layer that overlies the inner conductor; an outer conductor that overlies the dielectric layer having a termination end; and a jacket that overlies the outer conductor. The coaxial connector comprises: an inner conductor body configured to mate with the inner conductor body of a mating coaxial cable jack, the inner conductor body including a boss that encircles the termination end of the inner conductor, and further including a longitudinal bore; an outer conductor body configured to mate with the outer conductor body of the mating coaxial cable jack, the outer conductor body being electrically connected with the termination end of the outer conductor; and an expansion member inserted into the bore of the termination end of the inner conductor, the expansion member being sized and configured to radially expand the termination end of the inner conductor into electrical contact with the boss of the inner conductor body.

[0008] As a second aspect, embodiments of the invention are directed to a coaxial connector comprising: an inner conductor body configured to mate with the inner conductor body of a mating coaxial cable jack, the inner conductor body further configured to be attached to a termination end of an inner conductor of a coaxial cable; and an outer conductor body configured to mate with the outer conductor body of the mating coaxial cable jack, the outer conductor body further configured to be electrically connected with a termination end of an outer conductor of the coaxial cable. The outer conductor body further includes a

radially inward lip, such that a gap is formed between the lip and an inner surface of the outer conductor body, and is configured to receive the termination end of the outer conductor of the cable resides within the gap. The outer conductor body is configured to be crimped to the termination end of the outer conductor of the cable.

[0009] As a third aspect, embodiments of the invention are directed to a coaxial cable-connector assembly, comprising a coaxial cable and a coaxial connector. The coaxial cable comprises: an inner conductor having a termination end; a dielectric layer that overlies the inner conductor; an outer conductor that overlies the dielectric layer having a termination end; and a jacket that overlies the outer conductor. The coaxial connector comprises: an inner conductor body configured to mate with the inner conductor extension of a mating coaxial cable jack, the inner conductor body attached to the termination end of the inner conductor; and an outer conductor body configured to mate with the outer conductor extension of the mating coaxial cable jack, the outer conductor body being electrically connected with the termination end of the outer conductor. The outer conductor body is crimped to the termination end of the outer conductor of the cable and is also crimped over the jacket.

[0010] As a fourth aspect, embodiments of the invention are directed to a method of forming a coaxial cable-connector assembly, comprising the steps of: (a) providing a coaxial cable comprising: an inner conductor having a termination end, the termination end including a bore; a dielectric layer that overlies the inner conductor; and an outer conductor that overlies the dielectric layer having a termination end; (b) providing a coaxial connector comprising: an inner conductor body configured to mate with the inner conductor body of a mating coaxial cable jack, the inner conductor body including a boss that encircles the termination end of the inner conductor, and further including a longitudinal bore; and an outer conductor body configured to mate with the outer conductor body of the mating coaxial cable jack, the outer conductor body being electrically connected with the termination end of the outer conductor; and (c) inserting an expansion member into the bore of the termination end of the inner conductor, the expansion member being sized and configured to radially expand the termination end of the inner conductor into electrical contact with the boss of the inner conductor body.

[0011] As a fifth aspect, embodiments of the invention are directed to a method of forming a coaxial cable-connector assembly, comprising the steps of: (a) providing a coaxial cable comprising: an inner conductor having a termination end; a dielectric layer that overlies the inner conductor; an outer conductor that overlies the dielectric layer having a termination

end; and a jacket that overlies the outer conductor; (b) providing a coaxial connector comprising: an inner conductor body configured to mate with the inner conductor extension of a mating coaxial cable jack, the inner conductor body attached to the termination end of the inner conductor; and an outer conductor body configured to mate with the outer conductor extension of the mating coaxial cable jack, the outer conductor body being electrically connected with the termination end of the outer conductor; (c) crimping the outer conductor body to the termination end of the outer conductor of the cable and (d) crimping the outer conductor body over the jacket.

[0012] As a sixth aspect, embodiments of the invention are directed to a cable-connector assembly, comprising a cable and a connector. The cable comprises a conductor having a termination end, the termination end including a bore. The connector comprises a conductor body configured to mate with a conductor body of a mating connector. An expansion member is inserted into the bore of the termination end of the conductor, the expansion member being sized and configured to radially expand the termination end of the conductor into electrical contact with the conductor body.

Brief Description of the Figures

[0013] **Figure 1** is a perspective section view of a cable-connector assembly according to embodiments of the present invention.

[0014] **Figure 2** is a perspective view of the outer conductor body of the assembly of **Figure 1**.

[0015] **Figure 3** is a perspective view of the assembly of **Figure 1** with the outer conductor body crimped into place.

[0016] **Figure 4** is a perspective view of the inner conductor body of the assembly of **Figure 1**.

[0017] **Figure 5** is a perspective view of the dowel of the assembly of **Figure 1**.

[0018] **Figure 6** is a perspective view of the connector end of the inner conductor and outer conductors of the cable of the assembly of **Figure 1**.

Detailed Description of Embodiments of the Invention

[0019] The present invention is described with reference to the accompanying drawings, in which certain embodiments of the invention are shown. This invention may, however, be embodied in many different forms and should not be construed as limited to the embodiments that are pictured and described herein; rather, these embodiments are provided so that this

disclosure will be thorough and complete, and will fully convey the scope of the invention to those skilled in the art. It will also be appreciated that the embodiments disclosed herein can be combined in any way and/or combination to provide many additional embodiments.

[0020] Unless otherwise defined, all technical and scientific terms that are used in this disclosure have the same meaning as commonly understood by one of ordinary skill in the art to which this invention belongs. The terminology used in the above description is for the purpose of describing particular embodiments only and is not intended to be limiting of the invention. As used in this disclosure, the singular forms "a", "an" and "the" are intended to include the plural forms as well, unless the context clearly indicates otherwise. It will also be understood that when an element (e.g., a device, circuit, etc.) is referred to as being "connected" or "coupled" to another element, it can be directly connected or coupled to the other element or intervening elements may be present. In contrast, when an element is referred to as being "directly connected" or "directly coupled" to another element, there are no intervening elements present.

[0021] Referring now to the drawings, a connector-cable assembly, designated broadly at **5**, is shown in **Figure 1**. The assembly **5** comprises a coaxial cable **10** and a plug **30**, each of which is described in detail below.

[0022] Referring to **Figures 1** and **6**, the coaxial cable **10** includes an inner conductor **12**, a dielectric layer **14** that circumferentially overlies the central conductor **12**, an outer conductor **16** that circumferentially overlies the dielectric layer **14**, and a polymeric cable jacket **20** that circumferentially overlies the outer conductor **16**. These components will be well-known to those of skill in this art and need not be described in detail herein. Notably, the inner conductor **12** includes a bore **12a** (best seen in **Figure 6**) at its terminal end. **Figures 1** and **6** illustrate that the outer conductor **16** may be of a corrugated profile; alternatively, the outer conductor **16** may have a smooth, braided or foil profile. All of these outer conductor configurations are known to those of skill in this art and need not be described in detail herein.

[0023] Referring to **Figures 1** and **4**, the plug **30** includes an inner conductor body **32** and an outer conductor body **34**. As can be seen in **Figures 1** and **4**, the inner conductor body **32** is generally cylindrical and comprises a sleeve **41** that includes a central bore **40** extending longitudinally therethrough. A boss **42** extends from one end of the sleeve **41**; the boss **42** has an inner diameter that is larger than that of the bore **40**, thereby creating a shoulder **43** (see **FIG. 1**), and has an outer diameter that is larger than that of the sleeve **41**, thereby creating a shoulder **48**. Two annular grooves **44**, **46** are present in the outer surface of the

sleeve 41, with the groove 44 forming part of the shoulder 48. A ridge 49 extends radially outwardly from the sleeve 41 near the chamfered tip 47. The inner conductor body 32 is configured to mate with the inner conductor body of a mating jack.

[0024] Referring now to **Figures 1-3**, the outer conductor body 34 is generally cylindrical and comprises multiple merging sections. A jacket crimping section 50 is present at one end, with a slightly smaller transition section 52 merging therewith. A slightly smaller conductor crimping section 54 merges with the transition section 52. A lip 56 is positioned radially inward of the conductor crimping section 54 and creates a gap 58 that is open in the direction of the jacket crimping section 50. A first hexagonal section 60 merges with the conductor crimping section 54, and a second, slightly larger hexagonal section 62 merges with the first hexagonal section 60; a shoulder 63 is created by the offset in the inner surfaces of the hexagonal sections 60, 62. A mating section 66 configured to mate with a mating jack merges with the second hexagonal section 62. A ring 68 extends radially outwardly from the mating section 66 and provides a bearing surface 82 for interaction with a coupling nut 80.

[0025] Referring now to **Figures 1 and 5**, a generally cylindrical dowel 70 includes a recess 72. The presence of the recess 72 forms a knob 74 at one end of the dowel 70. End 76 of the dowel 70 opposite the knob 74 is chamfered. **Figure 1** also illustrates a dielectric spacer 86 that separates the sleeve 41 of the inner conductor body 32 from the outer conductor body 34.

[0026] **Figure 1** illustrates the assembled plug 30 and cable 10. The jacket crimping section 50 of the outer conductor body 34 fits over the jacket 20 of the cable 10, with an optional sealing ring 90 (typically formed of a resilient material such as rubber or another elastomer) interposed between the jacket crimping section 50 and the jacket 20. The termination end of the outer conductor 16, which is flared outwardly to allow it to expand in diameter, fits within the gap 58 between the conductor crimping section 54 and the lip 56, with the lip 56 potentially serving as a stop for the termination end of the outer conductor 16. The boss 42 of the inner conductor body 32 fits over the outer surface of the inner conductor 12, such that the bore 12a aligns with the bore 40; the end of the inner conductor 12 may abut the shoulder 48 of the inner conductor body 32.

[0027] As can be seen in **Figure 3**, the outer conductor body 34 is secured to both the cable jacket 20 and the outer conductor 16 via crimping. **Figure 3** shows two grooves 92, 94 in the jacket crimping section 50 of the outer conductor body 34 formed by a crimping operation that forces the jacket crimping section 50 onto the jacket 20. This crimping is intended to produce a watertight seal, and can also create a mechanical fulcrum where

relative movement of the cable is not easily transmitted directly to either the outer or inner conductor interfaces. This can reduce the probability that the interfaces will experience relative motion, which can contribute to unacceptable levels of PIM.

[0028] **Figure 3** also illustrates a groove **96** formed in the conductor crimping section **54** formed by a crimping operation (which may be simultaneous with the crimping of the jacket crimping section **50**); the crimping of the conductor crimping section **54** forces the outer conductor **16** into contact with the conductor crimping section **50** and/or the lip **56** to provide high pressure electrical contact therebetween.

[0029] The inner conductor body **32** is attached to the inner conductor **12** of the cable **10** via the dowel **70**. More specifically, the diameter of the dowel **70** is slightly greater than the diameter of the bore **12a** of the inner conductor **12**. The dowel **70** is passed through the bore **40** of the inner conductor body **32** (starting at the flared tip **47**), then driven into the bore **12a** (typically at high speed and/or under high pressure). Because the dowel **70** is larger than the bore **12a**, it forces the bore **12a** radially outwardly to form a high pressure interference fit with the inner surface of the boss **42** that attaches the inner conductor **12** to the inner conductor body **32** and establishes electrical contact therewith.

[0030] Those skilled in this art will appreciate that the dowel **70** may be replaced with another variety of expansion member that causes the inner conductor **12** to expand radially outwardly sufficiently to form a joint with the boss **42** of the inner conductor body **32**. It should also be noted that, although the boss **42** is shown as a continuous annulus, it may be discontinuous; for example, it may include one or more slots to encourage radial expansion. Also, the dowel or other expansion member may have a smooth surface, or it may have a textured or roughened surface. For example, the dowel's outer surface may be completely or partially knurled (e.g., both ends may be knurled with a smooth central portion, or both ends may be smooth with a knurled central portion, one end may be smooth and the other knurled, etc.). Moreover, the dowel may be partially or completely hollow, which may effectively "soften" the dowel, thereby providing a preselected balance of joint strength and stress on the bore of the inner conductor of the cable. Further, in some embodiments, the dowel **70** or other expansion member may be combined into a single component with the inner conductor body **32** rather than being a separate and distinct component. Finally, the dowel or other expansion member may be used to connect other types of conductors, such as power conductors.

[0031] It can thus be seen that connectors according to embodiments of this invention can provide three interfaces within the same assembly where the clamping force is provided by

deflection/distortion of one of the members of the mating interface. By using high pressure interfaces rather than soldering, PIM can be reduced significantly.

[0032] Those of skill in this art will appreciate that, although the plug 30 is illustrated herein, a jack or other connector may be suitable for use with the concepts discussed above. Also, although a galvanic connection is anticipated between the plug 30 and a mating jack, the concepts may be employed with connectors designed for capacitive coupling (see, e.g., U.S Patent Application No. 14/303,745, filed June 13, 2014, the disclosure of which is hereby incorporated herein in its entirety). It should also be noted that any one of the three crimping operations may be employed independently, with the joining of the other two interfaces being achieved by other means.

[0033] The foregoing is illustrative of the present invention and is not to be construed as limiting thereof. Although exemplary embodiments of this invention have been described, those skilled in the art will readily appreciate that many modifications are possible in the exemplary embodiments without materially departing from the novel teachings and advantages of this invention. Accordingly, all such modifications are intended to be included within the scope of this invention as defined in the claims. The invention is defined by the following claims, with equivalents of the claims to be included therein.

That Which is Claimed is:

1. A coaxial cable-connector assembly, comprising:
 - (a) a coaxial cable comprising:
 - an inner conductor having a termination end, the termination end including a bore;
 - a dielectric layer that overlies the inner conductor;
 - an outer conductor that overlies the dielectric layer having a termination end; and
 - a jacket that overlies the outer conductor; and
 - (b) a coaxial connector comprising:
 - an inner conductor body configured to mate with the inner conductor body of a mating coaxial cable jack, the inner conductor body including a boss that encircles the termination end of the inner conductor, and further including a longitudinal bore;
 - an outer conductor body configured to mate with the outer conductor body of the mating coaxial cable jack, the outer conductor body being electrically connected with the termination end of the outer conductor; and
 - an expansion member inserted into the bore of the termination end of the inner conductor, the expansion member being sized and configured to radially expand the termination end of the inner conductor into electrical contact with the boss of the inner conductor body.
2. The assembly defined in Claim 1, wherein the expansion member extends into the bore of the inner conductor body.
3. The assembly defined in Claim 1, wherein the outer conductor body includes a radially inward lip, such that a gap is formed between the lip and an inner surface of the outer conductor body, and wherein the termination end of the outer conductor of the cable resides within the gap.
4. The assembly defined in Claim 3, wherein the outer conductor body is crimped onto the termination end of the outer conductor.
5. The assembly defined in Claim 3, wherein the lip serves as a stop for the outer conductor.

6. The assembly defined in Claim 1, further comprising a resilient sleeve interposed between the jacket and the outer conductor body.
7. The assembly defined in Claim 6, wherein the outer conductor body is crimped onto the resilient sleeve.
8. The assembly defined in Claim 4, further comprising a resilient sleeve interposed between the jacket, wherein the outer conductor body is crimped onto the resilient sleeve.
9. A coaxial connector comprising:
 - an inner conductor body configured to mate with the inner conductor body of a mating coaxial cable jack, the inner conductor body further configured to be attached to a termination end of an inner conductor of a coaxial cable;
 - an outer conductor body configured to mate with the outer conductor body of the mating coaxial cable jack, the outer conductor body further configured to be electrically connected with a termination end of an outer conductor of the coaxial cable;
 - wherein the outer conductor body further includes a radially inward lip, such that a gap is formed between the lip and an inner surface of the outer conductor body, and is configured to receive the termination end of the outer conductor of the cable resides within the gap; and
 - wherein the outer conductor body is configured to be crimped to the termination end of the outer conductor of the cable.
10. The connector defined in Claim 9, in combination with a coaxial cable comprising:
 - an inner conductor having a termination end;
 - a dielectric layer that overlies the inner conductor;
 - an outer conductor that overlies the dielectric layer having a termination end; and
 - a jacket that overlies the outer conductor.
11. The assembly defined in Claim 10, further comprising a resilient sleeve interposed between the jacket and the outer conductor body.

12. The assembly defined in Claim 11, wherein the outer conductor body is crimped onto the resilient sleeve.

13. The assembly defined in Claim 10, wherein the lip serves as a stop for the outer conductor.

14. A coaxial cable-connector assembly, comprising:

(a) a coaxial cable comprising:

an inner conductor having a termination end;

a dielectric layer that overlies the inner conductor;

an outer conductor that overlies the dielectric layer having a termination end; and

a jacket that overlies the outer conductor;

(b) a coaxial connector comprising:

an inner conductor body configured to mate with the inner conductor extension of a mating coaxial cable jack, the inner conductor body attached to the termination end of the inner conductor;

an outer conductor body configured to mate with the outer conductor extension of the mating coaxial cable jack, the outer conductor body being electrically connected with the termination end of the outer conductor;

wherein the outer conductor body is crimped to the termination end of the outer conductor of the cable and is also crimped over the jacket.

15. The assembly defined in Claim 14, further comprising a resilient sleeve interposed between the jacket and the outer conductor body.

16. The assembly defined in Claim 15, wherein the outer conductor body is crimped onto the resilient sleeve.

17. A method of forming a coaxial cable-connector assembly, comprising the steps of:

(a) providing a coaxial cable comprising:

an inner conductor having a termination end, the termination end including a bore;

a dielectric layer that overlies the inner conductor; and

an outer conductor that overlies the dielectric layer having a termination end;

(b) providing a coaxial connector comprising:

an inner conductor body configured to mate with the inner conductor body of a mating coaxial cable jack, the inner conductor body including a boss that encircles the termination end of the inner conductor, and further including a longitudinal bore; and

an outer conductor body configured to mate with the outer conductor body of the mating coaxial cable jack, the outer conductor body being electrically connected with the termination end of the outer conductor;

(c) inserting an expansion member into the bore of the termination end of the inner conductor, the expansion member being sized and configured to radially expand the termination end of the inner conductor into electrical contact with the boss of the inner conductor body.

18. A method of forming a coaxial cable-connector assembly, comprising the steps of:

(a) providing a coaxial cable comprising:

an inner conductor having a termination end;

a dielectric layer that overlies the inner conductor;

an outer conductor that overlies the dielectric layer having a termination end; and

a jacket that overlies the outer conductor;

(b) providing a coaxial connector comprising:

an inner conductor body configured to mate with the inner conductor extension of a mating coaxial cable jack, the inner conductor body attached to the termination end of the inner conductor;

an outer conductor body configured to mate with the outer conductor extension of the mating coaxial cable jack, the outer conductor body being electrically connected with the termination end of the outer conductor; and

(c) crimping the outer conductor body to the termination end of the outer conductor of the cable and

(d) crimping the outer conductor body over the jacket.

19. The method defined in Claim 18, wherein steps (c) and (d) are performed simultaneously.

20. A cable-connector assembly, comprising:

(a) a cable comprising a conductor having a termination end, the termination end including a bore;

(b) a connector comprising a conductor body configured to mate with a conductor body of a mating connector; and

(c) an expansion member inserted into the bore of the termination end of the conductor, the expansion member being sized and configured to radially expand the termination end of the conductor into electrical contact with the conductor body.

21. The assembly defined in Claim 20, wherein the expansion member is a separate and distinct component from the conductor body.

22. The assembly defined in Claim 21, wherein the conductor body includes a bore, and wherein the expansion member is inserted into the bore of the conductor body.

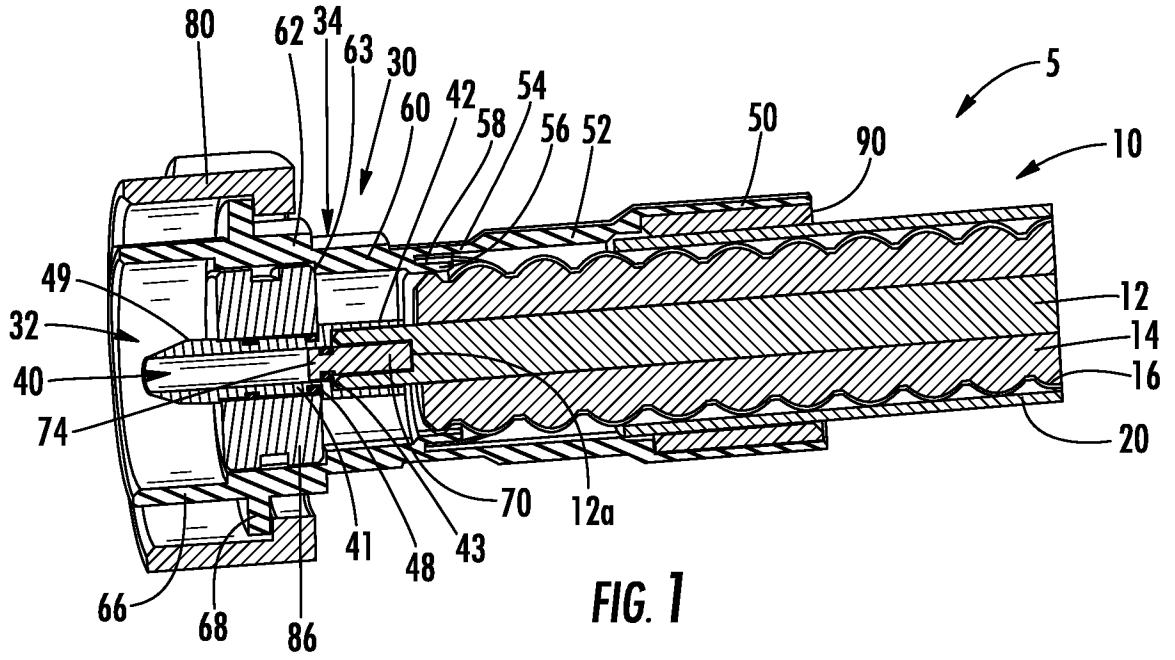

FIG. 1

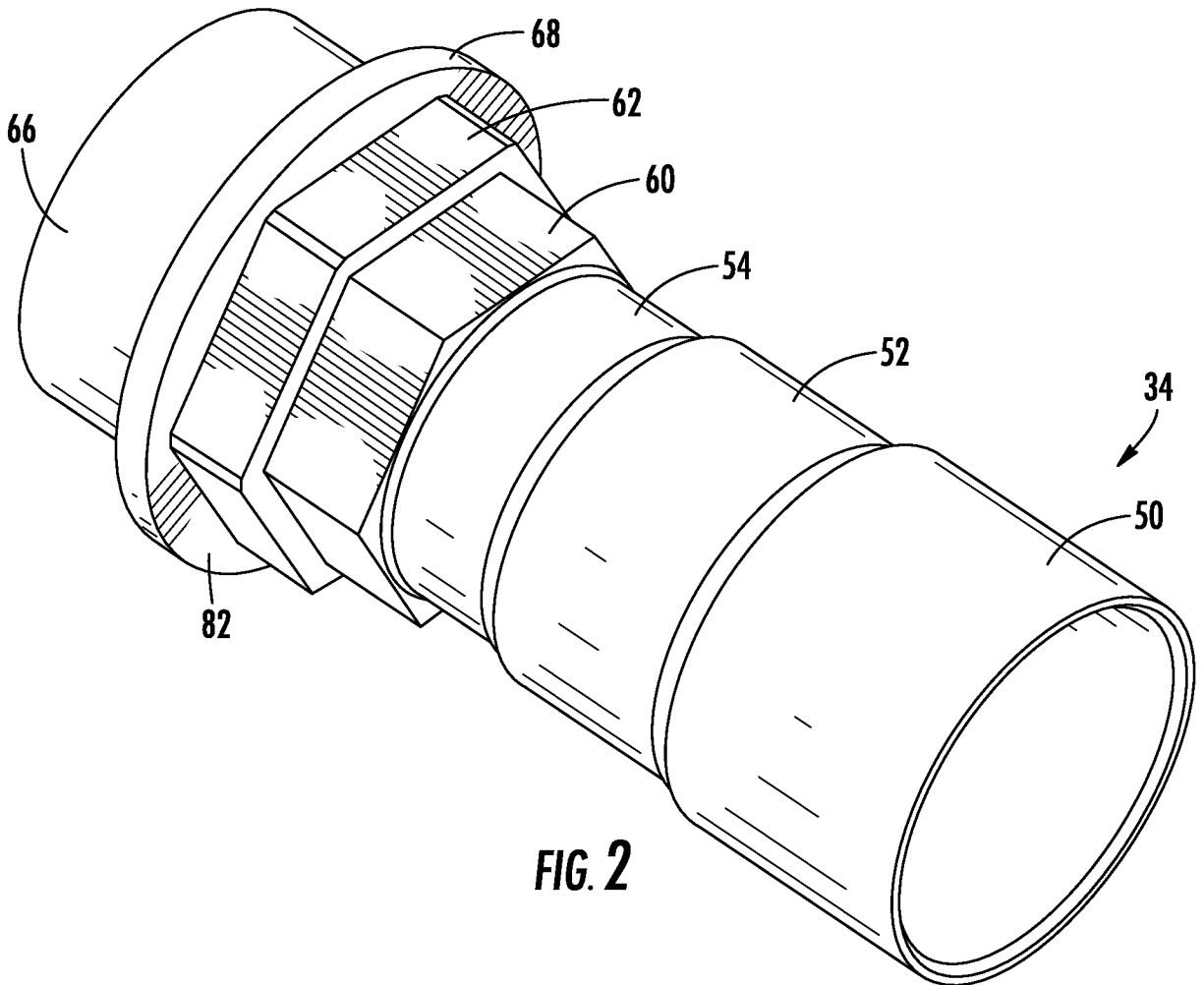

FIG. 2

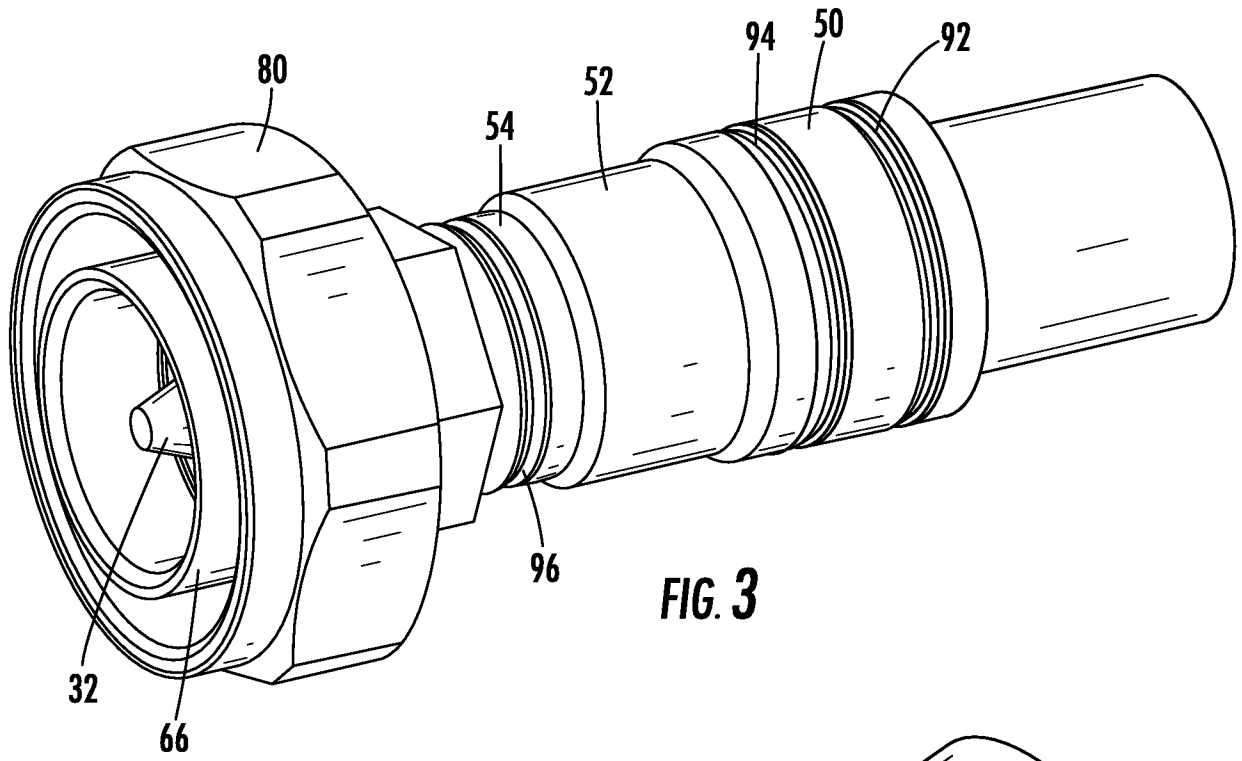

FIG. 3

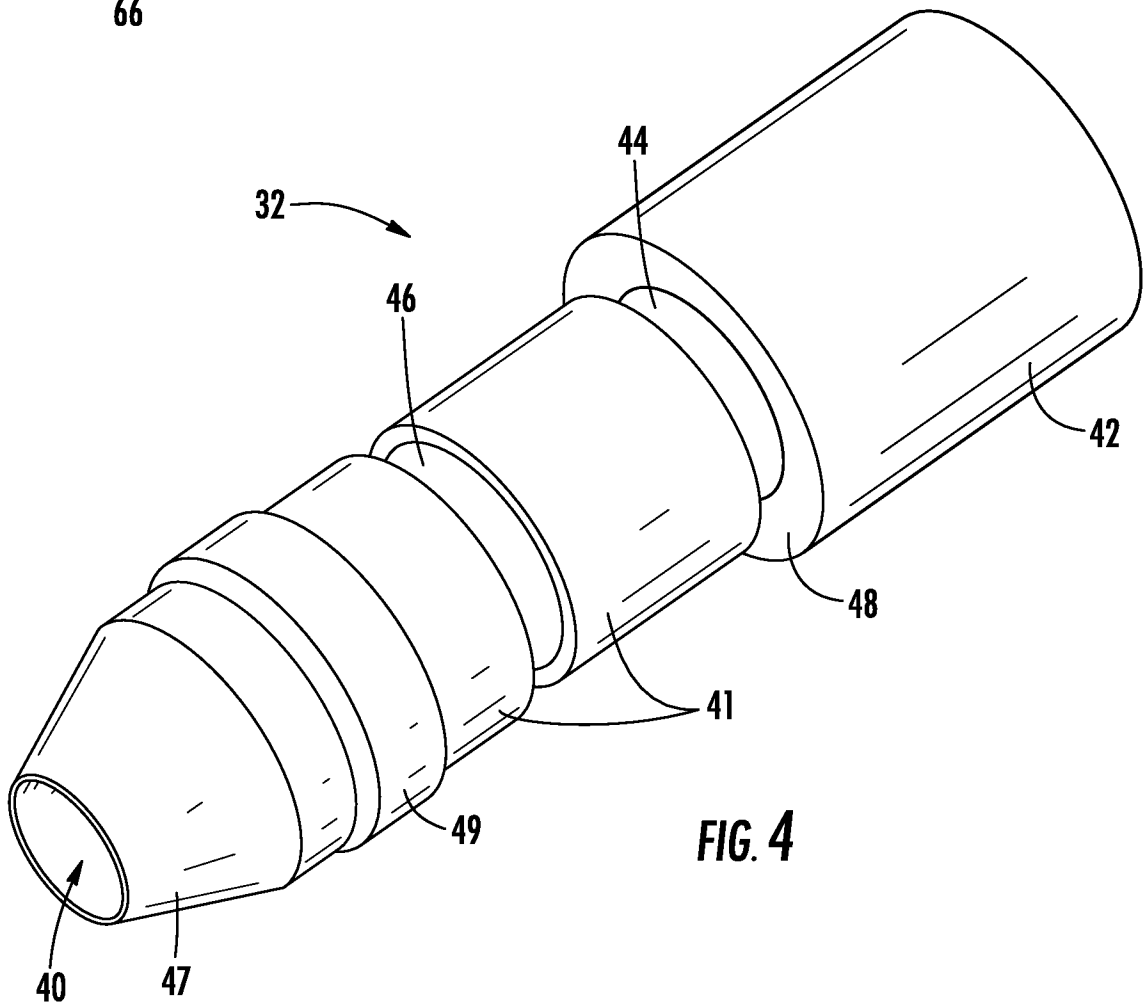
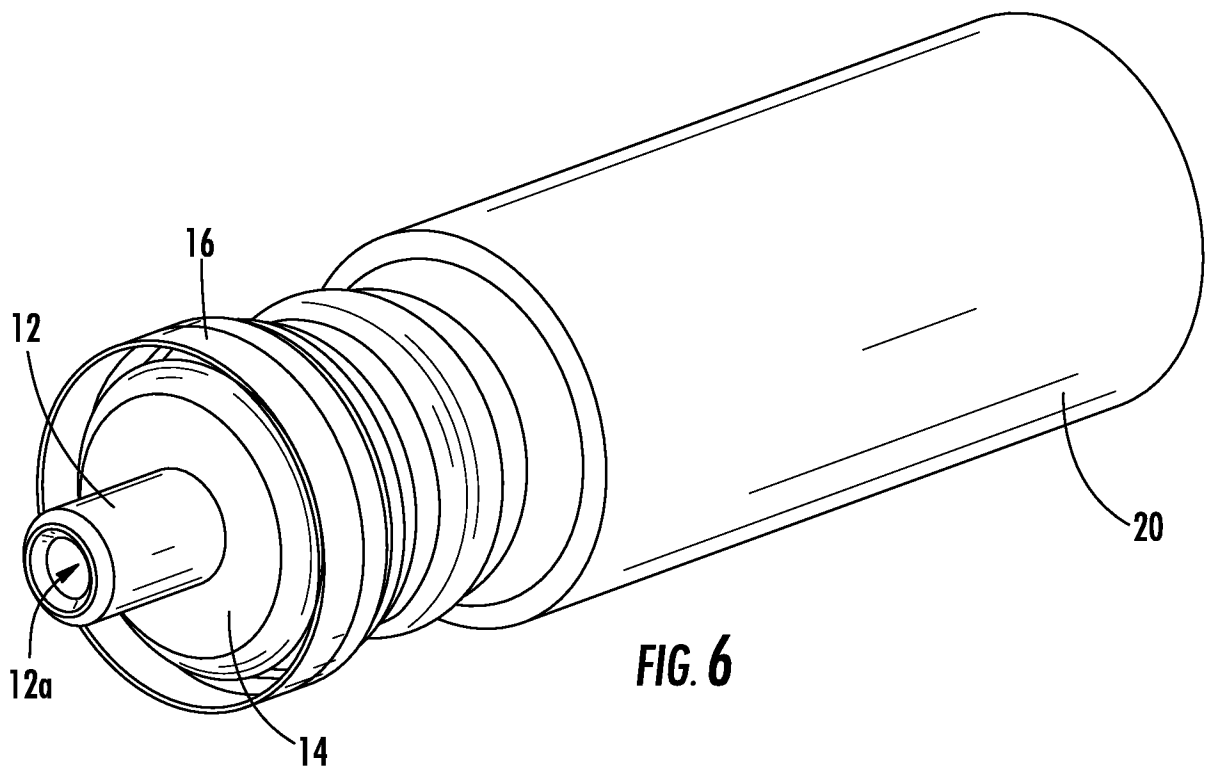
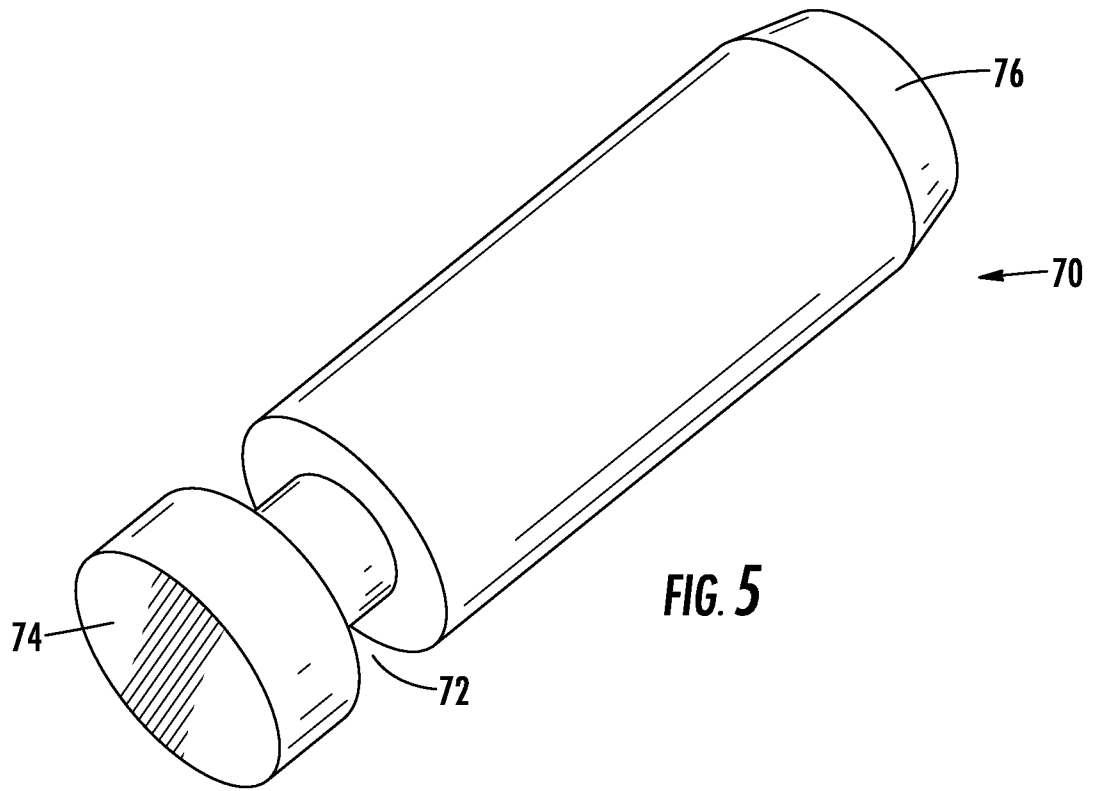

FIG. 4



INTERNATIONAL SEARCH REPORT

International application No.
PCT/US2015/049355**A. CLASSIFICATION OF SUBJECT MATTER****H01R 24/38(2011.01)i, H01R 9/05(2006.01)i**

According to International Patent Classification (IPC) or to both national classification and IPC

B. FIELDS SEARCHEDMinimum documentation searched (classification system followed by classification symbols)
H01R 24/38; H01R 13/646; H01R 43/02; H01R 43/00; H01R 13/52; H01R 9/05Documentation searched other than minimum documentation to the extent that such documents are included in the fields searched
Korean utility models and applications for utility models
Japanese utility models and applications for utility modelsElectronic data base consulted during the international search (name of data base and, where practicable, search terms used)
eKOMPASS(KIPO internal) & Keywords: coaxial cable, connector, expansion member, crimping**C. DOCUMENTS CONSIDERED TO BE RELEVANT**

Category*	Citation of document, with indication, where appropriate, of the relevant passages	Relevant to claim No.
Y	US 2012-0129391 A1 (KENDRICK VAN SWEARINGEN et al.) 24 May 2012 See abstract, paragraphs [0033]-[0043] and figures 4-5, 14.	9-16, 18-19
A		1-8, 17, 20-22
Y	US 2013-0034983 A1 (JOHN MEZZALINGUA ASSOCIATES, INC.) 07 February 2013 See abstract, paragraph [0072] and figures 2-5.	9-13
Y	US 2013-0143439 A1 (JOHN MEZZALINGUA ASSOCIATES, INC.) 06 June 2013 See abstract, paragraphs [0080], [0102] and figures 1, 3.	9-16, 18-19
A	KR 10-2011-0125922 A (LS CABLE & SYSTEM LTD.) 22 November 2011 See abstract, paragraphs [0016]-[0029], claim 1 and figure 1.	1-22
A	US 2012-0064768 A1 (NAHID ISLAM et al.) 15 March 2012 See abstract, paragraphs [0035]-[0041] and figures 1-3.	1-22

 Further documents are listed in the continuation of Box C. See patent family annex.

* Special categories of cited documents:

"A" document defining the general state of the art which is not considered to be of particular relevance

"E" earlier application or patent but published on or after the international filing date

"L" document which may throw doubts on priority claim(s) or which is cited to establish the publication date of another citation or other special reason (as specified)

"O" document referring to an oral disclosure, use, exhibition or other means

"P" document published prior to the international filing date but later than the priority date claimed

"T" later document published after the international filing date or priority date and not in conflict with the application but cited to understand the principle or theory underlying the invention

"X" document of particular relevance; the claimed invention cannot be considered novel or cannot be considered to involve an inventive step when the document is taken alone

"Y" document of particular relevance; the claimed invention cannot be considered to involve an inventive step when the document is combined with one or more other such documents, such combination being obvious to a person skilled in the art

"&" document member of the same patent family

Date of the actual completion of the international search

22 December 2015 (22.12.2015)

Date of mailing of the international search report

22 December 2015 (22.12.2015)

Name and mailing address of the ISA/KR

International Application Division
Korean Intellectual Property Office
189 Cheongsa-ro, Seo-gu, Daejeon, 35208, Republic of Korea

Facsimile No. +82-42-472-7140

Authorized officer

KIM, Sung Gon

Telephone No. +82-42-481-8746

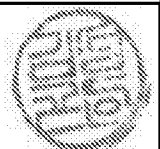

INTERNATIONAL SEARCH REPORT

Information on patent family members

International application No.

PCT/US2015/049355

Patent document cited in search report	Publication date	Patent family member(s)	Publication date
US 2012-0129391 A1	24/05/2012	CN 103210551 A	17/07/2013
		CN 103210552 A	17/07/2013
		CN 103221196 A	24/07/2013
		CN 103222119 A	24/07/2013
		CN 103222124 A	24/07/2013
		CN 103222125 A	24/07/2013
		CN 103222126 A	24/07/2013
		CN 103299491 A	11/09/2013
		CN 103299491 B	16/09/2015
		CN 103380547 A	30/10/2013
		CN 103843207 A	04/06/2014
		CN 103875136 A	18/06/2014
		CN 103907246 A	02/07/2014
		CN 104737386 A	24/06/2015
		EP 2643146 A1	02/10/2013
		EP 2643894 A1	02/10/2013
		EP 2643895 A2	02/10/2013
		EP 2643896 A1	02/10/2013
		EP 2643897 A1	02/10/2013
		EP 2643898 A1	02/10/2013
		EP 2643899 A1	02/10/2013
		EP 2643900 A1	02/10/2013
		EP 2643901 A1	02/10/2013
		EP 2777098 A1	17/09/2014
		EP 2777099 A1	17/09/2014
		EP 2777100 A1	17/09/2014
		EP 2904668 A1	12/08/2015
		EP 2917977 A1	16/09/2015
		EP 2917979 A1	16/09/2015
		EP 2917980 A1	16/09/2015
		EP 2917981 A1	16/09/2015
		US 2012-0125513 A1	24/05/2012
		US 2012-0125654 A1	24/05/2012
		US 2012-0129375 A1	24/05/2012
		US 2012-0129383 A1	24/05/2012
		US 2012-0129384 A1	24/05/2012
		US 2012-0129388 A1	24/05/2012
		US 2012-0129389 A1	24/05/2012
		US 2012-0129390 A1	24/05/2012
		US 2012-0302088 A1	29/11/2012
		US 2013-0025121 A1	31/01/2013
		US 2013-0037299 A1	14/02/2013
		US 2013-0037300 A1	14/02/2013
		US 2013-0037301 A1	14/02/2013
		US 2013-0037320 A1	14/02/2013
		US 2013-0038410 A1	14/02/2013
		US 2013-0038411 A1	14/02/2013
		US 2013-0038412 A1	14/02/2013
		US 2013-0065415 A1	14/03/2013

INTERNATIONAL SEARCH REPORT

Information on patent family members

International application No.

PCT/US2015/049355

Patent document cited in search report	Publication date	Patent family member(s)	Publication date
		US 2013-0065420 A1	14/03/2013
		US 2013-0065422 A1	14/03/2013
		US 2013-0102178 A1	25/04/2013
		US 2013-0102200 A1	25/04/2013
		US 2014-0134863 A1	15/05/2014
		US 2014-0134875 A1	15/05/2014
		US 2014-0134876 A1	15/05/2014
		US 2014-0134878 A1	15/05/2014
		US 2015-0038010 A1	05/02/2015
		US 8302296 B2	06/11/2012
		US 8365404 B2	05/02/2013
		US 8453320 B2	04/06/2013
		US 8479383 B2	09/07/2013
		US 8550843 B2	08/10/2013
		US 8550859 B2	08/10/2013
		US 8563861 B2	22/10/2013
		US 8608507 B2	17/12/2013
		US 8622762 B2	07/01/2014
		US 8622768 B2	07/01/2014
		US 8747152 B2	10/06/2014
		US 8801460 B2	12/08/2014
		US 8826525 B2	09/09/2014
		US 8876549 B2	04/11/2014
		US 8887388 B2	18/11/2014
		US 8888528 B2	18/11/2014
		US 8894439 B2	25/11/2014
		US 9048527 B2	02/06/2015
		WO 2012-071079 A1	31/05/2012
		WO 2012-071080 A1	31/05/2012
		WO 2012-071081 A1	31/05/2012
		WO 2012-071082 A1	31/05/2012
		WO 2012-071083 A1	31/05/2012
		WO 2012-071084 A1	31/05/2012
		WO 2012-071085 A1	31/05/2012
		WO 2012-071106 A1	31/05/2012
		WO 2012-071234 A2	31/05/2012
		WO 2013-025268 A1	21/02/2013
		WO 2013-025269 A1	21/02/2013
		WO 2013-025488 A2	21/02/2013
		WO 2013-025500 A2	21/02/2013
		WO 2013-025506 A2	21/02/2013
		WO 2013-025509 A2	21/02/2013
		WO 2013-025514 A2	21/02/2013
		WO 2013-025515 A2	21/02/2013
		WO 2013-058785 A1	25/04/2013
		WO 2013-071202 A1	16/05/2013
		WO 2013-071204 A1	16/05/2013
		WO 2013-071205 A1	16/05/2013
		WO 2013-071206 A1	16/05/2013
		WO 2014-055215 A1	10/04/2014

INTERNATIONAL SEARCH REPORT

Information on patent family members

International application No.

PCT/US2015/049355

Patent document cited in search report	Publication date	Patent family member(s)	Publication date
		WO 2014-074219 A1	15/05/2014
		WO 2014-074222 A1	15/05/2014
		WO 2014-074223 A1	15/05/2014
		WO 2014-074798 A1	15/05/2014
US 2013-0034983 A1	07/02/2013	AR 076791A1	06/07/2011
		AU 2010-249855 A1	02/02/2012
		AU 2010-249855 A2	08/03/2012
		CA 2762283 A1	25/11/2010
		CA 2895030 A1	25/11/2010
		CN 101944688 A	12/01/2011
		CN 201904508 U	20/07/2011
		DK 2436088 T3	10/08/2015
		EP 2436088 A2	04/04/2012
		EP 2436088 B1	29/04/2015
		EP 2797178 A1	29/10/2014
		GB 201109575 D0	20/07/2011
		GB 2477479 A	03/08/2011
		GB 2477479 B	30/11/2011
		JP 2012-527730 A	08/11/2012
		KR 10-2012-0030448 A	28/03/2012
		KR 10-2015-0080630 A	09/07/2015
		MX 2011012290 A	08/12/2011
		TW 201042852 A	01/12/2010
		TW I436533 B	01/05/2014
		US 2010-0297875 A1	25/11/2010
		US 2011-0143567 A1	16/06/2011
		US 2012-0222302 A1	06/09/2012
		US 2012-0270428 A1	25/10/2012
		US 2013-0065435 A1	14/03/2013
		US 2013-0072059 A1	21/03/2013
		US 2014-0030916 A1	30/01/2014
		US 2014-0099814 A1	10/04/2014
		US 2014-0106592 A1	17/04/2014
		US 2014-0106615 A1	17/04/2014
		US 2014-0220807 A1	07/08/2014
		US 2014-0322967 A1	30/10/2014
		US 8192237 B2	05/06/2012
		US 8287320 B2	16/10/2012
		US 8313353 B2	20/11/2012
		US 8323060 B2	04/12/2012
		US 8562366 B2	22/10/2013
		US 8597041 B2	03/12/2013
		US 8647136 B2	11/02/2014
		US 8801448 B2	12/08/2014
		WO 2010-135181 A2	25/11/2010
		WO 2010-135181 A3	03/02/2011
US 2013-0143439 A1	06/06/2013	US 9172156 B2	27/10/2015
		WO 2014-066807 A2	01/05/2014

INTERNATIONAL SEARCH REPORT

Information on patent family members

International application No.

PCT/US2015/049355

Patent document cited in search report	Publication date	Patent family member(s)	Publication date
		WO 2014-066807 A3	01/05/2014
KR 10-2011-0125922 A	22/11/2011	None	
US 2012-0064768 A1	15/03/2012	CN 102449851 A	09/05/2012
		CN 102449852 A	09/05/2012
		CN 102449853 A	09/05/2012
		CN 102576947 A	11/07/2012
		EP 2438652 A1	11/04/2012
		EP 2438653 A1	11/04/2012
		EP 2438654 A1	11/04/2012
		EP 2438655 A1	11/04/2012
		KR 10-2012-0026521 A	19/03/2012
		KR 10-2012-0030069 A	27/03/2012
		KR 10-2012-0030070 A	27/03/2012
		KR 10-2012-0030071 A	27/03/2012
		US 2012-0064764 A1	15/03/2012
		US 2012-0064765 A1	15/03/2012
		US 2012-0064767 A1	15/03/2012
		US 8393919 B2	12/03/2013
		US 8454384 B2	04/06/2013
		US 8545263 B2	01/10/2013
		US 8678858 B2	25/03/2014
		WO 2010-141880 A1	09/12/2010
		WO 2010-141890 A1	09/12/2010
		WO 2010-141898 A1	09/12/2010
		WO 2010-141905 A1	09/12/2010