

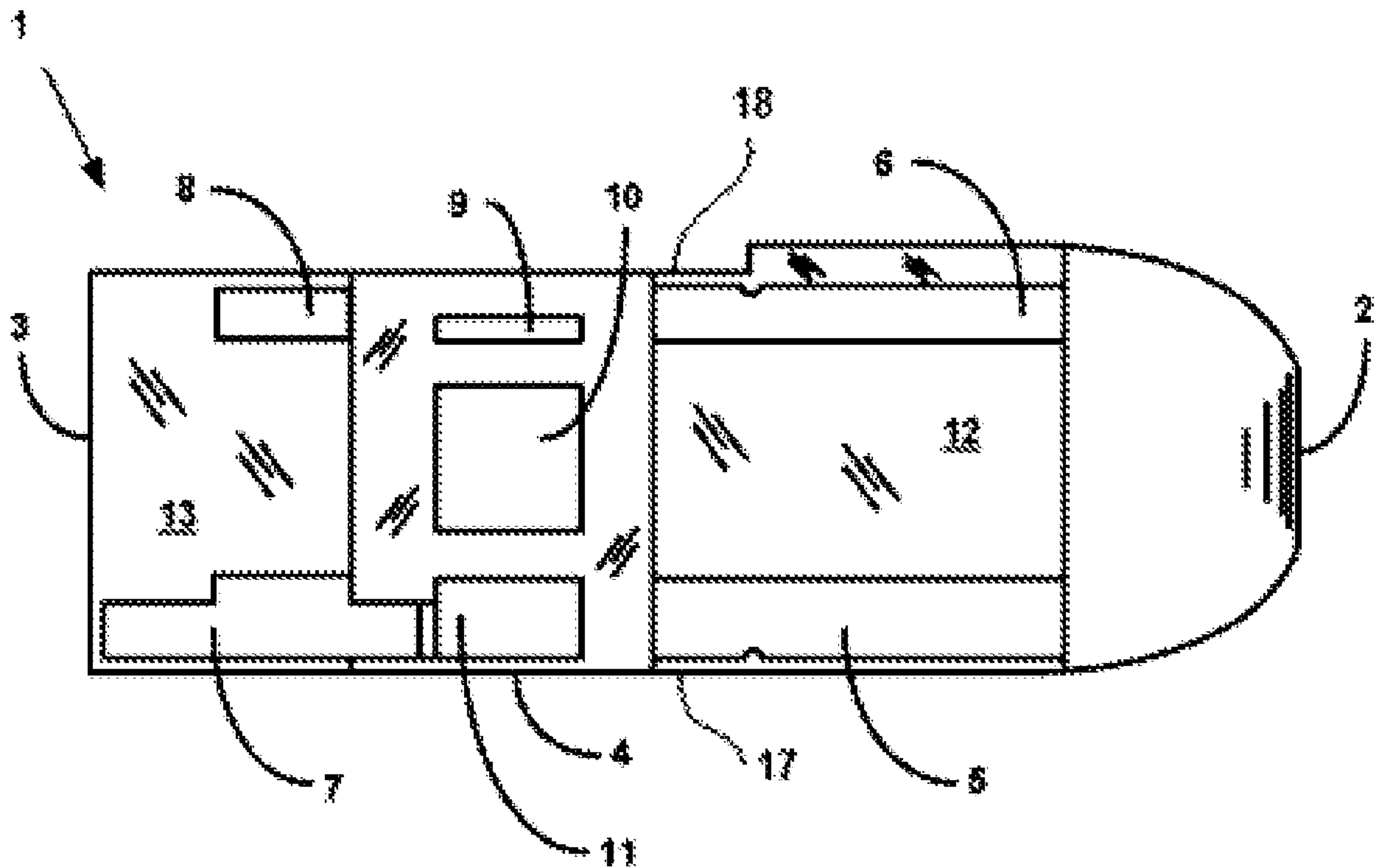

(86) **Date de dépôt PCT/PCT Filing Date:** 2012/07/27
 (87) **Date publication PCT/PCT Publication Date:** 2013/02/07
 (45) **Date de délivrance/Issue Date:** 2018/12/11
 (85) **Entrée phase nationale/National Entry:** 2014/01/29
 (86) **N° demande PCT/PCT Application No.:** US 2012/048617
 (87) **N° publication PCT/PCT Publication No.:** 2013/019645
 (30) **Priorité/Priority:** 2011/07/29 (US61/513,011)

(51) **Cl.Int./Int.Cl. B60S 1/40** (2006.01)
 (72) **Inventeurs/Inventors:**
 TOLENTINO, VAMBI RAYMUNDO, US;
 PEERS, ROBERT PETER, US
 (73) **Propriétaire/Owner:**
 PYLON MANUFACTURING CORP., US
 (74) **Agent:** GOWLING WLG (CANADA) LLP

(54) **Titre : CONNECTEUR D'ESSUIE-GLACE**
 (54) **Title: WINDSHIELD WIPER CONNECTOR**



(57) **Abrégé/Abstract:**

A connector (1) for a windshield wiper, and a wiper blade assembly including same, that accommodates multiple pin-type windshield wiper arms having varying pin lengths and locking mechanisms. The connector for connecting a windshield wiper assembly to a wiper arm may have a peripheral wall (4) having at least two opposing peripheral side walls (17, 18) and a top surface extending from one of the two opposing peripheral side walls to the other. The opposing peripheral side walls (4) may each have a retaining pin aperture aligned with one another and sized to be capable of slidably accepting a retaining pin of at least one pin-type windshield wiper arm.

(12) INTERNATIONAL APPLICATION PUBLISHED UNDER THE PATENT COOPERATION TREATY (PCT)

(19) World Intellectual Property
Organization
International Bureau

WIPO | PCT

(10) International Publication Number
WO 2013/019645 A1(43) International Publication Date
7 February 2013 (07.02.2013)(51) International Patent Classification:
B60S 1/40 (2006.01)(21) International Application Number:
PCT/US2012/048617(22) International Filing Date:
27 July 2012 (27.07.2012)

(25) Filing Language: English

(26) Publication Language: English

(30) Priority Data:
61/513,011 29 July 2011 (29.07.2011) US(71) Applicant (for all designated States except US): **PYLON
MANUFACTURING CORP.** [US/US]; 1341 Newport
Center Drive West, Deerfield Beach, FL 33442 (US).

(72) Inventors; and

(75) Inventors/Applicants (for US only): **TOLENTINO,
Vambi, Raymundo** [US/US]; 1921 Nw 35th Terrace,
Coconut Creek, FL 33066 (US). **PEERS, Robert, Peter**
[US/US]; 23157 Sw 56th Avenue, Boca Raton, FL 33433
(US).(74) Agents: **SOBRADO, Javier** et al.; Feldman Gale, P.A.,
1700 Market Street, Suite 3130, Philadelphia, PA 19103
(US).(81) Designated States (unless otherwise indicated, for every
kind of national protection available): AE, AG, AL, AM,
AO, AT, AU, AZ, BA, BB, BG, BH, BN, BR, BW, BY,
BZ, CA, CH, CL, CN, CO, CR, CU, CZ, DE, DK, DM,
DO, DZ, EC, EE, EG, ES, FI, GB, GD, GE, GH, GM, GT,
HN, HR, HU, ID, IL, IN, IS, JP, KE, KG, KM, KN, KP,
KR, KZ, LA, LC, LK, LR, LS, LT, LU, LY, MA, MD,
ME, MG, MK, MN, MW, MX, MY, MZ, NA, NG, NI,
NO, NZ, OM, PE, PG, PH, PL, PT, QA, RO, RS, RU, RW,
SC, SD, SE, SG, SK, SL, SM, ST, SV, SY, TH, TJ, TM,
TN, TR, TT, TZ, UA, UG, US, UZ, VC, VN, ZA, ZM,
ZW.(84) Designated States (unless otherwise indicated, for every
kind of regional protection available): ARIPO (BW, GH,
GM, KE, LR, LS, MW, MZ, NA, RW, SD, SL, SZ, TZ,
UG, ZM, ZW), Eurasian (AM, AZ, BY, KG, KZ, RU, TJ,
TM), European (AL, AT, BE, BG, CH, CY, CZ, DE, DK,
EE, ES, FI, FR, GB, GR, HR, HU, IE, IS, IT, LT, LU, LV,
MC, MK, MT, NL, NO, PL, PT, RO, RS, SE, SI, SK, SM,
TR), OAPI (BF, BJ, CF, CG, CI, CM, GA, GN, GQ, GW,
ML, MR, NE, SN, TD, TG).

Published:

— with international search report (Art. 21(3))

(54) Title: WINDSHIELD WIPER CONNECTOR

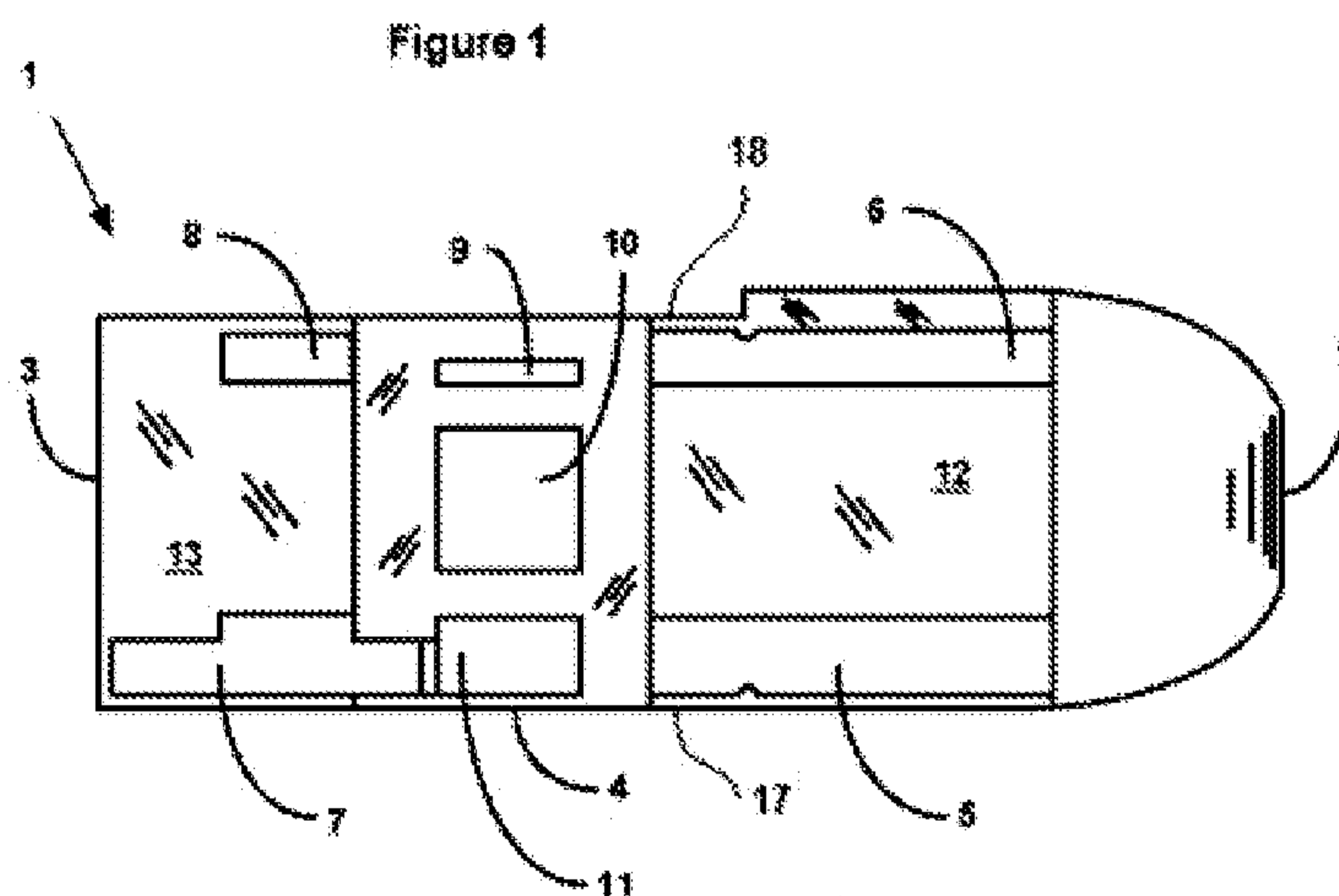

(57) Abstract: A connector (1) for a windshield wiper, and a wiper blade assembly including same, that accommodates multiple pin-type windshield wiper arms having varying pin lengths and locking mechanisms. The connector for connecting a windshield wiper assembly to a wiper arm may have a peripheral wall (4) having at least two opposing peripheral side walls (17, 18) and a top surface extending from one of the two opposing peripheral side walls to the other. The opposing peripheral side walls (4) may each have a retaining pin aperture aligned with one another and sized to be capable of slidably accepting a retaining pin of at least one pin-type windshield wiper arm.



WO 2013/019645 A1

WINDSHIELD WIPER CONNECTOR

5

TECHNICAL FIELD

This invention relates in general to windshield wipers, and more particularly, to an improved connector for a windshield wiper that allows the windshield wiper to be attached to multiple pin-type windshield wiper arm configurations. The invention is also directed to windshield wipers incorporating these novel connectors.

10

BACKGROUND OF THE INVENTION

There are a variety of wiper arms on which wiper blades are provided as original equipment. These various wiper arms have hooks, pins, or other configurations which may connect to the wiper blade with or without connectors. These various configurations have created a problem in the replacement market because wiper blade providers are required to have multiple wiper blade configurations to accommodate all of the existing wiper arms. It is therefore advantageous to have attachment structures that can accommodate a host of arms to reduce the complexity and cost associated with this problem.

15

The need to attach replacement windshield wiper blades to multiple arms has been addressed to some degree. For example, windshield wiper blades have been designed to work with various hook-type wiper arms having different sizes. Connectors may also be configured to receive either a pin-type arm or a hook arm. While these connectors may increase the usefulness of a given windshield wiper such that it can be used with different wiper arm types, the connectors are often expensive and have a complicated structure that is difficult and time-consuming to manufacture

20

25

More recent side pin arms are described in U.S. Patent No. 6,553,607. These side pin arms do not have the reduced radius groove found in traditional pin arms (which was used to lock the pin in place), in favor of a constant-radius pin. Such arms use a locking mechanism with a locking tab that is designed to extend from one side of the wiper blade to the other and secure the arm in place laterally, while the pin secures the wiper blade from longitudinal movement. These wiper arms (sometimes referred to herein as "pin-plus-locking-arm") are generally provided on vehicles with a specially designed wiper blade that is designed to

30

connect only to that specific type of arm. Thus, when the wiper blade must be replaced, the replacement must generally be done at a car dealership and requires the purchase of an expensive replacement part. Moreover, there are several versions of these pin-plus-locking-arm wiper arms, some of which have varying lengths, locking arms or spacers. Accordingly, an aftermarket provider that offers windshield wipers that are not directed to a specific car must evaluate whether to add a separate connector to accommodate each particular pin-plus-locking-arm wiper arms (in addition to the connectors that accommodate the various size hook arms, traditional pin arms, etc.). This leaves consumers with vehicles having the new pin-plus-locking arm wiper arms with fewer, usually more expensive, alternatives for replacement windshield wipers.

Thus, there is a need for inexpensive connectors that are capable of securing a windshield wiper blade to a variety of arms, including pin-plus-locking-arm wiper arms. In particular, it would be desirable to have a connector that can be attached to a wiper blade that will allow the wiper blade to be locked to a wide variety of these pin-type wiper arms despite their various locking arm mechanisms and regardless of whether the arm includes a spacer. It would also be desirable to have a windshield wiper connector that can be fabricated or molded as a single piece at low-cost, and that can accommodate a wide variety of these pin-type wiper arms. The prior art fails to provide a low-cost windshield wiper connector capable of attachment to a wide variety of these pin-type windshield wiper arms, much less for the purpose of reducing the amounts of inventory parts required to supply a vehicle market that uses a wide variety of pin-type windshield wiper arm types.

SUMMARY OF THE INVENTION

This invention is generally directed to novel connectors for windshield wiper blades. More particularly, the invention relates, in part, to a single piece windshield wiper connector that can accommodate multiple pin-type windshield wiper arms having varying pin lengths and locking mechanisms. In certain embodiments the connector for connecting a windshield wiper assembly to a wiper arm may have a peripheral wall having at least two opposing peripheral side walls and a top surface extending from one of the two opposing peripheral side walls to the other. The opposing peripheral side walls may each have a retaining pin aperture aligned with one another and sized to be capable of slidably accepting a retaining pin of at least one pin-type windshield wiper arm. The invention is also directed to wiper blades incorporating the connectors described herein.

BRIEF DESCRIPTION OF THE DRAWINGS

Figure 1 is a top view of a preferred embodiment of the connector that illustrates the aperture and outside edge used to accommodate different locking tab configurations.

5 Figure 2 is a bottom view of a preferred embodiment of the connector that illustrates the internal support structure inside the connector.

Figure 3 shows a cross-section of a preferred embodiment of the connector along the line A-A of Figure 2.

Figure 4 is a side view of a preferred embodiment of the connector that illustrates a first side of the connector.

10 Figure 5 is a side view of a preferred embodiment of the connector that illustrates a second side of the connector.

Figure 6 is distal end view of a preferred embodiment of the connector.

Figure 7 is a proximal end view of a preferred embodiment of the connector.

15 Figure 8 is a top view of a first prior art wiper arm that illustrates the support arm, the locking arm, and the retaining pin.

Figure 9 is a distal end view of the wiper arm of figure 8 that illustrates the support arm, the locking arm, and the locking tab in relation to the retaining pin.

20 Figure 10 is a proximal end view of a preferred embodiment of the connector connecting to the wiper arm of figure 8 (shown in top view) illustrating the connector slipped over the retaining pin prior to being rotated to the secured position.

Figure 11 is a top view of the embodiment of the connector connecting to the wiper arm of figure 8 illustrating the connector turned to the secured position and locked to the windshield wiper arm.

25 Figure 12 is a top view of a second prior art wiper arm having a spacer that illustrates the support arm, the locking arm, and the retaining pin.

Figure 13 is a distal end view of the wiper arm of figure 12 that illustrates the support arm, the locking arm, and the locking tab in relation to the retaining pin.

30 Figure 14 is a distal end view of a preferred embodiment of the connector connecting to the wiper arm of figure 12 (shown in top view) illustrating the connector slipped over the retaining pin prior to being rotated to the secured position.

Figure 15 is a top view of a preferred embodiment of the connector connecting to the wiper arm of figure 12 illustrating the connector turned to the secured position and locked to the windshield wiper arm.

5 Figure 16 is a top view of a third prior art wiper arm that illustrates the support arm, the locking arm, and the retaining pin.

Figure 17 is a distal end view of the wiper arm of figure 16 that illustrates the support arm, the locking arm, and the locking tab in relation to the retaining pin.

10 Figure 18 is a proximal end view of a preferred embodiment of the connector connecting to the wiper arm of figure 16 (shown in top view) illustrating the connector slipped over the retaining pin prior to being rotated to the secured position.

Figure 19 is a top view of a preferred embodiment of the connector, connecting to the wiper arm of Figure 16, illustrating the connector turned to the secured position and locked to the windshield wiper arm.

15 Figure 20 is a perspective view of a second preferred embodiment of the connector, connector showing the distal, top and a first side of the connector.

Figure 21 is a perspective view of a second preferred embodiment of the connector showing the second side and bottom.

20 Figure 22 is a top view of a second preferred embodiment of the connector that illustrates the aperture and outside edge used to accommodate different locking tab configurations.

Figure 23 is a bottom view of a second preferred embodiment of the connector that illustrates the internal support structure inside the connector .

Figure 24 is a side view of a second preferred embodiment of the connector that illustrates a first side of the connector.

25 Figure 25 is a cross-sectional side view of the internal support wall near the first side of a second preferred embodiment of the connector.

Figure 26 is a side view of a second preferred embodiment of the connector that illustrates a second side of the connector.

30 Figure 27 is a cross-sectional side view of the internal support wall near the second side of a second preferred embodiment of the connector.

DETAILED DESCRIPTION OF THE PREFERRED EMBODIMENT

In one aspect, the invention is generally directed to a connector **1** for a windshield wiper (or a windshield wiper incorporating same) that allows one windshield wiper to be secured to multiple windshield wiper arms, each having a different configuration.. In this aspect, the connector **1** may be designed for use with multiple different windshield wiper arms that use transverse retaining pins **22** and locking arms **21** that secure the windshield wiper to the windshield wiper arm.

In certain embodiments the connector for connecting a windshield wiper assembly to a wiper arm may have a peripheral wall having at least two opposing peripheral side walls and a top surface extending from one of the two opposing peripheral side walls to the other. The opposing peripheral side walls may each have a retaining pin aperture aligned with one another and sized to be capable of slidably accepting a retaining pin of at least one pin-type windshield wiper arm.

In some embodiments, the connector may further have an aperture in the top surface sized such that it is capable of accepting a first locking tab that extends from a locking arm on a first pin-type of windshield wiper arm. The distance between the outside surfaces of the peripheral side walls may be such that the connector is capable of being attached to a second pin-type windshield wiper arm, such that a second locking arm of the second pin-type windshield wiper arm extends past the at least two opposing peripheral side walls of the connector and the locking tab extends along an outer surface of one of the at least two opposing peripheral side walls of the connector.

In some embodiments, the top surface of the connector may further have a proximal shelf and a distal shelf such that the connector is capable of having the bottom side of the first and/or second locking arms of the first and/or second pin-type windshield wiper arms rest on the proximal shelf when the connector is locked to each of the first pin-type and second pin-type windshield wiper arms. In some of these embodiments, the proximal shelf of the connector may be recessed.

In some embodiments, the connector may have at least two internal support walls, and at least one rivet passage and arcuate rivet clip in each of the internal support walls for accepting and securing a rivet of a wiper blade, thereby securing the connector to the wiper blade. In some of these embodiments, the connector may be capable of being secured to the mounting base of a windshield wiper blade assembly via the rivet through the mounting base.

In some embodiments the connector may have a proximal shelf and may be capable of connecting to a pin-type wiper arm having a horizontal extension extending from a locking arm substantially to the end of the proximal shelf, and the top surface of the connector has clearance for the horizontal extension.

5 In some of these embodiments the connector may also have internal support walls extending downward from the top surface, and substantially along the longitudinal length of the connector. In some embodiments the connector may also have at least one rivet aperture in each of the at least two opposing peripheral side walls capable of accepting a rivet of a mounting base of a wiper blade in order to secure the connector the wiper blade assembly.

10 In some embodiments the connector may be fabricated as a single piece.

In some embodiments, the top surface of the connector may also have a proximal shelf and a distal shelf; and the connector is capable of connecting to the at least one pin-type wiper arm such that a bottom side of a locking arm of the at least one pin-type windshield wiper arm rests on the distal shelf when the connector is locked to the at least one pin-type
15 windshield wiper arm. In some of these embodiments the distal shelf may be sloped.

In some embodiments, an aperture in the top surface may be positioned to be capable of receiving a locking tab of the locking arm of a pin-type windshield wiper arm when the connector is locked to the windshield wiper arm such that the connector may be prevented from sliding off of the windshield wiper arm.

20 In some embodiments the connector may also have a spacer cavity in a peripheral side wall sized to be capable of accepting a spacer of a pin-type wiper arm having a spacer.

In some embodiments a wiper blade assembly has a wiper blade and a connector capable of connecting to the wiper blade and further capable of connecting the wiper blade to at least two different pin-type wiper arms wherein each of the at least two different pin-type
25 wiper arms has a locking arm.

In some of these embodiments the at least two different pin-type wiper arms include at least one pin-type wiper arm having a locking tab extending past the arm's pin; and at least one other pin-type wiper arm having a locking tab that does not extend past the other arm's pin. In some embodiments, the at least two different pin-type wiper arms may include at least
30 one pin-type wiper arm having a spacer on the arm's pin; and at least one other pin-type wiper arm that does not have a spacer on the other arm's pin.

In some embodiments, the wiper blade assembly may have a connector that can connect to the wiper blade by passing a rivet on the wiper blade through at least two rivet passages on the connector, into at least two arcuate rivet clips on the connector. In some embodiments, the wiper blade assembly may have a connector having a peripheral wall having at least two opposing side walls, a top surface, an aperture in the top surface sized to accept a windshield wiper arm locking tab that extends from a locking arm on a windshield wiper arm. The connector's opposing peripheral side walls may each have a retaining pin aperture aligned with one another and sized to be capable of slidably accepting a retaining pin on a windshield wiper arm.

In some embodiments, a wiper blade assembly may have a wiper blade having a rivet and a connector having a peripheral wall having two opposing side walls, a spacer cavity in at least one of the two opposing side walls, a top surface having a flat distal shelf and a sloped proximal shelf, a locking aperture capable of receiving the locking tab of a pin-type wiper arm, at least two internal support walls, each of the two internal support walls having a rivet passage and an arcuate rivet clip, a retaining pin aperture extending through the two opposing side walls and the two internal support walls, and a width between the opposing side walls of the peripheral wall that is different at the proximal shelf than the width between the opposing side walls at the distal shelf.

The connector **1** is preferably configured with a side-to-side aperture (**15a, 15b, 15c, 15d**) to accommodate a retaining pin **22**. Depending on the arms desired to be accommodated by the connector, the aperture **15** need not extend completely through the connector. However for greater wiper arm coverage, it is preferred that the aperture **15** go through both sides of the connector **1**. In addition, the top surface of the connector may provide one or more apertures **7** and an outside edge to accommodate locking tabs **24** on the locking arms **21** of the varying sizes and configurations of pin-type windshield wiper arms.

In addition, the connector is configured such that the orientation of either the windshield wiper or the connector can be reversed based on the particular windshield wiper arm that is being used.

Figure 1 is a top view of a preferred embodiment of the connector **1**. The connector **1** has a distal end **2**, and a proximal end **3**. A peripheral wall **4** extends around the periphery of connector **1**. The peripheral wall **4** including a proximal portion, a distal portion, and opposing side portions that connect the proximal and distal portions, referred to as a first side

17 and a second side **18**. A top surface extends between opposing peripheral wall side portions. Also shown on the top surface are recessed distal shelf **12** and sloped proximal shelf **13** that defines a locking aperture **7**. The other apertures (**5-6** and **8-11**) provide access for slides used in the molding process and may not perform any function when used to secure a wiper arm to the connector **1**. However, as new wiper arms are developed with locking arms of various sizes and shapes, one of skill in the art will recognize that these other apertures, **5-6** and **8** in particular, could be adapted to be additional locking apertures for new arms.

Those skilled in the art will recognize that connector **1** can be fabricated from any suitable material known in the art, including without limitation, rigid or elastic plastics, metals, synthetic and natural rubber compounds, etc.. However, certain embodiments contemplate materials that can be molded such that connector **1** is fabricated as a single piece.

Figure 2 is a bottom view of a preferred embodiment of the connector **1** that illustrates the internal support structure inside the connector **1**. In particular, internal support walls **28** provide rigidity and structural strength to the connector **1**. The support walls can extend substantially along the length of the connector continuously, or intermittently, having gaps along the way. In this embodiment, the second side **18** of the connector **1** has a spacer cavity **14** which can accommodate a spacer **25** present in certain wiper arms. Some embodiments may have not have a spacer cavity **14**, while others may have one on both sides of the connector **1**. Still other connectors may have nested spacer cavities **14** of differing sizes on the same side of the connector **1** at the same retaining pin aperture **15**. It will be appreciated that the details of whether to have and where to put spacer cavities **14** will depend on the particular arms that an embodiment of the invention is designed to accommodate. Additionally, the second side **18** is shaped such that the width of the connector at the distal shelf **12** is greater than the width of the connector at the proximal shelf **13**. Similarly, the width of the connector at each shelf **12**, **13**, and the location and shape of the various apertures, particularly apertures **5-8** will be dependent on the arms that an embodiment seeks to accommodate.

Figure 2A is a section view along the line A-A of figure 2, which shows the support wall **28** nearer to the second side **18** of the connector. As illustrated, the support wall **28** may have a retaining pin aperture **15c** for the retaining pin **22** of a pin-type wiper arm, and a rivet passage **19** that allows a rivet on the wiper blade to pass into an arcuate rivet clip (**16c**) which secures the connector **1** to the rivet of the wiper blade. Similarly, the support wall **28** nearer

to the first side **17** of the connector **1** (not shown) may also have a pin aperture **15b**, a rivet passage **19**, and an arcuate rivet clip **16b**. In addition to internal support walls **28**, peripheral wall **4** also provide rigidity and strength to the connector **1**. Other methods for connecting the connector **1** to the wiper blade known in the art are contemplated within the scope of the present invention, including having pin passages and pin clips which connect to one or more pins in the wiper blade; having one or more detents in the connector which engage shoulders in apertures or recesses in the wiper blade; having recesses in the peripheral wall of the connector that can accept and secure a rivet or pin; having deflectable or rigid pins or detents in the connector, which engage corresponding recesses, apertures or shoulders in the wiper blade; and other form-fitting or friction fitting connections and the like.

Figure 3 is a side view of a preferred embodiment of a first side **17** of the connector **1**. This figure also illustrates distal shelf **12** and proximal shelf **13**. Retaining pin aperture **15a** is shown aligned with retaining pin aperture **15d** on second side **18** (shown in figure 4), and with the retaining pin apertures **15b** and **15c** in the internal support walls **28**. Retaining pin apertures (**15a-d**) are sized to snugly fit retaining pins on windshield wiper arms (windshield wiper arms are illustrated in figures 7-9). In certain embodiments, rivet apertures **16a** and **16d** (shown in Figure 4) may be included, and are aligned with the arcuate rivet clips (**16b**, **16c**) in the support walls **28**. Alternatively, some embodiments may not include such apertures, while other embodiments may have recesses in the corresponding internal portion of the perimeter wall **4**. In order to accommodate retaining pins of different sizes, some embodiments may have additional retaining pin apertures, either next to the first retaining pin aperture **15**, or on the opposite side of the rivet aperture **16**. The retaining pin aperture **15** may also be embodied as a flexible retaining pin clip which can accommodate more than one size of pin, depending upon the types of arms and the sizes of the pins that any particular embodiment seeks to accommodate.

Figure 4 is a side view of a preferred embodiment of a second side **18** of the connector **1**. As shown, retaining pin aperture **15d** is aligned with retaining pin aperture **15a** on first side **17**, as well as retaining pin apertures **15b** and **15c** in the internal support walls **28**. Likewise, rivet aperture **16d** is aligned with rivet aperture **16a**, and with the arcuate rivet clips **16b** and **16c** in the internal support walls **28**.

Figure 6 is distal end view of a preferred embodiment of the connector **1** that illustrates distal end **2**. Those skilled in the art will recognize that the shape of distal end **2** can vary so long as it does not interfere with attachment of the connector **1** to the wiper arm.

Figure 7 is a proximal end view of a preferred embodiment of the connector **1** that illustrates proximal end **2**. Also shown in this figure is locking arm aperture **7** on proximal shelf **13**.

Figure 8 is a top view of a first prior art windshield wiper arm that illustrates the support arm **23**, the locking arm **21**, and the retaining pin **22**. In certain embodiments of the connector, the retaining pin apertures **15a-d** in the connector **1** are sized to snugly fit the retaining pin **22**. When the wiper blade is slipped over the retaining pin and turned to the secured and locked position, proximal shelf **12** of connector **1** will rest against the bottom side of the locking arm **21** and locking tab **24** will extend over the peripheral wall **4** on the second side **18** of the connector **1** to prevent connector **1** from sliding off of the retaining pin **22**.

Figure 9 is a distal end view of the wiper arm of Figure 8 that illustrates the support arm **23**, the locking arm **21**, and the locking tab **24** in relation to the retaining pin **22**. As shown in this figure, support arm **23** securely holds retaining pin **22** and maintains it in the proper orientation. The particular wiper arm shown in this figure has a locking arm **21** that extends beyond the end of the retaining pin **22**.

Figure 10 is a proximal end view of the preferred embodiment of the connector connecting to the wiper arm of figure 8 (shown in top view), illustrating the connector **1** slipped over the retaining pin **22** in the attachment position, prior to being rotated into the secured and locked position. In the attachment position, support arm **23** may be substantially perpendicular to connector **1**, though attachment at other angles is also possible. This allows the retaining pin **22** to be inserted through retaining pin aperture **15a-d** without interference from locking arm **21** and locking tab **24**.

Figure 11 is a top view of an embodiment of the connector **1** connected to the wiper arm of Figure 8, illustrating the connector **1** secured to the windshield wiper arm with the connector in the secured and locked position. In this figure, connector **1** and the wiper blade (not shown) has been rotated about retaining pin **22** until distal shelf **12** of connector **1** comes to rest on the bottom side of locking arm **21**. In this position, locking tab **24** is adjacent to the second side **18** of connector **1** thereby preventing connector **1** from sliding off of the retaining pin **22**. In this embodiment, the width of the connector **1** at the distal shelf is sized to properly fit the width of the locking arm **21** of the wiper arm such that the locking tab **24** rests against the outer surface of the peripheral wall **4** near the distal shelf **12**.

Figure 12 is a top view of a second prior art windshield wiper arm that illustrates the support arm **23**, the locking arm **21**, and the retaining pin **22**. This embodiment differs from the embodiment illustrated in Figures 8-11 in that the locking arm **21** is shorter than retaining pin **22**. As a result, locking tab **24** will not rest against the outer peripheral wall **4** of connector **1**. Rather, it will extend through aperture **7** on the connector **1**.

Figure 13 is a distal end view of the wiper arm of Figure 12 that illustrates the support arm **23**, the locking arm **21**, and the locking tab **24** in relation to the retaining pin **22**. As can be seen from this figure, retaining pin **22** extends past locking arm **21** and locking tab **24**. Further, this figure illustrates a new element, spacer **25**, which is intended to rest inside spacer cavity **14** (illustrated above in figure 2).

Figure 14 is a distal end view of a preferred embodiment of the connector **1** connected to the wiper arm of figure 12 (shown in top view) illustrating the connector **1** slipped over the retaining pin **22** in the attachment position prior to being rotated into the secured and locked position. As mentioned above, spacer **25** rests inside spacer cavity **14**.

Figure 15 is a top view of an embodiment of the connector **1** illustrating the connector **1** in its secured and locked position relative to the windshield wiper arm of Figure 12. In this embodiment, the connector **1** is reversed such that the proximal shelf **13** comes to rest against the bottom side of locking arm **21**. Also illustrated in this figure is the use of locking aperture **7** to accommodate locking tab **24**. This prevents the connector **1** from sliding off of the retaining pin **22** during use. In this particular embodiment, the proximal shelf has been implemented at an angle relative to the surface of the connector in order to allow this particular arm to have a negative angle relative to the wiper blade to improve performance. The angle at which the proximal shelf **13** is designed will depend on the characteristics of the particular arm sought to be accommodated, and the proximal shelf **13** may be provided with no angle at all, or with a shallower or steeper angle than the one depicted. Similarly, in certain embodiments it may be necessary to provide the distal shelf with an angle to provide an appropriate wipe angle for a particular wiper arm.

Figure 16 is a top view of another prior art a windshield wiper arm that illustrates the support arm **23**, the locking arm **21**, and the retaining pin **22**. This embodiment illustrates an alternative configuration for locking arm **21**. In this configuration, the locking arm **21** has a horizontal extension **29**.

Figure 17 is a distal end view of the wiper arm of Figure 16 that illustrates the support arm **23**, the locking arm **21**, and the locking tab **24** in relation to the retaining pin **22**. In this embodiment, the locking arm **21** extends past the end of the retaining pin **22**.

Figure 18 is a proximal end view of an embodiment of the connector connecting to the wiper arm of Figure 16 illustrating the connector **1** engaging the retaining pin **22** in the attachment position prior to being rotated into the secured and locked position. As was the case in the previous embodiments, the connector **1** is positioned to allow it to slide onto retaining pin **22** without interference from locking arm **21** or locking tab **24**.

Figure 19 is a top view of the embodiment of the connector **1** connected to the wiper arm of Figure 16 illustrating the connector **1** secured to the windshield wiper arm with the connector **1** in the locked position. In this position, the wiper blade (not shown) has been rotated about retaining pin **22** until distal shelf **12** of connector **1** comes to rest against the bottom side of horizontal extension **29** of locking arm **21**. In this position, locking tab **24** is adjacent to side **18** of connector **1**. This prevents connector **1** from sliding off of the retaining pin **22**. In certain wiper arms similar to this one, there may be a second locking tab extending from the horizontal extension **29**, or the locking arm **21** may be sized shorter than the pin such that the locking tab does not reach the outside surface of the peripheral wall **4** of the connector. To accommodate such variances in the wiper arm, the apertures on the surface, particularly **5, 6 and 8**, can be modified and shaped to handle such occurrences.

As can be seen from Figures 8-11 and 16-19, the same connector **1** can be used with differing windshield wiper arms. This allows a reduced inventory that can satisfy the needs of a larger number of windshield wiper arm types.

Figures 10-14 show another embodiment of the connector **101**. The distinguishing characteristic of this embodiment is that the surfaces of the connector **101** have been shortened and leveled. Thus, instead of having a recessed distal shelf, this embodiment has a flat, non-recessed distal shelf **112**. Likewise, this embodiment of the connector **101** has a sloped, non-recessed proximal shelf **113**. Figures 20 and 21 show perspective views of this embodiment.

Figure 22 shows a top view of another embodiment of the connector. Comparing the apertures on the top surface of the embodiment in Figure 1 to the apertures on the top surface of the embodiment in Figure 22 is exemplary of the variation possible with the shape and location of the apertures on the top surface of the connector **1, 101**. Like the first

embodiment, the connector **101** has a distal end **102** and a proximal end **103**, a peripheral wall **104**, non-locking apertures **105, 106 and 110**, a locking aperture **107**, a distal shelf **112**, and a proximal shelf **113**. The width of the connector at the distal shelf **112** and at the proximal shelf **113**, and the positioning of the locking aperture **107** are dependent on the arms that are intended to be accommodated. This embodiment can connect to the same wiper arms to which the first embodiment of connector **1** could connect.

Figure 23 shows a bottom view of another embodiment of the connector, showing the internal support structures contained therein. Internal support walls **128** provide rigidity and structural strength to the connector **101**. Likewise, the second side **118** of the connector **101** is provided with a spacer cavity **114** for receiving a spacer **25** of a wiper arm similar to that depicted in Figure 12.

Figures 24 and 26 illustrate side views of the first side **117** and second side **118**. Likewise, Figures 25 and 27 show a cross-sectional view of the internal support walls **128** near the first side **117** and second side **118**, respectively. As with the first embodiment, the retaining pin apertures **115a-d** are aligned with one another, and are sized to fit the retaining pin **22** of the pin-type wiper arms. Similarly, the rivet apertures **16a** and **16d**, and the arcuate rivet clips **16b** and **16c**, are aligned with one another. The internal support walls **128** have rivet passages **119** allowing the connector to connect securely to a wiper blade having a rivet. Of course, other methods of connecting the connector to a wiper blade are within the scope of the invention. Figures 24 and B and 26 and B illustrate the shorter, flat top surface of the connector, having sides sloping downward on each side of the rivet. Reducing the height of the connector makes it require less material (and thus makes it less expensive), gives it a lower profile for the purposes of the connector's effect on the passage of air over the windshield, and the more symmetric look allows the connector to be rotated as needed while maintaining the same aesthetic look. As before the sloped proximal shelf **113** allows an arm connecting to it to maintain a negative angle between the wiper arm and the wiper blade, and the spacer cavity **114** in the second side **118** of the connector **101** allows the connector **101** to connect a pin-type wiper blade to a wiper arm having a spacer **25**.

In operation, the windshield wiper connector **1** disclosed by this invention allows a single windshield wiper to be used in conjunction with windshield wiper arms having a wide variety of configurations. This reduces manufacturing cost, inventory cost, and provides for easy replacement of windshield wipers as needed.

Another embodiment of the invention is a wiper blade provided with a connector **1** and **101** as described above, or as shown in Figures 1-27. The wiper blade may be of any type suitable for use with the present invention. For example, the wiper blade can be a traditional wiper blade having a plurality of frames which carry a wiper strip, and having a mounting base. Alternatively, the wiper blade may be a beam blade, having one or more spring-elastic beams, a wiper strip, and a mounting base. The wiper blade may also be a hybrid wiper blade, which has a combination of a beam and one or more frames, a wiper strip, and a mounting base. Regardless of the type of wiper blade, the connector **1**, **101** can be adapted to connect to the wiper blade, for example, via a rivet on the wiper blade (which is commonly located in a mounting base or in the frame of the wiper blade) and a rivet passage **19** and arcuate rivet clips **16b**, **16c** on the connector **1**, **101**. Any other method discussed above or otherwise known in the art would also be suitable, such as having one or more pins, holes, recesses, channels, or other structure in the wiper blade, and having corresponding pin clips, detents or pins or any other structure complimentary to the structure in the connector **1**, **101**.

In certain embodiments, the connector **1**, **101** may be connected to the wiper blade prior to connecting to the wiper arm. In certain embodiments, the connector **1**, **101** may be connected to the wiper arm prior to being connected to the wiper blade.. In certain embodiments, the connector **1** may either be first connected to the wiper arm or to the wiper arm.

Those skilled in the art will recognize that while the invention will most likely be used in conjunction with automobiles, it is suitable for use with any vehicle. For example, in addition to automobiles, trucks, buses, locomotives, aircrafts, or any other vehicle type that uses a windshield wiper can benefit from the invention.

While specific embodiments have been discussed to illustrate the invention, it will be understood by those skilled in the art that the descriptions herein are intended as illustrative, and not as limiting, and that variations in the embodiments can be made without departing from the spirit of the invention.

For example, any suitable material can be used to manufacture the connector. The number or position of the retaining pin apertures, locking apertures, or other mechanisms can vary so long as they are capable of performing their intended function.

WHAT IS CLAIMED IS:

1. A connector for connecting a windshield wiper assembly to at least one pin-type wiper arm, comprising:

5 a peripheral wall having at least two opposing peripheral side walls, each peripheral side wall having an outer surface and an inner surface, the inner surfaces facing each other; a top surface extending from one of the two opposing peripheral side walls to the other; and

10 a spacer cavity in the outer surface of one of the opposing peripheral side walls dimensioned to be capable of accepting a cylindrical spacer surrounding a base of a pin of a pin-type wiper arm,

wherein the opposing peripheral side walls each having a retaining pin aperture aligned with one another and sized to be capable of slidably accepting a retaining pin of the at least one pin-type windshield wiper arm, wherein the retaining pin aperture in the one of the opposing peripheral side walls having the spacer cavity is disposed within the spacer cavity, and

wherein a width of the spacer cavity measured across a diameter of the retaining pin aperture disposed within the spacer cavity is greater than the diameter of the retaining pin aperture.

20 2. The connector of claim 1, further comprising:

an aperture in the top surface sized such that it is capable of accepting a first locking tab that extends from a locking arm on a first pin-type of windshield wiper arm; and wherein

25 the distance between the outside surfaces of the peripheral side walls is such that the connector is capable of being attached to a second pin-type windshield wiper arm, such that a second locking arm of the second pin-type windshield wiper arm extends past the at least two opposing peripheral side walls of the connector and the locking tab extends along an outer surface of one of the at least two opposing peripheral side walls of the connector.

30

3. The connector of claim 2, wherein:
the top surface of the connector further comprises a proximal shelf and a distal shelf; and
the connector is capable of having a bottom side of the first and/or second locking arms
of the first and/or second pin-type windshield wiper arms rest on the proximal shelf
5 when the connector is locked to each of the first pin-type and second pin-type
windshield wiper arms.
4. The connector of claim 3, wherein:
the proximal shelf is recessed.
5. The connector of claim 1, further comprising:
10 at least two internal support walls, and at least one rivet passage and arcuate rivet clip in
each of the internal support walls for accepting and securing a rivet of a wiper blade,
thereby securing the connector to the wiper blade.
6. The connector of claim 5, wherein:
the connector is capable of being secured to the mounting base of a windshield wiper blade
15 assembly via the rivet through the mounting base.
7. The connector of claim 1, further comprises a distal shelf, wherein
the connector is further capable of connecting to a pin-type wiper arm having a horizontal
extension extending from a locking arm substantially to the end of the distal shelf, and
the top surface of the connector has clearance for the horizontal extension.
- 20 8. The connector of claim 1, wherein:
the connector is fabricated as a single piece.
9. The connector of claim 7, further comprising:
internal support walls extending downward from the top surface, and substantially along
the longitudinal length of the connector.
- 25 10. The connector of claim 7, further comprising:
at least one rivet aperture in each of the at least two opposing peripheral side walls capable
of accepting a rivet of a mounting base of a wiper blade in order to secure the connector
the wiper blade assembly.

11. The connector of claim 1, wherein:

the top surface of the connector further comprises a proximal shelf and a distal shelf; and
the connector is capable of connecting to the at least one pin-type wiper arm such that
a bottom side of a locking arm of the at least one pin-type windshield wiper arm rests
on the distal shelf when the connector is locked to the at least one pin-type windshield
wiper arm.

12. The connector of claim 11, wherein:

the distal shelf is sloped.

13. The connector of claim 1, wherein:

an aperture in the top surface is positioned to be capable of receiving a locking tab of the
locking arm of the at least one pin-type windshield wiper arm when the connector is
locked to the windshield wiper arm;
whereby the connector is prevented from sliding off of the at least one pin-type at least one
pin-type windshield wiper arm.

14. A wiper blade assembly comprising:

a wiper blade;

a connector capable of connecting to said wiper blade and further capable of connecting
said wiper blade to at least one type of pin-type wiper arms wherein each of the at least
two different pin-type wiper arms has a locking arm, the connector comprising

a peripheral wall having at least two opposing peripheral side walls, each peripheral
side wall having an outer surface and an inner surface, the inner surfaces facing
each other;

a top surface extending from one of the two opposing peripheral side walls to the
other; and

a spacer cavity in the outer surface of one of the opposing peripheral side walls
dimensioned to be capable of accepting a cylindrical spacer surrounding a base
of a pin of a pin-type wiper arm,

wherein the opposing peripheral side walls each having a retaining pin aperture
aligned with one another and sized to be capable of slidably accepting a
retaining pin of the at least one pin-type windshield wiper arm, wherein the

retaining pin aperture in the one of the opposing peripheral side walls having the spacer cavity is disposed within the spacer cavity, and

wherein a width of the spacer cavity measured across a diameter of the retaining pin aperture disposed within the spacer cavity is greater than the diameter of the retaining pin aperture.

5

15. The wiper blade assembly of claim 14, wherein the at least two different pin-type wiper arms comprises:

at least one pin-type wiper arm having a locking tab extending past the arm's pin; and

at least one other pin-type wiper arm having a locking tab that does not extend past the

10

other arm's pin.

16. The wiper blade assembly of claim 14, wherein the at least two different pin-type wiper arms comprises:

at least one pin-type wiper arm having a spacer on the arm's pin; and

at least one other pin-type wiper arm that does not have a spacer on the other arm's pin.

15

17. The wiper blade assembly of claim 14, wherein the connector can connect to the wiper blade by passing a rivet on the wiper blade through at least two rivet passages on the connector, into at least two arcuate rivet clips on the connector.

18. The wiper blade assembly of claim 14, wherein the connector further comprises:

a peripheral wall having at least two opposing side walls;

20

a top surface;

an aperture in the top surface sized to accept a windshield wiper arm locking tab that extends from a locking arm on a windshield wiper arm; and

the opposing peripheral side walls each having a retaining pin aperture aligned with one another and sized to be capable of slidably accepting a retaining pin on a windshield

25

wiper arm.

19. A wiper blade assembly comprising:

a wiper blade having a rivet; and

a connector having

a peripheral wall having two opposing side walls;

a spacer cavity in at least one of the two opposing side walls dimensioned to be capable of accepting a cylindrical spacer surrounding a base of a pin of a pin-type wiper arm;

5 a top surface having a flat distal shelf and a sloped proximal shelf, and a locking aperture capable of receiving the locking tab of a pin-type wiper arm;

at least two internal support walls, each of the two internal support walls having a rivet passage and an arcuate rivet clip;

a retaining pin aperture disposed within the spacer cavity and extending through the two opposing side walls and the two internal support walls; and

10 a width between the opposing side walls of the peripheral wall that is different at the proximal shelf than the width between the opposing side walls at the distal shelf;

15 wherein a width of the spacer cavity measured across a diameter of the retaining pin aperture disposed within the spacer cavity is greater than the diameter of the retaining pin aperture.

Figure 1

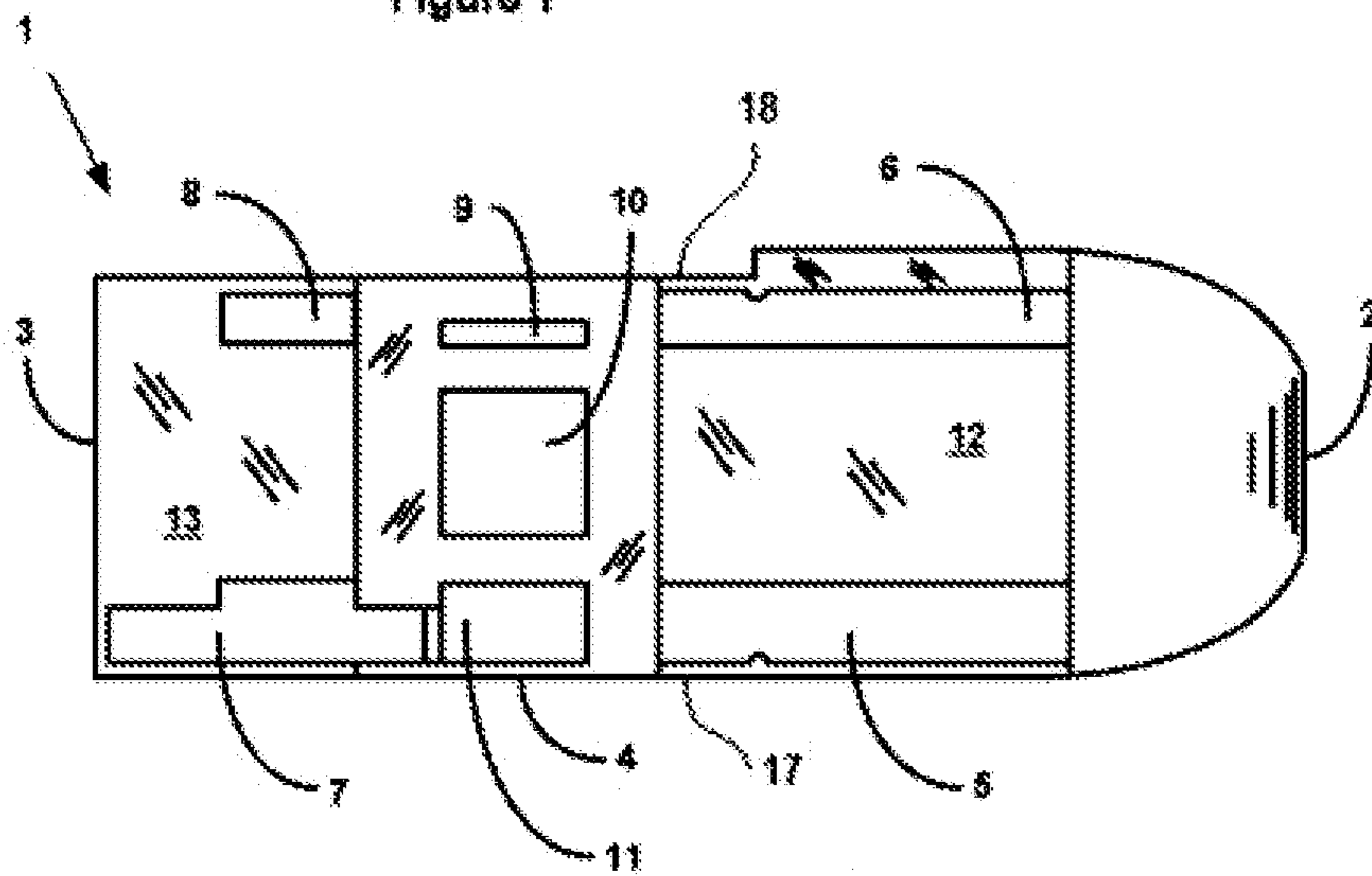

Figure 2

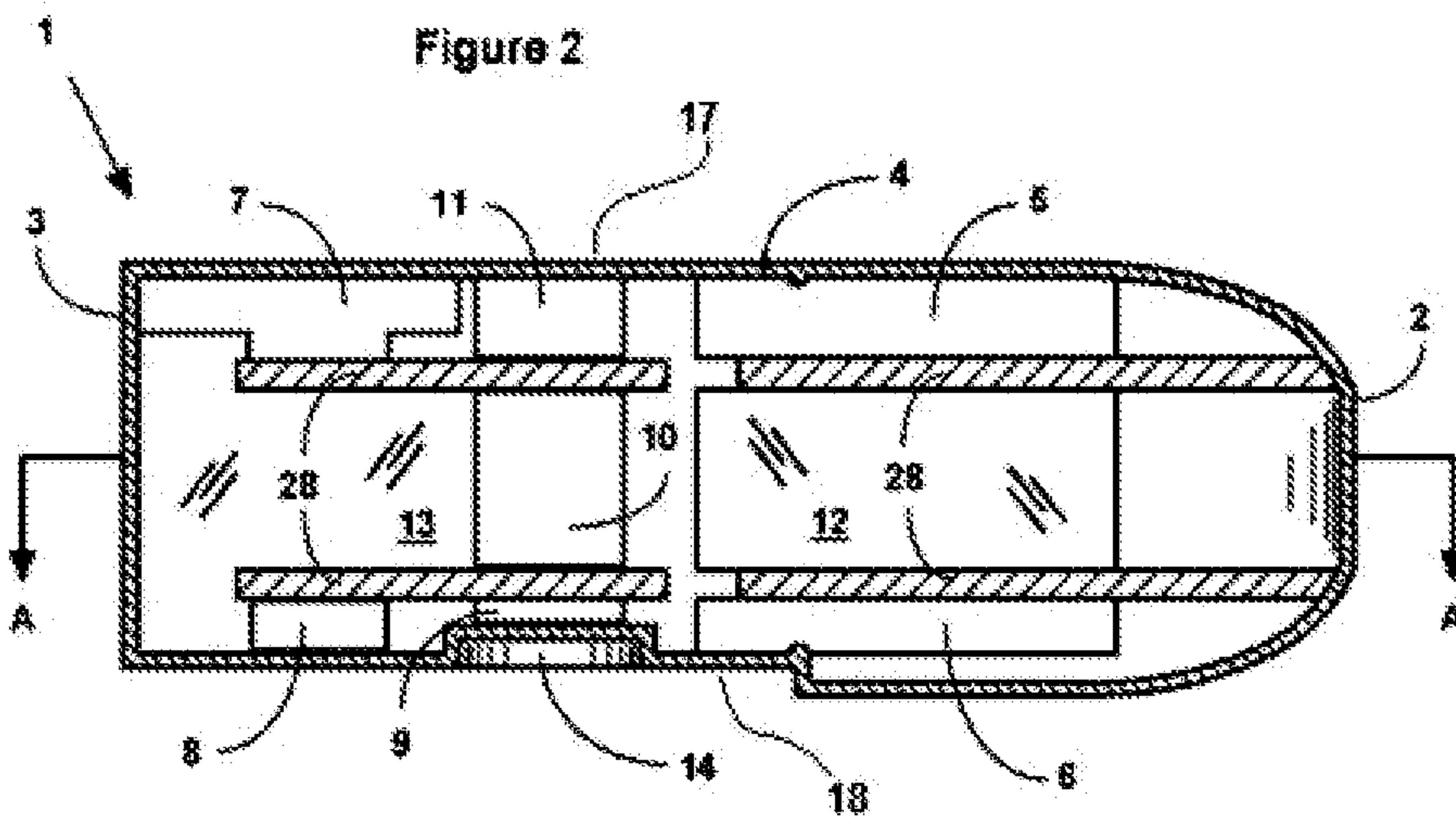

Figure 3

Section View AA

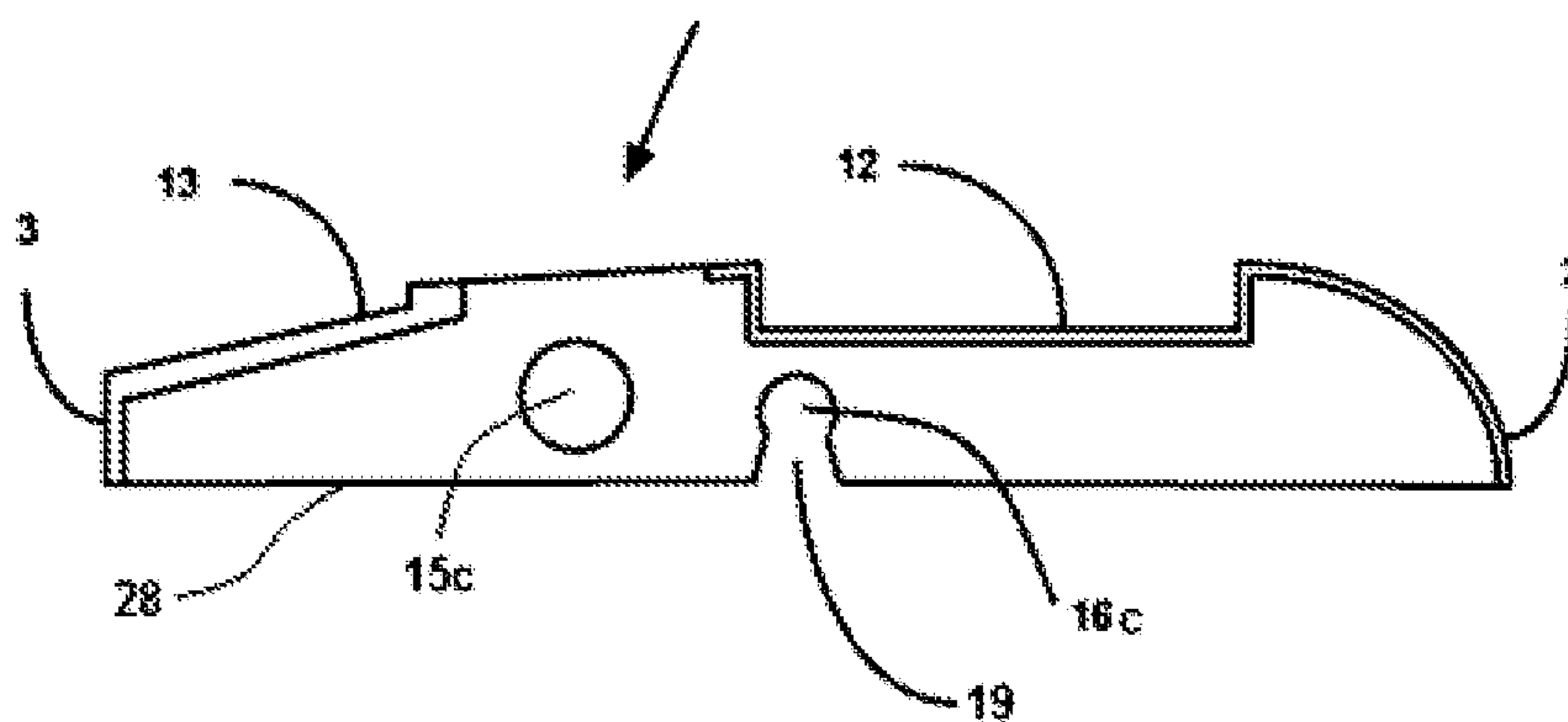

Figure 4

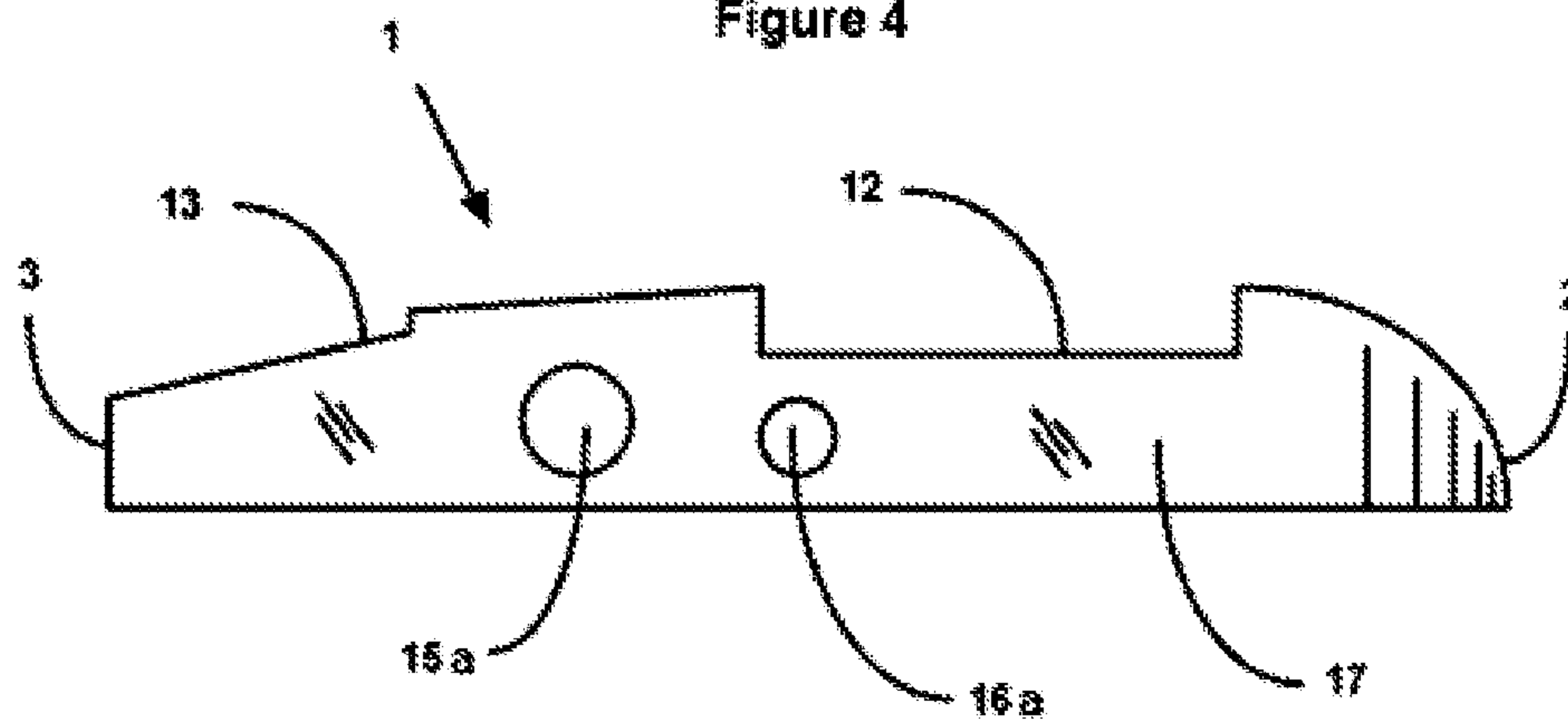

Figure 5

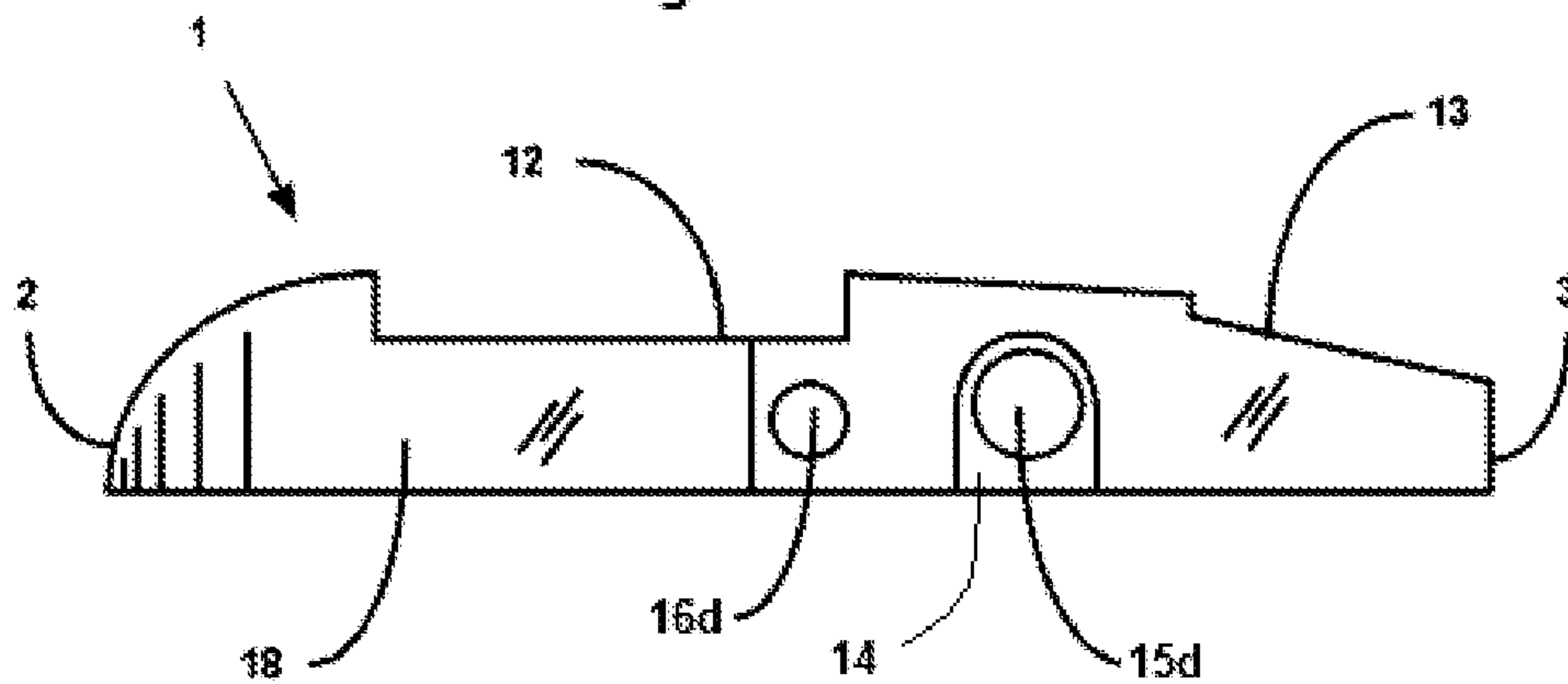

Figure 6

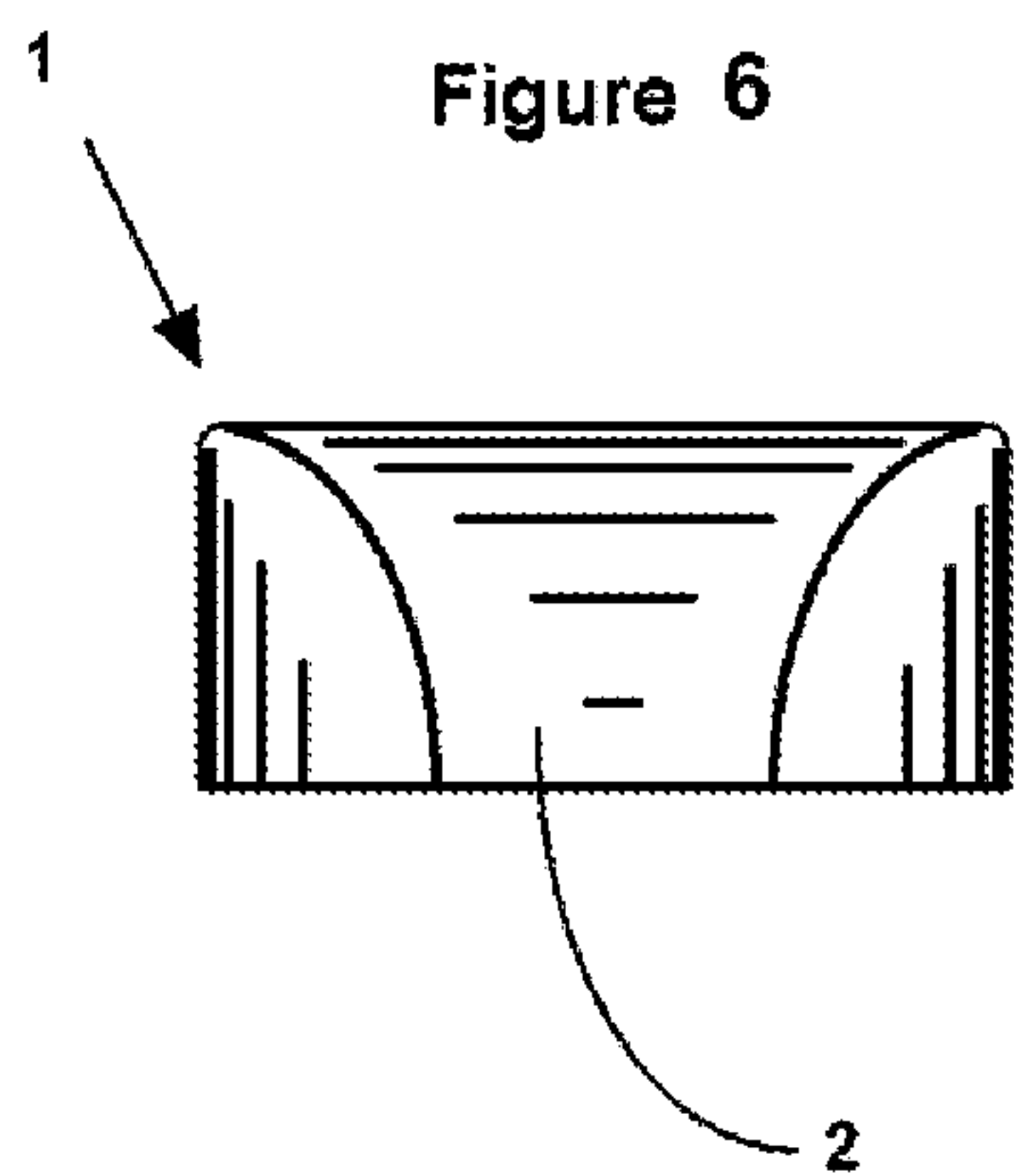
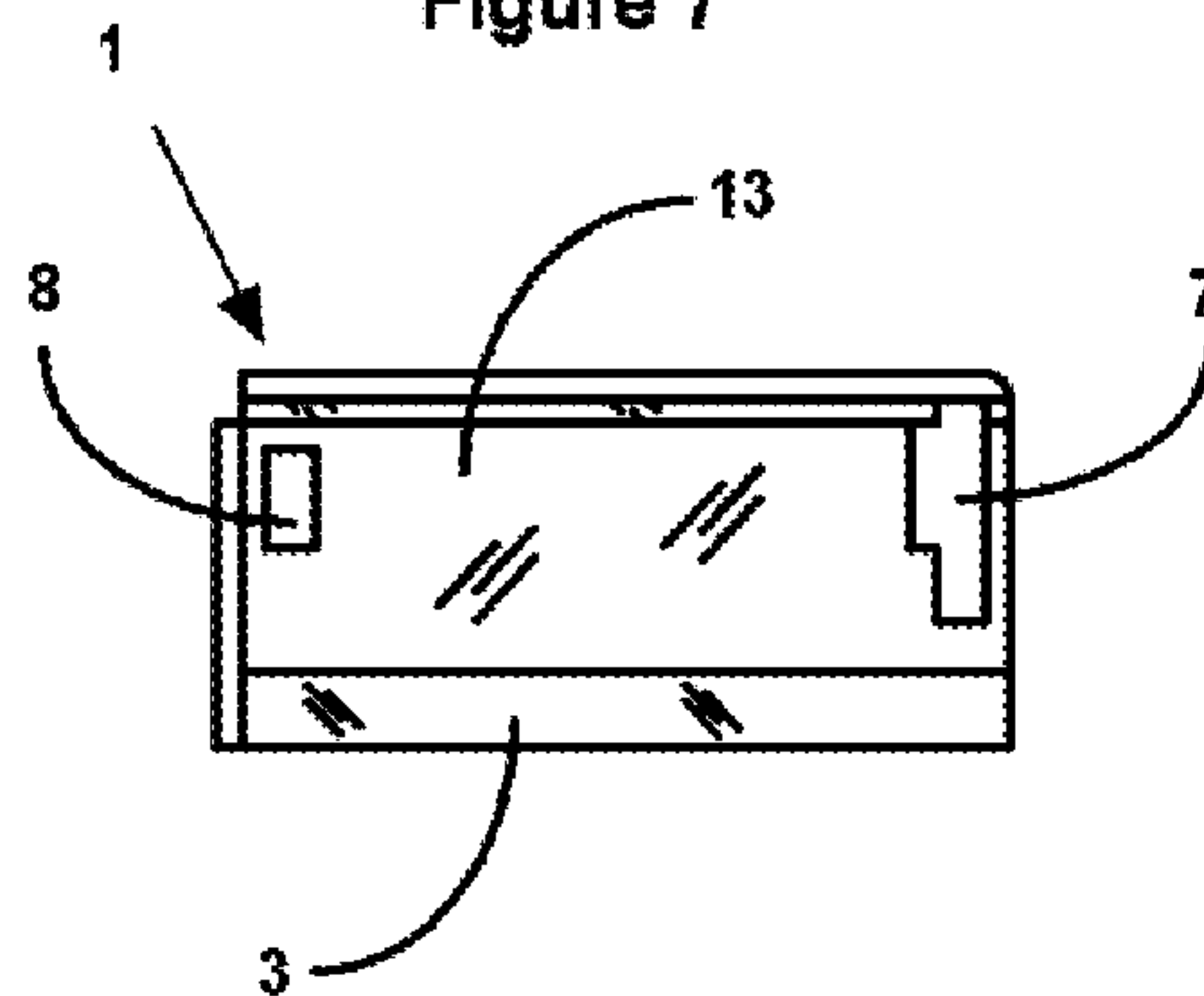
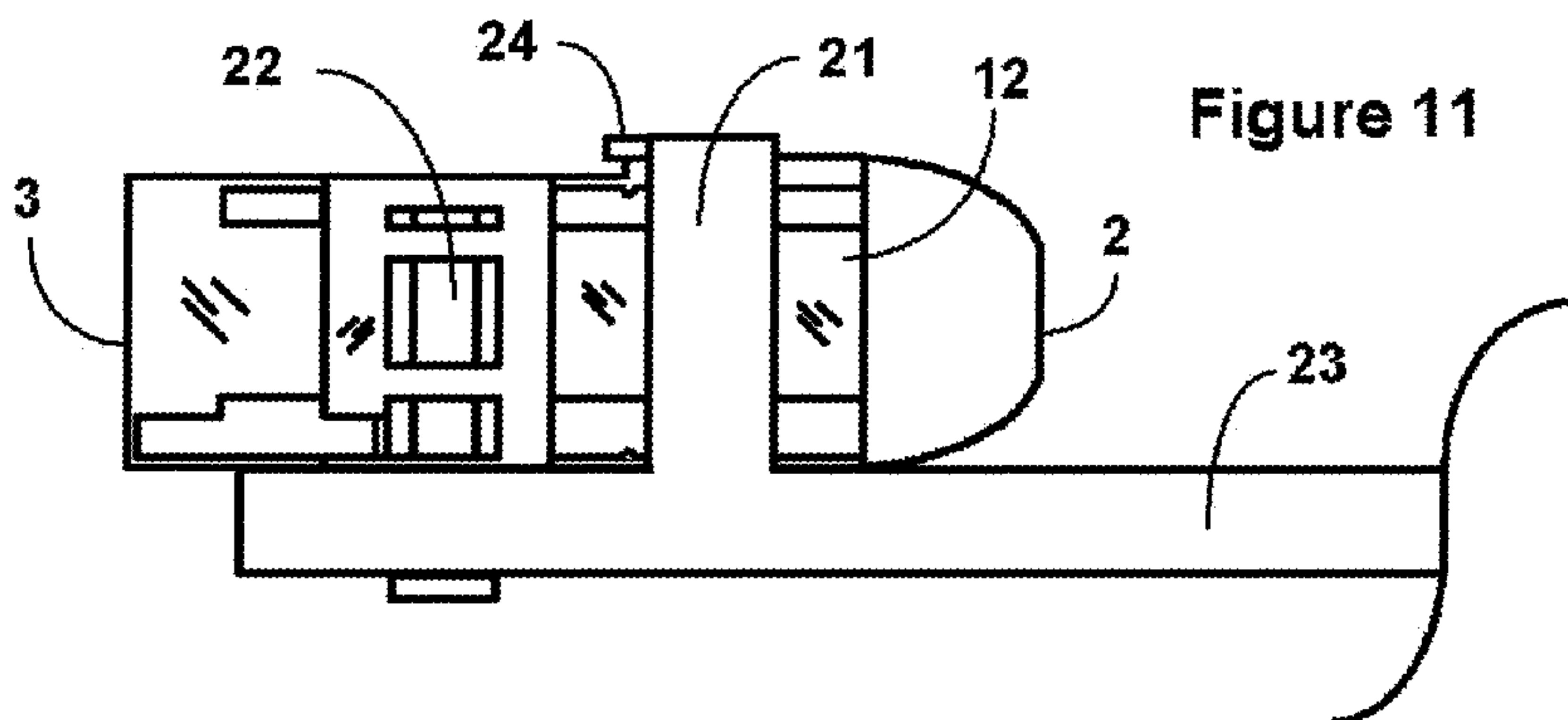
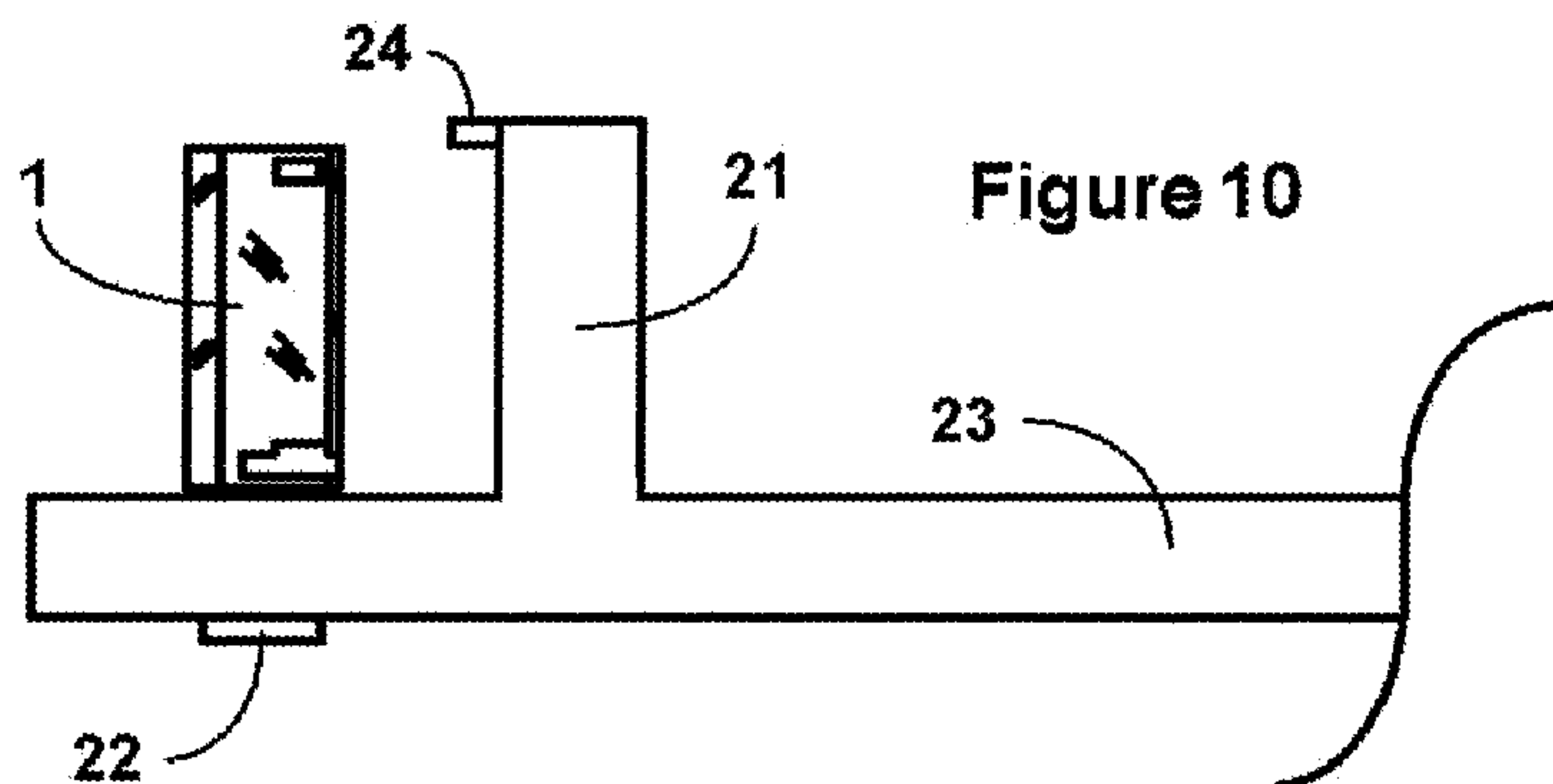
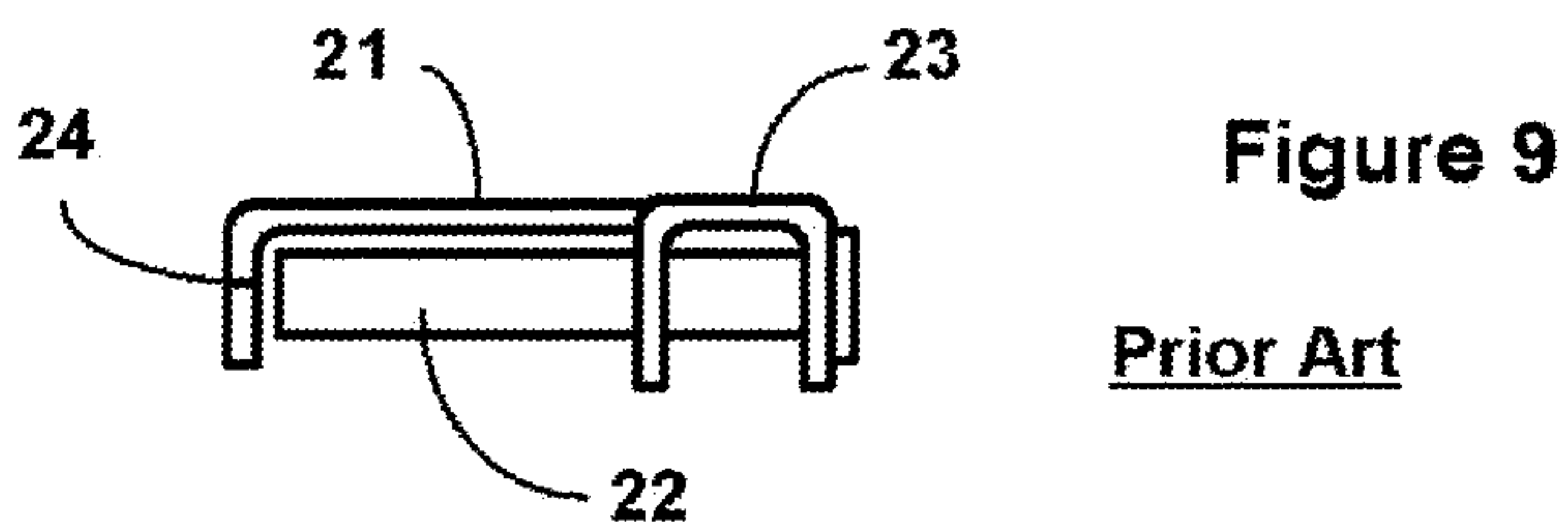
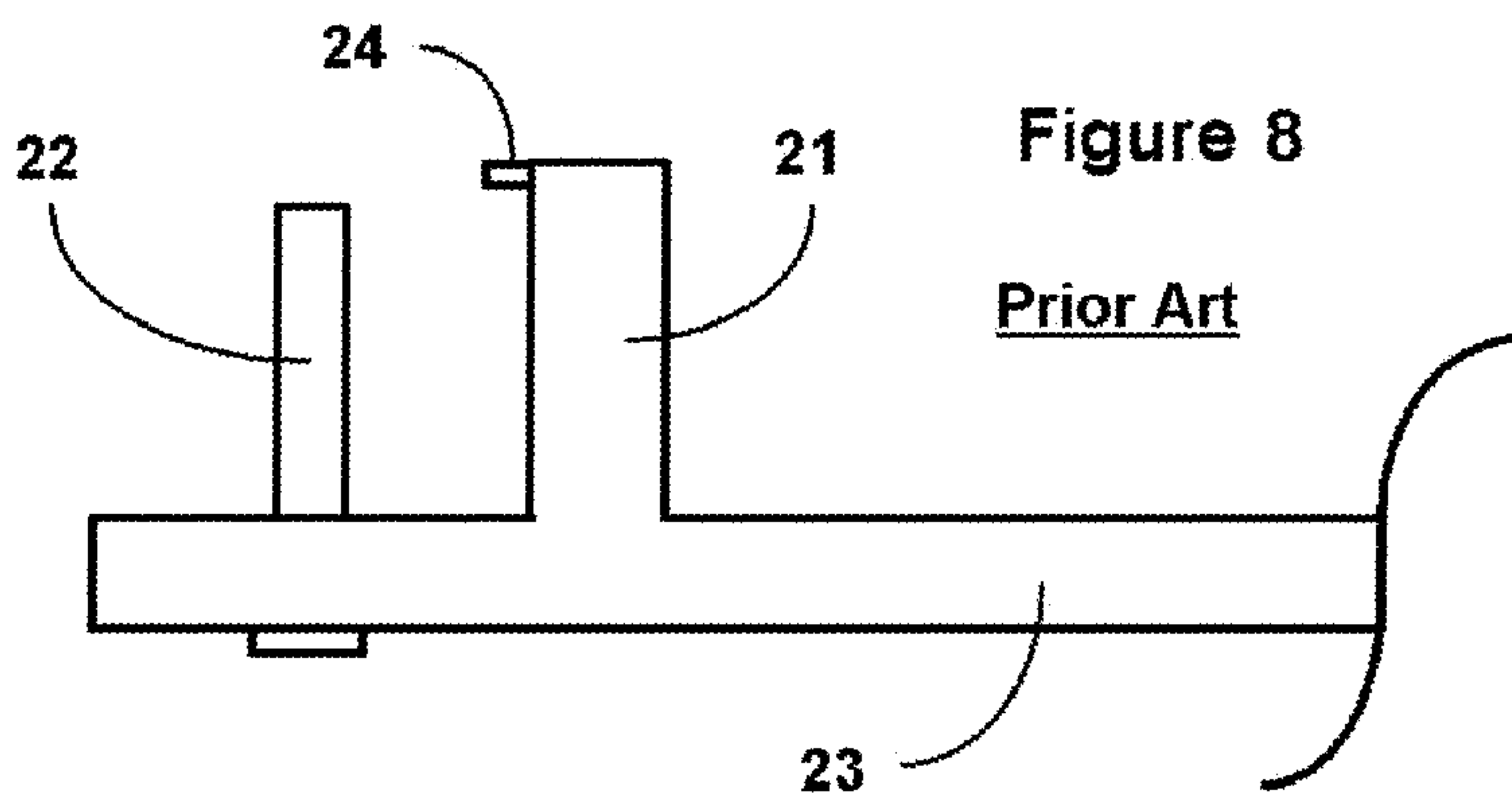
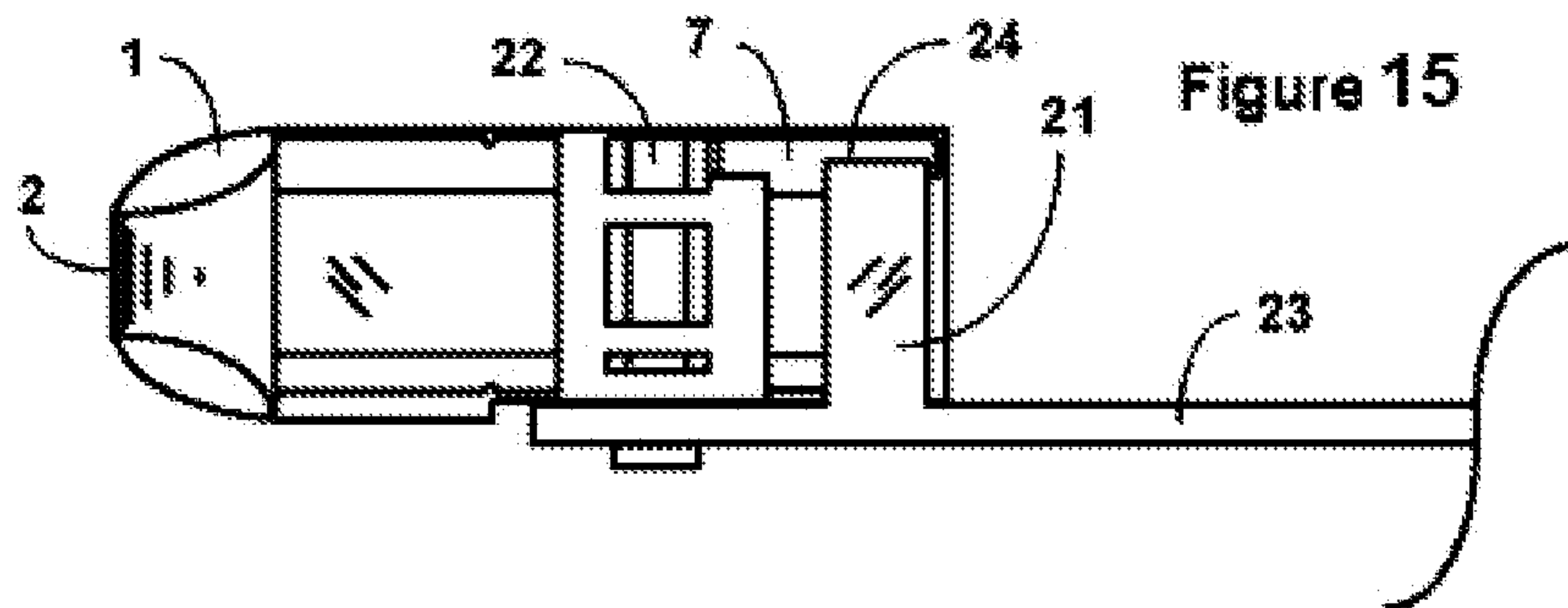
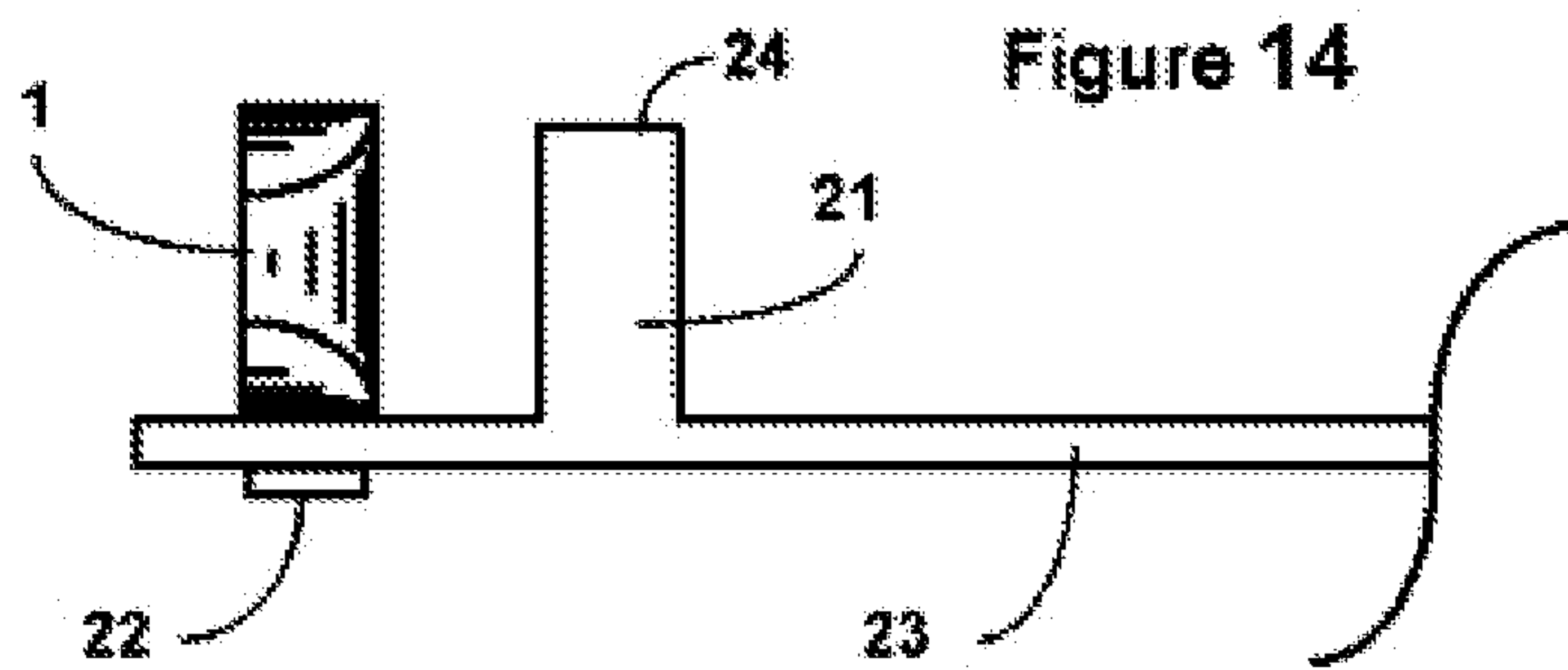
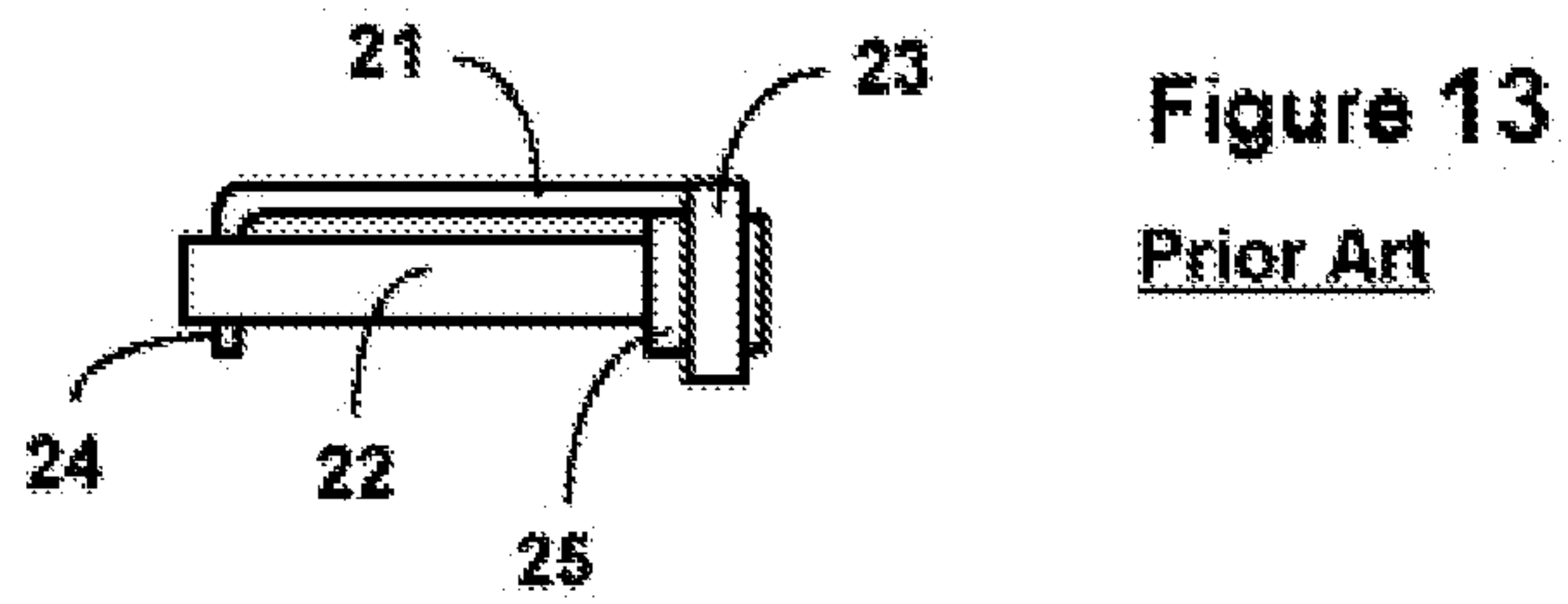
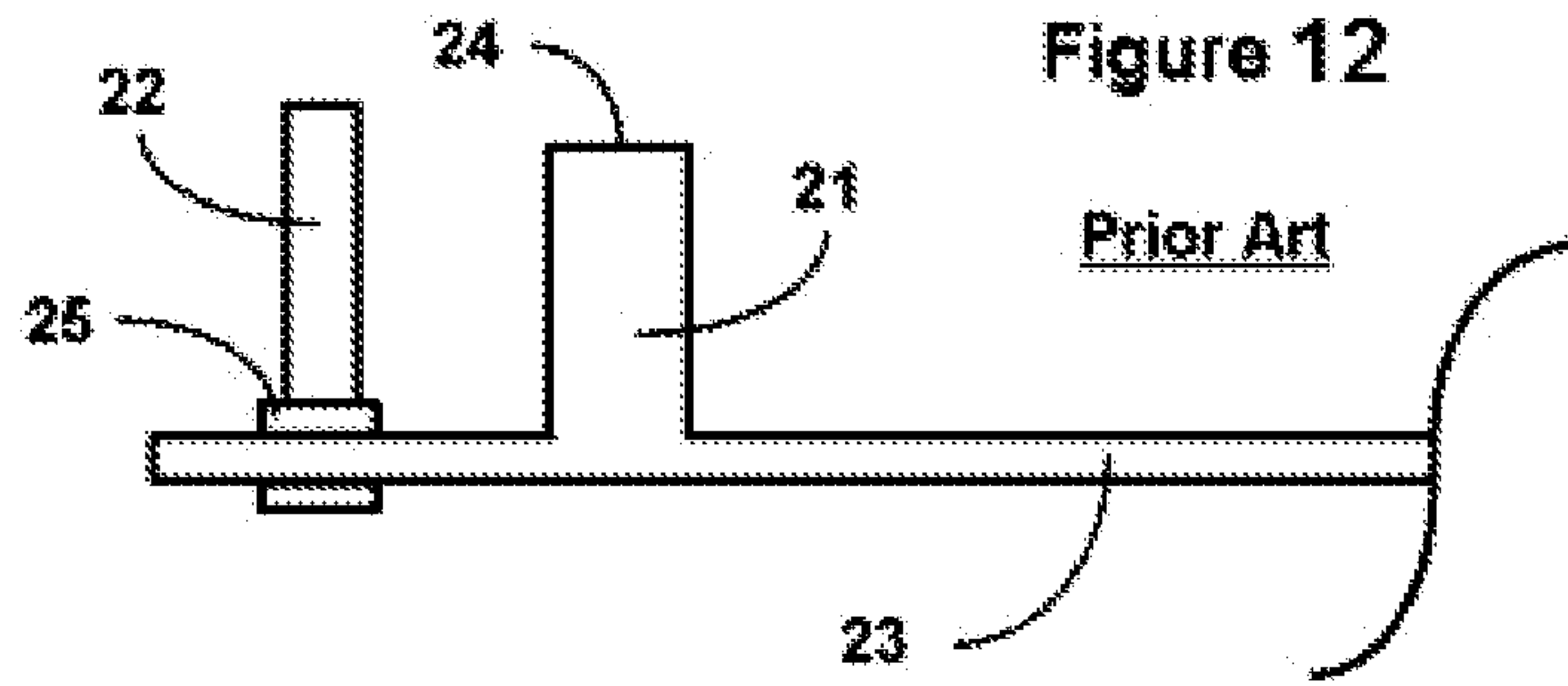

Figure 7







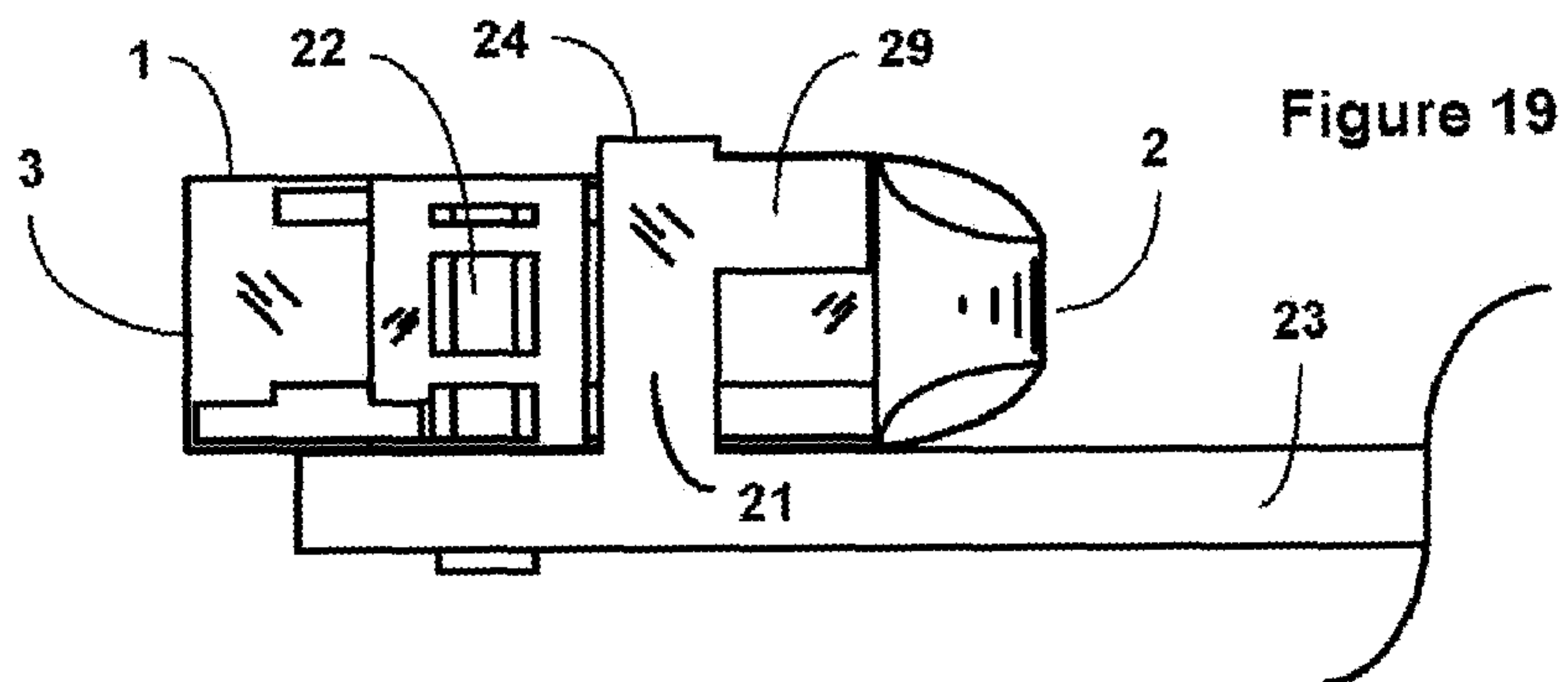
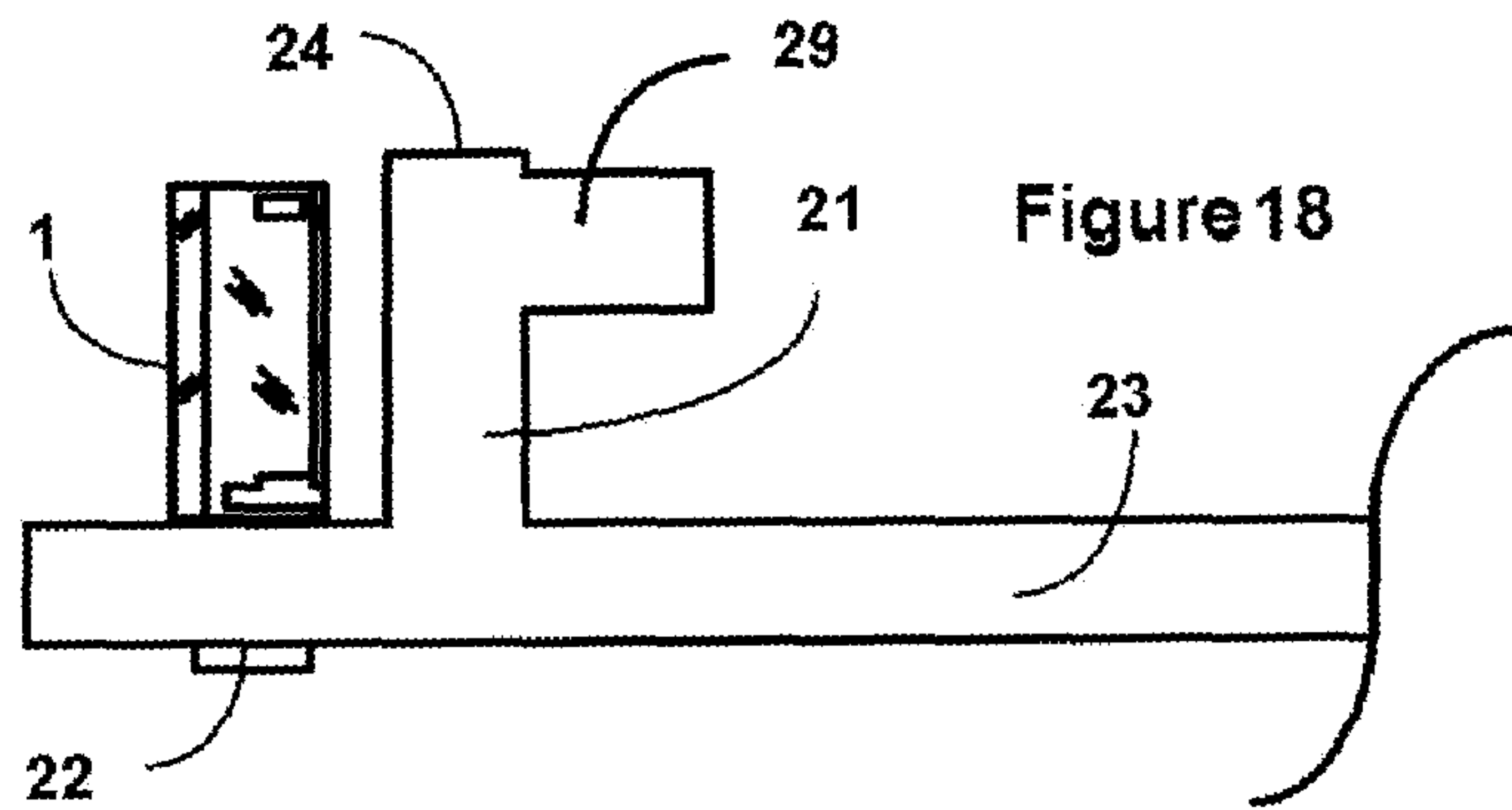
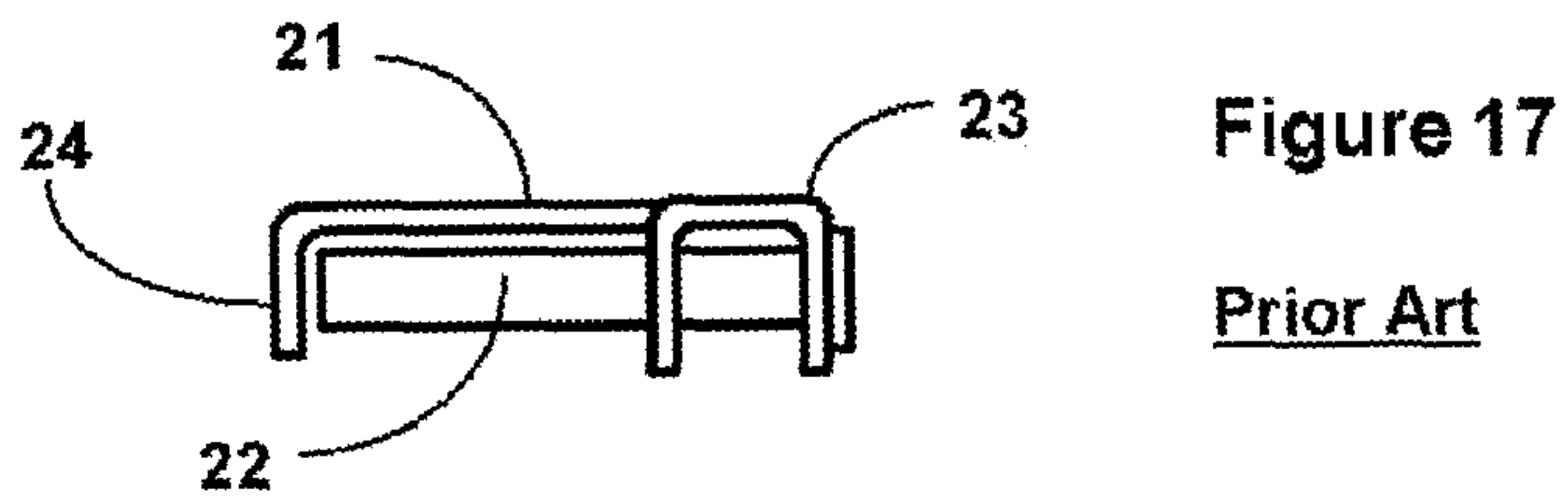
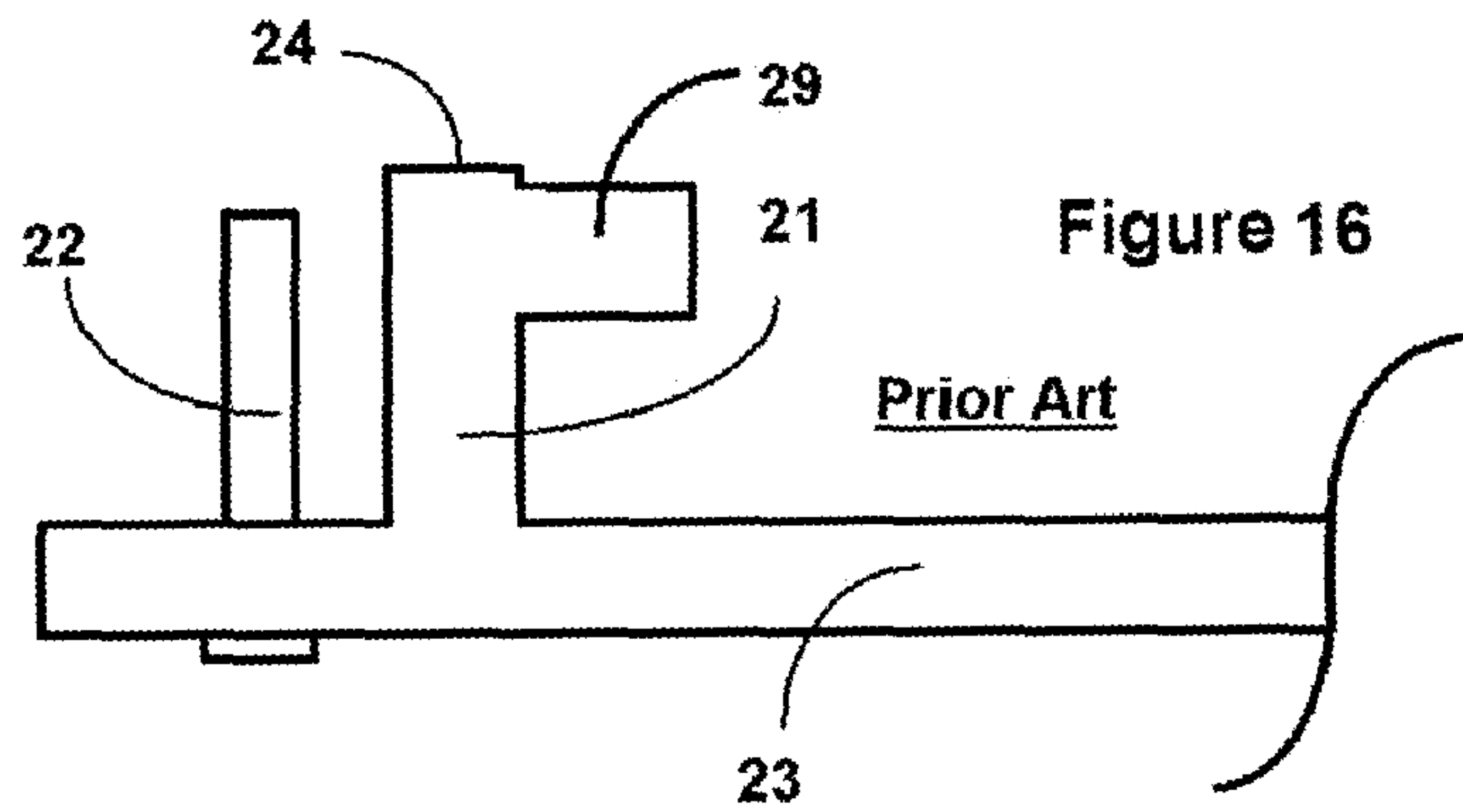

Figure 20

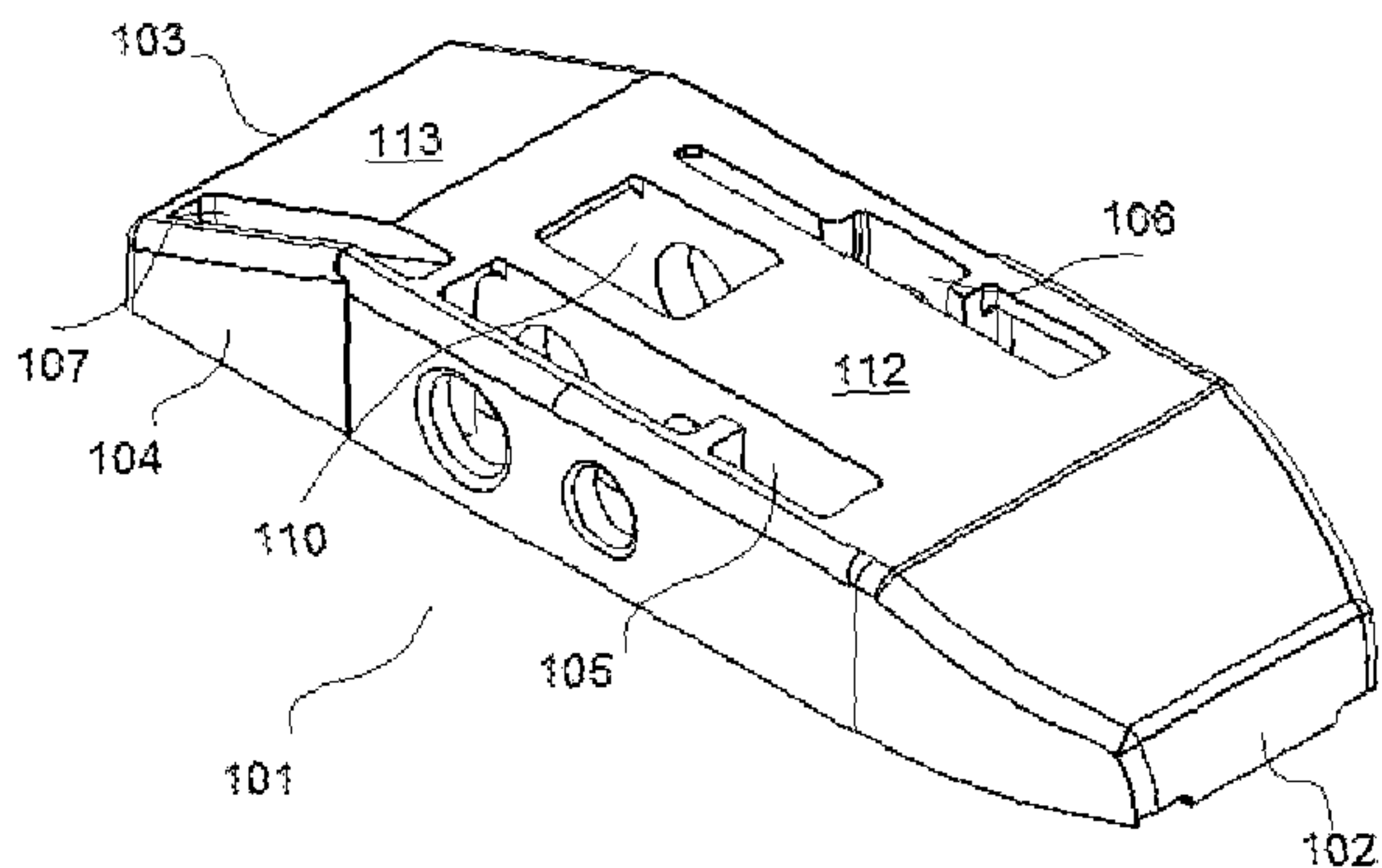

Figure 21

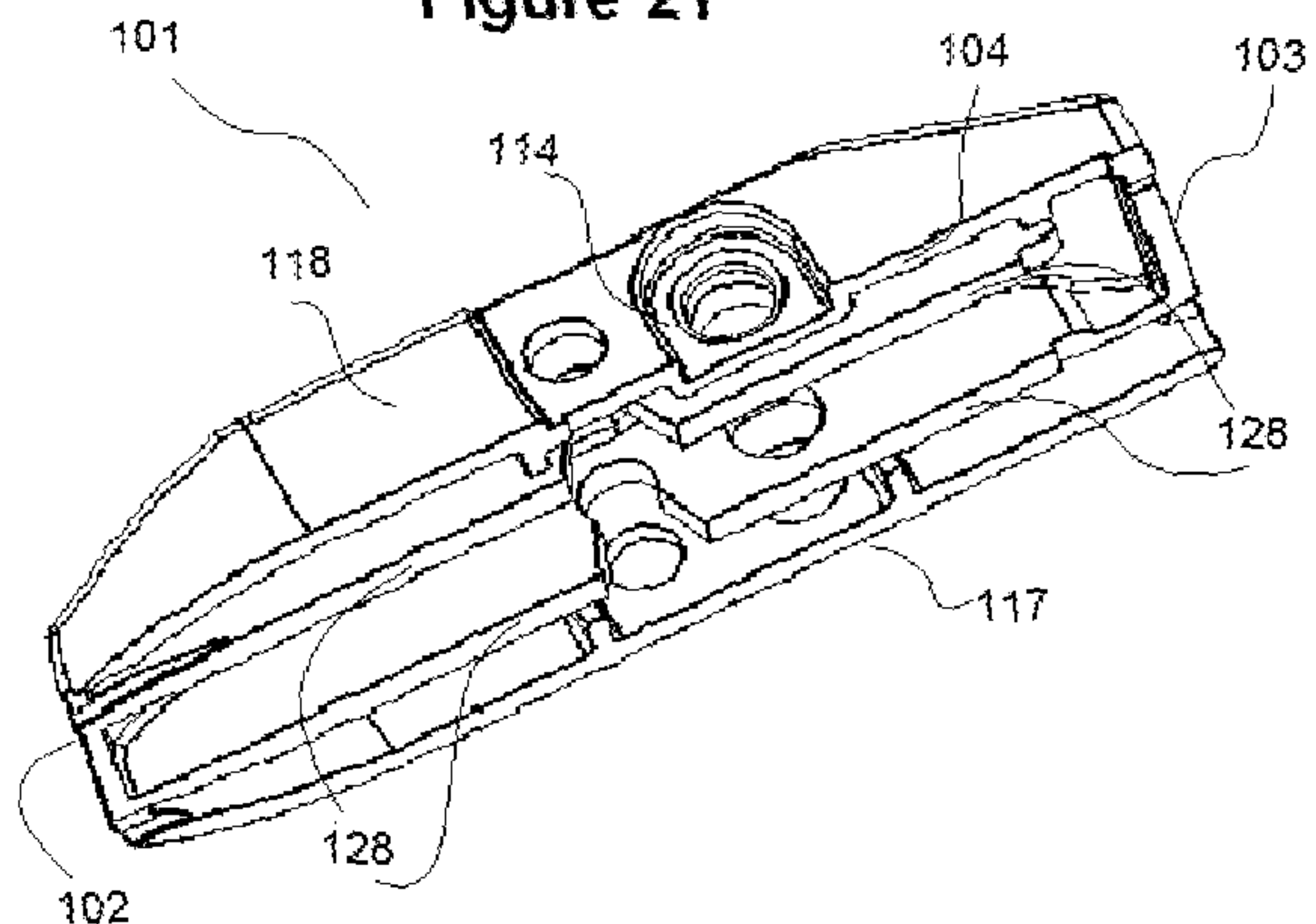

Figure 22

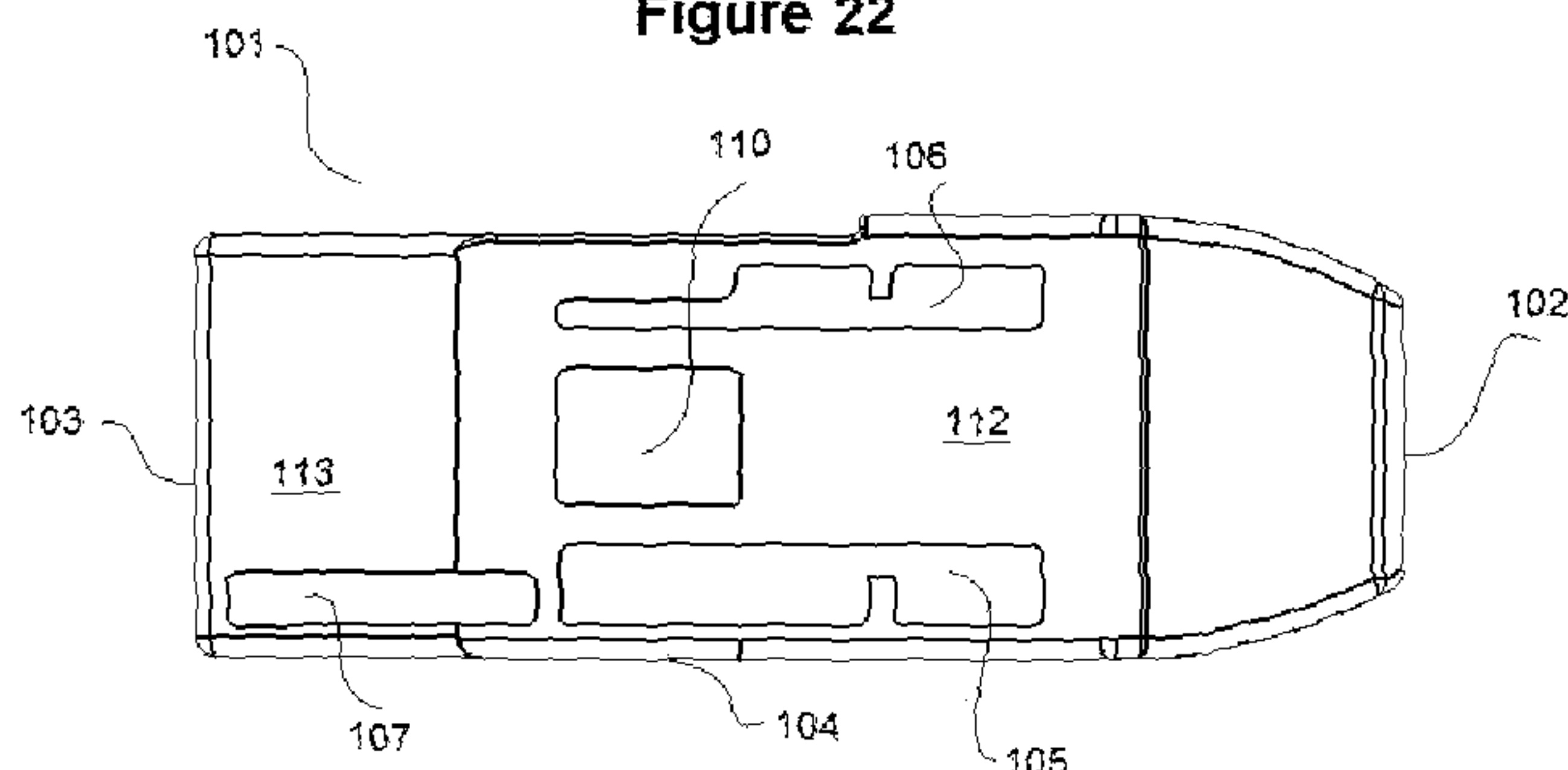

Figure 23

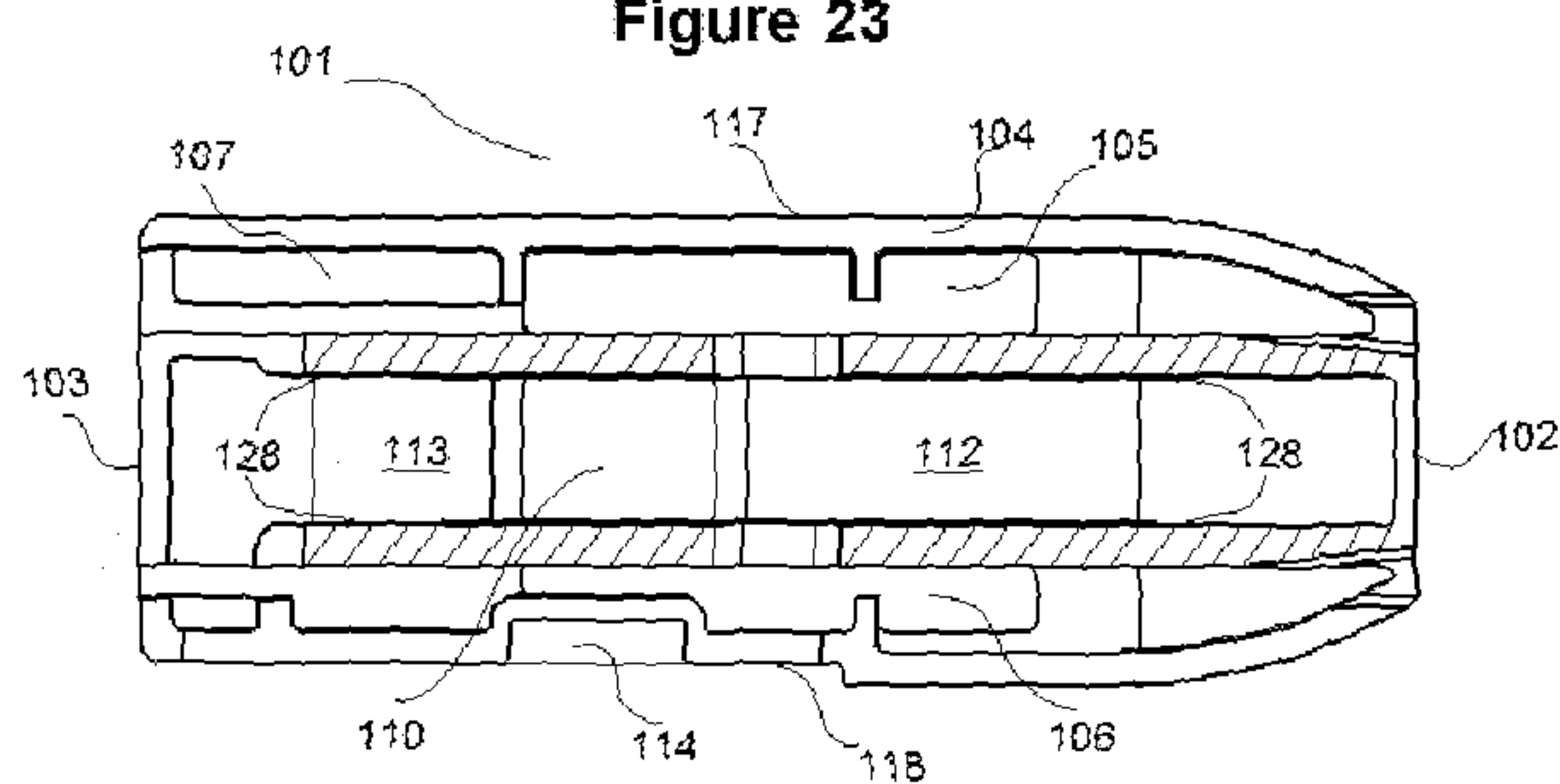

Figure 24

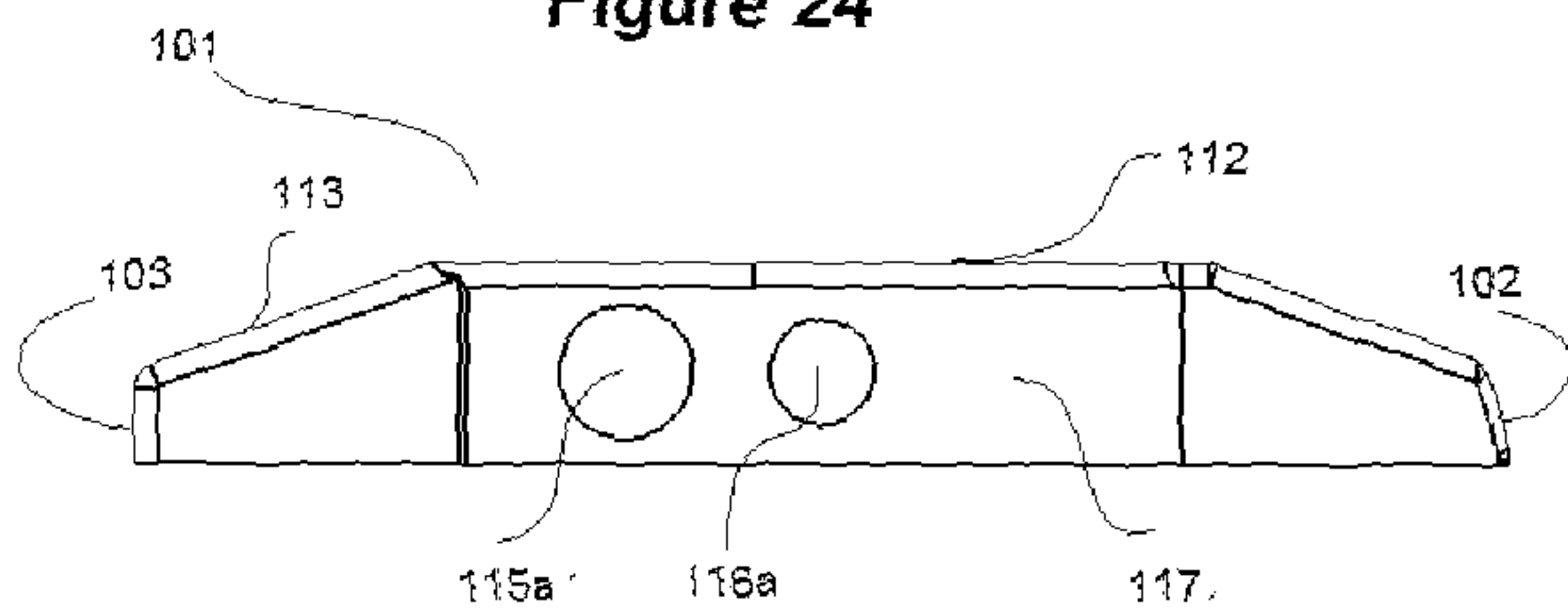

Figure 26

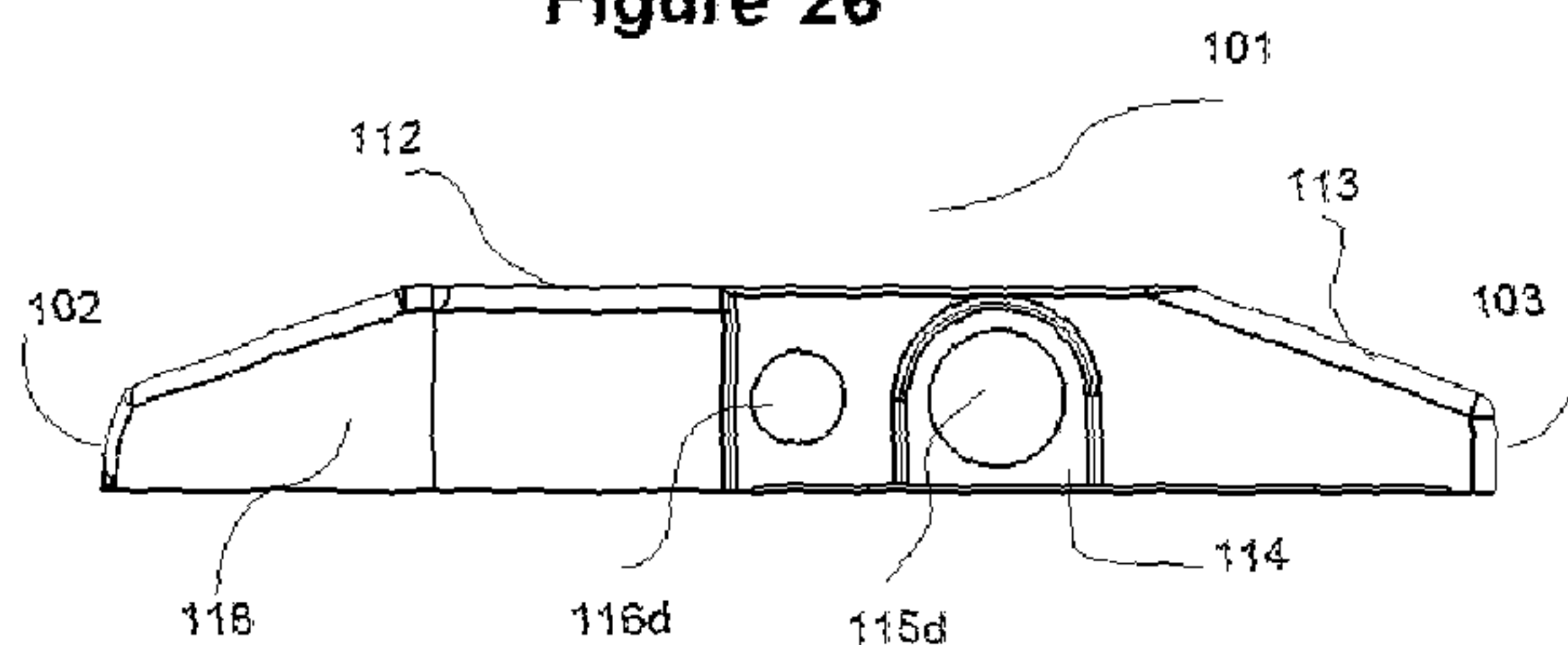

Figure 25

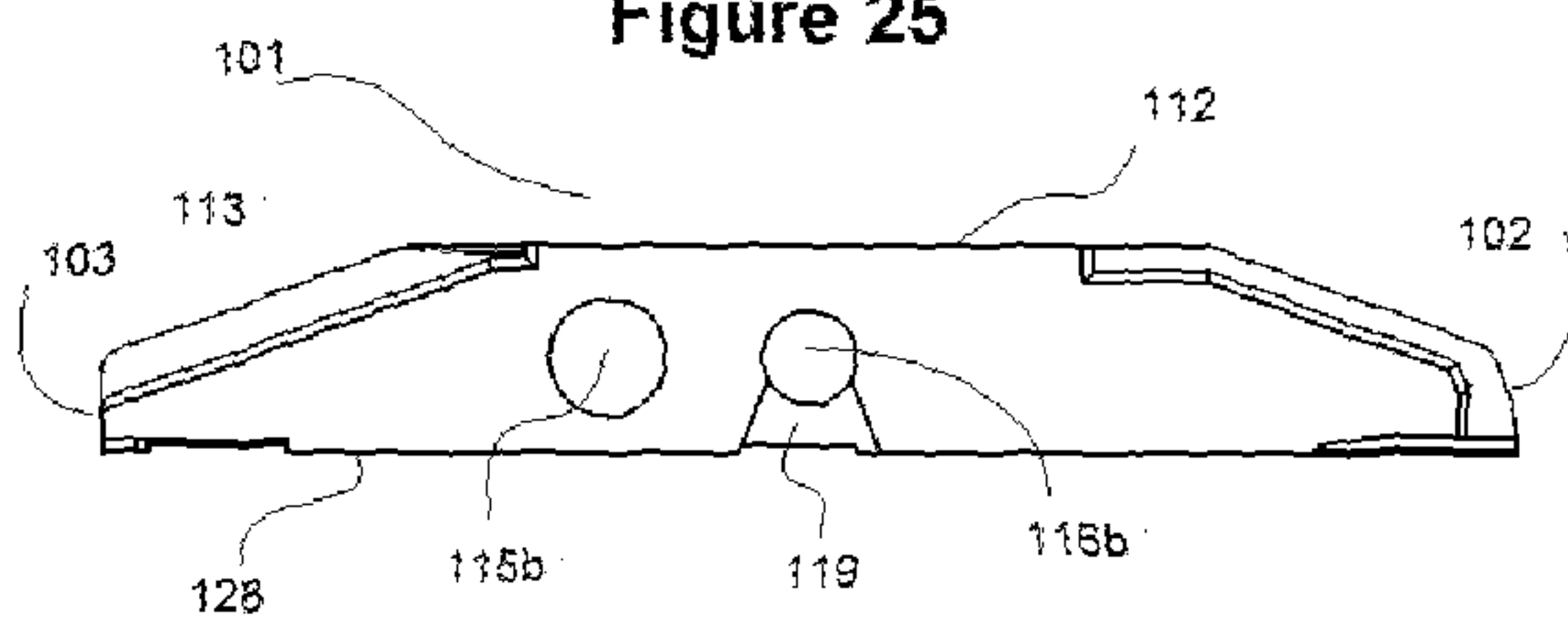

Figure 27

