

United States Patent

[11] 3,551,750

[72] Inventor **Maurice S. Sterling**
 Willow Grove, Pa.
 [21] Appl. No. **817,769**
 [22] Filed **Apr. 21, 1969**
 [45] Patented **Dec. 29, 1970**
 [73] Assignee **Hugh H. Eby, Co.**
 Philadelphia, Pa.
 a corporation of Pennsylvania

[56] **References Cited**
 UNITED STATES PATENTS
 3,173,732 3/1965 James.....339/176MP(UX)
 3,215,968 11/1965 Herrmann.....339/176MP(UX)
 3,270,311 8/1966 Deer et al.....339/176MP(UX)

Primary Examiner—Robert K. Schaefer
Assistant Examiner—D. Smith, Jr.
Attorney—Stanley Bilker

[54] **CIRCUIT BOARD CONNECTOR**
 10 Claims, 10 Drawing Figs.

[52] U.S. Cl..... **317/101,**
 339/17, 339/176
 [51] Int. Cl..... **H02b 1/02**
 [50] Field of Search..... 317/101DA,
 101CM, 101; 339/17, 17LM, 17Lc,
 176(MP)

ABSTRACT: A circuit board connector having spring contact elements received in transverse channels is provided with retaining means for exerting a clamping bias at the intermediate portions of the spring contact elements.

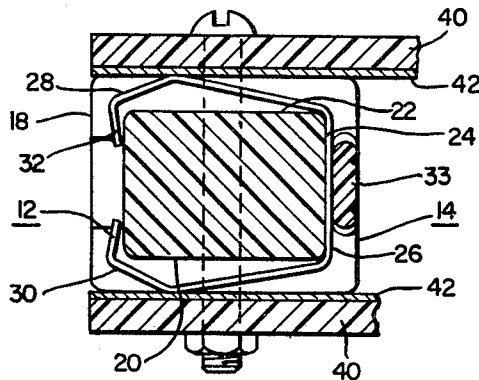

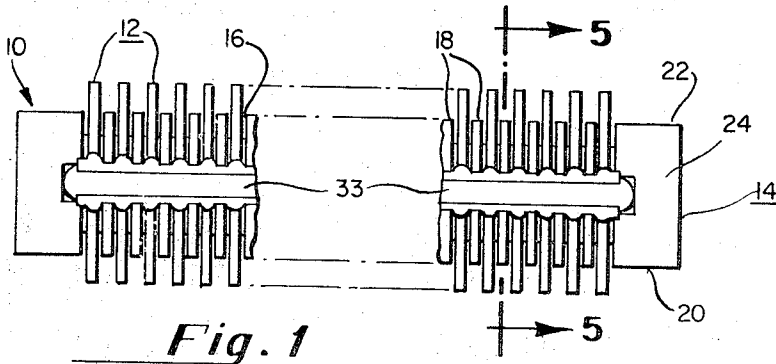

Fig. 1

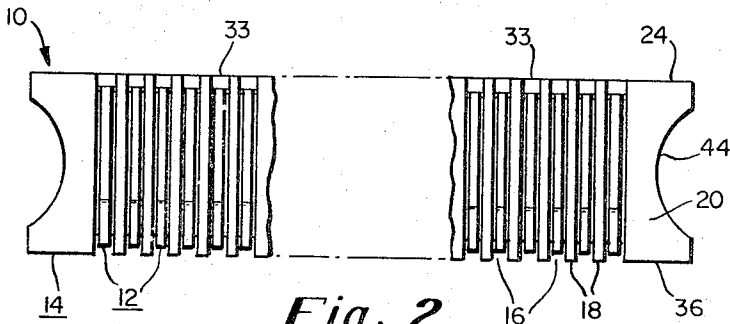

Fig. 2

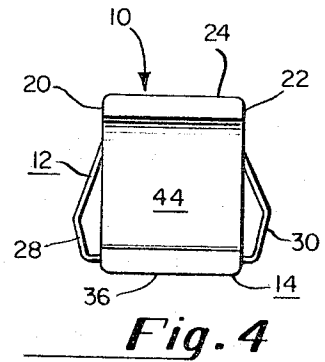

Fig. 4

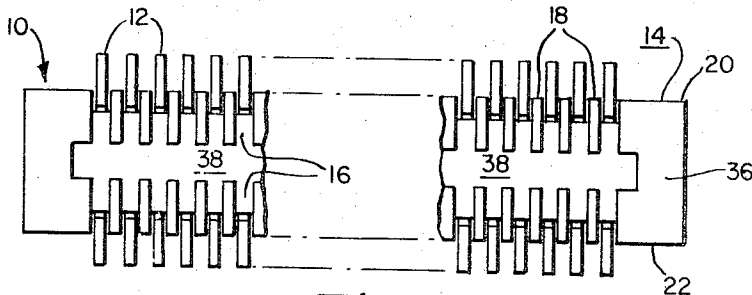

Fig. 3

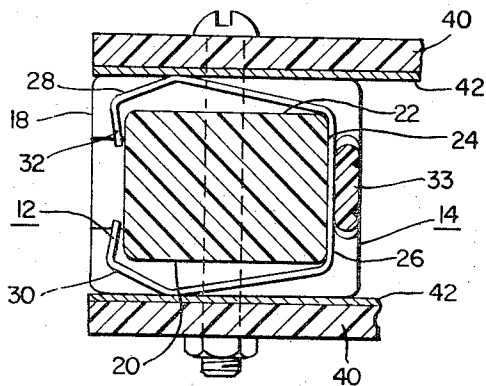

Fig. 5

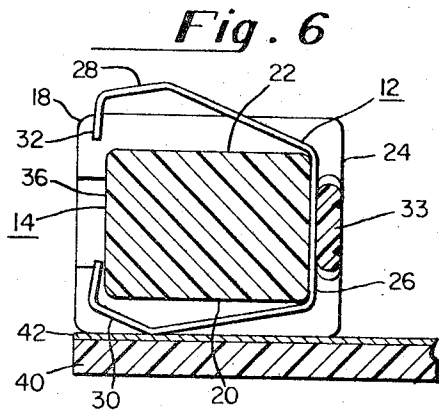

Fig. 6

INVENTOR.

Maurice S. Sterling

BY

Stanley Belker

ATTORNEY.

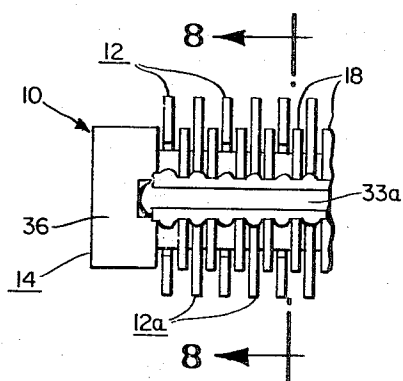

Fig. 7

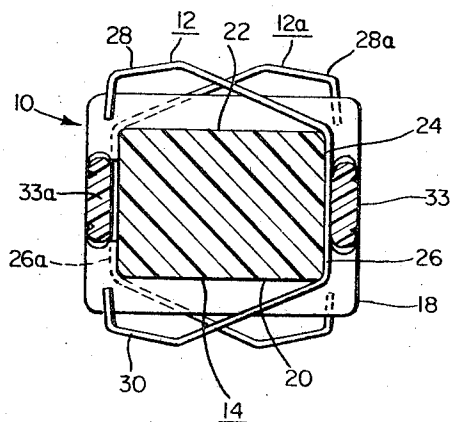

Fig. 8

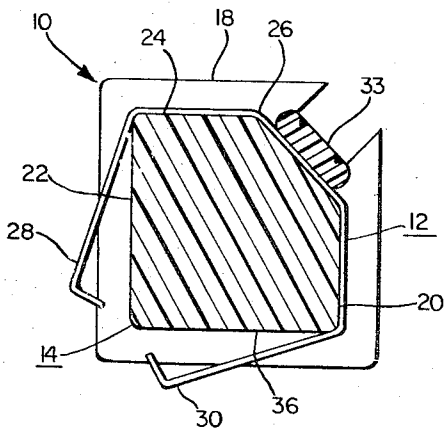

Fig. 9

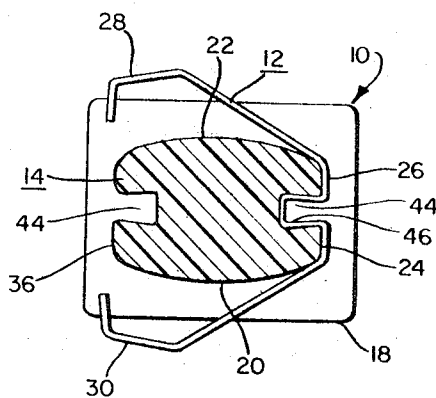

Fig. 10

INVENTOR.

Maurice S. Sterling

BY

Stanley Belter

ATTORNEY.

CIRCUIT BOARD CONNECTOR

This invention relates to connectors used for interconnecting circuit boards. Such connectors provide a detachable electrical connection between adjacent circuit boards, for example, between the upper and lower peripheral edges of spaced circuit boards stacked one above the other.

Connectors of the type described use spring contact elements to bridge the conductors of adjoining circuit boards. The spring contact elements are carried in channels on an insulator block capable of being secured in the assembly and of being readily removed therefrom.

One of the disadvantages of prior art circuit board connectors is the inability of each leg of a generally U-shaped spring contact element to resist deflection independently of the other leg connected integrally therewith. The spring contact elements of most prior art connectors are free to move transverse to the longitudinal axis of the connector when engaged by only one circuit board. In other words, a force tending to deflect only one leg of a contact into its channel will not be yieldingly resisted unless an opposing force is applied to the other leg of the same contact. It is thus not possible with such prior art connectors to establish a properly biased electrical contact with the terminals or conductors of one circuit board until the second circuit board is secured in its proper position.

It is proposed, according to the present invention, to provide an improved circuit board connector having novel means for retaining the spring contact elements. Such retaining means preferably comprises a longitudinal retaining strip on the insulator block which engages intermediate portions of the spring contact elements and exerts a clamping bias thereon. This construction permits each leg of a spring contact element to resist deflection independently of its integral counterpart, thus overcoming one of the disadvantages of the prior art constructions.

In one form of the invention, the generally U-shaped contact elements are serially assembled on the insulator block with their open ends all extending in the same direction. In modified form, alternate contact elements are inverted so as to have their open ends extending in opposite direction. The latter arrangement ensures that balanced biasing forces will be applied between the connector and the circuit board.

As another modification of the invention the legs of the U-shaped contact elements are in converging relationship, and the connector is adapted to be assembled with circuit boards that are right angles to one another.

In still another modification of the present invention the intermediate portion of each contact element is bent to an angular form which interlocks with the channel of the insulator block and secures it thereto without a separate retaining strip.

Various other objects, features, and advantages of the invention will appear more fully from the following detailed description and the accompanying drawings.

In the drawings:

FIG. 1 is a top view of a connector constructed according to the invention;

FIGS. 2, 3 and 4 are side, bottom, and end views, respectively, of the same;

FIG. 5 is a transverse sectional view of the connector, taken along line 5-5 of FIG. 1, shown on a larger scale in engagement with two circuit boards;

FIG. 6 is a view similar to FIG. 5, but with the connector engaging only one circuit board;

FIG. 7 is a fragmentary view corresponding to FIG. 3, but showing a bottom view of the connector in modified form;

FIG. 8 is an enlarged, transverse sectional view of the modified connector shown in FIG. 7, taken along line 8-8 thereof;

FIG. 9 is a view corresponding to FIGS. 5 and 6, but without circuit boards and showing another modification of the invention; and

FIG. 10 also corresponds to FIGS. 5 and 6, and it illustrates still another modification of the present invention with its contact legs disengaged.

It is to be understood that only several forms of the invention will be described in detail, and that the scope of the invention is to be determined with reference to the claims at the end hereof.

The connector 10 shown in FIGS. 1 to 6 of the drawings has a series of spring contact elements 12 mounted on a body or insulator block 14. The latter is formed, preferably by molding, of a thermoplastic material having electrical insulation properties, such as Noryl. However, a large variety of moldable insulating materials are commercially available and can be used in practicing this invention.

The configurations of the block 14 and the contacts 12, also the spacing of the contacts, are suited to the particular application and the locations of the conductors to be bridged by the connector 10. The block 14 illustrated in the drawing is an elongated member of generally rectangular cross section, and of sufficient length to accommodate a given number of serially arranged, electrically conductive contacts 12 in the desired locations.

Each spring contact element 12 is protectively received in a transverse channel 16. The channels 16 are defined by transverse ridges or barrier strips 18 that are an integral part of the block 14. Preferably, the channels 16 extend about at least three sides of the block 14, including two oppositely facing sides 20 and 22, and a third or top side 24 between them. Although the invention is not so limited, the spring contacts 12 are generally U-shaped and they extend about the sides 20, 22 and 24 of the block 14, as illustrated.

Of the various conductive and resilient materials from which the spring contacts 12 may be made, beryllium copper plated with gold over nickel flash is preferred. Each contact 12 is of unitary construction and comprises an intermediate portion 26 joined endwise to two outwardly biased or spread contact legs 28 and 30. Each contact leg has an inturred tip 32 at its free end, adapted to remain within its channel 16 under all deflection conditions. Before assembly with circuit boards, a substantial portion of the legs 28 and 30 extend outside the channels 16 and away from the sides 20 and 22 of the block 14; but after assembly they are deflected into the channels 16 entirely.

The contacts 12 are secured to the block 14 by a retainer strip 33 received in a longitudinally extending groove or recess in the top side of the block. The bottom side 36 of the block 14 is made similar to the top side 24 for convenience and symmetry, and therefore the recess 38 which can be seen in FIG. 3 may be regarded as similar to its counterpart. In order to accommodate the retainer strip 33, the recess extends across the entire series of channels 16 and to their full depth. In addition, the lateral surfaces of the retainer strip 33 are serrated to interlock with the edges of the barrier strips 18, and subsequently bonded thereto ultrasonically or by the application of heat and mechanical pressure. For this reason, it is preferred that the retainer strip also be made of thermoplastic insulating material like that of the block 14. Alternatively, adhesives may be employed.

When the connector 10 is assembled according to the invention the contacts 12 are secured with their intermediate portions 26 clamped by the retainer strip 33 against the recessed top side 24 of the block 14. With the contacts 12 thus secured, their legs 28 and 30 are each capable of independently resisting deflection without transmitting the deflection force to the other leg, since the contact operate as if rigidly built into the block 14 at their intermediate portions 26.

The connector 10 is shown in FIG. 5 assembled with a pair of circuit boards, the contact 12 having its legs 28 and 30 deflected inwardly while in biased engagement with the conductors 42 of the circuit boards. The assembly is held together by any suitable securing means, as by bolts. In order to accommodate bolts, the ends of the block 14 are provided with concave indentations 44 which cooperate with the securing means to hold the connector in position.

The assembly of FIG. 5 illustrates the legs 28 and 30 of the contact 12 deflected inwardly of the channel 16 by the assem-

bled circuit boards 40. Good electrical contact is made with the conductors 42. The deflection of the contact legs 28 and 30 is in bending about the adjacent corner of the top side 24 of the block 14, tending to deflect the intermediate contact portion 26 outwardly. However, the retaining strip 33 resists any outward deflection of the intermediate portion 26, since the strip 33 is securely connected to the top side of the block 14. The interengagement of the serrated edges of the strip 33 with the top edges of the barrier strips 18 resists longitudinal displacement of the retainer strip. Furthermore, fusion of the strip 33 to the block 14 generally along the serrated edge portions while under mechanical pressure results in continued clamping of the intermediate contact portions 26 against the top side of the block 14.

In FIG. 6 it can be seen that with the upper circuit board 40 removed from the assembly, the contact leg 28 is free to assume its normal position when undeflected, which is inherently biased away from the adjacent side 22 of block 14 and outwardly of its channel 16. The remaining circuit board 40 of FIG. 6 has its conductor 42 in good electrical contact with the other contact leg 30, since leg 30 yieldingly resists inward deflection, independently of the leg 28, due to the clamping of the adjacent intermediate contact portion 26 previously described.

From the foregoing it can be seen that connector 10 is of rugged and dependable construction; that it has improved deflection characteristics; and that it overcomes various disadvantages of prior art connectors without sacrificing economy or simplicity of manufacture.

MODIFICATIONS

Several modifications of the connector 10 shown in FIGS. 1 to 6 will now be described with reference respectively to FIGS. 7 and 8, 9, and 10. However, since the basic construction of each connector remains the same, like reference numerals will be employed to designate correspondingly similar parts of the several embodiments of the invention.

In the embodiment of the invention shown in FIGS. 7 and 8, the connector 10 has its contacts 12 arranged as if in a basket weave pattern, with every other contact in series being reversed. Thus, conventional U-shaped contacts 12 are alternated with contacts 12a of inverted U-shaped configuration. Obviously, the contacts 12a may be structurally identical with the contacts 12 except that each contact 12a is mounted with its legs 28a and 30a extending in a direction opposite to that in which the legs 28 and 30 of contact 12 extend. Furthermore, since the block 14 has its bottom side 36 made similar to its top side 24, the block 14 of the previously described embodiment is readily adapted to this modification with the alternately reversed contacts 12 and 12a by the addition of a second retainer strip 33a at the bottom side 36. The second retainer strip 33a fits the recess 38, in the same manner as its counterpart 33, in order to clamp the intermediate portions 26a of contacts 12a at the bottom of the connector. It is readily apparent that the embodiment of the invention shown in FIGS. 7 and 8 ensures that there will be a balanced biasing force exerted between the connector 10 and the circuit boards engaged thereby, unlike the unbalanced biasing contact of FIG. 5. A balanced biasing force prevents any rotation of the connector in the assembly or the application of distorting torque thereto which might reduce the effectiveness of contact between engaging surfaces.

Referring now to the embodiment of the invention shown in FIG. 9, this form of the connector 10 is adapted to interconnecting circuit boards that may be at right angles to one another. With this arrangement the cross-sectional configuration of the block 14 is altered to any suitable shape wherein the legs 28 and 30 of each contact 12 extend in converging directions. In the illustrated embodiment, the legs 28 and 30 of each contact 12 extend transversely along adjacent sides 22 and 30 of an elongated block 14 of generally square cross section; and the intermediate portion 26 is clamped by the

retainer strip 33 against a flattened corner between the other two sides 20 and 24 of the block. The strip 33 is received in a suitable recess formed in the barrier strips 18 and may be securely attached thereto by the means previously described in connection with the other embodiments.

In FIG. 10 still another modification of the invention is illustrated. In this embodiment, however, the contacts 12 have been provided with an intermediate portion 26 of novel shape to fit securely in a dovetail slot or recess 44 at the top or bottom of the block 14, without need of a retainer strip to clamp it or hold it against rotation. With a similar recess 44 at the top and bottom of the block 14 it is again possible to assemble a series of contacts 12 in alternately reversed positions, as in the embodiment of FIGS. 7 and 8.

The connector embodiment of FIG. 10 features a block 14 having curved sides, a cross section adaptable to any of the previously described embodiments. Furthermore, the recess 44 is inwardly divergent for at least a portion of its length between barrier strips 18, sufficient to accommodate, position, and secure each contact 12. The draft on the sidewalls of the recess is suited to the materials and dimensions of the fitting parts, as well as the forming processes employed, and it is therefore not restricted to any particular range. It will suffice to say in defining this embodiment in the broad sense that the sidewalls of the recess 44 are inwardly divergent, that a resilient projection 46 on the intermediate contact portion 26 is larger than the mouth of the recess 44, and that the projection 46 has surface portions interlockingly engaging the sidewalls of the recess 44 so as to resist rotation therein and removal therefrom. As illustrated, the projection 46 is generally U-shaped in form and fitted snugly to the walls of the recess 44, whereby the resilience and flexibility of the structure permits the structure to flex when snapped into the recess 44 and to spring back into firm contact with the sidewalls of the recess. The engaging flat, noncircular surfaces of the projection 46 and the recess 44 resist relative rotational movement, while the dovetail configuration of the recess secures the intermediate portion 26 and clamps the contact 12 to the body 14.

I claim:

1. A connector for interconnecting a plurality of circuit boards comprising:
 - a. an elongated insulator block having two generally opposite-facing sides and at least a third side therebetween;
 - b. a plurality of channels in said block extending transverse to the longitudinal extent thereof about said sides;
 - c. a plurality of spring contact elements in respective channels, each having an intermediate portion and two contact legs joined together, said contact legs being outwardly biased so as to have portions thereof extending outside said channels and away from said oppositely facing sides when disengaged from said circuit boards; and
 - d. retaining means exerting a clamping bias between the intermediate portions of said contact elements and said third side for securing said contact elements to said block.
2. A connector according to claim 1 wherein said spring contact elements are generally U-shaped and made of electrically conductive, resilient material.
3. A connector according to claim 1 wherein the block has a fourth side disposed opposite said third side and between the other two sides, and the spring contact elements are serially arranged along the length of said block with the intermediate portions of said elements alternately secured to the respective third and fourth sides of said block.
4. A connector according to claim 1 wherein said retaining means comprises:
 - a. a longitudinally extending recess in said third side; and
 - b. a retaining strip secured in said recess engaging the intermediate portions of said spring contact elements and exerting a bias thereon toward said third side.
5. A connector according to claim 4 wherein said channels are defined by a longitudinal series of transversely protruding barrier strips formed integrally with said block, and the retaining strip has serrated edges interengaging said barrier strips.

5

6

6. A connector according to claim 4 wherein said insulator block and said retaining strip are made of thermoplastic, electrical insulating material and joined together with the intermediate portions of said spring contact elements clamped between the third side of said block and said retaining strip.

7. A connector according to claim 6 wherein said block and said retaining strip are fused together.

8. A connector according to claim 1 assembled with a pair of circuit boards, each having conductors on a side thereof in mutually facing relationship with one of the two oppositely facing sides of said block, the conductors having terminal portions in contact with said spring contact elements.

9. A connector according to claim 1 wherein the contact

legs of each spring contact element extend substantially convergently along generally oppositely facing sides that are at right angles to one another.

10. A connector according to claim 1 wherein said retaining means comprises a projection formed in the intermediate portion of each contact element, and an inwardly divergent slot formed in the third side of said block for receiving said projection for each contact element in interlocking relationship therewith, said projection and said slot presenting noncircular surface portions for engagement with one another, whereby said retaining means secures said contact element to said block and resists relative rotational movement therebetween.

15

20

25

30

35

40

45

50

55

60

65

70

75