



(86) **Date de dépôt PCT/PCT Filing Date:** 2012/12/28
 (87) **Date publication PCT/PCT Publication Date:** 2014/07/03
 (85) **Entrée phase nationale/National Entry:** 2015/06/25
 (86) **N° demande PCT/PCT Application No.:** US 2012/072174
 (87) **N° publication PCT/PCT Publication No.:** 2014/105065

(51) **Cl.Int./Int.Cl. C10B 29/00** (2006.01),
C10B 25/00 (2006.01)
 (71) **Demandeur/Applicant:**
SUNCOKE TECHNOLOGY AND DEVELOPMENT LLC.,
US
 (72) **Inventeurs/Inventors:**
WEST, GARY DEAN, US;
CHOI, CHUN WAI, US;
HIRT, THOMAS JAMES, US
 (74) **Agent:** GOWLING LAFLEUR HENDERSON LLP

(54) **Titre : COUVERCLES DE COLONNE DE VENTILATION ET SYSTEMES ET PROCEDES ASSOCIES**
 (54) **Title: VENT STACK LIDS AND ASSOCIATED SYSTEMS AND METHODS**

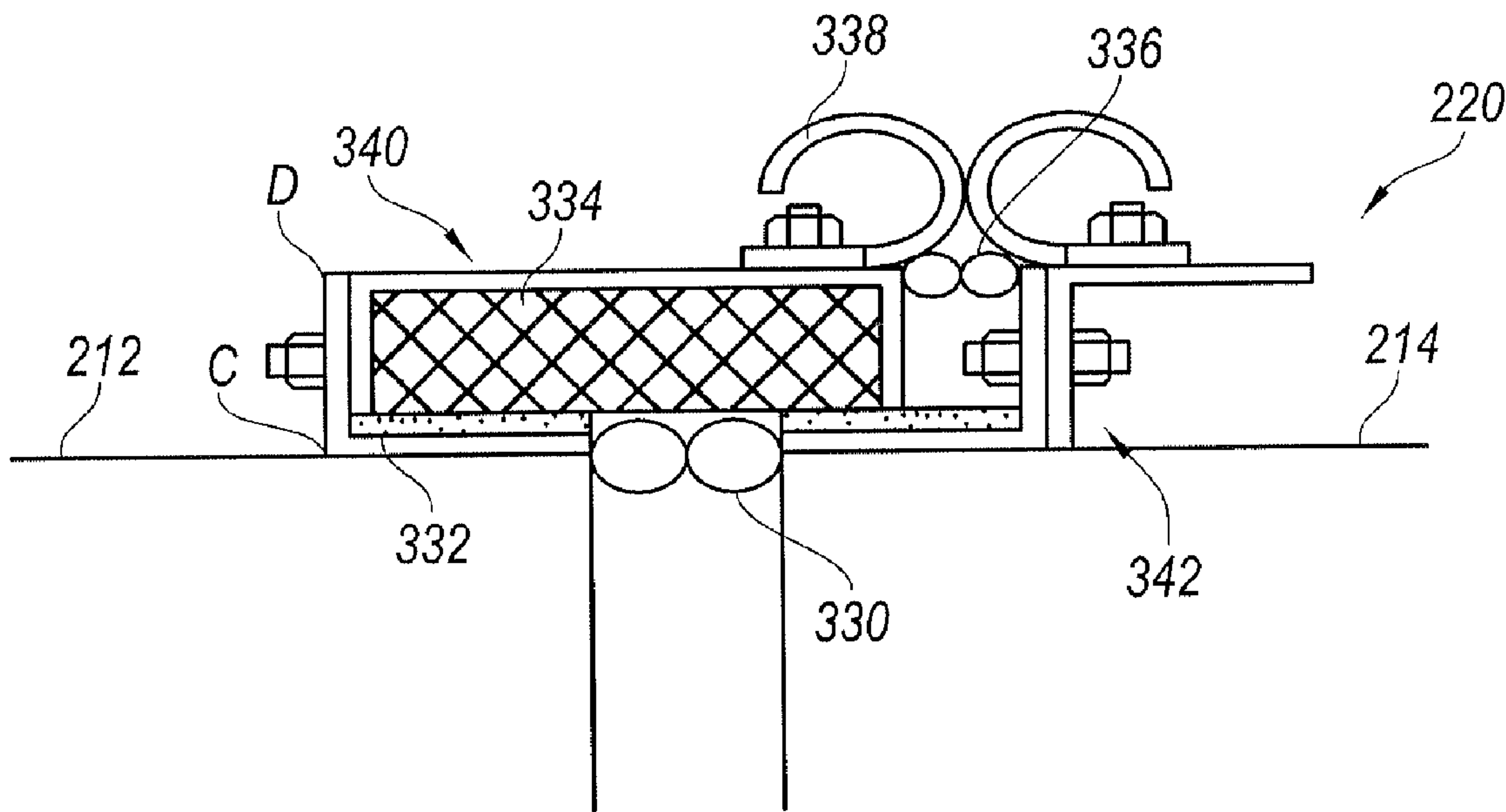

Fig. 3

(57) **Abrégé/Abstract:**

The present technology is generally directed to vent stack lids and associated systems and methods. In particular, several embodiments are directed to vent stack lids having improved sealing properties in a coke processing system. In a particular embodiment, a vent stack lid comprises a first lid portion proximate to and at least partially spaced apart from a second lid portion. The vent stack lid further comprises a first sealing portion coupled to the first lid portion and a second sealing portion coupled to the second lid portion. In several embodiments, the second sealing portion at least partially overlaps the first sealing portion over the space between the first and second lid portions. In further embodiments, at least one of the first or second sealing portions includes layers of tadpole seals, spring seals, rigid refractory material, and/or flexible refractory blanket.

(12) INTERNATIONAL APPLICATION PUBLISHED UNDER THE PATENT COOPERATION TREATY (PCT)

(19) World Intellectual Property
Organization
International Bureau(43) International Publication Date
3 July 2014 (03.07.2014)(10) International Publication Number
WO 2014/105065 A1

- (51) **International Patent Classification:**
C10B 29/00 (2006.01) *C10B 25/00* (2006.01)
- (21) **International Application Number:**
PCT/US2012/072174
- (22) **International Filing Date:**
28 December 2012 (28.12.2012)
- (25) **Filing Language:** English
- (26) **Publication Language:** English
- (71) **Applicant:** SUNCOKE TECHNOLOGY AND DEVELOPMENT LLC. [US/US]; 1011 Warrenville Road 6th Floor, Lisle, IL 60532 (US).
- (72) **Inventors:** WEST, Gary, Dean; 1011 Warrenville Road 6th Floor, Lisle, IL 60532 (US). CHOI, Chun, Wai; 1011 Warrenville Road 6th Floor, Lisle, IL 60532 (US). HIRT, Thomas, James; 1011 Warrenville Road 6th Floor, Lisle, IL 60532 (US).
- (74) **Agents:** BETCHER, Susan, D. et al.; Perkins Coie LLP, P.O. Box 1247, Seattle, WA 98111-1247 (US).
- (81) **Designated States** (unless otherwise indicated, for every kind of national protection available): AE, AG, AL, AM,

AO, AT, AU, AZ, BA, BB, BG, BH, BN, BR, BW, BY, BZ, CA, CH, CL, CN, CO, CR, CU, CZ, DE, DK, DM, DO, DZ, EC, EE, EG, ES, FI, GB, GD, GE, GH, GM, GT, HN, HR, HU, ID, IL, IN, IS, JP, KE, KG, KM, KN, KP, KR, KZ, LA, LC, LK, LR, LS, LT, LU, LY, MA, MD, ME, MG, MK, MN, MW, MX, MY, MZ, NA, NG, NI, NO, NZ, OM, PA, PE, PG, PH, PL, PT, QA, RO, RS, RU, RW, SC, SD, SE, SG, SK, SL, SM, ST, SV, SY, TH, TJ, TM, TN, TR, TT, TZ, UA, UG, US, UZ, VC, VN, ZA, ZM, ZW.

- (84) **Designated States** (unless otherwise indicated, for every kind of regional protection available): ARIPO (BW, GH, GM, KE, LR, LS, MW, MZ, NA, RW, SD, SL, SZ, TZ, UG, ZM, ZW), Eurasian (AM, AZ, BY, KG, KZ, RU, TJ, TM), European (AL, AT, BE, BG, CH, CY, CZ, DE, DK, EE, ES, FI, FR, GB, GR, HR, HU, IE, IS, IT, LT, LU, LV, MC, MK, MT, NL, NO, PL, PT, RO, RS, SE, SI, SK, SM, TR), OAPI (BF, BJ, CF, CG, CI, CM, GA, GN, GQ, GW, ML, MR, NE, SN, TD, TG).

Published:

— with international search report (Art. 21(3))

(54) **Title:** VENT STACK LIDS AND ASSOCIATED SYSTEMS AND METHODS

Fig. 3

(57) **Abstract:** The present technology is generally directed to vent stack lids and associated systems and methods. In particular, several embodiments are directed to vent stack lids having improved sealing properties in a coke processing system. In a particular embodiment, a vent stack lid comprises a first lid portion proximate to and at least partially spaced apart from a second lid portion. The vent stack lid further comprises a first sealing portion coupled to the first lid portion and a second sealing portion coupled to the second lid portion. In several embodiments, the second sealing portion at least partially overlaps the first sealing portion over the space between the first and second lid portions. In further embodiments, at least one of the first or second sealing portions includes layers of tadpole seals, spring seals, rigid refractory material, and/or flexible refractory blanket.

WO 2014/105065 A1

VENT STACK LIDS AND ASSOCIATED SYSTEMS AND METHODS

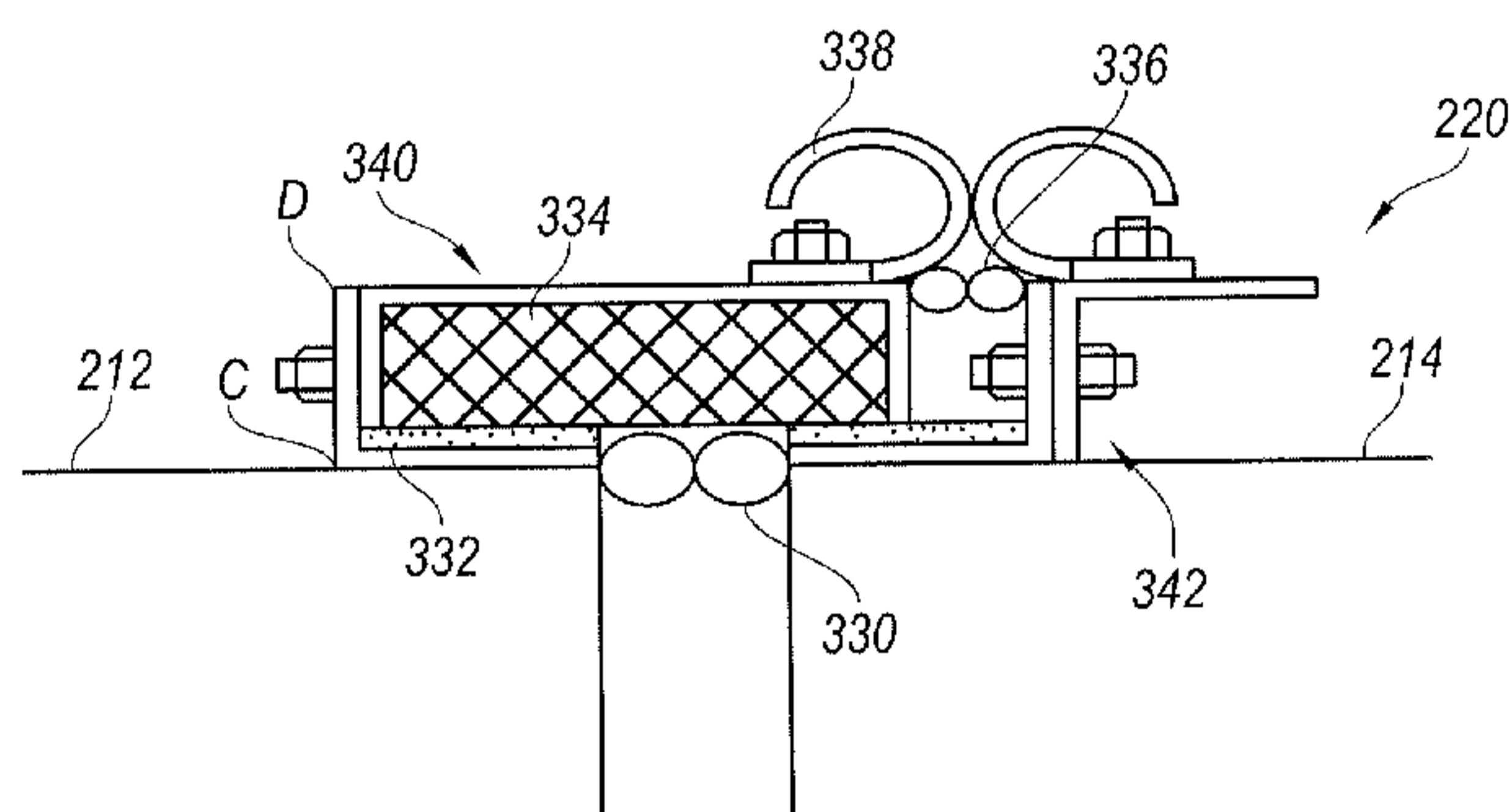
TECHNICAL FIELD

[0001] The present technology is generally directed to vent stack lids and associated systems and methods. In particular, several embodiments are directed to vent stack lids having improved sealing properties in a coke processing system.

BACKGROUND

[0002] Coke is a solid carbon fuel and carbon source used to melt and reduce iron ore in the production of steel. In one process, known as the "Thompson Coking Process," coke is produced by batch feeding pulverized coal to an oven that is sealed and heated to very high temperatures for 24 to 48 hours under closely-controlled atmospheric conditions. Coking ovens have been used for many years to convert coal into metallurgical coke. During the coking process, finely crushed coal is heated under controlled temperature conditions to devolatilize the coal and form a fused mass of coke having a predetermined porosity and strength.

[0003] The coke ovens create extremely hot exhaust gases, the gases sometimes reaching temperatures of 2,000 degrees Fahrenheit or hotter. Coke plants typically include vent stacks to expel these hot exhaust gases, either on a routine or emergency venting basis, or for maintenance purposes. The vent stacks can include stack lids intended to contain the exhaust in the stack when venting is undesirable, and also to keep atmospheric air from entering the negative-pressure coke processing environment. The vent stack lids typically include two side-by-side lid portions, each capable of opening in a clamshell configuration. However, over time, the side-by-side portions have a tendency to move slightly apart due to mechanical fatigue of the lid, the hinge/joint between the lid and the stack, or the stack itself. This creates a gap between the lid portions. The open gap can cause air in-leakage from the atmosphere into the stack to affect the process performance, and can leak exhaust gas into the outside environment at unintended times. Even if there is a seal on the lid, a small amount of fatigue movement of the lid portions releases enough hot gas that the seal can be

quickly burned off. Accordingly, there exists a need to improve vent stack design to withstand high temperatures and stack lid shifting.

BRIEF DESCRIPTION OF THE DRAWINGS

[0004] Figure 1 is a schematic illustration of a horizontal heat recovery coke plant, configured in accordance with embodiments of the technology.

[0005] Figure 2 is a partially schematic illustration of a vent stack system configured in accordance with embodiments of the technology.

[0006] Figure 3 is a partially schematic illustration of a vent stack lid sealing system configured in accordance with embodiments of the technology.

[0007] Figure 4 is a partially schematic illustration of a vent stack lid sealing system configured in accordance with further embodiments of the technology.

[0008] Figure 5A is a side view of a vent stack lid configured in accordance with embodiments of the technology.

[0009] Figure 5B is an isometric view of the vent stack lid of Figure 5A configured in accordance with embodiments of the technology.

DETAILED DESCRIPTION

[0010] The present technology is generally directed to vent stack lids and associated systems and methods. In particular, several embodiments are directed to vent stack lids having improved sealing properties in a coke processing system. In a particular embodiment, a vent stack lid comprises a first lid portion proximate to and at least partially spaced apart from a second lid portion. The vent stack lid further comprises a first sealing portion coupled to the first lid portion and a second sealing portion coupled to the second lid portion. In several embodiments, the second sealing portion at least partially overlaps the first sealing portion over the space between the first and second lid portions. In further embodiments, at least one of the first or second sealing portions includes layers of tadpole seals, spring seals, rigid refractory material, and/or flexible refractory blanket.

[0011] Specific details of several embodiments of the technology are described below with reference to Figures 1-5B. Other details describing well-known structures and systems often associated with coal processing and coke ovens have not been set forth in the following disclosure to avoid unnecessarily obscuring the description of the various embodiments of the technology. Many of the details, dimensions, angles, and other features shown in the Figures are merely illustrative of particular embodiments of the technology. Accordingly, other embodiments can have other details, dimensions, angles, and features without departing from the spirit or scope of the present technology. A person of ordinary skill in the art, therefore, will accordingly understand that the technology may have other embodiments with additional elements, or the technology may have other embodiments without several of the features shown and described below with reference to Figures 1-5B.

[0012] Figure 1 is a schematic illustration of a horizontal heat recovery (HHR) coke plant 100, configured in accordance with embodiments of the technology. The HHR coke plant 100 comprises ovens 105, along with heat recovery steam generators (HRSGs) 120 and an air quality control system 130 (e.g., an exhaust or flue gas desulfurization (FGD) system), both of which are positioned fluidly downstream from the ovens 105 and both of which are fluidly connected to the ovens 105 by suitable ducts. The HHR coke plant 100 also includes a common tunnel 110 fluidly connecting individual ovens 105 to the HRSGs 120. One or more crossover ducts 115 fluidly connect the common tunnel 110 to the HRSGs 120. A cooled gas duct 125 transports the cooled gas from the HRSGs to the flue gas desulfurization (FGD) system 130. Fluidly connected and further downstream are a baghouse 135 for collecting particulates, at least one draft fan 140 for controlling air pressure within the system, and a main gas stack 145 for exhausting cooled, treated exhaust to the environment. Steam lines 150 can interconnect the HRSG 120 and a cogeneration plant 155 so that the recovered heat can be utilized. Various coke plants 100 can have different proportions of ovens 105, HRSGs 120, and other structures.

[0013] The plant 100 can further include a vent stack 160 fluidly connected to the common tunnel 110 and configured as an optional route to vent combusted flue gas to the atmosphere. For example, the exhaust gases can be routed to the vent stack 160 as a bypass option when the HRSGs 120 or downstream equipment is malfunctioning or undergoing maintenance. In further

embodiments, the vent stack 160 can be positioned further downstream in the plant 100 or there can be multiple vent stacks 160. As will be discussed in further detail below with reference to Figures 2-5B, the vent stack 160 can include a vent stack lid configured to contain the exhaust gas in the vent stack 160 and prevent air in-leakage when venting is undesirable.

[0014] Figure 2 is a partially schematic illustration of a vent stack system 200 configured in accordance with embodiments of the technology. The vent stack system 200 can comprise a vent stack 202 and a vent stack lid 210. The vent stack lid 210 can include multiple lid portions, such as a first lid portion 212 that meets with a second lid portion 214 over the vent stack 202. In some embodiments, the first lid portion 212 and second lid portion 214 have a clamshell configuration and can open in the direction of the arrowed lines by pivoting at points A and B with the use of an actuator and/or a counterweight (not shown). In further embodiments, the first and second lid portions 212, 214 can open via a sliding motion or other suitable movement. The first and second lid portions 212, 214 can meet or nearly meet at a junction region having a vent stack sealing system 220. In some cases, there is a gap of approximately two inches between the first and second lid portions 212, 214. The gap can be larger or smaller in other situations, or can increase over the lifetime of the equipment due to mechanical fatigue. As will be described in further detail below with reference to Figures 3-5B, the sealing system 220 at the junction region can include overlapping seals and/or a plurality of layers of seals to contain hot exhaust gas in the vent stack 202.

[0015] Figure 3 is a partially schematic illustration of the vent stack lid sealing system 220 configured in accordance with embodiments of the technology. As discussed above, the sealing system 220 closes the gap between the first lid portion 212 and the second lid portion 214 and can extend across the top and/or down the sides of the lid portions 212, 214. In the illustrated embodiment, the sealing system 220 includes a first sealing portion 340 coupled to the first lid portion 212 and a second sealing portion 342 coupled to the second lid portion 214. In several embodiments, the first lid portion 212 and/or second sealing portion 342 comprises layers of different materials having different material properties. For example, the materials can be rigid, flexible, hard, soft, permeable, and/or impermeable, or any combination of these qualities. In a particular embodiment, a layer of rigid steel or refractory can be combined with a layer of more

flexible refractory. In some embodiments, the first and/or second sealing portions 340, 342 comprise a generally rigid framework, comprising ceramic, stainless steel, refractory, and/or other material suitable for the environmental conditions at the vent stack lid. As will be described in further detail below, at least a section of the sealing portions 340, 342 is generally soft or flexible. While in the illustrated embodiment the first sealing portion 340 is generally rectangular shaped and the second sealing portion 342 is generally Z-shaped, the first and/or second sealing portions 340 can have other complementary shapes (e.g., blocks, channels, etc.) in other embodiments of the technology.

[0016] Each of the first and second sealing portions 340, 342 can include a tadpole seal 330 positioned in the gap between the first lid portion 212 and second lid portion 214. The tadpole seals 330 can be adjacent to one another and substantially fill the gap. The tadpole seals 330 can be a high-temperature resistant material, such as ceramic rope. In further embodiments, only one of the first or second sealing portions 340, 342 includes a tadpole seal 330, or the tadpole seals 330 can be absent altogether. The seals 330 can be larger or smaller as necessary to substantially fill the gap, and need not be the same size. In further embodiments, the seals 330 can be stacked vertically rather than positioned side-by-side.

[0017] The sealing system 220 can further include a blanket layer 332 on each of the first sealing portion 340 and the second sealing portion 342. The blanket layer 332 can be a high-temperature-resistant material and can be generally soft or flexible, such as a thermal ceramic refractory blanket like Kaowool. In some embodiments, the blanket 332 or another soft or flexible material sits directly atop the vent stack 202 (shown in Figure 2). In further embodiments, the blanket 332 can be positioned under the first and second lid portions 212, 214, and on or in the vent stack 202. The soft/hard interface between the soft blanket 332 and the vent stack lip can further reduce leaks because the soft material is able to conform to the rigid shape of the vent stack lip.

[0018] The first sealing portion 340 can further include a refractory material 334 above the blanket 332 and tadpole seal 330. The refractory material 334 overlaps the blanket layer 332 on the second sealing portion 342. This overlapping feature can provide further insurance against vent stack leaks. The degree of overlap can be varied in different embodiments of the disclosure. For example, the sealing system 220 can range from no overlap to overlap that spans nearly the entire

width of the vent stack lid. As will be discussed in further detail with reference to Figures 5A and 5B, in some cases the side sections of the lid portions 212, 214 (or the sealing system 220 on the side portions) can overlap. In still further embodiments, there can be multiple layers of overlaps in the sealing system 220. As described above, the generally hard refractory material 334 adjacent to the generally soft blanket 332 can provide a more conforming seal and can further inhibit misalignment of the first and second lid portions 212, 214.

[0019] The first and second sealing portions 340, 342 can further include another layer of tadpole seals 336. The tadpole seals 336 can be adjacent to or above the refractory material 334 and can be the same or different size from the tadpole seals 330. The tadpole seals 336 can be ceramic rope or other similar material. In some embodiments, in addition to or in place of the tadpole seals 336, the sealing system 220 can include an additional overlap region of the first sealing portion 340 and second sealing portion 342, similar to the overlap described above. Above the tadpole seals 336, the first and second sealing portions 340, 342 can each include a spring seal 338. The spring seals 338 can be curved metal (e.g., stainless steel or other suitable material) and can press against one another to provide additional gap closure. In further embodiments, the spring seals 338 need not be curved, but can instead be plates or other shapes. While the tadpole seals 330, 336 and spring seals 338 are illustrated as pairs of side-by-side contact seals, in further embodiments these seals need not come in pairs. For example, in further embodiments, a single tadpole seal can fill the gap between the lid portions 212, 214 or a single metal spring seal or plate can be used alone. The various layers of sealing features can insulate the spring seals 338 from burning from exhaust heat.

[0020] In further embodiments, the sealing system 220 can have only a portion of the illustrated sealing features and/or there can be multiple layers of individual sealing features (e.g., more layers refractory 334 or blanket 332). Further, the various layers of sealing features can be present in a different order than illustrated. Additionally, while some sealing features (e.g., the refractory 334) are illustrated on only the first sealing portion 340, these features can additionally or alternately be located on the second sealing portion 342. Further, the first sealing portion 340 and second sealing portion 342 can overlap to a greater or lesser degree or can not overlap at all. For example, in a particular embodiment, the tadpole seals 330 and spring seals 338 can be positioned directly over the gap between the first and second lid portions 212, 214. Such a design can be used

with or without other sealing elements (e.g., the refractory 334, blanket 332, and the associated overlap region) of the illustrated sealing system 220. In still further embodiments, additional types of seals, valves, lids, or other mechanisms known in the art can be used as part of the sealing system 220.

[0021] The first and second sealing portions 340, 342 can move with the first lid portion 212 and second lid portion 214, respectively, and/or can be capable of further hinged or sliding movement. In several embodiments, the first lid portion 212 and/or second lid portion 214 can open and/or close independently, and without requiring that the opposite lid portion be open. In other words, the first lid portion 212 and first sealing portion 340 can open without requiring that the second lid portion 214 and second sealing portion 342 be open, and vice versa. In some embodiments, the first sealing portion 340 can be movable relative to the first lid portion 212. For example, the first sealing portion 340 can hinge or pivot (e.g., at points C or D). The second sealing portion 342 can pivot at similar locations. In some cases, one or both sealing portions 340, 342 can pivot with the use of an actuator and/or a controller. In further embodiments, the first and/or second sealing portions 340, 342 can be slidably coupled to the first and second lid portions 212, 214, respectively, such that the sealing portions 340, 342 can slide away from one another when the lid portions 212, 214 are opening/closing. The first and second sealing portions 340, 342 can accordingly open and close independently without causing damage to the sealing portions 340, 342. In some embodiments, the sealing portions 340, 342 and/or the lid portions 212, 214 can lock in place. In still further embodiments, the entire sealing system 220 is coupled to only one of the first or second lid portions 212, 214, and can optionally make use of the pivot or sliding movement described above during opening and closing.

[0022] Figure 4 is a partially schematic illustration of a vent stack lid sealing system 420 configured in accordance with further embodiments of the technology. The sealing system 420 can include several features generally similar to the sealing system 220 described above. For example, the sealing system 420 can include multiple layers of different materials having different material properties. For example, the materials can be rigid, flexible, hard, soft, permeable, and/or impermeable, or any combination of these qualities. These layers can stack and/or overlap to provide improved sealing and prevent gases from traversing the sealing system 420.

[0023] In the illustrated embodiment, the sealing system 420 includes a first sealing portion 440 coupled to the first lid portion 212 and a second sealing portion 442 coupled to the second lid portion 214. Each the first sealing portion 440 and the second sealing portion 442 includes a blanket layer 432 positioned on the first lid portion 212 and second lid portion 214, respectively. The blanket layer 432 can comprise a generally soft or flexible refractory or other insulating fiber material. In some embodiments, the blanket layer 432 can extend or wrap around the first and second lid portions 212, 214. The blanket layers 432 on the respective first and second sealing portions 440, 442 can meet as they wrap around the first and second lid portions 212, 214 and contact each other in the gap between the first and second lid portions 212, 214. The blanket layers 432 can thereby inhibit gas flow in and out of the vent stack. The blanket layer 432 can comprise any high-temperature-resistant material, such as ceramic refractory blanket, and can prevent the first and second lid portions 212, 214 from burning. In further embodiments, the blanket layer 432 need not wrap around the first and second lid portions 212, 214, or there can be a single piece (e.g., a sheet) of blanket layer 432 covering the space between the first and second lid portions 212, 214. In some embodiments, the sealing system 420 further includes an insulation layer 472 in or on the vent stack and positioned at least partially under the blanket layer 432 and the first and second lid portions 212, 214. The insulation layer 472 can comprise a single piece or multiple pieces (e.g., multiple pieces each individually attached to the first or second lid portion 212, 214). The insulation layer 472 can comprise a fiber module or other suitable material that can insulate the blanket layer 472 and lid portions 212, 214 from excessive heat from exhaust gas.

[0024] The sealing system 420 can further include generally rigid, castable refractory material 434 positioned above the blanket layer 432 and the first and second lid portions 212, 214. In the illustrated embodiment, the refractory material 434 can be coupled to the first sealing portion 440, but can additionally or alternately be coupled to the second sealing portion 442. In some embodiments, the refractory material 434 is cast around one or more reinforcing structures 474 or tensioning devices. While the reinforcing structures 474 are shown as Y-shaped, in further embodiments the structures 474 can be other shapes or can be absent altogether.

[0025] The refractory material 434 overlaps the blanket layer 432 on the second sealing portion 442. This overlapping feature can provide further insurance against vent stack leaks. The

degree of overlap can be varied in different embodiments of the technology. For example, the sealing system 420 can range from no overlap to overlap that spans nearly the entire width of the vent stack lid, and in some cases the side sections of the lid portions 212, 214 can overlap. As described above, the generally hard refractory material 434 adjacent to the generally soft blanket 432 can provide a more conforming seal and can further inhibit misalignment of the first and second lid portions 212, 214.

[0026] A tadpole seal 436 can further inhibit air transfer in and out of the vent stack. The illustrated tadpole seal 436 is attached to the first sealing portion 440 via a fastener 476. The tadpole seal fills a space between the first sealing portion 440 and second sealing portion 442 (e.g., between the refractory 434 on the first sealing portion 440 and a vertical extension portion 478 of the second sealing portion 442). In further embodiments, there can be more or fewer tadpole seals 436, attached by other types of fasteners or friction fit.

[0027] One or both of the first or second sealing portions 440, 442 can be movable relative to one another or the vent stack lid portions 212, 214. For example, in the illustrated embodiment, the first sealing portion 440 is pivotably movable around hinge point E in the direction of rotation R. The hinge can be coupled to the first lid portion 212, refractory 434, or other portion of the first sealing portion 440, and can allow the first sealing portion 440 to pivot toward a pivot support 470. In further embodiments, the second sealing portion 442 can likewise move relative to the first and second lid portions 212, 214 or to the first sealing portion 440. For example, the first and/or second sealing portions 440, 442 can be independently movable such that one or either side can open and/or close without the other side having to move. In other embodiments, one lid portion 212 or 214 must be closed in order for the other to close. In further embodiments, the first and second lid portions 212, 214 or the first and second sealing portions 440, 442 can be configured for sliding movement, such as horizontal sliding movement or a combination of hinged and sliding movement. In other embodiments, the first and second lid portions 212 are configured for sliding movement while the first and/or second lid portions 212, 214 are angled relative to a horizontal plane.

[0028] In further embodiments, the sealing system 420 can have only a portion of the illustrated sealing features and/or there can be multiple layers of individual sealing features (e.g., more layers refractory 434 or blanket 432). Further, the various layers of sealing features can be

present in a different order than illustrated. Additionally, while some sealing features (e.g., the refractory 434) are illustrated on only the first sealing portion 440, these features can additionally or alternately be located on the second sealing portion 442. Further, the first sealing portion 440 and second sealing portion 442 can overlap to a greater or lesser degree or can not overlap at all. In still further embodiments, additional types of seals, valves, lids, or other mechanisms known in the art can be used as part of the sealing system 420.

[0029] Figure 5A is a side view of a vent stack lid 510 configured in accordance with embodiments of the technology. Figure 5B is an isometric view of the vent stack lid 510. Referring to Figures 5A and 5B together, the lid 510 comprises a first lid portion 512 at least partially overlapping a second lid portion 514. In this sense, the sealing system is integral to the lid 510. The first lid portion 512 overlaps the second lid portion 514 at region 582. In further embodiments, the overlap region 582 can be larger or smaller. In the illustrated embodiment, the first lid portion 512 includes a rise at region 580 over the overlap region 582, but in further embodiments the upper surfaces of the first and second lid portions 512, 514 can be coplanar. The first lid portion 512 can further comprise an upside-down U-shape that can overlap or seal side portions of the second lid portion. For example, side region 584 of the first lid portion covers or overlaps a side portion of the second lid portion 514. In further embodiments, the first and second lid portions 512, 514 can have other complementary shapes.

[0030] The first and/or second lid portions 512, 514 can be pivotably coupled (i.e., with a hinge) to the vent stack 202. In further embodiments, the lid portions 512, 514 are slideably coupled or otherwise movable relative to the vent stack 202. The first and second lid portions 512, 514 can be cast refractory, steel, ceramic, or any other suitable material. The first and/or second lid portions 512, 514 can further include any materials or combinations of flexible, soft, rigid, hard, permeable, or impermeable materials described above. For example, in a particular embodiment, the first lid portion 512 further includes a soft or flexible insulating layer covering at least part of the overlap region 582 to further enhance the seal. In still further embodiments, any of the materials described above can be positioned under the first and second lid portions 512, 514, and on the vent stack 202 to further improve sealing. In other embodiments, other surfaces of the vent stack 202 can

have additional sealing features (e.g., a blanket lining on an exterior or interior surface of the vent stack 202) to improve insulation or sealing.

Examples

1. A vent stack lid, comprising:
a first lid portion proximate to and at least partially spaced apart from a second lid portion;
a first sealing portion coupled to the first lid portion; and
a second sealing portion coupled to the second lid portion, wherein the second sealing portion at least partially overlaps the first sealing portion over the space between the first and second lid portions.
2. The vent stack lid of example 1 wherein the first sealing portion comprises a first tadpole seal and the second sealing portion comprises a second tadpole seal, and wherein the first tadpole seal and second tadpole seal are in adjacent contact and are substantially positioned in the space between the first and second lid portions.
3. The vent stack lid of example 1 wherein the first sealing portion comprises a first spring seal and the second sealing portion comprises a second spring seal, and wherein the first spring seal and second spring seal are in adjacent contact and are positioned above the space between the first and second lid portions.
4. The vent stack lid of example 3 wherein the first spring seal and second spring seal are laterally offset from the space between the first lid portion and second lid portion.
5. The vent stack lid of example 1 wherein at least one of the first sealing portion or second sealing portion comprises a generally flexible, heat-resistant blanket.
6. The vent stack lid of example 1 wherein at least one of the first sealing portion or second sealing portion comprises a generally rigid refractory material.

7. The vent stack lid of example 1 wherein the first lid portion and the second lid portion are individually pivotably movable between a closed configuration and an open configuration.

8. The vent stack lid of example 1 wherein the second sealing portion is pivotably or slidably coupled to the second lid portion.

9. The vent stack lid of example 1 wherein at least one of the first sealing portion and second sealing portion comprise a generally rigid framework made of stainless steel, ceramic, or refractory material.

10. A vent stack system, comprising:

a lid comprising a first lid portion at least partially spaced apart from a second lid portion;

and

a sealing system coupled to at least one of the first lid portion or the second lid portion and at least partially positioned in or over the space between the first lid portion and the second lid portion, the sealing system comprising a plurality of layers of materials, wherein at least two individual layers have different rigidity, hardness, or permeability properties from one another.

11. The vent stack system of example 10 wherein at least two layers overlap the space between the first lid portion and the second lid portion.

12. The vent stack system of example 10 wherein at least one layer comprises a tadpole seal, a spring seal, cast refractory, or a thermal blanket.

13. The vent stack system of example 10 wherein the plurality of layers comprises a generally flexible material adjacent to a generally rigid material.

14. The vent stack system of example 10 wherein the sealing system comprises a fastener configured to allow pivoting or sliding movement of at least a portion of the sealing system relative to the first lid portion.

15. A method of sealing a vent stack, the method comprising:
positioning a generally flexible, heat-resistant material in or proximate to a space between a first vent stack lid portion and a second vent stack lid portion;
positioning a generally rigid, heat-resistant material adjacent to the generally flexible material; and
inhibiting gas from traversing the space between the first lid portion and the second lid portion.

16. The method of example 15 wherein the first lid portion comprises a top portion and a sidewall portion, and wherein positioning the generally flexible, heat-resistant material comprises positioning the generally flexible, heat-resistant material along at least one of the top portion or the sidewall portion.

17. The method of example 15, further comprising positioning a plurality of tadpole seals in the space between the first lid portion and the second lid portion.

18. The method of example 17, further comprising overlapping the tadpole seals with at least one of the generally flexible, heat resistant material or the generally rigid, heat-resistant material.

19. The method of example 15 wherein positioning the generally flexible, heat-resistant material comprises pivoting or sliding the material into the space between the first vent stack lid portion and the second vent stack lid portion.

20. The method of example 15, further comprising positioning a plurality of spring seals above the space between the first vent stack lid portion and the second vent stack lid portion.

[0031] The systems and methods disclosed herein offer several advantages over traditional coke oven systems. The sealing systems can provide more reliable containment of exhaust gas in the vent stack and can prevent atmospheric air from entering the stack. The sealing systems can provide several thermal-resistant seal layers to provide a tighter seal as compared to traditional systems. Since the sealing structures include several layers of high-temperature-resistant materials, the sealing features can last longer than traditional seals without burning off. Longer lasting seals accordingly require less maintenance which can lower operation costs and increase throughput. The sealing systems can also include overlapping seals, which further stop gas movement in and out of the vent stack. The overlapping seals additionally provide a moving allowance to accommodate movement of the stack lid portions (e.g., movement away from each other over time).

[0032] From the foregoing it will be appreciated that, although specific embodiments of the technology have been described herein for purposes of illustration, various modifications may be made without deviating from the spirit and scope of the technology. For example, while the sealing systems have been discussed in the context of vent stack lids, they can be used on the tops, sides, or other surfaces of any commercial, high-temperature vent stacks or other structures operating under positive or negative pressure. Further, certain aspects of the new technology described in the context of particular embodiments may be combined or eliminated in other embodiments. Moreover, while advantages associated with certain embodiments of the technology have been described in the context of those embodiments, other embodiments may also exhibit such advantages, and not all embodiments need necessarily exhibit such advantages to fall within the scope of the technology. Accordingly, the disclosure and associated technology can encompass other embodiments not expressly shown or described herein. Thus, the disclosure is not limited except as by the appended claims.

CLAIMS

I/We claim:

1. A vent stack lid, comprising:
a first lid portion proximate to and at least partially spaced apart from a second lid portion;
a first sealing portion coupled to the first lid portion; and
a second sealing portion coupled to the second lid portion, wherein the second sealing portion at least partially overlaps the first sealing portion over the space between the first and second lid portions.
2. The vent stack lid of claim 1 wherein the first sealing portion comprises a first tadpole seal and the second sealing portion comprises a second tadpole seal, and wherein the first tadpole seal and second tadpole seal are in adjacent contact and are substantially positioned in the space between the first and second lid portions.
3. The vent stack lid of claim 1 wherein the first sealing portion comprises a first spring seal and the second sealing portion comprises a second spring seal, and wherein the first spring seal and second spring seal are in adjacent contact and are positioned above the space between the first and second lid portions.
4. The vent stack lid of claim 3 wherein the first spring seal and second spring seal are laterally offset from the space between the first lid portion and second lid portion.
5. The vent stack lid of claim 1 wherein at least one of the first sealing portion or second sealing portion comprises a generally flexible, heat-resistant blanket.
6. The vent stack lid of claim 1 wherein at least one of the first sealing portion or second sealing portion comprises a generally rigid refractory material.

7. The vent stack lid of claim 1 wherein the first lid portion and the second lid portion are individually pivotably movable between a closed configuration and an open configuration.

8. The vent stack lid of claim 1 wherein the second sealing portion is pivotably or slidably coupled to the second lid portion.

9. The vent stack lid of claim 1 wherein at least one of the first sealing portion and second sealing portion comprise a generally rigid framework made of stainless steel, ceramic, or refractory material.

10. A vent stack system, comprising:

a lid comprising a first lid portion at least partially spaced apart from a second lid portion;
and

a sealing system coupled to at least one of the first lid portion or the second lid portion and at least partially positioned in or over the space between the first lid portion and the second lid portion, the sealing system comprising a plurality of layers of materials, wherein at least two individual layers have different rigidity, hardness, or permeability properties from one another.

11. The vent stack system of claim 10 wherein at least two layers overlap the space between the first lid portion and the second lid portion.

12. The vent stack system of claim 10 wherein at least one layer comprises a tadpole seal, a spring seal, cast refractory, or a thermal blanket.

13. The vent stack system of claim 10 wherein the plurality of layers comprises a generally flexible material adjacent to a generally rigid material.

14. The vent stack system of claim 10 wherein the sealing system comprises a fastener configured to allow pivoting or sliding movement of at least a portion of the sealing system relative to the first lid portion.

15. A method of sealing a vent stack, the method comprising:
positioning a generally flexible, heat-resistant material in or proximate to a space between a first vent stack lid portion and a second vent stack lid portion;
positioning a generally rigid, heat-resistant material adjacent to the generally flexible material; and
inhibiting gas from traversing the space between the first lid portion and the second lid portion.

16. The method of claim 15 wherein the first lid portion comprises a top portion and a sidewall portion, and wherein positioning the generally flexible, heat-resistant material comprises positioning the generally flexible, heat-resistant material along at least one of the top portion or the sidewall portion.

17. The method of claim 15, further comprising positioning a plurality of tadpole seals in the space between the first lid portion and the second lid portion.

18. The method of claim 17, further comprising overlapping the tadpole seals with at least one of the generally flexible, heat resistant material or the generally rigid, heat-resistant material.

19. The method of claim 15 wherein positioning the generally flexible, heat-resistant material comprises pivoting or sliding the material into the space between the first vent stack lid portion and the second vent stack lid portion.

20. The method of claim 15, further comprising positioning a plurality of spring seals above the space between the first vent stack lid portion and the second vent stack lid portion.

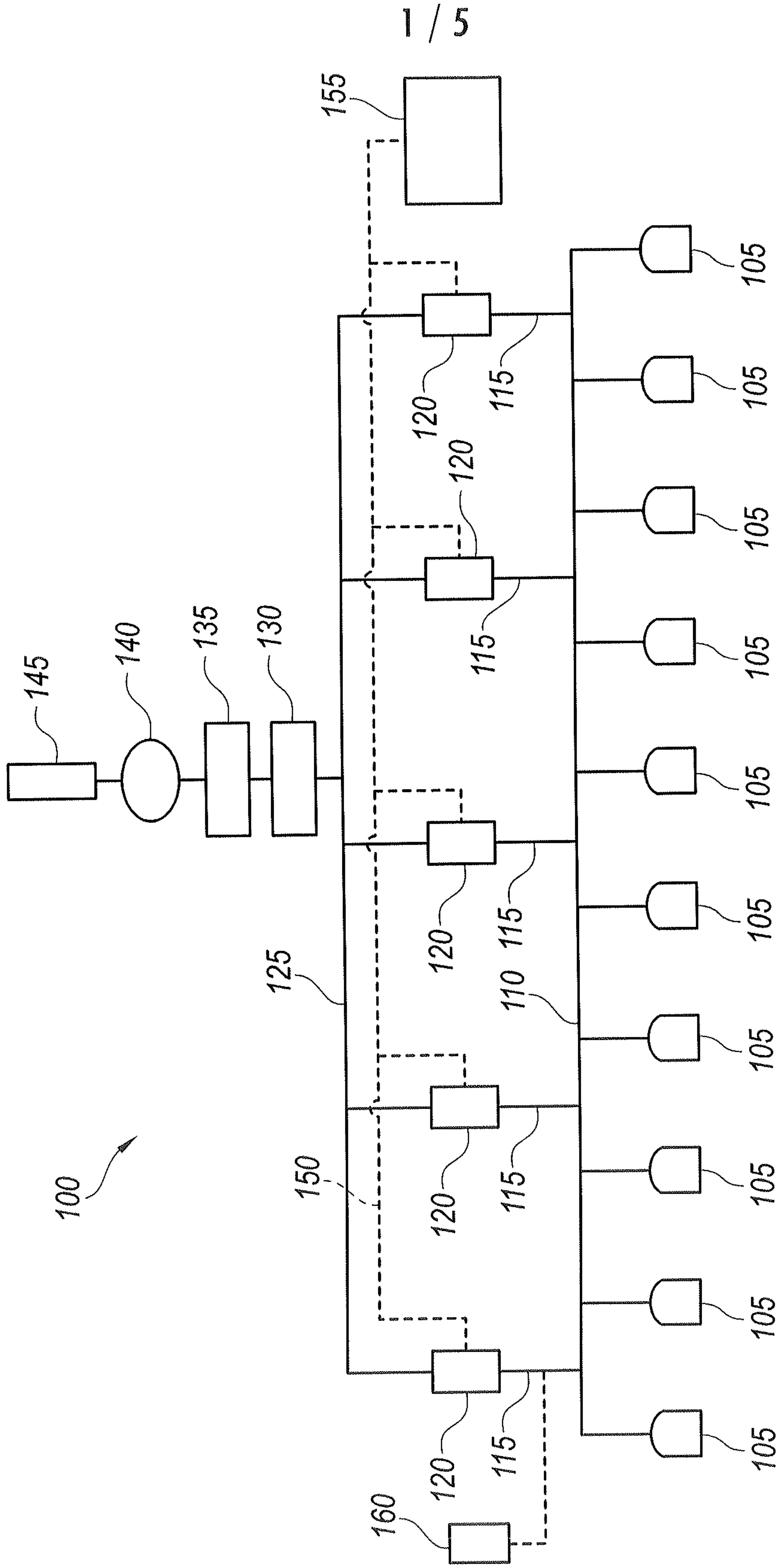

Fig. 1

2 / 5

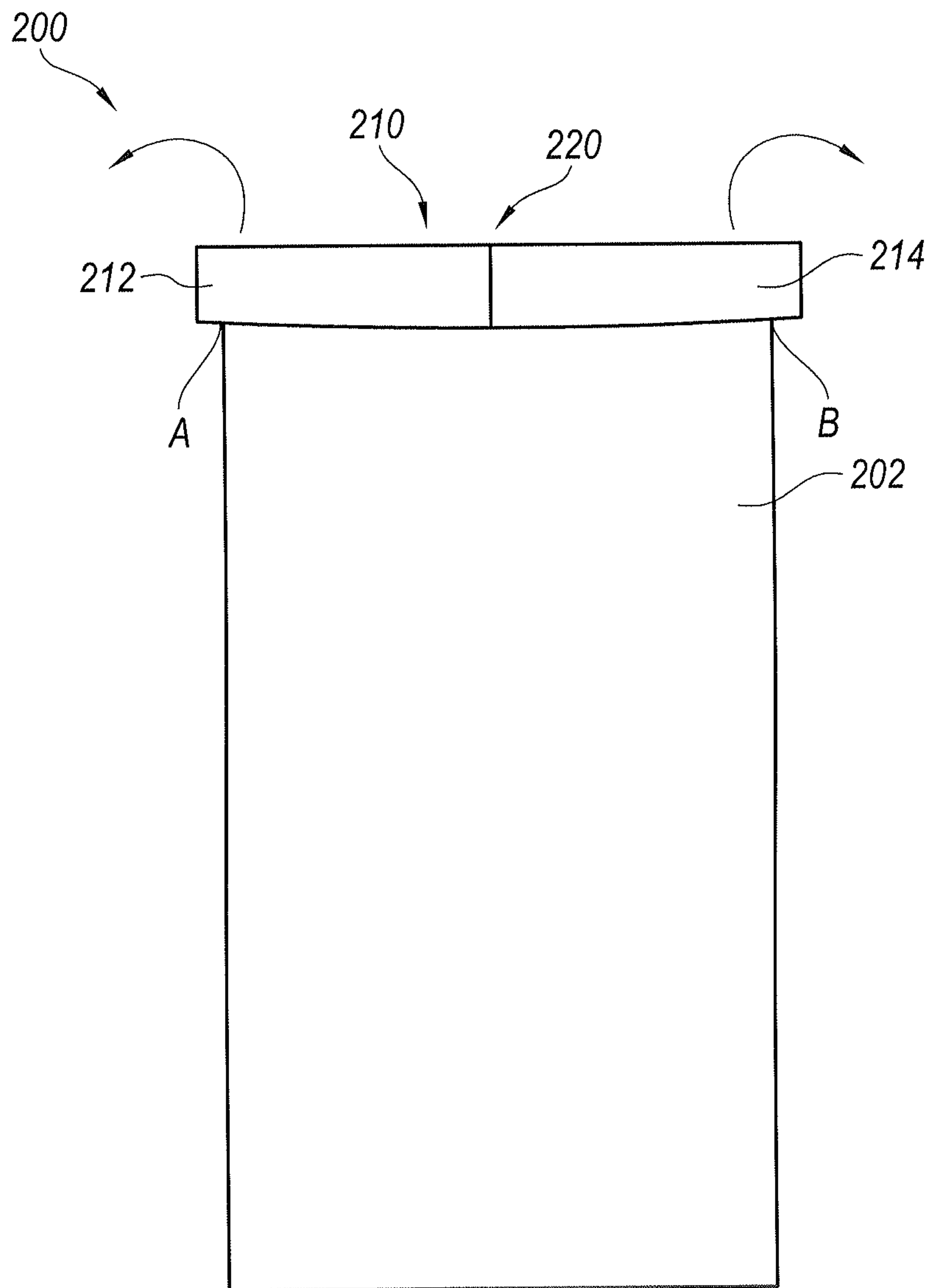

Fig. 2

3 / 5

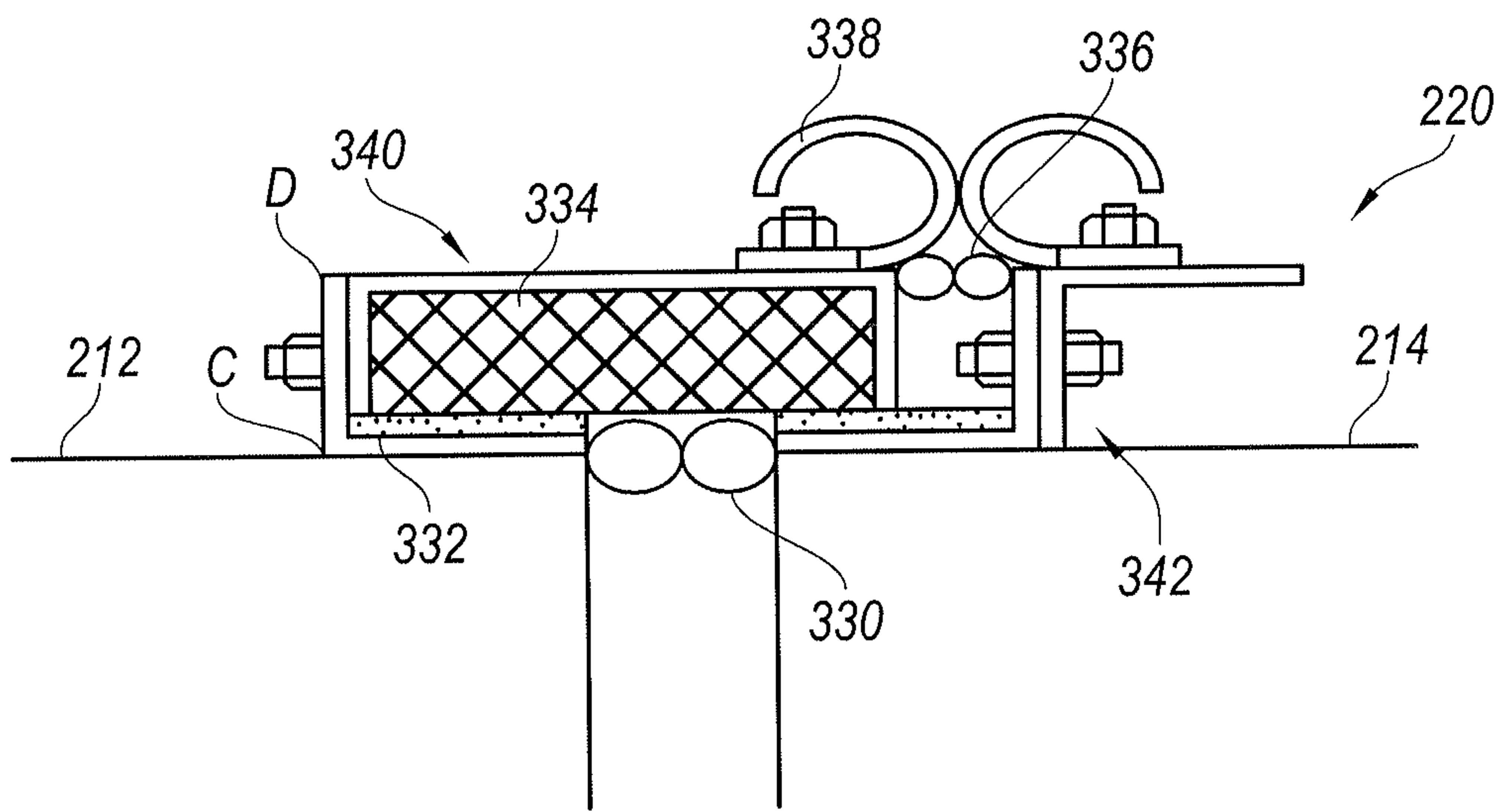

Fig. 3

4 / 5

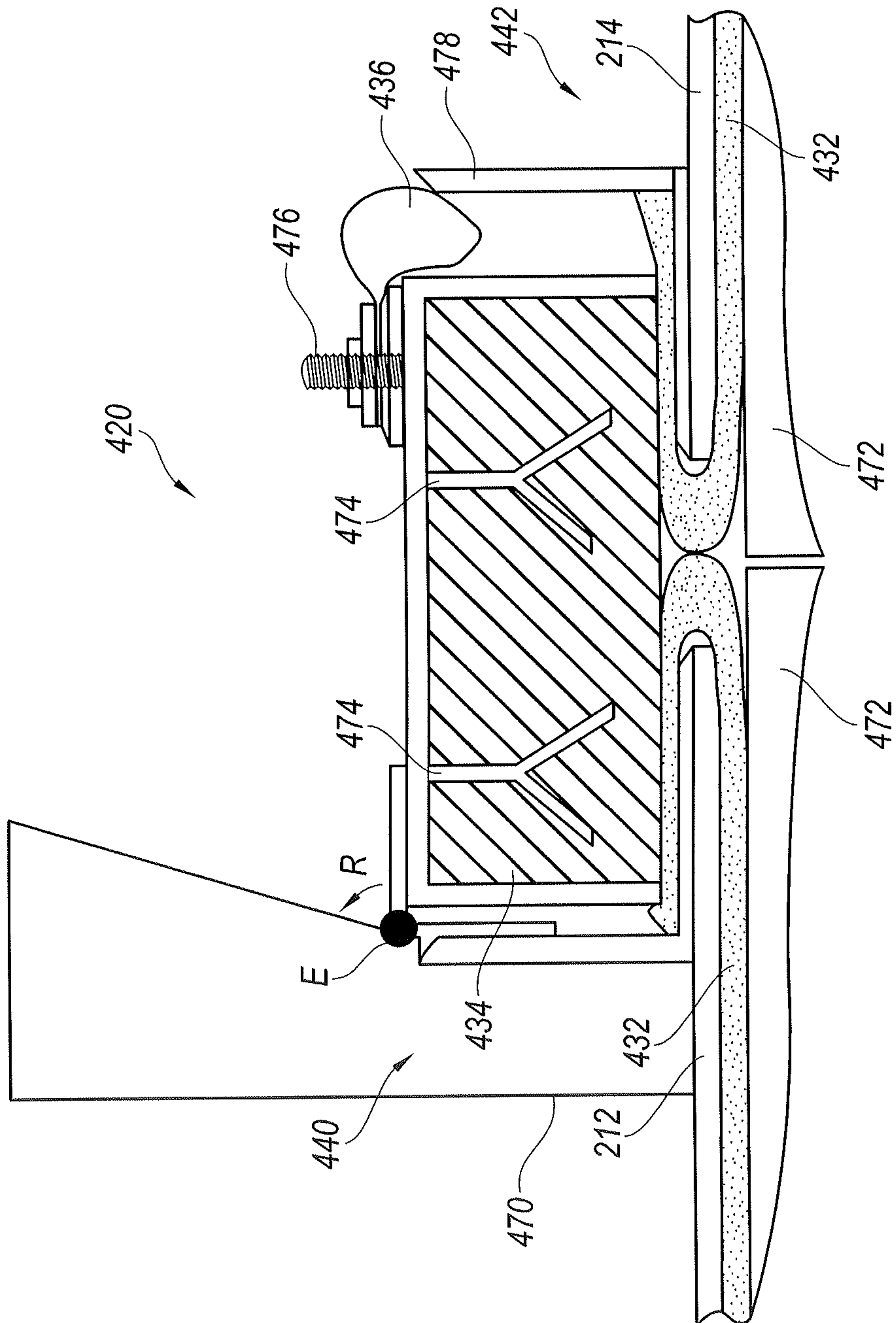

Fig. 4

5 / 5

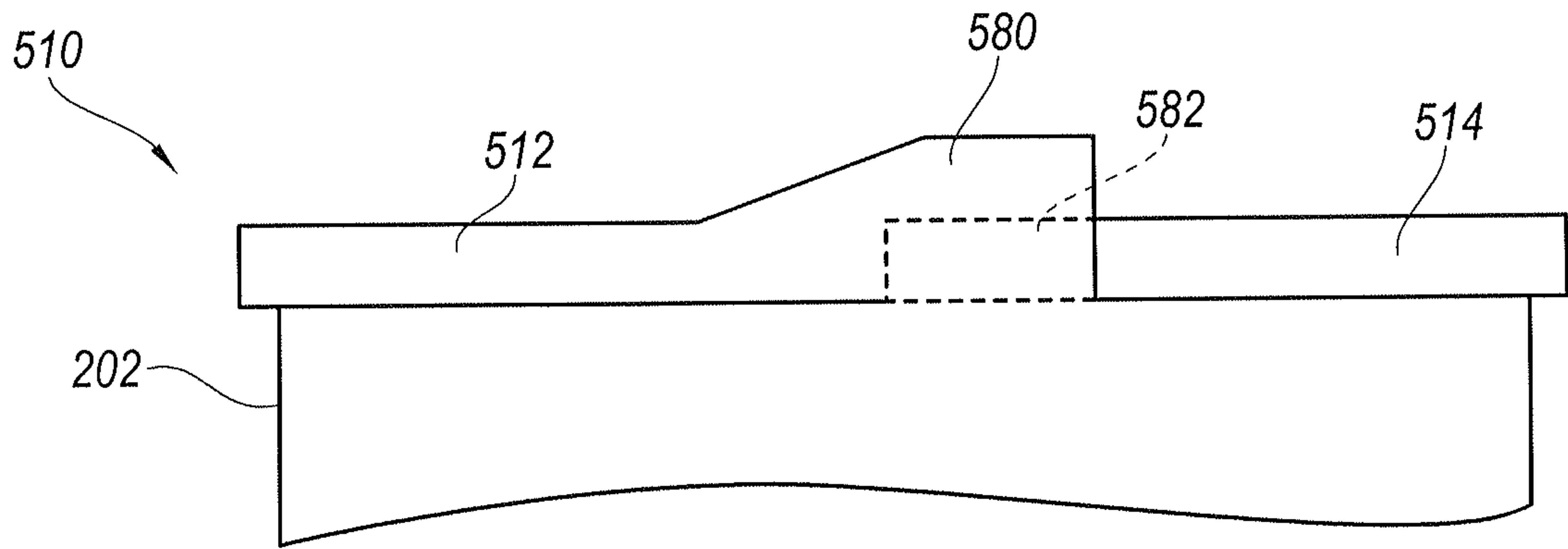

Fig. 5A

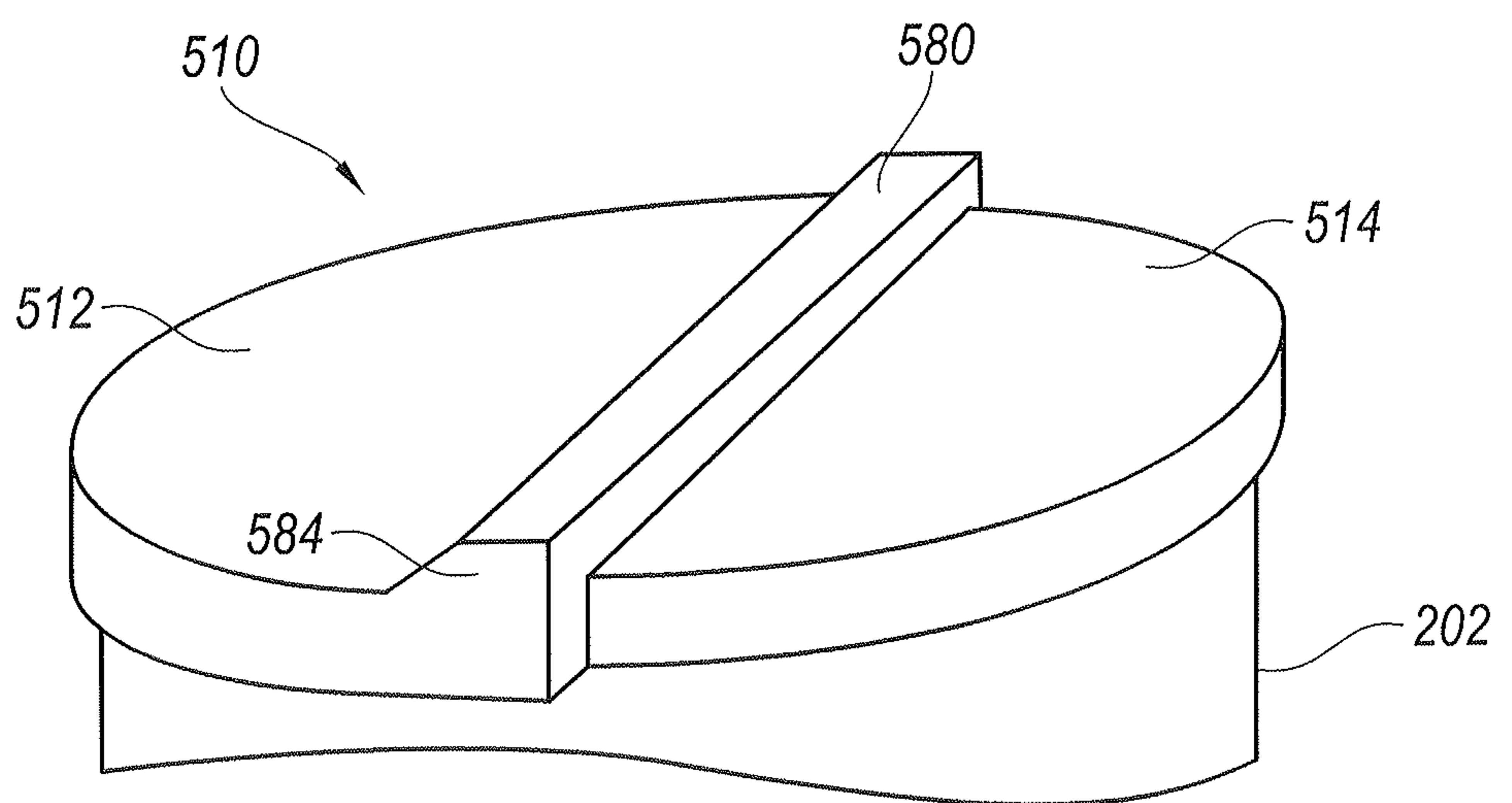

Fig. 5B

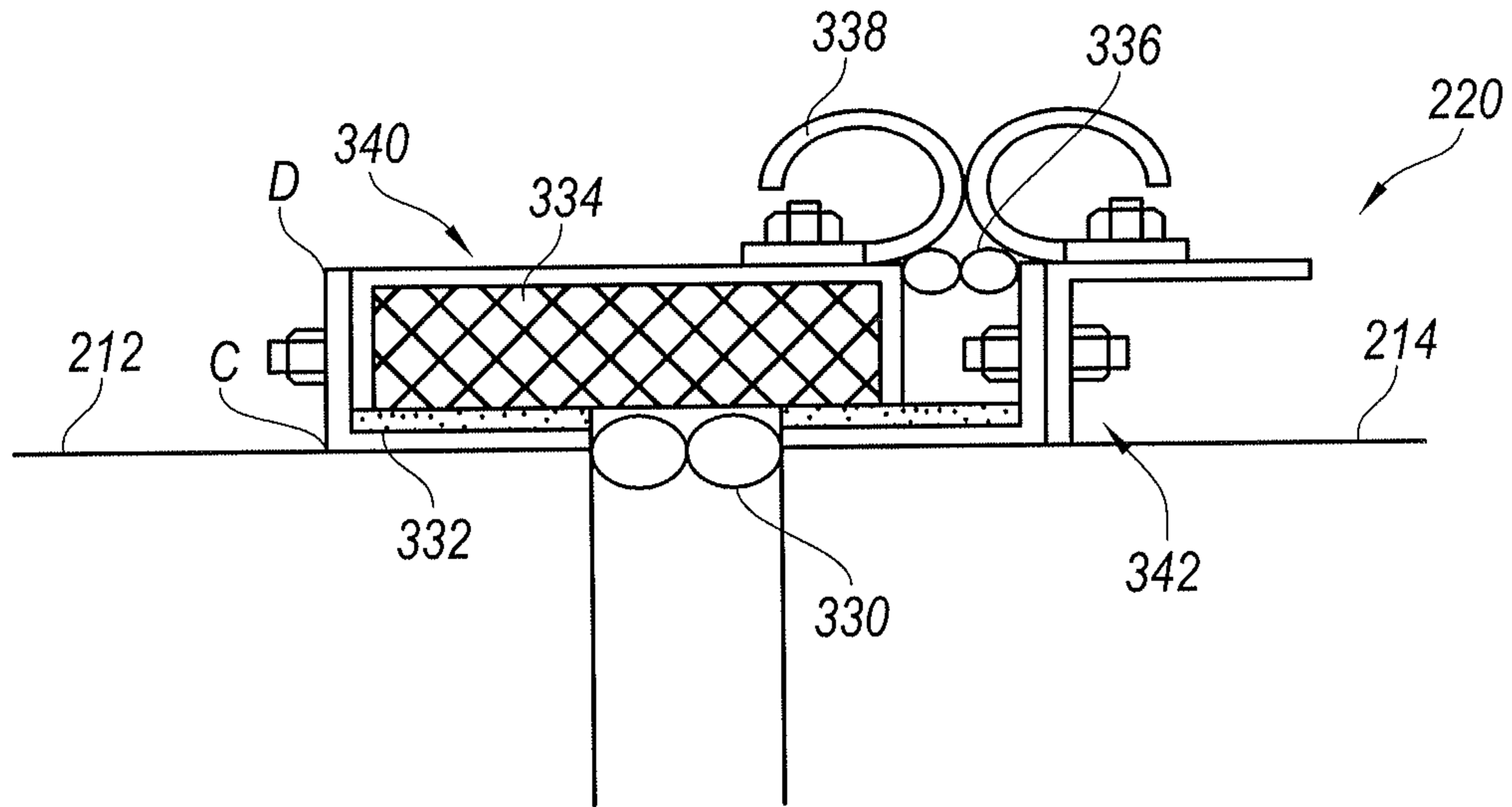

Fig. 3