

(12) **UK Patent Application** (19) **GB** (11) **2468438** (13) **A**

(43) Date of Reproduction by UK Office **08.09.2010**

(21) Application No: **1010144.2**  
 (22) Date of Filing: **18.12.2008**  
 (30) Priority Data:  
 (31) **11967176** (32) **29.12.2007** (33) **US**  
 (86) International Application Data:  
**PCT/US2008/087421 En 18.12.2008**  
 (87) International Publication Data:  
**WO2009/085949 En 09.07.2009**

(51) INT CL:  
**F01D 11/00 (2006.01)**  
 (56) Documents Cited by ISA:  
**EP 1445537 A EP 1296023 A**  
**WO 2001/071175 A US 6431555 A**  
**US 5797723 A US 5118120 A**  
 (58) Field of Search by ISA:  
 INT CL **F01D**  
 Other: **EPO-Internal, WPI Data**

(71) Applicant(s):  
**General Electric Company**  
**(Incorporated in USA - New York)**  
**One River Road, Schenectady, New York 12345,**  
**United States of America**  
 (72) Inventor(s):  
**Clive Andrew Morgan**  
**Todd Stephen Heffron**  
**Sanjeewa Thusitha Fonseka**  
 (74) Agent and/or Address for Service:  
**GE International Inc.**  
**15 John Adam Street, LONDON, WC2N 6LU,**  
**United Kingdom**

(54) Title of the Invention: **Turbine nozzle segment**  
 Abstract Title: **Turbine nozzle segment**

(57) A turbine nozzle segment includes a band (124) having a plurality of tabs (152), an airfoil extending from the band and a support structure (166) attached to the tabs. The support structure has a plurality of biasing structures (168).

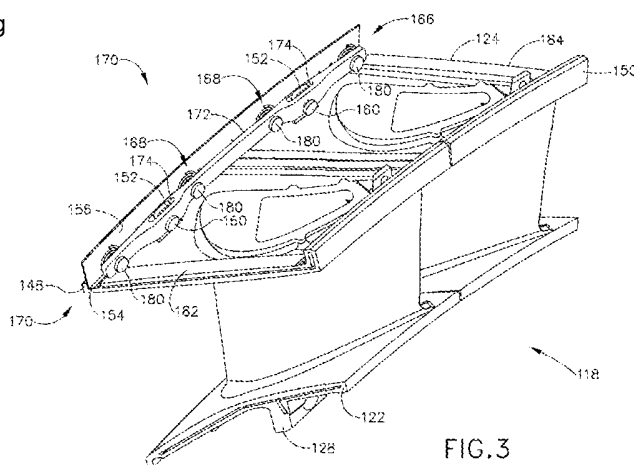

**GB 2468438 A**