

(19) AUSTRALIAN PATENT OFFICE

(54) Title
Improvements relating to contact-less power transfer

(51)⁶ International Patent Classification(s)
H02J 7/00 (2006.01) 27/25
H01F 3/02 (2006.01) 20060101ALI2008121
H01F 5/00 (2006.01) 0BMAU H01F
H01F 27/25 (2006.01) 27/28
H01F 27/28 (2006.01) 20060101ALI2008121
H01F 38/14 (2006.01) 0BMAU H01F
H01F 41/02 (2006.01) 38/14
H02J 7/02 (2006.01) 20060101ALI2008121
H02J 17/00 (2006.01) 0BMAU H01F
H02J 7/00 41/02
20060101AFI2008121 20060101ALI2008121
0BMAU H01F 0BMAU H02J
3/02 7/02
20060101ALI2008121 20060101ALI2008121
0BMAU H01F 0BMAU H02J
5/00 17/00
20060101ALI2008121 20060101ALI2008121
0BMAU H01F 0BMAU

(21) Application No: 2008255158

(22) Application Date: 2008.12.05

(43) Publication Date : 2009.01.08

(43) Publication Journal Date : 2009.01.08

(62) Divisional of:
2003233895

(71) Applicant(s)
Amway (Europe) Limited

(72) Inventor(s)
Hay, James W.; Cheng, Lily Ka Lai; Beart, Pilgrim Giles William

(74) Agent/Attorney
Watermark Patent & Trademark Attorneys, 302 Burwood Road, Hawthorn, VIC, 3122

ABSTRACT

There is disclosed a system and method for transferring power without requiring direct electrical conductive contacts. There is provided a primary unit
5 having a power supply and a substantially laminar charging surface having at least one conductor that generates an electromagnetic field when a current flows therethrough and having an charging area defined within a perimeter of the surface, the at least one conductor being arranged such that electromagnetic field lines generated by the at least one conductor are substantially parallel to the
10 plane of the surface or at least subtend an angle of 45° or less to the surface within the charging area; and at least one secondary device including at least one conductor that may be wound about a core. Because the electromagnetic field is spread over the charging area and is generally parallel or near-parallel thereto, coupling with flat secondary devices such as mobile telephones and the like is
15 significantly improved in various orientations thereof.

2008255158 05 Dec 2008

P001
Section 29
Regulation 3.2(2)

AUSTRALIA
Patents Act 1990

COMPLETE SPECIFICATION STANDARD PATENT

Application Number:

Lodged:

Invention Title: **Improvements relating to contact-less power transfer**

The following statement is a full description of this invention, including the best method of performing it known to us:

P111AHAU/1107

IMPROVEMENTS RELATING TO CONTACT-LESS POWER TRANSFER

The present application claims priority from UK patent applications nos 0210886.8 of 13th May 2002, 0213024.3 of 7th June 2002, 0225006.6 of 28th
5 October 2002 and 0228425.5 of 6th December 2002, as well as from US patent application no 10/326,571 of 20 December 2002. The full contents of all of these prior patent applications is hereby incorporated into the present application by reference.

FIELD OF THE INVENTION

10 This invention relates to a new apparatus and method for transferring power in a contact-less fashion.

BACKGROUND TO THE INVENTION

Many of today's portable devices incorporate "secondary" power cells which can be recharged, saving the user the cost and inconvenience of regularly
15 having to purchase new cells. Example devices include cellular telephones, laptop computers, the Palm 500 series of Personal Digital Assistants, electric shavers and electric toothbrushes.

In some of these devices, the cells are recharged via inductive coupling rather than direct electrical connection. Examples include the Braun Oral B Plak
20 Control power toothbrush, the Panasonic Digital Cordless Phone Solution KX-PH15AL and the Panasonic multi-head men's shavers ES70/40 series.

Each of these devices typically has an adaptor or charger which takes power from mains electricity, a car cigarette lighter or other sources of power and converts it into a form suitable for charging the secondary cells. There are a
25 number of problems associated with conventional means of powering or charging these devices:

- Both the characteristics of the cells within each device and the means of connecting to them vary considerably from manufacturer to manufacturer, and from device to device. Therefore users who own several such devices must
30 also own several different adaptors. If users are going away on travel, they will have to bring their collection of chargers if they expect to use their devices during this time.

- These adaptors and chargers often require users to plug a small connector into the device or to place the device with accurate alignment into a stand causing inconvenience. If users fail to plug or place their device into a charger and it runs out of power, the device becomes useless and important data stored locally in the device might even be lost.
- In addition, most adaptors and chargers have to be plugged into mains sockets and hence if several are used together, they take up space in plug strips and create a messy and confusing tangle of wires.
- Besides the above problems with conventional methods of recharging devices, there are also practical problems associated with devices having an open electrical contact. For example, devices cannot be used in wet environments due to the possibility of corroding or shorting out the contacts and also they cannot be used in flammable gaseous environments due to the possibility of creating electrical sparks.

Chargers which use inductive charging remove the need to have open electrical contacts hence allowing the adaptor and device to be sealed and used in wet environments (for example the electric toothbrush as mentioned above is designed to be used in a bathroom). However such chargers still suffer from all other problems as described above. For example, the devices still need to be placed accurately into a charger such that the device and the charger are in a predefined relative position (See Figures 1a and 1b). The adaptors are still only designed specifically for a certain make and model of device and are still only capable of charging one device at a time. As a result, users still need to possess and manage a collection of different adaptors.

Universal chargers (such as the Maha MH-C777 Plus Universal charger) also exist such that battery packs of different shapes and characteristics can be removed from the device and charged using a single device. Whilst these universal chargers eliminate the need for having different chargers for different devices, they create even more inconvenience for the user in the sense that the battery packs first need to be removed, then the charger needs to be adjusted and the battery pack needs to be accurately positioned in or relative to the charger. In addition, time must be spent to determine the correct pair of battery pack metal contacts which the charger must use.

5 It is known from US 3,938, 018 "Induction charging system" to provide a means for non-contact battery charging whereby an inductive coil on the primary side aligns with a horizontal inductive coil on a secondary device when the device is placed into a cavity on the primary side. The cavity ensures the relatively precise alignment which is necessary with this design to ensure that good coupling is achieved between the primary and secondary coils.

10 It is also known from US 5,959, 433 "Universal Inductive Battery Charger System" to provide a non-contact battery charging system. The battery charger described includes a single charging coil which creates magnetic flux lines which will induce an electrical current in a battery pack which may belong to cellular phones or laptop computers.

15 It is also known from US 4,873, 677 "Charging Apparatus for an Electronic Device" to provide an apparatus for charging an electronic device which includes a pair of coils. This pair of coils is designed to operate in anti-phase such that magnetic flux lines are coupled from one coil to the other. An electronic device such as a watch can be placed on these two coils to receive power.

20 It is also known from US 5,952, 814 "Induction charging apparatus and an electronic device" to provide an induction charger for charging a rechargeable battery. The shape of the external casing of the electronic device matches the internal shape of the charger thus allowing for accurate alignment of the primary and secondary coils.

It is also known from US 6,208, 115 "Battery substitute pack" to provide a substitute battery pack which may be inductively recharged.

25 It is known from WO 00/61400 "Device for Inductively Transmitting Electrical Power" to provide a means of transferring power inductively to conveyors.

It is known from WO 95/11545 "Inductive power pick-up coils" to provide a system for inductive powering of electric vehicles from a series of in-road flat primaries.

30 To overcome the limitations of inductive power transfer systems which require that secondary devices be axially aligned with the primary unit, one might propose that an obvious solution is to use a simple inductive power transfer system whereby the primary unit is capable of emitting an electromagnetic field

over a large area (See Figure 2a). Users can simply place one or more devices to be recharged within range of the primary unit, with no requirement to place them accurately. For example this primary unit may consist of a coil encircling a large area. When a current flows through the coil, an electromagnetic field extending over a large area is created and devices can be placed anywhere within this area. Although theoretically feasible, this method suffers from a number of drawbacks. Firstly, the intensity of electromagnetic emissions is governed by regulatory limits. This means that this method can only support power transfer at a limited rate. In addition, there are many objects that can be affected by the presence of an intense magnetic field. For example, data stored on credit cards maybe destroyed and objects made of metal will have induced therein eddy currents generating undesired heating effects. In addition, if a secondary device comprising a conventional coil (see Figure 2a) is placed against a metallic plate such as a copper plane in a printed circuit board or metallic can of a cell, coupling is likely to be significantly reduced.

To avoid the generation of large magnetic fields, one might suggest using an array of coils (See Figure 3) whereby only the coils needed are activated. This method is described in a paper published in the Journal of the Magnetics Society of Japan titled "Coil Shape in a Desk-type Contactless Power Station System" (29 Nov 2001). In an embodiment of the multiple-coil concept, a sensing mechanism senses the relative location of the secondary device relative to the primary unit. A control system then activates the appropriate coils to deliver power to the secondary device in a localised fashion. Although this method provides a solution to the problems previously listed, it does so in a complicated and costly way. The degree to which the primary field can be localised is limited by the number of coils and hence the number of driving circuits used (i. e. the "resolution" of the primary unit). The cost associated with a multiple-coil system would severely limit the commercial applications of this concept. Non-uniform field distribution is also a drawback. When all the coils are activated in the primary unit, they sum to an equivalent of a large coil, the magnetic field distribution of which is seen to exhibit a minimum at the centre of the coil.

Another scheme is outlined in US 5,519, 262 "Near Field Power Coupling System", whereby a primary unit has a number of narrow inductive coils (or

alternatively capacitive plates) arranged from one end to the other of a flat plate, creating a number of vertical fields which are driven in a phase-shifted manner so that a sinusoidal wave of activity moves across the plate. A receiving device has two vertical field pickups arranged so that regardless of its position on the plate it can always collect power from at least one pickup. While this scheme also offers freedom of movement of the device, it has the disadvantages of needing a complex secondary device, having a fixed resolution, and having poor coupling because the return flux path is through air.

None of the prior art solutions can satisfactorily address all of the problems that have been described. It would be convenient to have a solution which is capable of transferring power to portable devices with all of the following features and is cost effective to implement:

- Universality: a single primary unit which can supply power to different secondary devices with different power requirements thereby eliminating the need for a collection of different adaptors and chargers;
- Convenience : a single primary unit which allows secondary devices to be placed anywhere within an active vicinity thereby eliminating the need for plugging-in or placing secondary devices accurately relative to an adaptor or charger;
- Multiple-load : a single primary unit that can supply power to a number of secondary different devices with different power requirements at the same time;
- Flexibility for use in different environments: a single primary unit that can supply power to secondary devices such that no direct electrical contact is required thereby allowing for secondary devices and the primary unit itself to be used in wet, gaseous, clean and other atypical environments;
- Low electromagnetic emissions: a primary unit that can deliver power in a manner that will minimize the intensity and size of the magnetic field generated.

It is further to be appreciated that portable appliances are proliferating and they all need batteries to power them. Primary cells, or batteries of them, must be disposed of once used, which is expensive and environmentally unfriendly. Secondary cells or batteries can be recharged and used again and again.

Many portable devices have receptacles for cells of an industry-standard size and voltage, such as AA, AAA, C, D and PP3. This leaves the user free to choose whether to use primary or secondary cells, and of various types. Once depleted, secondary cells must typically be removed from the device and placed
5 into a separate recharging unit. Alternatively, some portable devices do have recharging circuitry built-in, allowing cells to be recharged in-situ once the device is plugged-in to an external source of power.

It is inconvenient for the user to have to either remove cells from the device for recharging, or to have to plug the device into an external power source
10 for recharging in-situ. It would be far preferable to be able to recharge the cells without doing either, by some non-contact means.

Some portable devices are capable of receiving power coupled inductively from a recharger, for example the Braun Oral B Plak Control toothbrush. Such portable devices typically have a custom, dedicated power-receiving module built-
15 in to the device, which then interfaces with an internal standard cell or battery (which may or may not be removable).

However it would be convenient if the user could transform any portable device which accepts industry-standard cell sizes into an inductively-rechargeable device, simply by fitting inductively-rechargeable cells or batteries, which could
20 then be recharged in-situ by placing the device onto an inductive recharger.

Examples of prior art include US 6, 208, 115, which discloses a substitute battery pack which may be inductively recharged.

SUMMARY OF THE INVENTION

According to a first aspect of the present invention, there is provided a
25 system for transferring power without requiring direct electrical conductive contacts, the system comprising :

i) a primary unit including a substantially laminar charging surface and at least one means for generating an electromagnetic field, the means being distributed in two dimensions across a predetermined area in or parallel to the
30 charging surface so as to define at least one charging area of the charging surface that is substantially coextensive with the predetermined area, the charging area having a width and a length on the charging surface, wherein the means is configured such that, when a predetermined current is supplied thereto

and the primary unit is effectively in electromagnetic isolation, an electromagnetic field generated by the means has electromagnetic field lines that, when averaged over any quarter length part of the charging area measured parallel to a direction of the field lines, subtend an angle of 45° or less to the charging surface in proximity thereto and are distributed in two dimensions thereover, and wherein the means has a height measured substantially perpendicular to the charging area that is less than either of the width or the length of the charging area; and

5
10
15
20
25
30
ii) at least one secondary device including at least one electrical conductor; wherein, when the at least one secondary device is placed on or in proximity to a charging area of the primary unit, the electromagnetic field lines couple with the at least one conductor of the at least one secondary device and induce a current to flow therein.

According to a second aspect of the present invention, there is provided a primary unit for transferring power without requiring direct electrical conductive contacts, the primary unit including a substantially laminar charging surface and at least one means for generating an electromagnetic field, the means being distributed in two dimensions across a predetermined area in or parallel to the charging surface so as to define at least one charging area of the charging surface that is substantially coextensive with the predetermined area, the charging area having a width and a length on the charging surface, wherein the means is configured such that, when a predetermined current is supplied thereto and the primary unit is effectively in electromagnetic isolation, an electromagnetic field generated by the means has electromagnetic field lines that, when averaged over any quarter length part of the charging area measured parallel to a direction of the field lines, subtend an angle of 45° or less to the charging surface in proximity thereto and are distributed in two dimensions thereover, and wherein the means has a height measured substantially perpendicular to the charging area that is less than either of the width or the length of the charging area.

According to a third aspect of the present invention, there is provided a method of transferring power in a non-conductive manner from a primary unit to a secondary device, the primary unit including a substantially laminar charging surface and at least one means for generating an electromagnetic field, the means being distributed in two dimensions across a predetermined area in or

parallel to the charging surface so as to define at least one charging area of the charging surface that is substantially coextensive with the predetermined area, the charging area having a width and a length on the charging surface, the means having a height measured substantially perpendicular to the charging area that is
5 less than either of the width or the length of the charging area, and the secondary device having at least one electrical conductor; wherein:

i) an electromagnetic field, generated by the means when energised with a predetermined current and measured when the primary unit is effectively in electromagnetic isolation, has electromagnetic field lines that, when averaged
10 over any quarter length part of the charging area measured parallel to a direction of the field lines, subtend an angle of 45° or less to the charging surface in proximity thereto and are distributed in two dimensions over the at least one charging area when averaged thereover; and

ii) the electromagnetic field links with the conductor of the secondary
15 device when this is placed on or in proximity to the charging area.

According to a fourth aspect of the present invention, there is provided a secondary device for use with the system, unit or method of the first, second or third aspects, the secondary device including at least one electrical conductor and having a substantially laminar form factor.

20 In the context of the present application, the word "laminar" defines a geometry in the form of a thin sheet or lamina. The thin sheet or lamina may be substantially flat, or may be curved.

The primary unit may include an integral power supply for the at least one means for generating an electromagnetic field, or may be provided with
25 connectors or the like enabling the at least one means to be connected to an external power supply.

In some embodiments, the means for generating the electromagnetic field have a height that is no more than half the width or half the length of the charging area; in some embodiments, the height may be no more than $1/5$ of the width or
30 $1/5$ of the length of the charging area.

The at least one electrical conductor in the secondary device may be wound about a core that serves to concentrate flux therein. In particular, the core (where provided) may offer a path of least resistance to flux lines of the

electromagnetic field generated by the primary unit. The core may be amorphous magnetically permeable material. In some embodiments, there is no need for an amorphous core.

5 Where an amorphous core is provided, it is preferred that the amorphous magnetic material is a non-annealed or substantially as-cast state. The material may be at least 70% non-annealed, or preferably at least 90% non-annealed. This is because annealing tends to make amorphous magnetic materials brittle, which is disadvantageous when contained in a device, such as a mobile phone, which may be subjected to rough treatment, for example by being accidentally
10 dropped. In a particularly preferred embodiment, the amorphous magnetic material is provided in the form of a flexible ribbon, which may comprise one or more layers of one or more of the same or different amorphous magnetic materials. Suitable materials include alloys which may contain iron, boron and silicon or other suitable materials. The alloy is melted and then cooled so rapidly
15 ("quenched") that there is no time for it to crystallise as it solidifies, thus leaving the alloy in a glass-like amorphous state. Suitable materials include Metglas® 2714A and like materials. Permalloy or mumetal or the like may also be used.

The core in the secondary device, where provided, is preferably a high magnetic permeability core. The relative permeability of this core is preferably at
20 least 100, even more preferably at least 500, and most preferably at least 1000, with magnitudes of at least 10,000 or 100,000 being particularly advantageous.

The at least one means for generating an electromagnetic field may be a coil, for example in the form of a length of wire or a printed strip, or may be in the form of a conductive plate of appropriate configuration, or may comprise any
25 appropriate arrangement of conductors. A preferred material is copper, although other conductive materials, generally metals, may be used as appropriate. It is to be understood that the term "coil" is here intended to encompass any appropriate electrical conductor forming an electrical circuit through which current may flow and thus generate an electromagnetic field. In particular, the "coil" need not be
30 wound about a core or former or the like, but may be a simple or complex loop or equivalent structure.

Preferably, the charging area of the primary unit is large enough to accommodate the conductor and/or core of the secondary device in a plurality of orientations thereof.

5 In a particularly preferred embodiment, the charging area is large enough to accommodate the conductor and/or core of the secondary device in any orientation thereof. In this way, power transfer from the primary unit to the secondary device may be achieved without having to align the conductor and/or core of the secondary device in any particular direction when placing the secondary device on the charging surface of the primary unit.

10 The substantially laminar charging surface of the primary unit may be substantially planar, or may be curved or otherwise configured to fit into a predetermined space, such as a glove compartment of a car dashboard or the like. It is particularly preferred that the means for generating an electromagnetic field does not project or protrude above or beyond the charging surface.

15 A key feature of the means for generating an electromagnetic field in the primary unit is that electromagnetic field lines generated by the means, measured when the primary unit is effectively in magnetic isolation (i. e. when no secondary device is present on or in proximity to the charging surface), are distributed in two dimensions over the at least one charging area and subtend an angle of 45° or less to the charging area in proximity thereto (for example, less than the height or width of the charging area) and over any quarter length part of the charging area measured in a direction generally parallel to that of the field lines. The measurement of the field lines in this connection is to be understood as a measurement of the field lines when averaged over the quarter length of the charging area, rather than an instantaneous point measurement. In some
20 embodiments, the field lines subtend an angle of 30° or less, and in some embodiments are substantially parallel to at least a central part of the charging area in question. This is in stark contrast to prior art systems, where the field lines tend to be substantially perpendicular to a surface of a primary unit. By
25 generating electromagnetic fields that are more or less parallel to or at least have a significant resolved component parallel to the charging area, it is possible to control the field so as to cause angular variations thereof, in or parallel to the plane of the charging area, that help to avoid any stationary nulls in the
30

electromagnetic field that would otherwise reduce charging efficiency in particular orientations of the secondary device on the charging surface. The direction of the field lines may be rotated through a complete or partial circle, in one or both directions. Alternatively, the direction may be caused to "wobble" or fluctuate, or
5 may be switched between two or more directions. In more complex configurations, the direction of the field lines may vary as a Lissajous pattern or the like.

In some embodiments, the field lines may be substantially parallel to each other over any given charging area, or at least have resolved components in or
10 parallel to the plane of the charging area that are substantially parallel to each other at any given moment in time.

It is to be appreciated that one means for generating an electromagnetic field may serve to provide a field for more than one charging area ; also that more than one means may serve to provide a field for just one charging area. In other
15 words, there need not be a one-to-one correspondence of means for generating electromagnetic fields and charging areas.

The secondary device may adopt a substantially flat form factor with a core thickness of 2mm or less. Using a material such as one or more amorphous metal sheets, it is possible to have core thickness down to 1mm or less for applications
20 where size and weight is important. See Figure 7a.

In a preferred embodiment, the primary unit may include a pair of conductors having adjacent coplanar windings which have mutually substantially parallel linear sections arranged so as to produce a substantially uniform electromagnetic field extending generally parallel to or subtending an angle of 45°
25 or less to the plane of the windings but substantially at right angles to the parallel sections.

The windings in this embodiment may be formed in a generally spiral shape, comprising a series of turns having substantially parallel straight sections.

Advantageously, the primary unit may include first and second pairs of
30 conductors which are superimposed in substantially parallel planes with the substantially parallel linear sections of the first pair arranged generally at right angles to the substantially parallel linear sections of the second pair, and further comprising a driving circuit which is arranged to drive them in such a way as to

generate a resultant field which rotates in a plane substantially parallel to the planes of the windings.

According to a fifth aspect of the present invention, there is provided a system for transferring power in a contact-less manner consisting of :

5 a primary unit consisting of at least one electrical coil whereby each coil features at least one active area whereby two or more conductors are substantially distributed over this area in such a fashion that it is possible for a secondary device to be placed in proximity to a part of this active area where the net instantaneous current flow in a particular direction is substantially non-zero ;

10 at least one secondary device consisting of conductors wound around a high permeability core in such a fashion that it is possible for it to be placed in proximity to an area of the surface of the primary unit where the net instantaneous current flow is substantially non-zero;

15 whereby the at least one secondary device is capable of receiving power by means of electromagnetic induction when the central axis of the winding is in proximity to the active area of the primary unit, is substantially not perpendicular to the plane of the active area of primary unit and is substantially not parallel to the conductors in the active area of at least one of the coils of the primary unit.

20 Where the secondary device comprises an inductively rechargeable battery or cell, the battery or cell may have a primary axis and be capable of being recharged by an alternating field flowing in the primary axis of the battery or cell, the battery or cell consisting of :

- an enclosure and external electrical connections similar in dimensions to industry-standard batteries or cells
- 25 • an energy-storage means
- an optional flux-concentrating means
- a power-receiving means
- a means of converting the received power to a form suitable for delivery to outside the cell through the external electrical connections, or to recharge
- 30 the energy storage means, or both.

The proposed invention is a significant departure from the design of conventional inductive power transfer systems. The difference between

conventional systems and the proposed system is best illustrated by looking at their respective magnetic flux line patterns. (See Figure 2a and 4)

- 5 • Conventional System: In a conventional system (See Figure 2a), there is typically a planar primary coil which generates a magnetic field with flux lines coming out of the plane in a perpendicular fashion. The secondary device has typically a round or square coil that encircles some or all of these flux lines.
- 10 • Proposed system: In the proposed system, the magnetic field travels substantially horizontally across the surface of the plane (see Figure 4) instead of directly out of the plane as illustrated in Figure 2a. The secondary device hence may have an elongated winding wound around a magnetic core.

See Figure 7a and 7b. When the secondary device is placed on the primary unit, the flux lines would be attracted to travel through the magnetic core of the secondary device because it is the lowest reluctance path. This causes the secondary device and the primary unit to be coupled effectively. The secondary core and winding may be substantially flattened to form a very thin component.

15 In describing the invention, specific terminology will be resorted to for the sake of clarity. However, it is not intended that the invention be limited to the specific terms so selected and it is to be understood that each specific term includes all technical equivalents which operate in a similar manner to accomplish a similar purpose.

25 It is to be understood that the term "charging area" used in this patent application may refer to the area of the at least one means for generating a field (e. g. one or more conductors in the form of a coil) or an area formed by a combination of primary conductors where the secondary device can couple flux effectively. Some embodiments of this are shown in Figures 6a to 6i and 9c as component 740. A feature of a "charging area" is a distribution of conductors over a significant area of the primary unit configured such that it is possible for the at least one means for generating a field to be driven to achieve an instantaneous net flow of flux in one direction. A primary unit may have more than one charging area. One charging area is distinct from another charging area when flux cannot

30

be effectively coupled by the secondary device (such as those shown in Figure 7a)-in any rotation at the boundary.

It is to be understood that the term "coil" used in this patent refers to all conductor configurations which feature a charging area as described above. This includes windings of wire or printed tracks or a plane as shown in Figure 8e. The conductors may be made of copper, gold, alloys or any other appropriate material.

The present application refers to the rotation of a secondary device in several places. It is to be clarified here that if a secondary device is rotated, the axis of rotation being referred to is the one perpendicular to the plane of the charging area.

This radical change in design overcomes a number of drawbacks of conventional systems. The benefits of the proposed invention include:

- No need for accurate alignment: The secondary device can be placed anywhere on a charging area of the primary unit;
- Uniform coupling: In the proposed invention, the coupling between the primary unit and secondary device is much more uniform over the charging area compared to a conventional primary and secondary coil. In a conventional large coil system (see Figure 2a), the field strength dips to a minimum at the centre of the coil, in the plane of the coil (see Figure 2b). This implies that if sufficient power is to be effectively transferred at the centre, the field strength at the minimum has to be above a certain threshold. The field strength at the maximum will then be excessively higher than the required threshold and this may cause undesirable effects.
- Universality : a number of different secondary devices, even those having different power requirements, can be placed within charging areas on the charging surface of the primary unit to receive power simultaneously.
- Increased coupling efficiency : Optional high permeability magnetic material present in the secondary device increases the induced flux significantly by offering a low reluctance path. This can significantly increase the power transfer.
- Desirable form factor for secondary device: The geometry of the system allows thin sheets of magnetic material (such as amorphous metal ribbons)

to be used. This means that secondary devices can have the form factor of a thin sheet, making it suitable to be incorporated at the back of mobile phones and other electronic devices. If magnetic material was to be used in the centre of conventional coils, it is likely to increase the bulkiness of the secondary device.

5

- Minimised field leakage: When one or more secondary devices are present in the charging area of the primary unit, it is possible to use magnetic material in such a way that more than half of the magnetic circuit is low reluctance magnetic material (see figure 4d). This means that more flux flows for a given magneto-motive force (mmf). As the induced voltage is proportional to the rate of change of flux linked, this will increase the power transfer to the secondary device. The fewer and shorter the air gaps are in the magnetic circuit, the less the field will fringe, the closer the flux is kept to the surface of the primary unit and hence leakage is minimized.

10

- Cost effectiveness: Unlike the multiple-coil design, this solution requires a much simpler control system and fewer components.

15

- Free axial rotation of secondary device: If the secondary device is thin or optionally even cylindrical (see Figure 10), it may be constructed such that it continues to couple well to the flux regardless of its rotation about its longest axis. This may in particular be an advantage if the secondary device is a battery cell fitted within another device, when its axial rotation may be difficult to control.

20

- The magnetic core in the secondary device may be located near other parallel planes of metal within or near the device, for example a copper printed circuit board or aluminium cover. In this case, the performance of embodiments of the present invention is significantly better than that of a conventional core-wound coil because the field lines through a conventional device coil will suffer flux-exclusion if the coil is placed up against the metal plane (because the lines of flux must travel perpendicular to the plane of the coil). Since in embodiments of the present invention the lines of flux travel along the plane of the core, and therefore also of the metal plane, performance is improved. An additional benefit is that the magnetic core in a secondary device of embodiments of the present

25

30

invention can act as a shield between the electromagnetic field generated by the primary unit and any items (e. g. electrical circuits, battery cells) on the other side of the magnetic core.

- Because its permeability is higher than that of air, the magnetic core of the secondary device of embodiments of the present invention acts to concentrate magnetic flux, thus capturing more flux than would otherwise flow through an equivalent cross-section of air. The size of the core's "shape factor" (the equivalent flux-capturing sphere) is determined to a first-order approximation by the longest planar dimension of the core. Therefore if the core of the secondary device of embodiments of the present invention has planar dimensions with a significantly non-square aspect ratio, for example a 4: 1 rectangle instead of a 1 : 1 square, it will capture proportionally more of any flux travelling parallel to the direction of its longest planar dimension. Therefore if used in devices which have a constrained aspect ratio (for example a long thin device such as a headset or pen), a significant increase in performance will be experienced compared with that of a conventional coil of the same area.

The primary unit typically consists of the following components. (See Figure 5)

- 'Power supply : This power supply converts mains voltage into a lower voltage dc supply. This is typically a conventional transformer or a switch-mode power supply ;
- Control unit: The control unit serves the function of maintaining the resonance of the circuit given that the inductance of the means for generating a field changes with the presence of secondary devices. To enable this function, the control unit may be coupled to a sensing unit which feeds back the current status of the circuit. It may also be coupled to a library of capacitors which may be switched in and out as required. If the means for generating a field requires more than one driving circuit, the control unit may also coordinate the parameters such as the phase difference or on/off times of different driving circuits such that the desired effect is achieved. It is also possible for the Q (quality factor) of the system

to be designed to function over a range of inductances such that a need for the above control system is eliminated ;

- 5 • Driving circuit: The driving unit is controlled by the control unit and drives a changing current through the means for generating a field or a component of the means. More than one driving circuit may be present depending on the number of independent components in the means;
- 10 • Means for generating an electromagnetic field: The means uses current supplied from the driving circuits to generate electromagnetic fields of pre-defined shapes and intensities. The exact configuration of the means defines the shape and intensity of the field generated. The means may include magnetic material to act as flux guides and also one or more independently driven components (windings), together forming the charging area. A number of embodiment designs are possible and examples are shown in Figures 6.
- 15 • Sensing unit: The sensing unit retrieves and sends relevant data to the control unit for interpretation.

The secondary device typically consists of the following components, as shown in Figure 5.

- 20 • Magnetic unit: the magnetic unit converts the energy stored in the magnetic field generated by the primary unit back into electrical energy. This is typically implemented by means of a winding wound around a highly permeable magnetic core. The largest dimension of the core typically coincides with the central axis of the winding.
- 25 • Conversion unit: the conversion unit converts the fluctuating current received from the magnetic unit into a form that is useful to the device that it is coupled to. For example, the conversion unit may convert the fluctuating current into an unregulated dc supply by means of a full-wave bridge rectifier and smoothing capacitor. In other cases, the conversion unit may be coupled to a heating element or a battery charger. There is
- 30 also typically a capacitor present either in parallel or in series with the magnetic unit to form a resonant circuit at the operating frequency of the primary unit.

In typical operation, one or more secondary devices are placed on top of the charging surface of the primary unit. The flux flows through the at least one conductor and/or core of the secondary devices present and current is induced. Depending on the configuration of the means for generating a field in the primary unit, the rotational orientation of the secondary device may affect the amount of flux coupled.

The primary unit

The primary unit may exist in many different forms, for example:

- As a flat platform or pad which can sit on top of tables and other flat surfaces;
- Built in to furniture such as desks, tables, counters, chairs, bookcases etc. such that the primary unit may not be visible;
- As part of an enclosure such as a drawer, a box, a glove compartment of a car, a container for power tools;
- As a flat platform or pad which can be attached to a wall and used vertically.

The primary unit may be powered from different sources, for example:

- A mains AC power outlet
- A vehicle lighter socket
- Batteries
- Fuel Cells
- Solar Panel
- Human power

The primary unit may be small enough such that only one secondary device may be accommodated on the charging surface in a single charging area, or may be large enough to accommodate many secondary devices simultaneously, sometimes in different charging areas.

The means for generating a field in the primary unit may be driven at mains frequency (50Hz or 60Hz) or at some higher frequency.

The sensing unit of the primary unit may sense the presence of secondary devices, the number of secondary devices present and even the presence of other magnetic material which is not part of a secondary device. This information

may be used to control the current being delivered to the field generating means of the primary unit.

The primary unit and/or the secondary device may be substantially waterproof or explosion proof.

5 The primary unit and/or the secondary device may be hermetically sealed to standards such as IP66.

10 The primary unit may incorporate visual indicators (for example, but not limited to, light emitting devices, such as light emitting diodes, electrophosphorescent displays, light emitting polymers, or light reflecting devices, such as liquid crystal displays or MITs electronic paper) to indicate the current state of the primary unit, the presence of secondary devices or the number of secondary devices present or any combination of the above.

The means for generating an electromagnetic field

15 The field generating means as referred to in this application includes all configurations of conductors where: The conductors are substantially distributed in the plane and; Substantial areas of the plane exist where there is a non-zero net instantaneous current flow. These are areas on which, given the correct orientation, the secondary devices will couple effectively and receive power. (See Figure 6)

20 • The conductors are capable of generating an electromagnetic field where the field lines subtend an angle of 45° or less or are substantially parallel to a substantial area of the plane.

25 Figures 6 illustrate some possibilities for such a primary conductor. Although most of the configurations are in fact coil windings, it is to be appreciated that the same effect can also be achieved with conductor planes which are not typically considered to be coils (See Figure 6e). These drawings are typical examples and are non- exhaustive. These conductors or coils may be used in combination such that the secondary device can couple effectively in all rotations whilst on the charging area (s) of the primary unit.

30 Magnetic Material

It is possible to use magnetic materials in the primary unit to enhance performance.

- Magnetic material may be placed below one or more charging areas or the entire charging surface such that there is also a low reluctance path on the underside of the conductors for the flux to complete its path. According to theory, an analogy can be drawn between magnetic circuits and electrical circuits. Voltage is analogous to magneto-motive force (mmf), resistance is analogous to reluctance and current is analogous to flux. From this, it can be seen that for a given mmf, flux flow will increase if the reluctance of the path is decreased. By providing magnetic material to the underside of the charging area, the reluctance of the magnetic circuit is essentially decreased. This substantially increases the flux linked by the secondary device and ultimately increases the power transferred. Figure 4d illustrates a sheet of magnetic material placed underneath the charging area and the resulting magnetic circuit.
- Magnetic material may also be placed above the charging surface and/or charging area (s) and below the secondary devices to act as a flux guide. This flux guide performs two functions: Firstly, the reluctance of the whole magnetic circuit is further decreased allowing more flux to flow. Secondly, it provides a low reluctance path along the top surface of the charging area (s) so the flux lines will flow through these flux guides in favour of flowing through the air. Hence this has the effect of containing the field close to the charging surface of the primary unit instead of in the air. The magnetic material used for flux guides may be strategically or deliberately chosen to have different magnetic properties to the magnetic core (where provided) of the secondary device. For example, a material with lower permeability and higher saturation may be chosen. High saturation means that the material can carry more flux and the lower permeability means that when a secondary device is in proximity, a significant amount of flux would then choose to travel through the secondary device in favour of the flux guide. (See Figures 8)
- In some configurations of the primary unit field generating means, there may be conductors present that do not form part of the charging area, such as the component marked 745 in Figure 6a and 6b. In such cases, one

may wish to use magnetic material to shield the effects of these conductors.

- Examples of some materials which may be used include but are not limited to: amorphous metal (metallic glass alloys such as MetGlas), mesh of wires made of magnetic material, steel, ferrite cores, mumetal and permalloy.

The Secondary device

The secondary device may take a variety of shapes and forms. Generally, in order for good flux linkage, a central axis of the conductor (for example, a coil winding) should be substantially non-perpendicular to the charging area (s).

- The secondary device may be in the shape of a flattened winding. (See Figure 7a) The magnetic core inside can consist of sheets of magnetic material such as amorphous metals. This geometry allows the secondary device to be incorporated at the back of electronic devices such as mobile phones, personal digital assistants and laptops without adding bulk to the device.
- The secondary device may be in the shape of a long cylinder. A long cylindrical core could be wound with conductors (See Figure 7b).
- The secondary device may be an object with magnetic material wrapped around it. An example is a standard-sized (AA, AAA, C, D) or other sized/shaped (e. g. dedicated/customised for particular applications) rechargeable battery cell with for example magnetic material wrapped around the cylinder and windings around the cylindrical body.
- The secondary device may be a combination of two or more of the above.

The above embodiments may even be combined with a conventional coil.

The following non-exhaustive list illustrates some examples of objects that can be coupled to a secondary device to receive power. Possibilities are not limited to those described below:

- A mobile communication device, for example a radio, mobile telephone or walkie-talkie ;
- A portable computing device, for example a personal digital assistant or palmtop or laptop computer;

- Portable entertainment devices, for example a music player, games console or toy;
- Personal care items, for example a toothbrush, shaver, hair curler, hair rollers;
- 5 • A portable imaging device, for example a video camcorder or a camera;
- Containers of contents that may require heating, for example coffee mugs, plates, cooking pots, nail-polish and cosmetic containers;
- Consumer devices, for example torches, clocks and fans;
- Power tools, for example cordless drills and screwdrivers;
- 10 • Wireless peripheral devices, for example wireless computer mouse, keyboard and headset;
- Time keeping devices, for example clock, wrist watch, stop watch and alarm clock;
- A battery-pack for insertion into any of the above;
- 15 • A standard-sized battery cell.

In the case of unintelligent secondary devices such as a battery cell, some sophisticated charge-control means may also be necessary to meter inductive power to the cell and to deal with situations where multiple cells in a device have different charge states. Furthermore, it becomes more important for the primary
20 unit to be able to indicate a "charged" condition, since the secondary cell or battery may not be easily visible when located inside another electrical device.

A possible system comprising an inductively rechargeable battery or cell and a primary unit is shown in Figure 10. In addition to the freedom to place the battery 920 freely in (X, Y) and optionally rotate it in rZ, relative to the primary unit
25 910, the battery can also be rotated along its axis rA while continuing to receive power.

When a user inserts a battery into a portable device, it is not easy to ensure that it has any given axial rotation. Therefore, embodiments of the present invention are highly advantageous because they can ensure that the battery can
30 receive power while in any random orientation about rA.

The battery or cell may include a flux concentrating means that may be arranged in a variety of ways:

1. As shown in Figure 11a, a cell 930 may be wrapped in a cylinder of flux-concentrating material 931, around which is wrapped a coil of wire 932.

a. The cylinder may be long or short relative to the length of the cell.

2. As shown in Figure 11b, a cell 930 may have a portion of flux-concentrating material 931 on its surface, around which is wrapped a coil of wire 932.

a. The portion may be conformed to the surface of the cell, or embedded within it.

b. Its area may be large or small relative to the circumference of the cell, and long or short relative to the length of the cell.

3. As shown in Figure 11c, a cell 930 may contain a portion of flux-concentrating material 931 within it, around which is wrapped a coil of wire 932.

a. The portion may be substantially flat, cylindrical, rod-like, or any other shape.

b. Its width may be large or small relative to the diameter of the cell

c. Its length may be large or small relative to the length of the cell

In any of these cases, the flux-concentrator may be a functional part of the battery enclosure (for example, an outer zinc electrode) or the battery itself (for example, an inner electrode).

Issues relating to charging of secondary cells (e. g, AA rechargeable cells in-situ within an appliance include:

- Terminal voltage could be higher than normal.
- Cells in series may behave strangely, particularly in situations where some cells are charged, others not.
- Having to provide enough power to run the device and charge the cell.
- If fast-charging is effected incorrectly, the cells may be damaged.

Accordingly, some sophisticated charge-control means to meter inductive power to the appliance and the cell is advantageously provided. Furthermore, it becomes more important for the primary unit to be able to indicate a "charged" condition, since the secondary cell or battery may not be easily visible when located inside an electrical device.

A cell or battery enabled in this fashion may be charged whilst fitted in another device, by placing the device onto the primary unit, or whilst outside the device by placing the cell or battery directly onto the primary unit.

Batteries enabled in this fashion may be arranged in packs of cells as in
5 typical devices (e. g. end-to-end or side-by-side), allowing a single pack to replace a set of cells.

Alternatively, the secondary device may consist of a flat "adapter" which fits over the batteries in a device, with thin electrodes which force down between the battery electrodes and the device contacts.

10 **Rotating electromagnetic field**

In the coils such as those in Figure 6, 9a and 9b, the secondary devices will generally only couple effectively when the windings are placed substantially parallel to the direction of net current flow in the primary conductor as shown by the arrow 1. In some applications, one might require a primary unit which will
15 transfer power effectively to secondary devices regardless of their rotation as long as:

- the central axis of the secondary conductor is not perpendicular to the plane and;
- the secondary device is in close proximity to the primary unit

20 To enable this, it is possible to have two coils, for example one positioned on top of the other or one woven into or otherwise associated with the other, the second coil capable of generating a net current flow substantially perpendicular to the direction of the first coil at any point in the active area of the primary unit. These two coils may be driven alternately such that each is activated for a certain
25 period of time. Another possibility is to drive the two coils in quadrature such that a rotating magnetic dipole is generated in the plane. This is illustrated in Figure 9. This is also possible with other combinations of coil configurations.

Resonant circuits

It is known in the art to drive coils using parallel or series resonant circuits.
30 In series resonant circuits for example, the impedance of the coil and the capacitor are equal and opposite at resonance, hence the total impedance of the circuit is minimised and a maximum current flows through the primary coil. The

secondary device is typically also tuned to the operating frequency to maximise the induced voltage or current.

In some systems like the electric toothbrush, it is common to have a circuit which is detuned when the secondary device is not present and tuned when the secondary device is in place. The magnetic material present in the secondary device shifts the self-inductance of the primary unit and brings the circuit into resonance. In other systems like passive radio tags, there is no magnetic material in the secondary device and hence does not affect the resonant frequency of the system. These tags are also typically small and used far from the primary unit such that even if magnetic material is present, the inductance of the primary is not significantly changed.

In the proposed system, this is not the case:

- High permeability magnetic material may be present in the secondary device and is used in close proximity to the primary unit;
- One or more secondary devices may be brought in close proximity to the primary unit simultaneously.

This has the effect of shifting the inductance of the primary significantly and also to different levels depending on the number of secondary devices present on the pad. When the inductance of the primary unit is shifted, the capacitance required for the circuit to resonant at a particular frequency also changes. There are three methods for keeping the circuit at resonance:

- By means of a control system to dynamically change the operating frequency ;
- By means of a control system to dynamically change the capacitance such that resonance is achieved at the predefined frequency;
- By means of a low Q system where the system remains in resonance over a range of inductances.

The problem with changing the operating frequency is that the secondary devices are typically configured to resonate at a predefined frequency. If the operating frequency changes, the secondary device would be detuned. To overcome this problem, it is possible to change the capacitance instead of the operating frequency.

The secondary devices can be designed such that each additional device placed in proximity to the primary unit will shift the inductance to a quantised level such that an appropriate capacitor can be switched in to make the circuit resonate at a predetermined frequency. Because of this shift in resonant frequency, the number of devices on the charging surface can be detected and the primary unit can also sense when something is brought near or taken away from the charging surface. If a magnetically permeable object other than a valid secondary device is placed in the vicinity of the charging surface, it is unlikely to shift the system to the predefined quantised level. In such circumstances, the system could automatically detune and reduce the current flowing into the coil.

BRIEF DESCRIPTION OF THE DRAWINGS

For a better understanding of the present invention and to show how it may be carried into effect, reference shall now be made, by way of example only, to the accompanying drawings, in which:

FIGURE 1 shows the magnetic design of typical prior art contact-less power transfer systems which require accurate alignment of the primary unit and secondary device;

FIGURE 2a shows the magnetic design of another typical prior art contact-less power transfer system which involves a large coil in the primary unit;

FIGURE 2b shows the non-uniform field distribution inside the large coil at 5mm distance from the plane of the coil, exhibiting a minimum in the centre;

FIGURE 3 shows a multiple-coil system where each coil is independently driven such that a localised field can be generated.

FIGURE 4a shows an embodiment of the proposed system which demonstrates a substantial departure from prior art with no secondary devices present;

FIGURE 4b shows an embodiment of the proposed system with two secondary devices present ;

FIGURE 4c shows a cross section of the active area of the primary unit and the contour lines of the magnetic flux density generated by the conductors.

FIGURE 4d shows the magnetic circuit for this particular embodiment of the proposed invention;

FIGURE 5 shows a schematic drawing of an embodiment of the primary unit and the secondary device;

5 FIGURE 6a to 6l show some alternative embodiment designs for the field generating means or a component of the field generating means of the primary unit;

FIGURES 7a and 7b show some possible designs for the magnetic unit of the secondary device;

10 FIGURES 8 shows the effect of flux guides (the thickness of the flux guide has been exaggerated for clarity) ;

FIGURE 8a shows that without flux guides, the field tends to fringe into the air directly above the active area;

FIGURE 8b shows the direction of current flow in the conductors in this particular embodiment;

15 FIGURE 8c shows that the flux is contained within the flux guides when magnetic material is placed on top of the charging area;

FIGURE 8d shows a secondary device on top of the primary unit;

FIGURE 8e shows a cross section of the primary unit without any secondary devices;

20 FIGURE 8f shows a cross section of the primary unit with a secondary device on top and demonstrates the effect of using a secondary core with higher permeability than the flux guide.

FIGURE 9a shows a particular coil arrangement with a net instantaneous current flow shown by the direction of the arrow;

25 FIGURE 9b shows a similar coil arrangement to FIGURE 9a except rotated by 90 degrees;

FIGURE 9c shows the charging area of the primary unit if the coil of FIGURE 9a is placed on top of FIGURE 9b. If the coil in FIGURE 9a is driven in quadrature to FIGURE 9b, the effect is a rotating magnetic dipole shown here;

30 FIGURE 10 shows the case where the secondary device has an axial degree of rotation;

FIGURE 11 shows various arrangements of secondary devices with axial degrees of rotation;

FIGURE 12a and FIGURE 12b show another embodiment of the type of coil arrangement shown in FIGURE 9a and FIGURE 9b; and

FIGURE 13 shows a simple embodiment of driving unit electronics.

DESCRIPTION OF PREFERRED EMBODIMENT

5 Referring firstly to Figure 1, there is shown two examples of prior art contact-less power transfer systems which both require accurate alignment of a primary unit and a secondary device. This embodiment is typically used in electric toothbrush or mobile phone chargers.

10 Figure 1a shows a primary magnetic unit 100 and a secondary magnetic unit 200.

On the primary side, a coil 110 is wound around a magnetic core 120 such as ferrite.

15 Similarly, the secondary side consists of a coil 210 wound around another magnetic core 220. In operation, an alternating current flows in to the primary coil 110 and generates lines of flux 1. When a secondary magnetic unit 200 is placed such that it is axially aligned with the primary magnetic unit 100, the flux 1 will couple from the primary into the secondary, inducing a voltage across the secondary coil 210.

20 Figure 1b shows a split transformer. The primary magnetic unit 300 consists of a U-shaped core 320 with a coil 310 wound around it. When alternating current flows into the primary coil 310, changing lines of flux are generated 1. The secondary magnetic unit 400 consists of a second U-shaped core 420 with another coil 410 wound around it. When the secondary magnetic unit 400 is placed on the primary magnetic unit 300 such that the arms of the two
25 U-shaped cores are in alignment, the flux will couple effectively into the core of the secondary 420 and induce voltage across the secondary coil 410.

30 Figure 2a is another embodiment of prior art inductive systems typically used in powering radio frequency passive tags. The primary typically consists of a coil 510 covering a large area. Multiple secondary devices 520 will have voltage induced therein when they are within the area encircled by the primary coil 510. This system does not require the secondary coil 520 to be accurately aligned with the primary coil 510. Figure 2b shows a graph of the magnitude of magnetic flux intensity across the area encircled by the primary coil 510 at 5mm above the

plane of the primary coil. It shows a non-uniform field, which exhibits a minimum 530 at the centre of the primary coil 510.

Figure 3 is another embodiment of a prior art inductive system wherein a multiple coil array is used. The primary magnetic unit 600 consists of an array of
5 coils including coils 611,612, 613. The secondary magnetic unit 700 may consist of a coil 710. When the secondary magnetic unit 700 is in proximity to some coils in the primary magnetic unit 600, the coils 611,612 are activated while other coils such as 613 remain inactive. The activated coils 611,612 generate flux, some of which will couple into the secondary magnetic unit 700.

10 Figure 4 shows an embodiment of the proposed invention. Figure 4a shows a primary coil 710 wound or printed in such a fashion that there is a net instantaneous current flow within the active area 740. For example, if a dc current flows through the primary coil 710, the conductors in the active area 740 would all have current flowing in the same direction. Current flowing through the primary
15 coil 710 generates flux 1. A layer of magnetic material 730 is present beneath the charging area to provide a return path for the flux. Figure 4b shows the same primary magnetic unit as shown in Figure 4a with two secondary devices 800 present. When the secondary devices 800 are placed in the correct orientation on top of the charging area 740 of the primary magnetic unit, the flux 1 will flow
20 through the magnetic core of the secondary devices 800 instead of flowing through the air. The flux 1 flowing through the secondary core would hence induce current in the secondary coil.

Figure 4c shows some contour lines for the flux density of the magnetic field generated by the conductors 711 in the charging area 740 of the primary
25 magnetic unit. There is a layer of magnetic material 730 beneath the conductors to provide a low reluctance return path for the flux.

Figure 4d shows a cross-section of the charging area 740 of the primary magnetic unit. A possible path for the magnetic circuit is shown. The magnetic material 730 provides a low reluctance path for the circuit and also the magnetic
30 core 820 of the secondary magnetic device 800 also provides a low reluctance path. This minimizes the distance the flux has to travel through the air and hence minimizes leakage.

Figure 5 shows a schematic drawing of an embodiment of the whole system of the proposed invention. In this embodiment, the primary unit consists of a power supply 760, a control unit 770, a sensing unit 780 and an electromagnetic unit 700. The power supply 760 converts the mains (or other sources of power) into a dc supply at an appropriate voltage for the system. The control unit 770 controls the driving unit 790 which drives the magnetic unit 700. In this embodiment, the magnetic unit consists of two independently driven components, coil 1 and coil 2, arranged such that the conductors in the charging area of coil 1 would be perpendicular to the conductors in the charging area of coil 2. When the primary unit is activated, the control unit causes a 90-degree phase shift between the alternating current that flows through coil 1 and coil 2. This creates a rotating magnetic dipole on the surface of the primary magnetic unit 700 such that a secondary device is able to receive power regardless of its rotational orientation (See Figure 9). In standby mode where no secondary devices are present, the primary unit is detuned and current flow into the magnetic unit 700 is minimised. When a secondary device is placed on top of the charging area of the primary unit, the inductance of the primary magnetic unit 700 is changed. This brings the primary circuit into resonance and the current flow is maximised. When there are two secondary devices present on the primary unit, the inductance is changed to yet another level and the primary circuit is again detuned.

At this point, the control unit 770 uses feedback from the sensing unit 780 to switch another capacitor into the circuit such that it is tuned again and current flow is maximised. In this embodiment, the secondary devices are of a standard size and a maximum of six standard-sized devices can receive power from the primary unit simultaneously. Due to the standard sizes of the secondary devices, the change in inductance due to the change in secondary devices in proximity is quantized to a number of predefined levels such that only a maximum of 6 capacitances is required to keep the system operating at resonance.

Figures 6a to 6l show a number of different embodiments for the coil component of the primary magnetic unit. These embodiments may be implemented as the only coil component of the primary magnetic unit, in which case the rotation of the secondary device is important to the power transfer.

These embodiments may also be implemented in combination, not excluding embodiments which are not illustrated here. For example, two coils illustrated in Figure 6a may be placed at 90 degrees to each other to form a single magnetic unit. In Figures 6a to 6e, the charging area 740 consists of a series of conductors with net current generally flowing in the same direction. In certain configurations, such as Figure 6c, there is no substantial linkage when the secondary device is placed directly over the centre of the coil and hence power is not transferred. In Figure 6d, there is no substantial linkage when the secondary device is positioned in the gap between the two charging areas 740.

Figure 6f shows a specific coil configuration for the primary unit adapted to generate electromagnetic field lines substantially parallel to a surface of the primary unit within the charging area 740. Two primary windings 710, one on either side of the charging area 740, are formed about opposing arms of a generally rectangular flux guide 750 made out of a magnetic material, the primary windings 710 generating opposing electromagnetic fields. The flux guide 750 contains the electromagnetic fields and creates a magnetic dipole across the charging area 740 in the direction of the arrows indicated on the Figure. When a secondary device is placed in the charging area 740 in a predetermined orientation, a low reluctance path is created and flux flows through the secondary device, causing effective coupling and power transfer. It is to be appreciated that the flux guide 750 need not be continuous, and may in fact be formed as two opposed and non-linked horseshoe components.

Figure 6g shows another possible coil configuration for the primary unit, the coil configuration being adapted to generate electromagnetic field lines substantially parallel to the charging surface of the primary unit within the charging area 740. A primary winding 710 is wound around a magnetic core 750 which may be ferrite or some other suitable material. The charging area 740 includes a series of conductors with instantaneous net current generally flowing in the same direction. The coil configuration of Figure 6g is in fact capable of supporting or defining a charging area 740 on both upper and lower faces as shown in the drawing, and depending on the design of the primary unit, one or both of the charging areas may be made available to secondary devices.

Figure 6h shows a variation of the configuration of Figure 6g. Instead of the primary windings 710 being evenly spaced as in Figure 6g, the windings 710 are not evenly spaced. The spacing and variations therein can be selected or designed so as to provide improved uniformity of performance or field strength levels over the charging area 740.

Figure 6i shows an embodiment in which two primary windings 710 as shown in Figure 6g are located in a mutually orthogonal configuration so as to enable a direction of the field lines to be dynamically switched or rotated to other orientations about the plane of the charging surface.

Figures 6j and 6k show additional two-coil configurations for the primary unit which are not simple geometric shapes with substantially parallel conductors.

In Figure 6j, line 710 indicates one of a set of current-carrying conductors lying in the plane of the charging surface 600. The shape of the main conductor 710 is arbitrary and need not be a regular geometric figure—indeed, conductor 710 may have straight and curved sections and may intersect with itself. One or more subsidiary conductors 719 are arranged alongside and generally parallel (at any given local point) to the main conductor 710 (only two subsidiary conductors 719 are shown here for clarity). Current flow in subsidiary conductors 719 will be in the same direction as in the main conductor 710. The subsidiary conductors 719 may be connected in series or parallel so as to form a single coil arrangement.

In Figure 6k, a set of current-carrying conductors 720 (only some of which are shown for clarity) is arranged in the plane of the charging surface 600. A main conductor 710 is provided as in Figure 6j, and the conductors 720 are each arranged so as to be locally orthogonal to the main conductor 710. The conductors 720 may be connected in series or parallel so as to form a single coil arrangement. If a first sinusoidal current is fed into the conductor 710, and a second sinusoidal current having a 90° phase shift relative to the first current is fed into the coil 720, then by varying the relative proportions and signs of the two currents a direction of a resultant electromagnetic field vector at most points on the charging area 740 will be seen to rotate through 360°.

Figure 6l shows yet another alternative arrangement in which the magnetic core 750 is in the shape of a round disc with a hole in the centre. The first set of

current carrying conductors 710 is arranged in a spiral shape on the surface of the round disc.

5 The second set of conductors 720 is wound in a toroidal format through the centre of the disc and out to the perimeter in a radial fashion. These conductors can be driven in such a way, for example with sinusoidal currents at quadrature, that when a secondary device is placed at any point inside the charging area 740 and rotated about an axis perpendicular to the charging area, no nulls are observed by the secondary device.

10 Figure 7a and 7b are embodiments of the proposed secondary devices. A winding 810 is wound around a magnetic core 820. Two of these may be combined in a single secondary device, at right angles for example, such that the secondary device is able to effectively couple with the primary unit at all rotations. These may also be combined with standard coils, as the ones shown in Figure 2a 520 to eliminate dead spots.

15 Figure 8 shows the effect of flux guides 750 positioned on top of the charging area. The thickness of the material has been exaggerated for the sake of clarity but in reality would be in the order of millimetres thick. The flux guides 750 will minimize leakage and contain the flux at the expense of reducing the amount of flux coupled to the secondary device. In Figure 8a, a primary magnetic unit is shown without flux guides 750. The field will tend to fringe into the air directly above the charging area.

20 With flux guides 750, as shown in Figure 8b to 8f, the flux is contained within the plane of the material and leakage is minimised. In Figure 8e, when there is no secondary device 800 on top, the flux remains in the flux guide 750. In Figure 8f, when a secondary device 800 is present with a relatively more permeable material as the core, part of the flux will flow via the secondary device. The permeability of the flux guide 750 can be chosen such that it is higher than that of typical metals such as steel. When other materials such as steel, which are not part of secondary devices 800, are placed on top, most of the flux will remain in the flux guide 750 instead of travelling through the object. The flux guide 750 may not be a continuous layer of magnetic material but may have small air gaps in them to encourage more flux flow into the secondary device 800 when it is present.

Figure 9 shows an embodiment of a primary unit whereby more than one coil is used. Figure 9a shows a coil 710 with a charging area 740 with current flow parallel to the direction of the arrow 2. Figure 9b shows a similar coil arranged at 90 degrees to the one in Figure 9a. When these two coils are placed on top of each other such that the charging area 740 overlaps, the charging area will look like the illustration in Figure 9c. Such an embodiment would allow the secondary device to be at any rotation on top of the primary unit and couple effectively.

Figure 10 shows an embodiment where the secondary device has an axial degree of rotation, for example where it is, or is embedded within, a battery cell. In this embodiment the secondary device may be constructed such that it couples to the primary flux when in any axial rotation (rA) relative to the primary unit (910), as well as having the same degrees of freedom described above (i. e. translational (X, Y) and optionally rotational perpendicular to the plane of the primary (rZ)).

Figure 11a shows one arrangement where a rechargeable battery cell 930 is wrapped with an optional cylinder of flux-concentrating material 931 which is itself wound with copper wire 932. The cylinder may be long or short relative to the length of the cell.

Figure 11b shows another arrangement where the flux-concentrating material 931 covers only part of the surface of the cell 930, and has copper wire 932 wrapped around it (but not the cell). The material and wire may be conformed to the surface of the cell. Their area may be large or small relative to the circumference of the cell, and long or short relative to the length of the cell.

Figure 11c shows another arrangement where the flux-concentrating material 931 is embedded within the cell 930 and has copper wire 932 wrapped around it. The material may be substantially flat, cylindrical, rod-like, or any other shape, its width may be large or small relative to the diameter of the cell, and its length may be large or small relative to the length of the cell. In any case shown in Figures 10 and 11, any flux-concentrating material may also be a functional part of the battery enclosure (for example, an outer zinc electrode) or the battery itself (for example, an inner electrode).

In any case shown in Figures 10 and 11, the power may be stored in a smaller standard cell (e. g. AAA size) fitted within the larger standard cell enclosure (e. g. AA).

5 Figure 12 shows an embodiment of a primary unit similar to that shown in Figure 9.

10 Figure 12a shows a coil generating a field in a direction horizontal to the page, Figure 12b shows another coil generating a field vertical to the page, and the two coils would be mounted in a substantially coplanar fashion, possibly with one above the other, or even intertwined in some fashion. The wire connections to each coil are shown 940 and the charging area is represented by the arrows 941.

15 Figure 13 shows a simple embodiment of the Driving Unit (790 of Figure 5). In this embodiment there is no Control Unit. The PIC processor 960 generates two 23. 8kHz square waves 90 degrees out of phase with one another. These are amplified by components 961 and driven into two coil components 962, which are the same magnetic units shown in Figure 12a and Figure 12b. Although the driving unit is providing square waves, the high resonant "Q" of the magnetic units shapes this into a sinusoidal waveform.

20 The preferred features of the invention are applicable to all aspects of the invention and may be used in any possible combination.

Throughout the description and claims of this specification, the words "comprise" and "contain" and variations of the words, for example "comprising" and "comprises", mean "including but not limited to", and are not intended to (and do not) exclude other components, integers, moities, additives or steps.

25

THE CLAIMS DEFINING THE INVENTION ARE AS FOLLOWS:

1. A system for transferring power without requiring direct electrical conductive contacts, the system including:

5 a power transfer surface shaped and arranged such that a secondary device can be placed in a working disposition on or in proximity to a power transfer area of the surface to receive power when the system is in use;

a primary unit having a field generating means for generating an electromagnetic field distributed over the power transfer area; and

10 a secondary device separable from the primary unit and having an inductive coupling means which is arranged to couple with the electromagnetic field generated by the primary unit when the secondary device is in its said working disposition, said coupling means being adapted to couple primarily with field lines of the field that are generally parallel to the power transfer surface;

15 wherein the field generating means includes a spiral coil arranged generally parallel to the power transfer surface at or beneath the power transfer area; and

20 when the secondary device is in its said working disposition the inductive coupling means extends over a plurality of radially-spaced portions of the spiral coil, the part of the power transfer area over which the inductive coupling means extends being sufficiently small, relative to the coil, that within said part said coil portions extend generally in parallel with one another in one general direction.

2. A system as claimed in claim 1, wherein the inductive coupling means is arranged to couple with said field when field lines of the field pass through the coupling means in a predetermined coupling direction, and the said coil portions within said part extend generally perpendicularly to said predetermined coupling direction.

3. A system as claimed in claim 1 or 2, wherein said field generating means includes a first coil having a generally flat spiral shape and a second coil wound in

a toroidal form through the centre of the first coil and out to the perimeter thereof in a radial fashion.

4. A system as claimed in claim 3, having driving means for driving said first and second coils alternately.
- 5 5. A system as claimed in claim 3, having driving means for driving said first and second coils in quadrature.
6. A system as claimed in any preceding claim, wherein the or each said coil includes conductive tracks formed on a planar surface.
7. A system as claimed in any preceding claim, wherein said primary unit
10 further includes a magnetic core across which the or each said coil extends.
8. A system as claimed in any preceding claim, wherein said inductive coupling means includes at least one electrical conductor.
9. A system as claimed in any preceding claim, wherein said inductive coupling means includes a coil.
- 15 10. A system as claimed in claim 9, wherein said coil of said inductive coupling means is arranged such that a central axis thereof is substantially non-perpendicular to the power transfer surface when the secondary device is in its said working disposition.
11. A system as claimed in claim 10, wherein said central axis is substantially
20 parallel to said power transfer surface when the secondary device is in its said working disposition.
12. A system as claimed in any preceding claim, wherein said inductive coupling means includes a flux-concentrating core.

13. A system as claimed in claim 12, wherein said core of said inductive coupling means is arranged such that a longitudinal axis thereof is substantially non-perpendicular to the power transfer surface when the secondary device is in its said working disposition.

5 14. A system as claimed in claim 13, wherein said longitudinal axis is substantially parallel to the power transfer surface when the secondary device is in its said working disposition.

10 15. A system as claimed in any preceding claim, wherein said secondary device is carried in or by an object requiring power and can receive power from the primary unit when said object is placed on or in proximity to said power transfer surface so that the carried secondary device has its said working disposition.

15 16. A system as claimed in claim 15, wherein said object includes at least one battery or cell and said secondary device is in the form of a flat adapter which is fitted over said battery or cell and which has thin electrodes insertable between terminals of the battery or cell and terminals of the object.

17. A system as claimed in any preceding claim, wherein said secondary device is carried in or by a rechargeable battery or cell fitted, or adapted to be fitted, into an object requiring power.

20 18. A system as claimed in claim 17, wherein, when said battery or cell is fitted into said object and said object is placed on or in proximity to said power transfer surface so that said secondary device has its said working disposition, the battery or cell can be recharged without removing it from said object.

25 19. A system as claimed in claim 17 or 18, wherein said rechargeable battery or cell is an industry-standard-sized battery or cell.

20. A system as claimed in claim 17 or 18, wherein said rechargeable battery or cell is of a size and/or shape dedicated or customised for a particular application.
- 5 21. A system as claimed in claim 17, 18, 19 or 20, wherein said rechargeable battery or cell further includes an energy-storage means and a power conversion means for converting power received inductively by the secondary device into a form suitable for delivery to outside said battery or cell through external electrical connections thereof, or into a form suitable for recharging the energy-storage means, or into both said forms.
- 10 22. A system as claimed in claim 21 when read as appended to claim 18, wherein said rechargeable battery or cell has charge-control means operable, when the secondary device is receiving power inductively, to meter the supply of inductively-received power to the external electrical connections and to the energy-storage means.
- 15 23. A system as claimed in any of claims 17 to 22, wherein the rechargeable battery or cell further includes a flux concentrating means, and said at least one conductor is wound about said flux concentrating means.
24. A system as claimed in claim 23, wherein the flux concentrating means is at least partially wrapped around a central part of the battery or cell.
- 20 25. A system as claimed in any of claims 15 to 24, wherein said object is portable.
26. A system as claimed in any of claims 15 to 25, wherein said object is a portable electrical or electronic device.
- 25 27. A system as claimed in any of claims 15 to 26, wherein said object is a mobile communication device.

28. A system as claimed in any of claims 15 to 27, wherein said power transfer area is large enough to accommodate simultaneously two or more such secondary devices carried in or by different respective such objects.
29. A system as claimed in any of claims 15 to 28, wherein said primary unit is
5 part of an enclosure for said object.
30. A system as claimed in any preceding claim, wherein said primary unit is incorporated in an item of furniture having a surface which provides said power transfer surface.
31. A system as claimed in any preceding claim, wherein a height of said field
10 generating means, measured in a direction substantially perpendicular to the power transfer surface, is less than either a width or a length of said power transfer area on said power transfer surface.
32. A system as claimed in claim 31, wherein said height is no more than half of the length or half of the width of the power transfer area.
- 15 33. A system as claimed in claim 31, wherein said height is no more than 1/5 of the length or 1/5 of the width of the power transfer area.
34. A system as claimed in any preceding claim, wherein the primary unit is in the form of a flat platform having a main face which provides said power transfer surface.
- 20 35. A system as claimed in any preceding claim, wherein said power transfer surface is substantially planar.
36. A system as claimed in any of claims 1 to 34, wherein said power transfer surface is curved.
37. A system as claimed in any preceding claim, wherein said field generating
25 means does not project beyond the power transfer surface.

38. A system as claimed in any preceding claim, wherein the primary unit further includes driving means for applying electrical drive signals to said field generating means such that, in at least one said part of the power transfer area, said field lines, when resolved onto the power transfer area, change in direction over time.

39. A system as claimed in claim 38, wherein said driving means are operable to apply electrical drive signals to said field generating means such that said field lines are switched between two or more different predetermined directions over time.

40. A system as claimed in claim 38, wherein the driving means are operable to apply electrical drive signals to said field generating means such that the field line directions are rotated through an angle over time.

41. A system as claimed in claim 38, wherein said driving means are operable to apply electrical drive signals to said field generating means such that the field line directions are rotated through a complete circle over time.

42. A portable electrical or electronic device adapted to receive power inductively from a primary unit, the device including:

a cover element having a substantially planar portion with inner and outer surfaces, the device being adapted to be placed with said outer surface on or in proximity to such a primary unit when receiving power therefrom; and

a power-receiving element in the form of a thin sheet, including a coil arranged in close proximity to said inner surface of said cover element and having a central axis extending generally parallel to a plane of said planar portion, for receiving power inductively from the primary unit when the device is so placed on or in proximity to the primary unit.

43. An adapter assembly, for a portable electrical or electronic device which includes a cover element having a substantially planar portion with inner and outer surfaces and which is fitted with, or is adapted to be fitted with, one or more

batteries such that said one or more batteries are located adjacent to said inner surface of said planar portion, the assembly including:

5 a power-receiving element, in the form of a thin sheet and having a coil, adapted to fit in a space between said inner surface of said planar portion and said one or more batteries such that said coil is arranged in close proximity to said inner surface of said planar portion and has a central axis extending generally parallel to a plane of said planar portion, said power-receiving element being adapted to receive power inductively from a primary unit when the device is placed with said outer surface on or in proximity to the primary unit; and

10 thin electrodes, connected to said power-receiving element and adapted for insertion between terminals of said one or more batteries and battery terminals of the device when the power-receiving element is fitted in said space, for supplying power received inductively by said power-receiving element to said device.

15 44. A portable electrical or electronic device or an adapter assembly, as the case may be, as claimed in claim 42 or 43, wherein said thin sheet is substantially flat.

45. A portable electrical or electronic device or an adapter assembly, as the case may be, as claimed in claim 42 or 43, wherein said thin sheet is curved.

20 46. A portable electrical or electronic device or an adapter assembly, as the case may be, as claimed in any preceding claim, wherein said power-receiving element further includes a core of magnetic material, said coil being wound about said core and said core having a longitudinal axis which extends generally parallel to said plane.

25 47. A portable electrical or electronic device or an adapter assembly, as the case may be, as claimed in claim 46, wherein said core is in the form of a thin sheet extending generally parallel to said plane.

48. A portable electrical or electronic device or an adapter assembly, as the case may be, as claimed in claim 46 or 47, wherein a thickness of said core, measured in a direction perpendicular to said plane, is 2 mm or less.
49. A portable electrical or electronic device or an adapter assembly, as the
5 case may be, as claimed in claim 48, wherein said core thickness is 1 mm or less.
50. A portable electrical or electronic device or an adapter assembly, as the case may be, as claimed in any of claims 46 to 49, wherein the largest dimension of said core is in the direction of said central axis of said coil.
51. A portable electrical or electronic device or an adapter assembly, as the
10 case may be, as claimed in any of claims 46 to 50, wherein said core has high magnetic permeability.
52. A portable electrical or electronic device or an adapter assembly, as the case may be, as claimed in any of claims 46 to 51, wherein said core is made of amorphous magnetically permeable material.
- 15 53. A portable electrical or electronic device or an adapter assembly, as the case may be, as claimed in claim 52, wherein said amorphous magnetically permeable material is in a substantially non-annealed state.
54. A portable electrical or electronic device or an adapter assembly, as the
20 case may be, as claimed in claim 53, wherein said amorphous magnetically permeable material is in a substantially as-cast state.
55. A portable electrical or electronic device or an adapter assembly, as the case may be, as claimed in claim 53, 54 or 55, wherein said amorphous magnetically permeable material is in the form of a flexible ribbon.
- 25 56. A portable electrical or electronic device or an adapter assembly, as the case may be, as claimed in claim 55, wherein said ribbon includes one or more layers of amorphous magnetically permeable material.

57. A portable electrical or electronic device or an adapter assembly, as the case may be, as claimed in any of claims 46 to 56, wherein said core has a shape parallel to said plane that is generally rectangular and significantly non-square.

5 58. A portable electrical or electronic device or an adapter assembly, as the case may be, as claimed in any of claims 42 to 57, wherein the portable electrical or electronic device is a long thin device.

10 59. A portable electrical or electronic device or an adapter assembly, as the case may be, as claimed in any of claims 42 to 58, wherein a thickness of said power-receiving element, measured in a direction perpendicular to said plane, is small relative to the dimensions of the power-receiving element parallel to said plane.

15 60. A portable electrical or electronic device or an adapter assembly, as the case may be, as claimed in any of claims 42 to 59, wherein said power-receiving element has two such coils, the respective central axes of said two coils extending in different directions generally parallel to said plane.

61. A portable electrical or electronic device or an adapter assembly, as the case may be, as claimed in claim 60, wherein the respective central axes of said two coils extend in mutually orthogonal directions generally parallel to said plane.

20 62. A portable electrical or electronic device or an adapter assembly, as the case may be, as claimed in any of claims 42 to 61, wherein said portable electrical or electronic device has a metal plane extending generally parallel to said plane of said planar portion of said cover element.

25 63. A portable electrical or electronic device or an adapter assembly, as the case may be, as claimed in any of claims 42 to 62, wherein the portable electrical or electronic device has a printed circuit board extending generally parallel to a plane of said planar portion of said cover element.

64. A portable electrical or electronic device or an adapter assembly, as the case may be, as claimed in any of claims 42 to 63, wherein said planar portion of said cover element includes metal.

5 65. A portable electrical or electronic device or an adapter assembly, as the case may be, as claimed in any of claims 46 to 57, wherein said core is located between said cover element and components of the device susceptible to electromagnetic fields so that the core can serve to reduce the effects on such components of an electromagnetic field generated by the primary unit .

10 66. A portable electrical or electronic device or an adapter assembly, as the case may be, as claimed in any of claims 42 to 65, further including conversion means connected to the or each said coil for converting a current induced in the or each said coil into a form suitable for delivery to parts of the device requiring power.

15 67. A rechargeable battery adapted to receive power inductively from an external unit when fitted into a battery holder in a portable electrical or electronic device, the external unit having a field generating surface and a field generator which generates an electromagnetic field at or over the field generating surface, and the device being adapted to be placed in an intended power-receiving disposition on or in proximity to said field generating surface of the external unit
20 when the battery is to be recharged, and the device including a housing including a predetermined portion having an external surface which faces said field generating surface when said device is placed in its said power-receiving disposition, the battery including:

25 a magnetic core component carried in or by said battery in such a way that when the battery is retained by said battery holder and said device is in its said power-receiving disposition the core component is in proximity to an internal surface of said predetermined portion and couples with the field, the magnetic core component including a thin sheet of magnetic material and also including a coil wound around said sheet for receiving power inductively from the
30 external unit, the sheet and the coil being arranged so that a longitudinal axis of

the sheet and a central axis of the coil each extend generally parallel to said field generating surface when the battery is retained in said battery holder and the device is in its said power-receiving disposition.

5 68. A rechargeable battery as claimed in claim 67, wherein said thin sheet is substantially flat.

69. A rechargeable battery as claimed in claim 67, wherein said thin sheet is curved.

10 70. A rechargeable battery as claimed in any of claims 67 to 69, wherein said coil extends in its axial direction over a distance that is large compared to a thickness of said magnetic core component.

71. A rechargeable battery as claimed in any of claims 67 to 70, wherein said magnetic material is amorphous magnetically permeable material.

15 72. A rechargeable battery as claimed in any of claims 67 to 71, wherein:
the battery holder is adapted to retain the battery in the device with its longitudinal axis extending generally parallel to said field generating surface when the device is in its said power-receiving disposition; and

20 the sheet and the coil are arranged so that said longitudinal axis of the sheet and said central axis each extend generally parallel to said field generating surface when the battery is so retained in said battery holder and the device is in its said power-receiving disposition.

25 73. A rechargeable battery as claimed in claim 67, wherein the magnetic core component is at least partially wrapped around an axis of the battery such that it couples with an electromagnetic field generated by said external unit in any rotation about the axis when the device is in its said power-receiving disposition and the battery is retained in said battery holder.

74. A rechargeable battery, adapted to receive power inductively from a primary unit when fitted into a space in a portable electrical or electronic device, the device including a cover element having a substantially planar portion with inner and outer surfaces and being adapted to be placed with said outer surface
5 on or in proximity to such a primary unit when the battery is to be recharged, and the device being adapted to retain the battery in the space with its longitudinal axis extending generally parallel to a plane of said planar portion, the battery including:

10 a power-receiving element including a coil which is in close proximity to said inner surface of said cover element when the cell is so retained in said space and which has a central axis that extends generally parallel to a plane of said planar portion, for receiving power inductively from the primary unit when the device is so placed on or in proximity to the primary unit; and

15 a rechargeable energy-storing element connected to the power-receiving element for storing the power received inductively by the power-receiving element;

wherein said power-receiving element is in the form of a thin sheet.

75. A rechargeable battery as claimed in claim 74, wherein said thin sheet is substantially flat.

20 76. A rechargeable battery as claimed in claim 74, wherein said thin sheet is curved.

77. A rechargeable battery as claimed in any of claims 74 to 76, wherein said power-receiving element further includes a core of magnetic material, said core having a longitudinal axis which extends generally parallel to said plane.

25 78. A rechargeable battery as claimed in claim 77, wherein said coil is wound about said core.

79. A rechargeable battery as claimed in claim 77 or 78, wherein said core is in the form of a thin sheet extending generally parallel to said plane.

80. A rechargeable battery—as claimed in any of claims 77 to 79, wherein the largest dimension of said core is in the direction of said central axis of said coil.
81. A rechargeable battery as claimed in any of claims 77 to 80, wherein said core has a significantly non-square shape parallel to said plane.
- 5 82. A rechargeable battery as claimed in any of claims 77 or 81, wherein said coil extends in its axial direction over a distance that is large compared to a thickness of said power-receiving element.
83. A rechargeable battery as claimed in any of claims 77 to 82, wherein said core is made of amorphous magnetically permeable material.
- 10 84. A rechargeable battery as claimed in any of claims 74 to 83, wherein said power-receiving element has two such coils, the respective central axes of said two coils extending in mutually orthogonal directions generally parallel to said plane.
85. A rechargeable battery as claimed in any of claims 74 to 84, wherein said
15 portable electrical or electronic device has a metal plane extending generally parallel to said plane of said planar portion of said cover element.
86. A rechargeable battery as claimed in any of claims 74 to 85, wherein the portable electrical or electronic device has a printed circuit board extending generally parallel to a plane of said planar portion of said cover element.
- 20 87. A rechargeable battery as claimed in any of claims 74 to 86, wherein said planar portion of said cover element includes metal.
88. A rechargeable battery as claimed in claim 77, wherein, when the battery is retained in said space, said core is located between said cover element and components of the device susceptible to electromagnetic fields so that the core
25 can serve to reduce the effects on such components of an electromagnetic field generated by the primary unit.

89. A rechargeable battery as claimed in any of claims 74 to 88, wherein said rechargeable battery further includes a power conversion unit which converts power received inductively by the power-receiving element into a form suitable for delivery to outside said battery through external electrical connections thereof, or
5 into a form suitable for recharging the energy-storing element, or into both said forms.

90. A rechargeable battery as claimed in claim 89, wherein said rechargeable battery has a charge-control unit operable, when the power-receiving element is receiving power inductively, to meter the supply of inductively-received power to
10 the external electrical connections and to the energy-storing element.

91. A rechargeable battery as claimed in any of claims 74 to 90, having an enclosure and external electrical connections similar in dimensions to an industry-standard battery.

92. A rechargeable battery adapted to receive power inductively from a
15 primary unit when fitted into a space in a portable electrical or electronic device, the device including a cover element having a substantially planar portion with inner and outer surfaces and being adapted to be placed with said outer surface on or in proximity to such a primary unit when the battery is to be recharged, and the device being adapted to retain the battery in the space with its longitudinal
20 axis extending generally parallel to a plane of said planar portion, the battery including:

a power-receiving element including a coil which is in close proximity to said inner surface of said cover element when the cell is so retained in said space and which has a central axis that extends generally parallel to a plane of said
25 planar portion, for receiving power inductively from the primary unit when the device is so placed on or in proximity to the primary unit; and

a rechargeable energy-storing element connected to the power-receiving element for storing the power received inductively by the power-receiving element;

wherein a thickness of said power-receiving element, measured in a direction perpendicular to said plane, is small relative to the dimensions of the power-receiving element parallel to said plane.

5 93. A rechargeable battery, adapted to receive power inductively from a primary unit, the battery including:

a generally cylindrical body having a central axis;

10 a power-receiving element, including a coil having a central axis extending generally in parallel with said central axis of said body, for receiving power inductively from the primary unit when the battery is placed on or in proximity to a power transfer surface of the primary unit with said central axis of said body lying across the surface; and

a rechargeable energy-storing element connected to said power-receiving element for storing the power received inductively by the power-receiving element;

15 wherein said power-receiving element is in the form of a thin sheet.

94. A rechargeable battery as claimed in claim 93, wherein said thin sheet is curved.

20 95. A rechargeable battery as claimed in claim 93 or 94, wherein said thin sheet is wrapped circumferentially around said body or around another generally cylindrical component of the battery.

96. A rechargeable battery as claimed in any of claims 93 to 95, wherein said power-receiving element further includes a core of magnetic material, said core having a longitudinal axis which extends generally parallel to said central axis of said body.

25 97. A rechargeable battery as claimed in claim 96, wherein said coil is wound about said core.

98. A rechargeable battery as claimed in claim 96 or 97, wherein said coil extends in its axial direction over a distance that is large compared to a thickness of said power-receiving element.

5 99. A rechargeable battery as claimed in claim 96, 97 or 98, wherein said core is made of amorphous magnetically permeable material.

10 100. A rechargeable battery as claimed in any of claims 93 to 99, wherein said rechargeable battery further includes a power conversion unit which converts power received inductively by the power-receiving element into a form suitable for delivery to outside said battery through external electrical connections thereof, or into a form suitable for recharging the energy-storing element, or into both said forms.

15 101. A rechargeable battery as claimed in claim 100, wherein said rechargeable battery has a charge-control unit operable, when the power-receiving element is receiving power inductively, to meter the supply of inductively-received power to the external electrical connections and to the energy-storing element.

102. A rechargeable battery as claimed in any of claims 93 to 101 having an enclosure and external electrical connections similar in dimensions to an industry-standard battery.

20 **AMWAY (EUROPE) LIMITED**

WATERMARK PATENT & TRADE MARK ATTORNEYS

25 P24805AU01

CLAIMS:

1. A system for transferring power without requiring direct electrical conductive contacts, the system comprising:

5

i) a primary unit including a substantially laminar charging surface and at least one means for generating an electromagnetic field, the means being distributed in two dimensions across a predetermined area in or parallel to the charging surface so as to define at least one charging area of the charging surface that is substantially
10 coextensive with the predetermined area, the charging area having a width and a length on the charging surface, wherein the means is configured such that, when a predetermined current is supplied thereto and the primary unit is effectively in electromagnetic isolation, an electromagnetic field generated by the means has electromagnetic field lines that, when averaged over any quarter length part of the
15 charging area measured parallel to a direction of the field lines, subtend an angle of 45° or less to the charging surface in proximity thereto and are distributed in two dimensions thereover, and wherein the means has a height measured substantially perpendicular to the charging area that is less than either of the width or the length of the charging area; and

20

ii) at least one secondary device including at least one electrical conductor;

wherein, when the at least one secondary device is placed on or in proximity to a charging area of the primary unit, the electromagnetic field lines couple with the at
25 least one conductor of the at least one secondary device and induce a current to flow therein.

2. A system as claimed in claim 1, wherein the means comprises at least one electrical conductor that is distributed in two dimensions in or substantially parallel
30 to the charging surface.

3. A system as claimed in claim 1, wherein the means comprises at least one electrical conductor wound onto at least part of a magnetically permeable former that is distributed in two dimensions in or substantially parallel to the charging surface.
- 5 4. A system as claimed in any preceding claim, wherein the means includes a plurality of conductors configured so as to cause a directional component of the electromagnetic field lines, resolved onto the charging area, to be changed over time.
- 10 5. A system as claimed in claim 4, wherein the plurality of conductors is configured so as to cause the resolved directional component of the field lines to be switched between at least two different directions.
- 15 6. A system as claimed in claim 4, wherein the plurality of conductors is configured so as to cause the resolved directional component of the field lines to be moved through an angle.
- 20 7. A system as claimed in claim 6, wherein the plurality of conductors is configured so as to cause the resolved directional component of the field lines to be rotated.
- 25 8. A system as claimed in any preceding claim, wherein the field lines over a given charging area are substantially parallel to each other when projected onto the charging area.
- 30 9. A system as claimed in any preceding claim, wherein an instantaneous net flow of current in a given one of the at least one means when energised is in substantially one direction.
10. A system as claimed in any preceding claim, wherein the means does not project beyond the charging surface.

11. A system as claimed in any preceding claim, wherein the at least one charging area is provided with a substrate of a magnetic material.
12. A system as claimed in any preceding claim, wherein the primary unit
5 includes at least one selectively operable capacitor configured such that a capacitance of a circuit including the at least one means for generating an electromagnetic field and the at least one capacitor may be changed in response to a detected presence of one or more secondary devices.
- 10 13. A system as claimed in any preceding claim, wherein the at least one charging area is provided with a flux guide having a relative permeability less than that of the core of the at least one secondary device.
14. A system as claimed in any preceding claim, wherein the primary unit
15 includes a power supply.
15. A system as claimed in any preceding claim, wherein the at least one conductor in the secondary device is wound about a core that serves to concentrate flux therein.
20
16. A system as claimed in claim 15, wherein the core is a magnetically permeable material.
17. A system as claimed in claim 16, wherein the core is an amorphous magnetic
25 material.
18. A system as claimed in claim 17, wherein the core is a substantially non-annealed amorphous magnetic material.
- 30 19. A system as claimed in any one of claims 15 to 18, wherein the core is formed as a flexible ribbon.

20. A system as claimed in any preceding claim, wherein the secondary device comprises an inductively rechargeable battery or cell.
21. A system as claimed in claim 20, wherein the inductively rechargeable battery or cell includes at least one conductor wound about a flux concentrating means.
22. A system as claimed in any preceding claim, wherein at least one of the at least one means is configured to generate an electromagnetic field over more than one charging area.
23. A system as claimed in any one of claims 1 to 21, wherein a plurality of means is configured to generate an electromagnetic field over a single charging area.
24. A system as claimed in any preceding claim, wherein the means has a height that is no more than half of the length or half of the width of the charging area.
25. A system as claimed in any preceding claim, wherein the means has a height that is no more than 1/5 of the length or 1/5 of the width of the charging area.
26. A primary unit for transferring power without requiring direct electrical conductive contacts, the primary unit including a substantially laminar charging surface and at least one means for generating an electromagnetic field, the means being distributed in two dimensions across a predetermined area in or parallel to the charging surface so as to define at least one charging area of the charging surface that is substantially coextensive with the predetermined area, the charging area having a width and a length on the charging surface, wherein the means is configured such that, when a predetermined current is supplied thereto and the primary unit is effectively in electromagnetic isolation, an electromagnetic field generated by the means has electromagnetic field lines that, when averaged over any quarter length part of the charging area measured parallel to a direction of the field lines, subtend an angle of 45° or less to the charging surface in proximity thereto and are distributed in

two dimensions thereover, and wherein the means has a height measured substantially perpendicular to the charging area that is less than either of the width or the length of the charging area.

5 27. A primary unit as claimed in claim 26, wherein the means comprises at least one electrical conductor that is distributed in two dimensions in or substantially parallel to the charging surface.

10 28. A primary unit as claimed in claim 26, wherein the means comprises at least one electrical conductor wound onto at least part of a magnetically permeable former that is distributed in two dimensions in or substantially parallel to the charging surface.

15 29. A primary unit as claimed in any one of claims 26 to 28, wherein the means includes a plurality of conductors configured so as to cause a directional component of the electromagnetic field lines, resolved onto the charging area, to be changed over time.

20 30. A primary unit as claimed in claim 29, wherein the plurality of conductors is configured so as to cause the resolved directional component of the field lines to be switched between at least two different directions.

25 31. A primary unit as claimed in claim 29, wherein the plurality of conductors is configured so as to cause the resolved directional component of the field lines to be moved through an angle.

30 32. A primary unit as claimed in claim 31, wherein the plurality of conductors is configured so as to cause the resolved directional component of the field lines to be rotated.

2008255158 05 Dec 2008

WO 03/096512

57

PCT/GB03/02030

33. A primary unit as claimed in any one of claims 26 to 32, wherein the field lines over a given charging area are substantially parallel to each other when projected onto the charging area.
- 5 34. A primary unit as claimed in any one of claims 26 to 33, wherein an instantaneous net flow of current in a given one of the at least one means when energised is in substantially one direction.
- 10 35. A primary unit as claimed in any one of claims 26 to 34, wherein the means does not project beyond the charging surface.
36. A primary unit as claimed in any one of claims 26 to 35, wherein the at least one area is provided with a substrate of a magnetic material.
- 15 37. A primary unit as claimed in any one of claims 26 to 36, including at least one selectively operable capacitor configured such that a capacitance of a circuit including the at least one means for generating an electromagnetic field and the at least one capacitor may be changed in response to a detected presence of one or more secondary devices.
- 20 38. A primary unit as claimed in any one of claims 26 to 37, wherein the primary unit includes a power supply.
- 25 39. A primary unit as claimed in any one of claims 26 to 38, wherein the at least one area is provided with a flux guide having a relative permeability less than that of any core that may be provided in the at least one secondary device.
- 30 40. A primary unit as claimed in any one of claims 26 to 39, wherein at least one of the at least one means is configured to generate an electromagnetic field over more than one charging area.

45

41. A primary unit as claimed in any one of claims 26 to 39, wherein a plurality of means is configured to generate an electromagnetic field over a single charging area.
- 5 42. A primary unit as claimed in any one of claims 26 to 41, wherein the means has a height that is no more than half of the length or half of the width of the charging area.
- 10 43. A primary unit as claimed in any one of claims 26 to 42, wherein the means has a height that is no more than 1/5 of the length or 1/5 of the width of the charging area.
- 15 44. A method of transferring power in a non-conductive manner from a primary unit to a secondary device, the primary unit including a substantially laminar charging surface and at least one means for generating an electromagnetic field, the means being distributed in two dimensions across a predetermined area in or parallel to the charging surface so as to define at least one charging area of the charging surface that is substantially coextensive with the predetermined area, the charging area having a width and a length on the charging surface, the means having a height
- 20 measured substantially perpendicular to the charging area that is less than either of the width or the length of the charging area, and the secondary device having at least one electrical conductor; wherein:
- 25 i) an electromagnetic field, generated by the means when energised with a predetermined current and measured when the primary unit is effectively in electromagnetic isolation, has electromagnetic field lines that, when averaged over any quarter length part of the charging area measured parallel to a direction of the field lines, subtend an angle of 45° or less to the charging surface in proximity thereto and are distributed in two dimensions over the at least one charging area
- 30 when averaged thereover; and

ii) the electromagnetic field links with the conductor of the secondary device when this is placed on or in proximity to the charging area.

5 45. A method according to claim 44, wherein the means comprises at least one electrical conductor that is distributed in two dimensions in or substantially parallel to the charging surface.

10 46. A method according to claim 44, wherein the means comprises at least one electrical conductor wound onto at least part of a magnetically permeable former that is distributed in two dimensions in or substantially parallel to the charging surface.

15 47. A method according to any one of claims 44 to 46, wherein a directional component of the electromagnetic field lines, resolved onto the charging area, is changed over time.

48. A method according to claim 47, wherein the resolved directional component of the field lines is switched between at least two different directions.

20 49. A method according to claim 47, wherein the resolved directional component of the field lines is moved through an angle.

50. A method according to claim 49, wherein the resolved directional component of the field lines is rotated.

25 51. A method according to any one of claims 44 to 50, wherein the field lines over a given charging area are substantially parallel to each other when projected onto the charging area.

30 52. A method according to any one of claims 44 to 51, wherein an instantaneous net flow of current in a given one of the at least one means when energised is in substantially one direction.

A7

53. A method according to any one of claims 44 to 52, wherein the at least one charging area is provided with a substrate of a magnetic material and wherein the magnetic material completes a magnetic circuit.
- 5 54. A method according to any one of claims 44 to 53, wherein the primary unit includes at least one selectively operable capacitor that is switched in or out such that a capacitance of a circuit including the at least one primary unit means for generating an electromagnetic field and the at least one capacitor may be changed in response to a detected presence of one or more secondary devices.
- 10 55. A method according to any one of claims 44 to 54, wherein the charging surface, at least within the at least one charging area, is provided with a flux guide having a relative permeability less than that of any core that may be provided in the at least one secondary device.
- 15 56. A secondary device for use with the system, primary unit or method of any one of the preceding claims, the secondary device including at least one electrical conductor and having a substantially laminar form factor.
- 20 57. A secondary device as claimed in claim 56, wherein the at least one electrical conductor is wound about a core that serves to concentrate flux therein.
58. A secondary device as claimed in claim 57, wherein the core is a magnetically permeable material.
- 25 59. A secondary device as claimed in claim 58, wherein the core is an amorphous magnetic material.
- 30 60. A secondary device as claimed in claim 59, wherein the core is a substantially non-annealed amorphous magnetic material.

2008255158 05 Dec 2008

WO 03/096512

61

PCT/GB03/02030
PL 17/08 2003 7 0 v 1.1

61. A secondary device as claimed in any one of claims 57 to 60, wherein the core is formed as a flexible ribbon.
62. A secondary device as claimed in any one of claims 56 to 61, wherein the secondary device comprises an inductively rechargeable battery or cell.
63. A secondary device as claimed in claim 57 or any claim depending therefrom, having a core thickness of 2mm or less.
64. A secondary device as claimed in claim 63, having a core thickness of 1mm or less.
65. A secondary device as claimed in any one of claims 56 to 64, wherein the secondary device has a primary axis and couples with the electromagnetic field when located on or in proximity to the charging area in any rotation about its axis.
66. A secondary device as claimed in claim 65 depending from claim 62, wherein the core is at least partially wrapped around a central part of the battery or cell.
67. A system as claimed in any one of claims 1 to 25, wherein the primary unit includes a pair of conductors having adjacent coplanar windings which have mutually substantially parallel linear sections arranged so as to produce a substantially uniform electromagnetic field extending generally parallel to the plane of the windings but substantially at right angles to the parallel sections.
68. A system as claimed in claim 67, wherein the windings are formed in a generally spiral shape, comprising a series of turns having substantially parallel straight sections.
69. A system as claimed in claim 67 or 68, wherein the primary unit includes first and second pairs of conductors which are superimposed in substantially parallel planes with the substantially parallel linear sections of the first pair arranged

49

generally at right angles to the substantially parallel linear sections of the second pair, and further comprising a driving circuit which is arranged to drive them in such a way as to generate a resultant field which rotates in a plane substantially parallel to the planes of the windings.

5

70. A primary unit as claimed in any one of claims 26 to 43, including a pair of conductors having adjacent coplanar windings which have mutually substantially parallel linear sections arranged so as to produce a substantially uniform electromagnetic field extending generally parallel to the plane of the windings but substantially at right angles to the parallel sections.

10

71. A primary unit as claimed in claim 70, wherein the windings are formed in a generally spiral shape, comprising a series of turns having substantially parallel straight sections.

15

72. A primary unit as claimed in claim 70 or 71, including first and second pairs of conductors which are superimposed in substantially parallel planes with the substantially parallel linear sections of the first pair arranged generally at right angles to the substantially parallel linear sections of the second pair, and further comprising a driving circuit which is arranged to drive them in such a way as to generate a resultant field which rotates in a plane substantially parallel to the planes of the windings.

20

73. A system for transferring power, substantially as hereinbefore described with reference to Figures 4 to 13 of the accompanying drawings.

25

74. A primary unit for transferring power, substantially as hereinbefore described with reference to Figures 4 to 13 of the accompanying drawings.

30

75. A method of transferring power, substantially as hereinbefore described with reference to Figures 4 to 13 of the accompanying drawings.

2008255158 05 Dec 2008

WO 03/096512

63

PCT/GB03/02030

76. A secondary device for receiving power, substantially as hereinbefore described with reference to Figures 4 to 13 of the accompanying drawings.

51

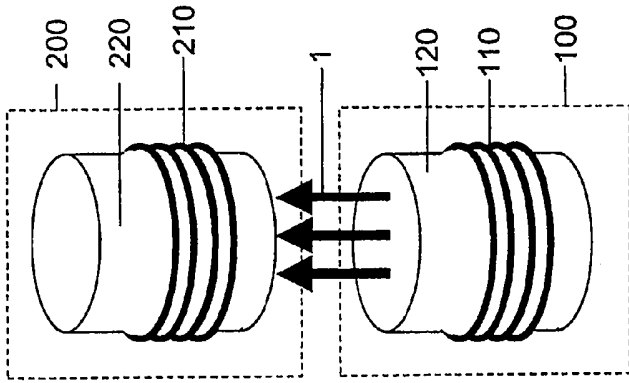

Figure 1a
(Prior Art)

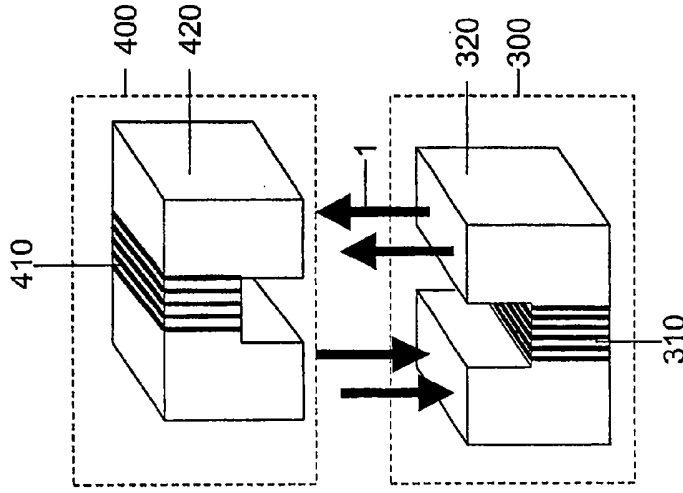

Figure 1b
(Prior Art)

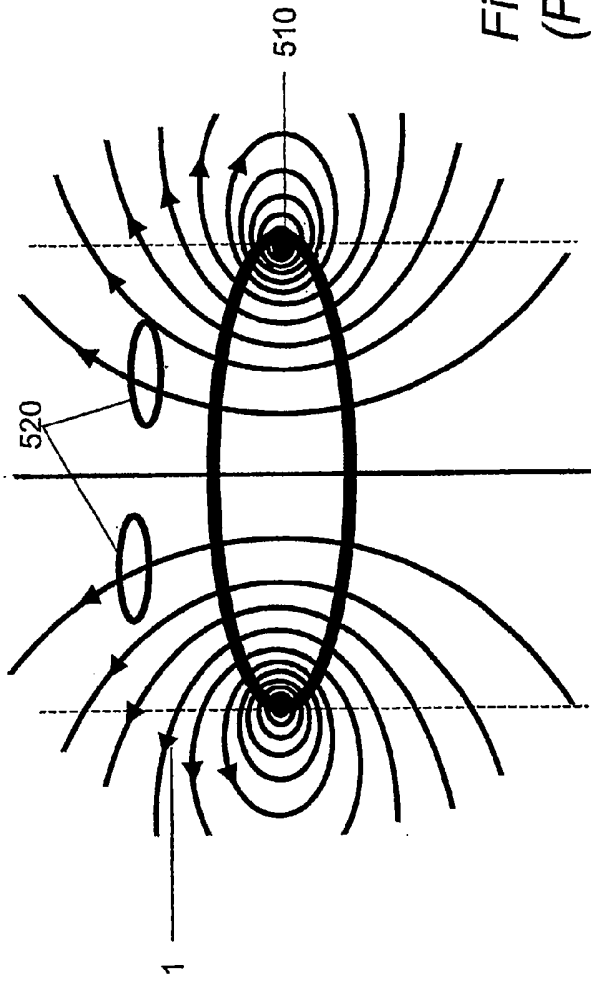

Figure 2a
(Prior Art)

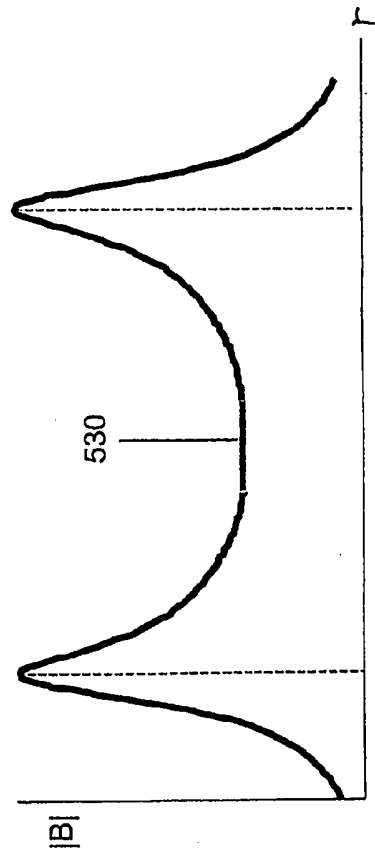

Figure 2b

X = 5mm

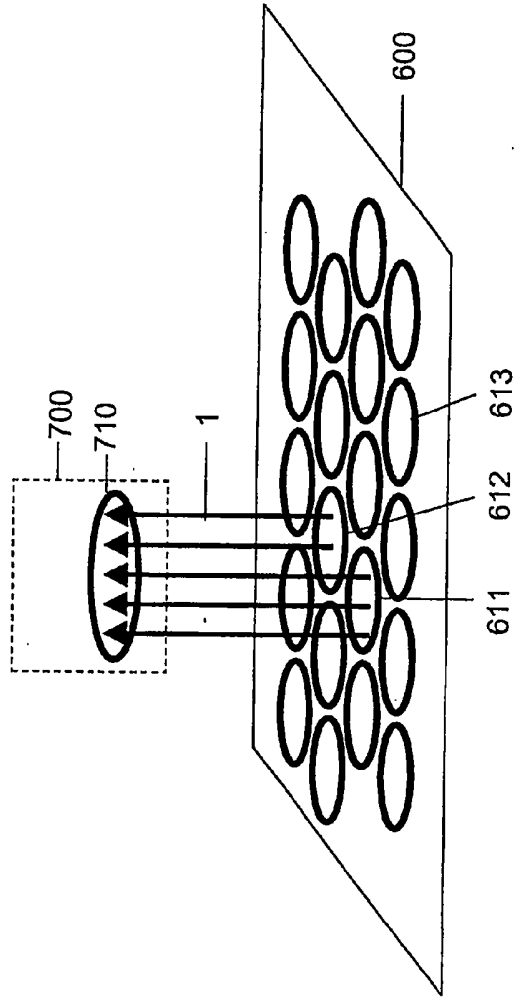

Figure 3

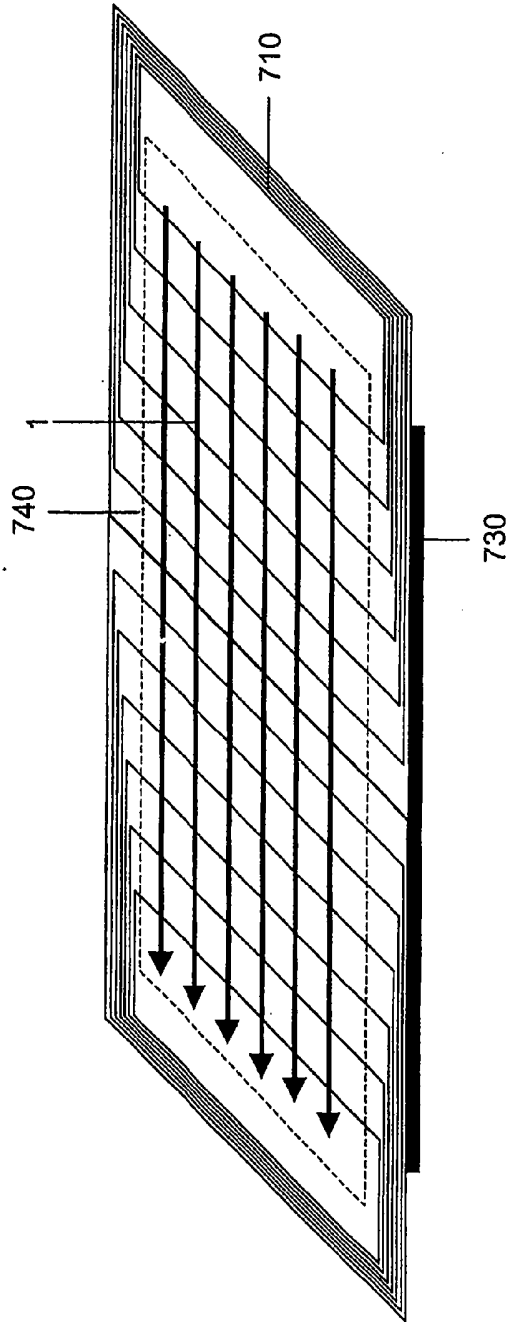

Figure 4a

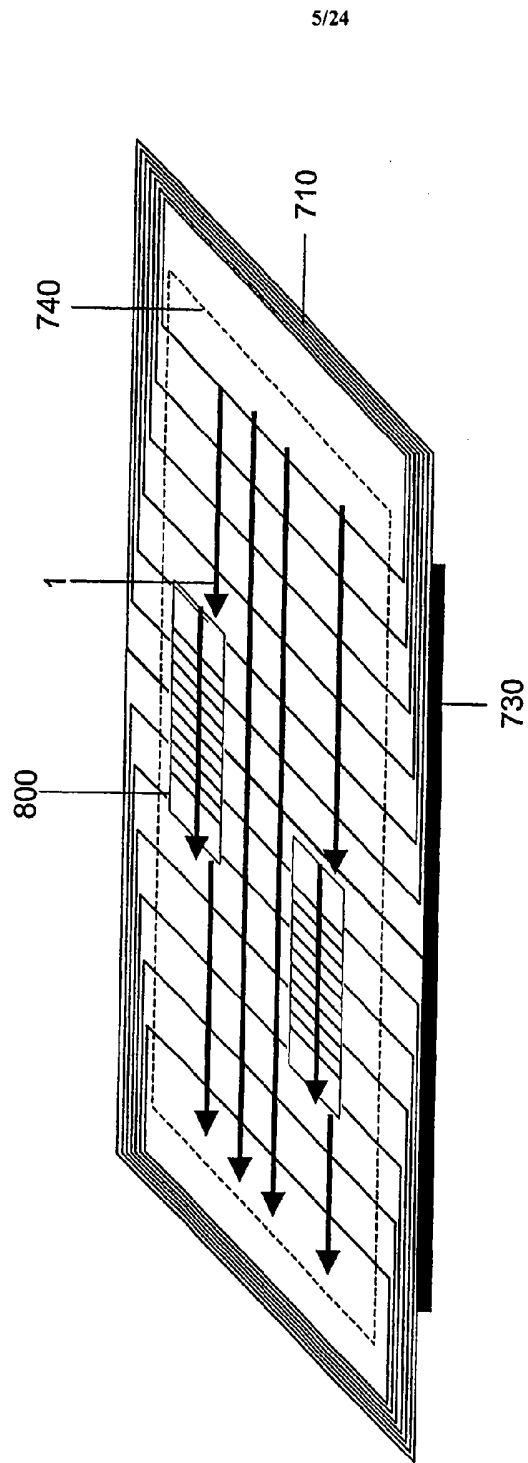

Figure 4b

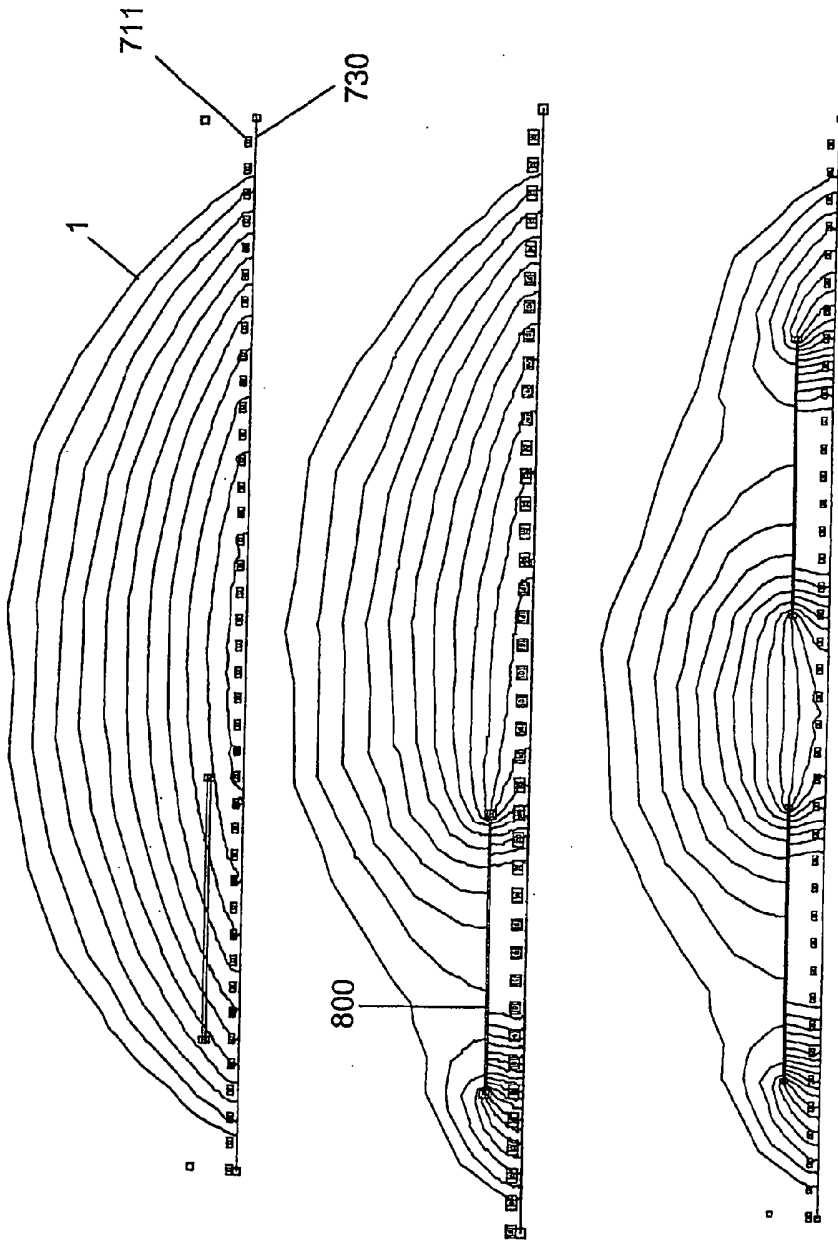

Figure 4c

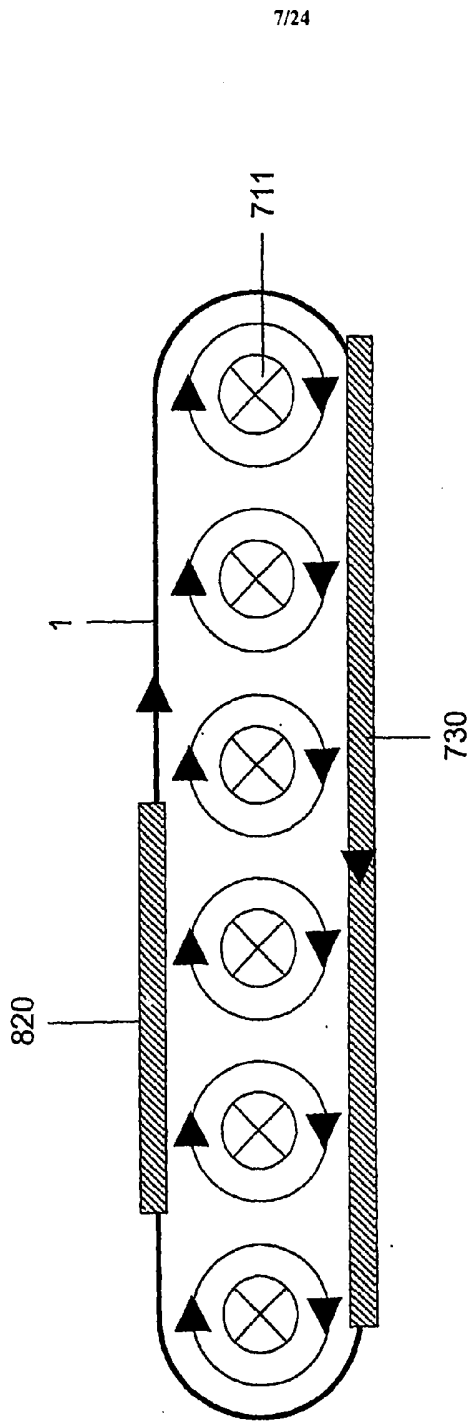

Figure 4d

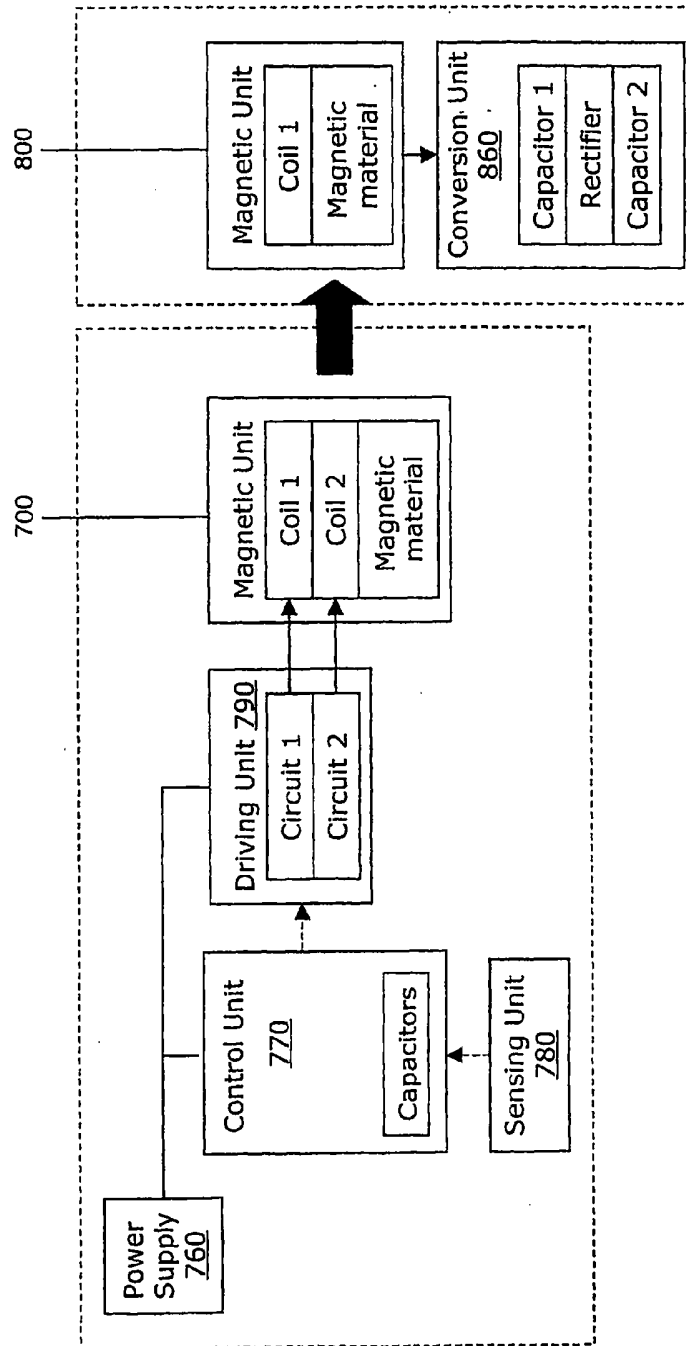

Figure 5

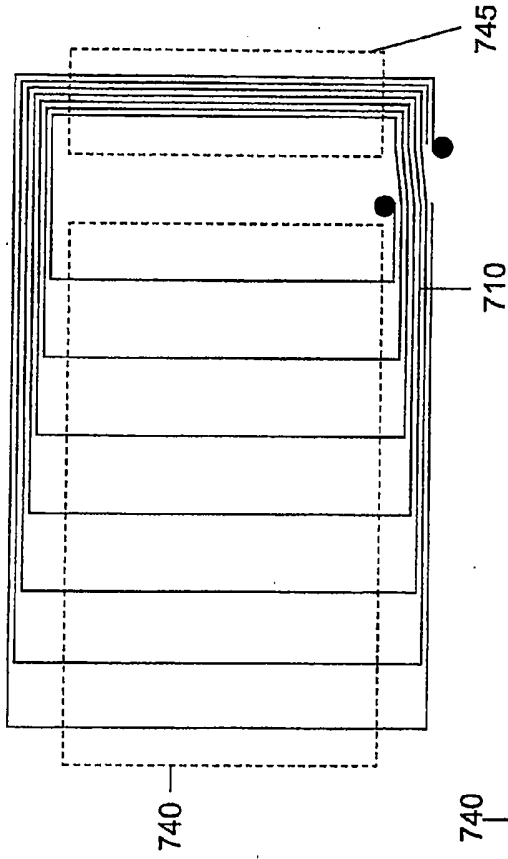

Figure 6a

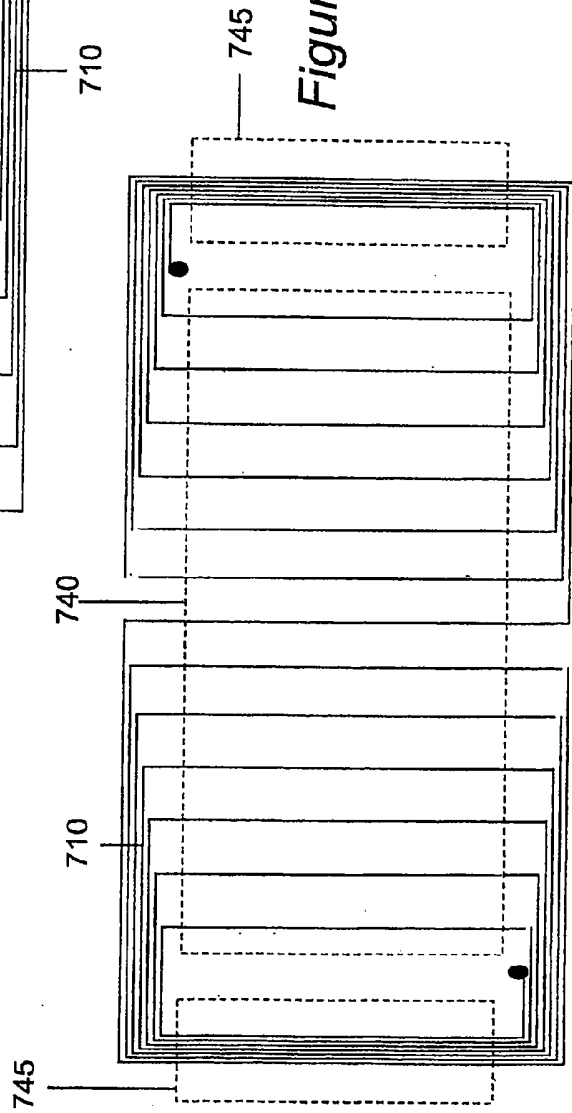

Figure 6b

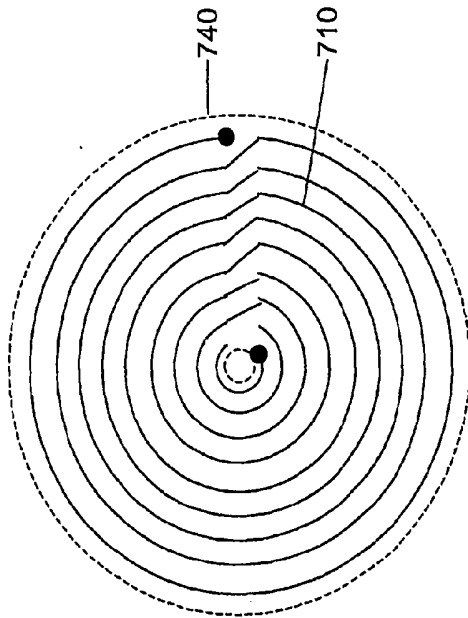

Figure 6c

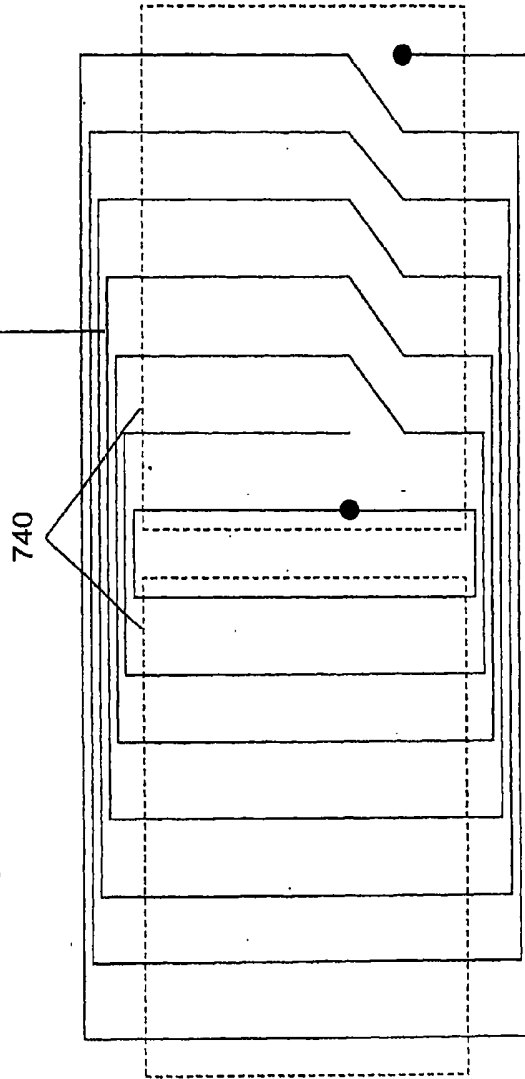

Figure 6d

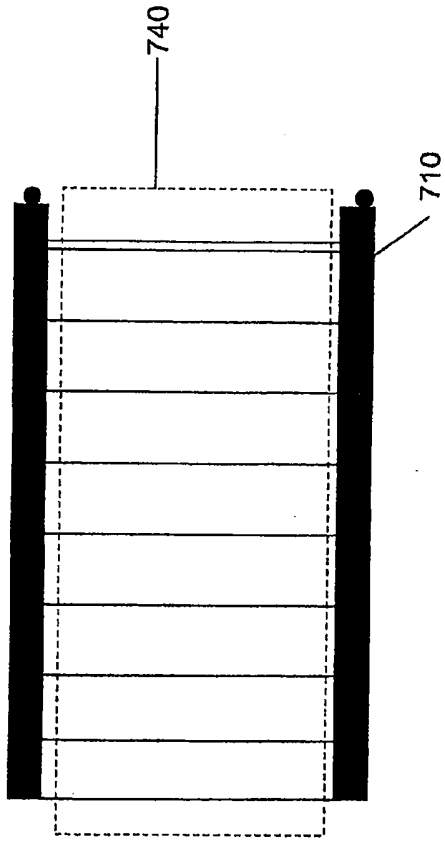

Figure 6e

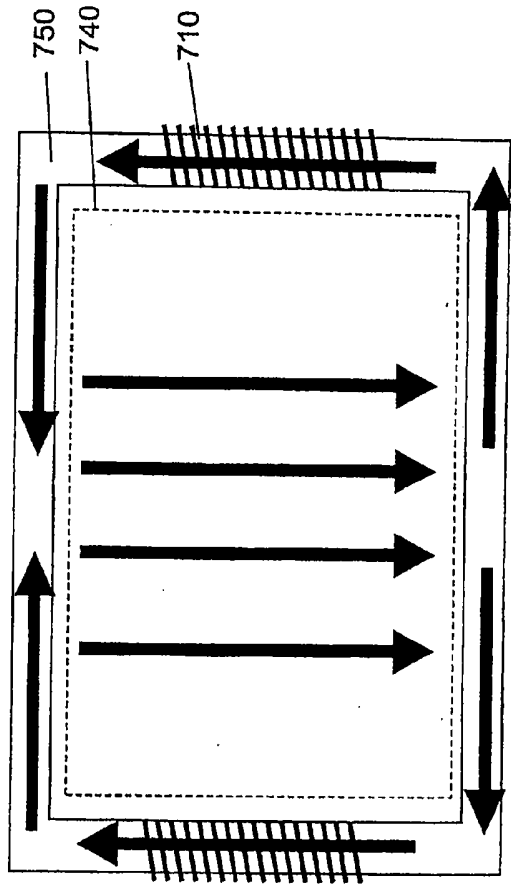

Figure 6f

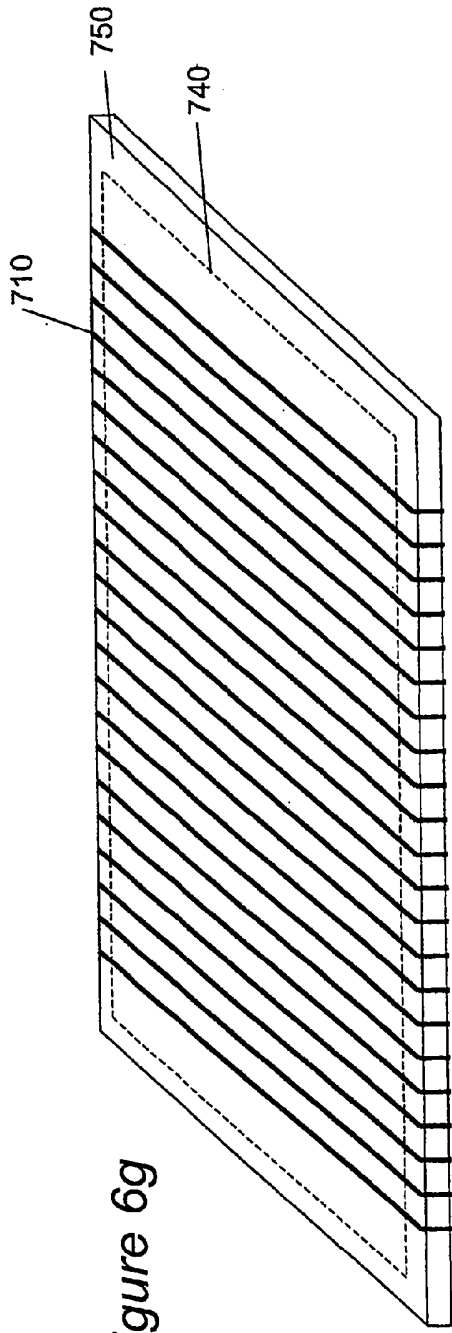

Figure 6g

710

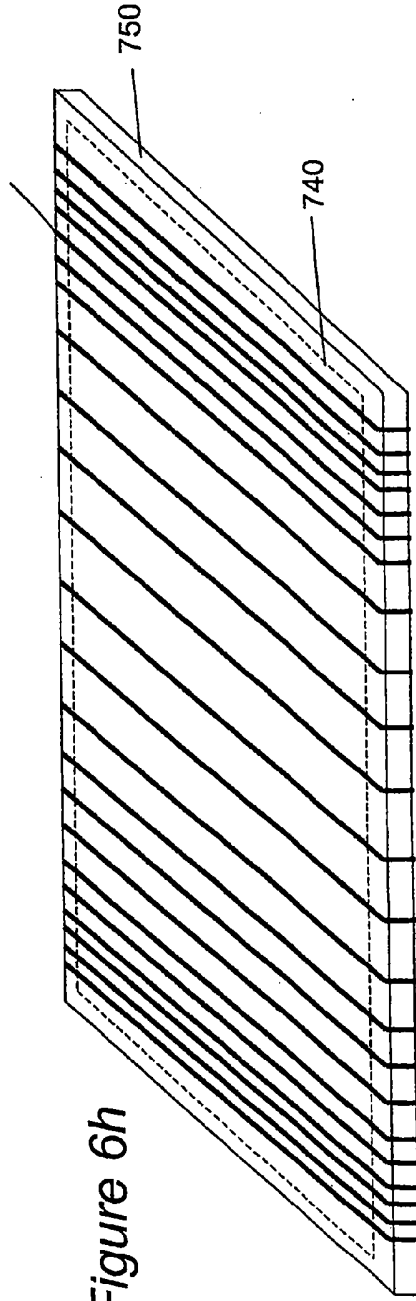

Figure 6h

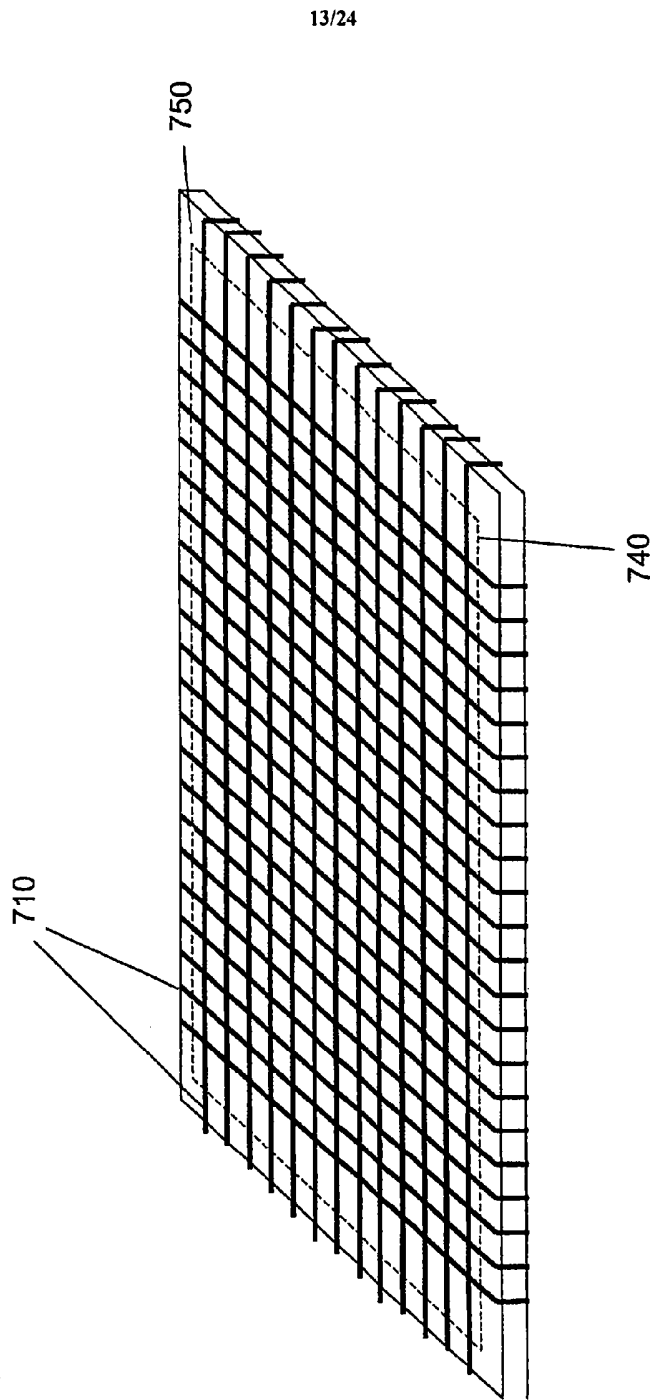

Figure 6i

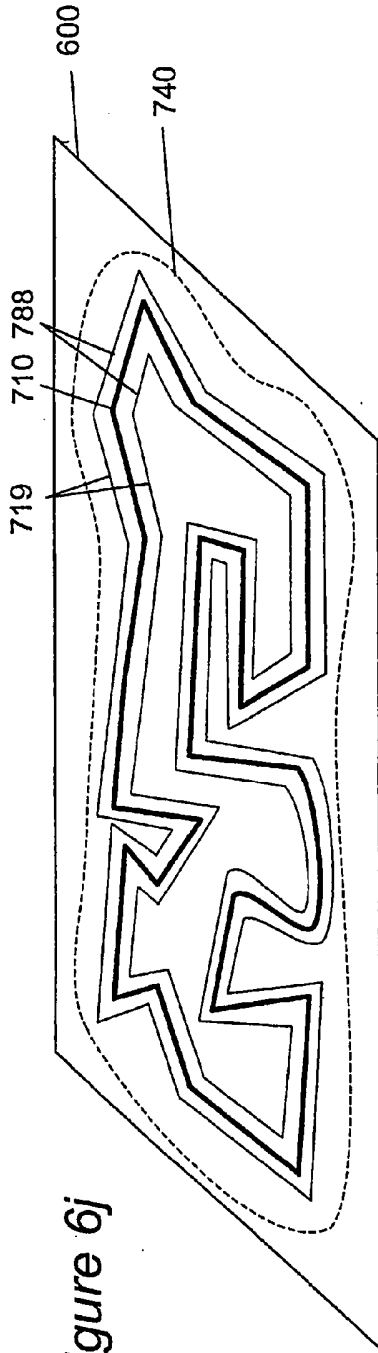

Figure 6j

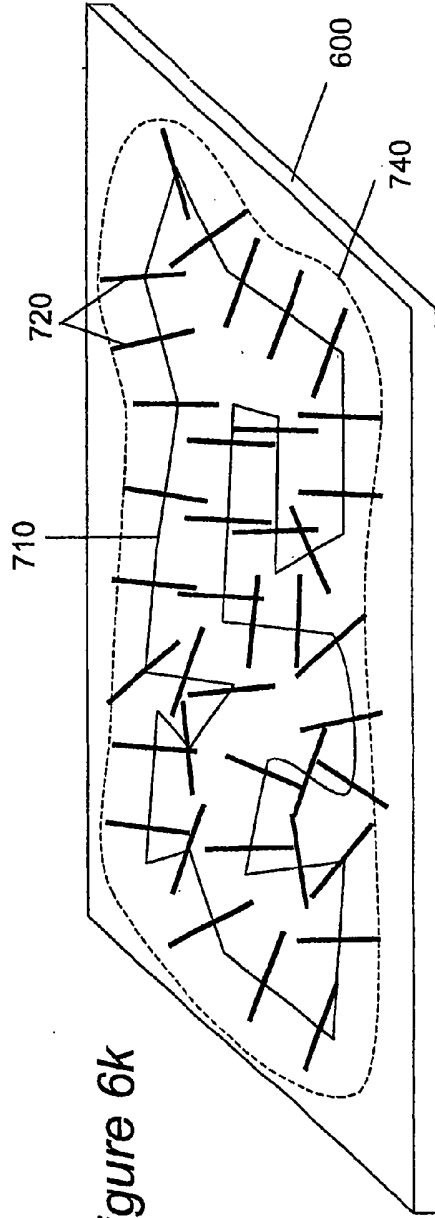

Figure 6k

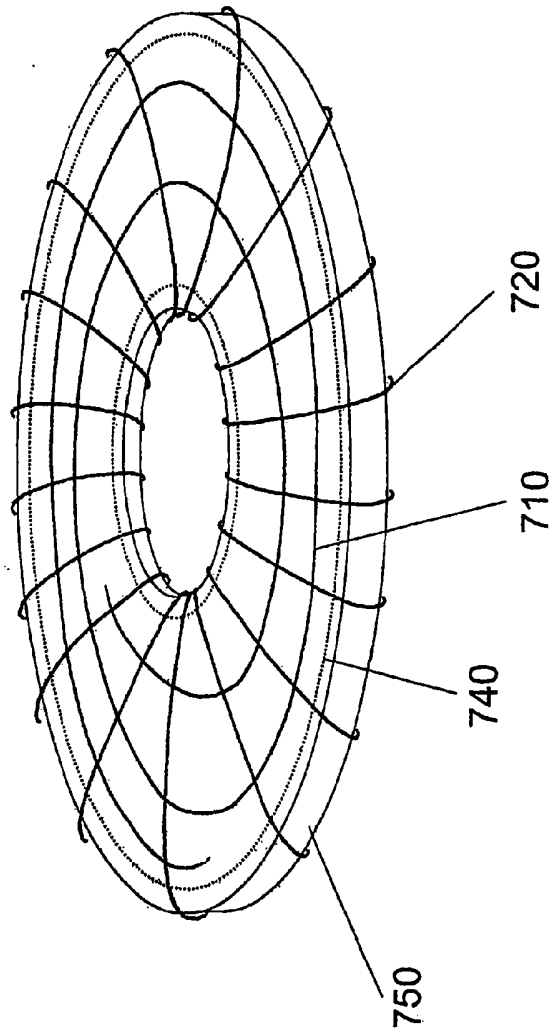

Figure 6L

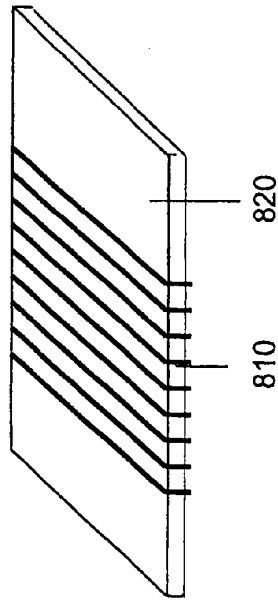

Figure 7a

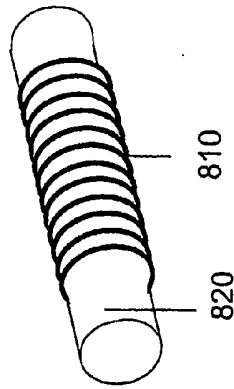

Figure 7b

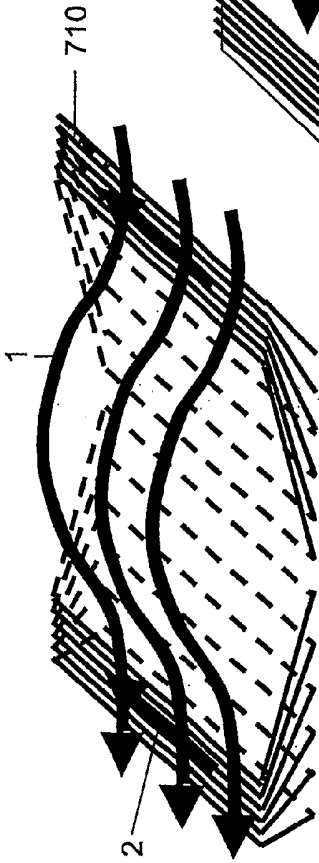

Figure 8a

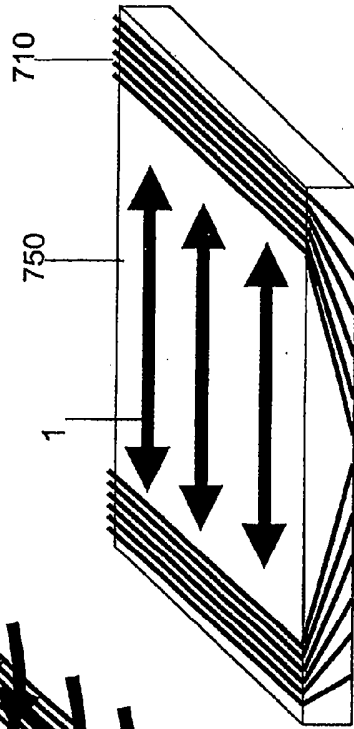

Figure 8c

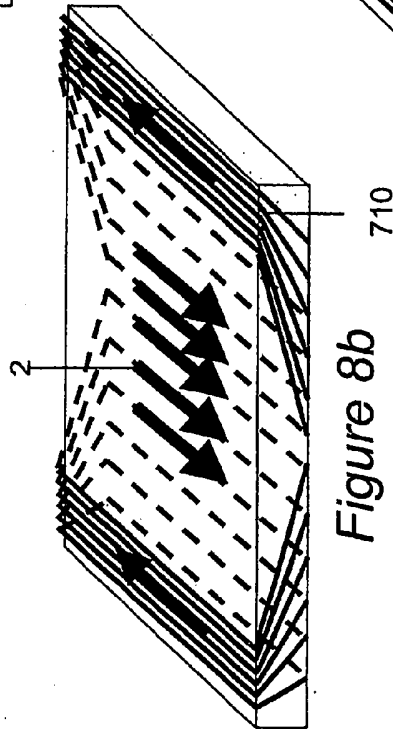

Figure 8b

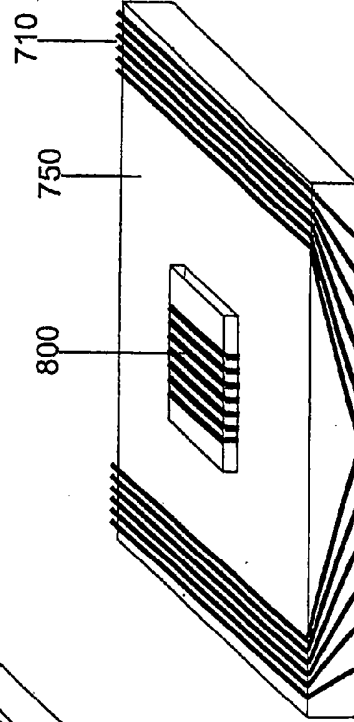

Figure 8d

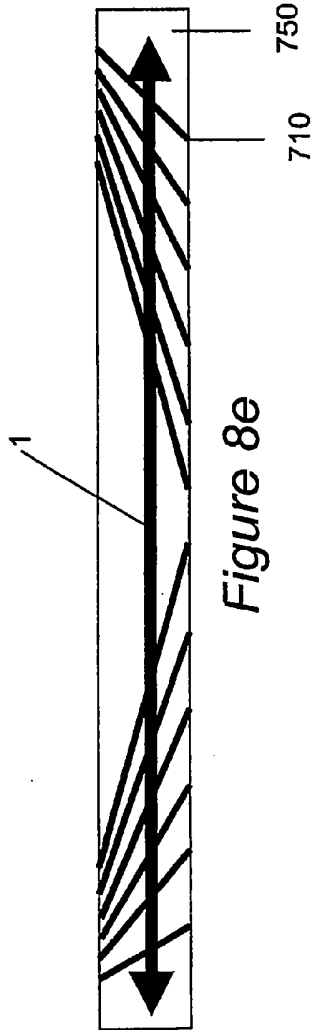

Figure 8e

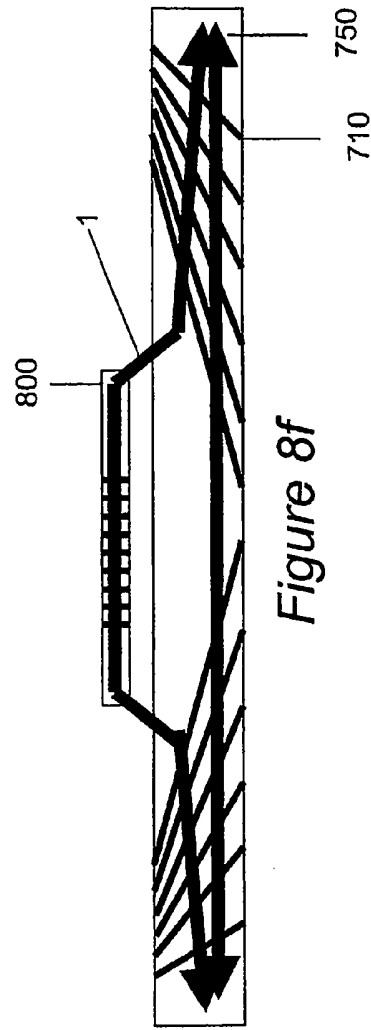

Figure 8f

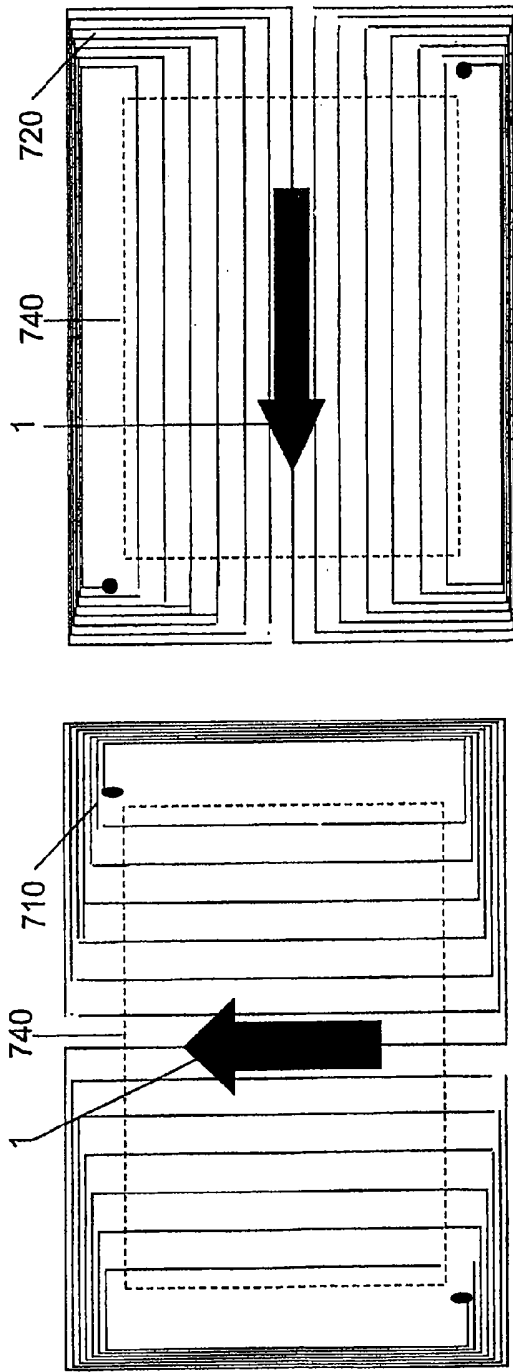

Figure 9a

Figure 9b

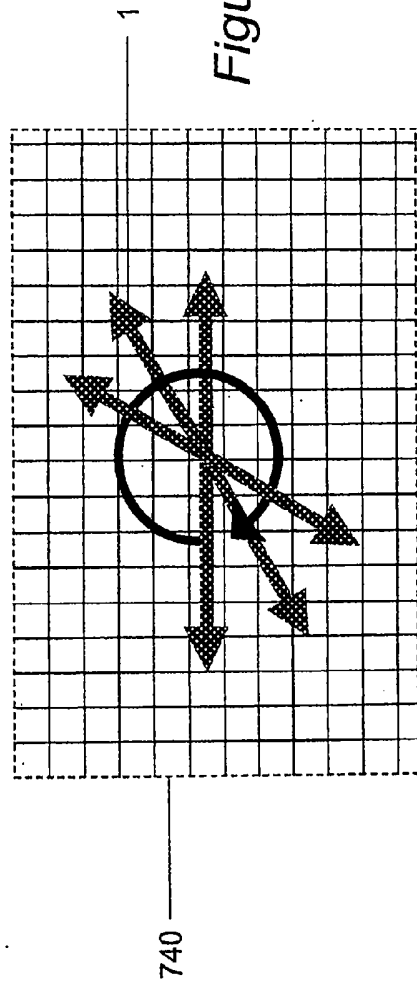

Figure 9c

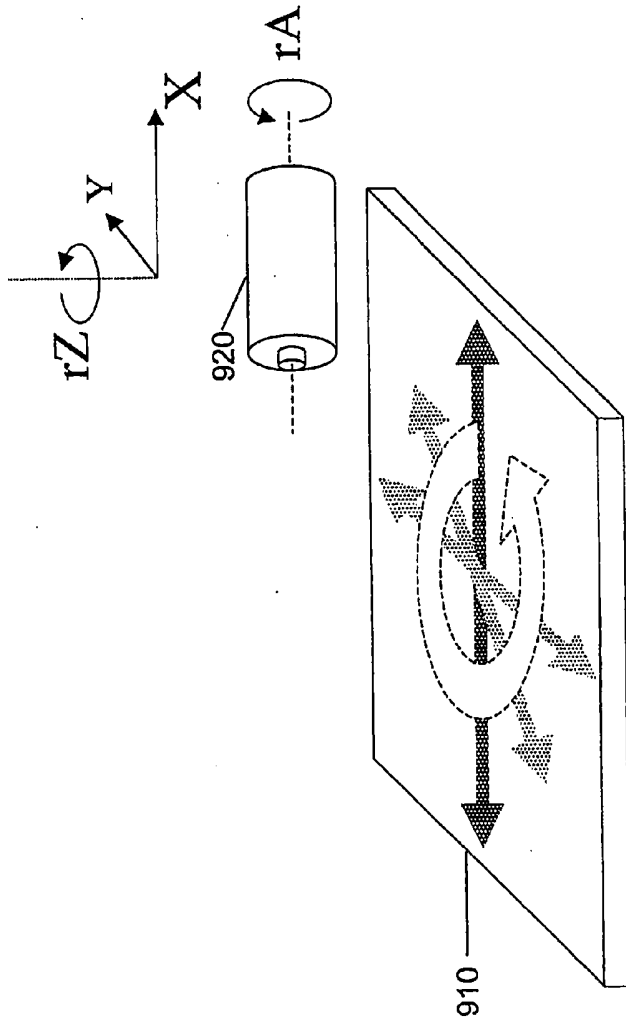

Figure 10

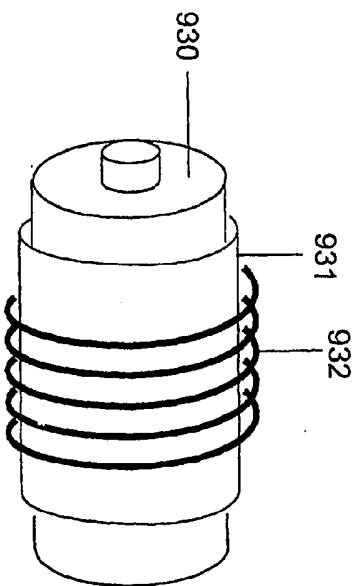

Figure 11a

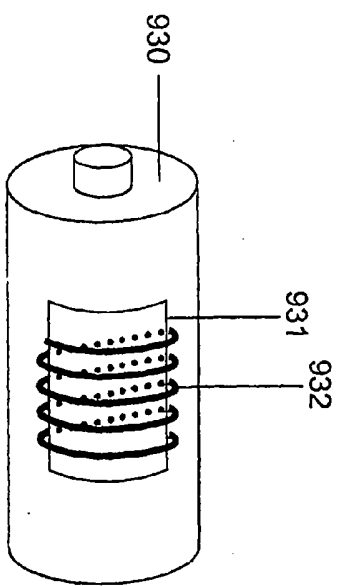

Figure 11b

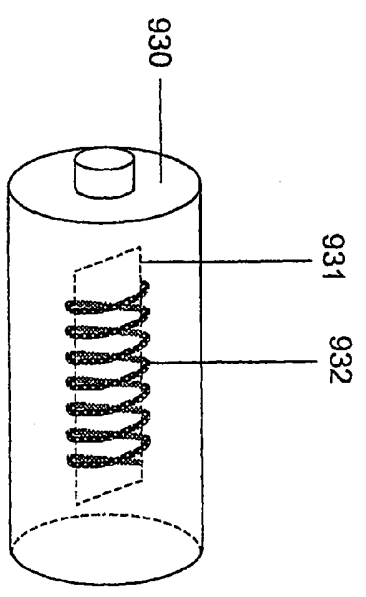
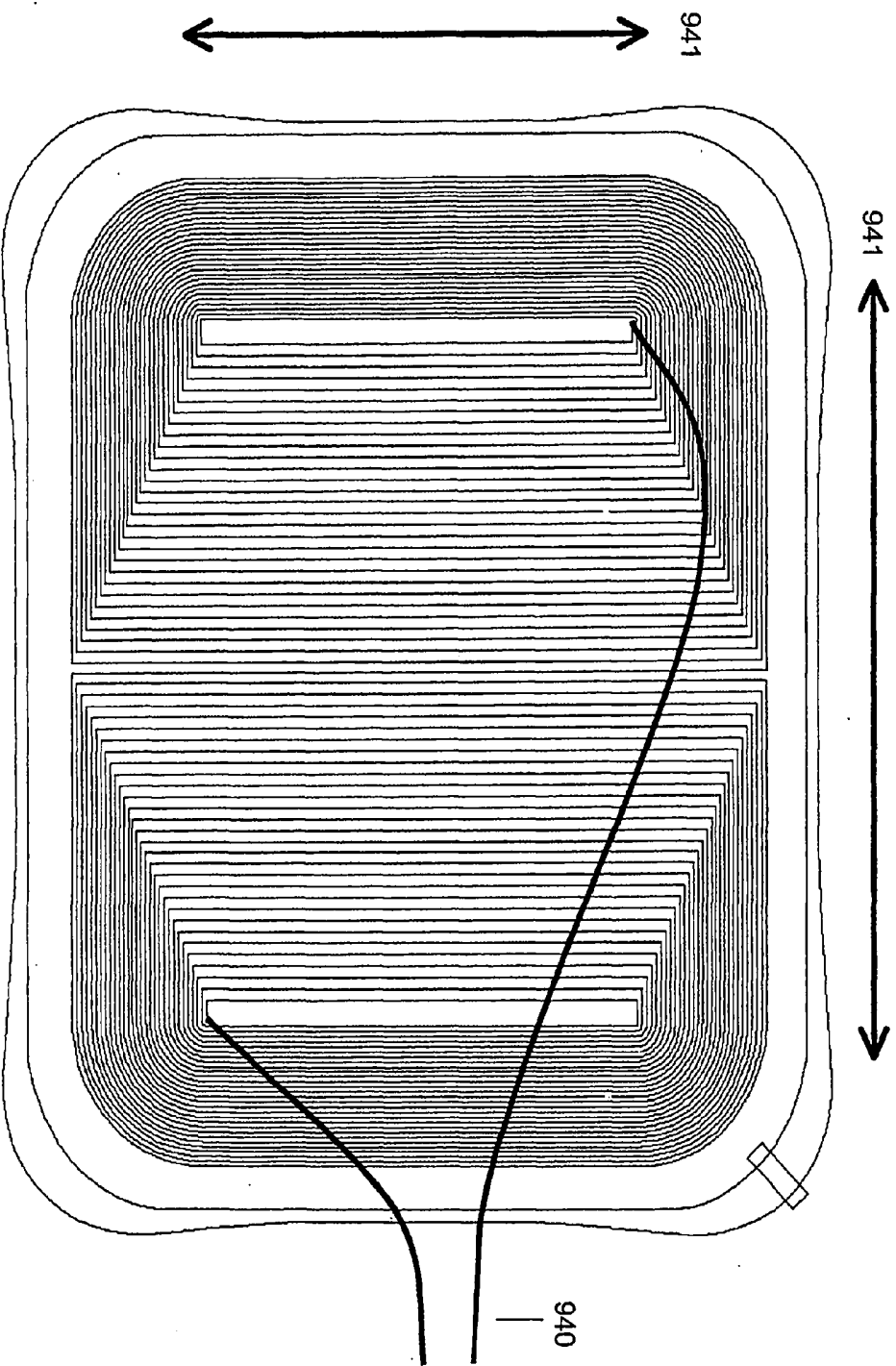

Figure 11c

21/24



22/24

Figure 12a

2008 Dec 50 8515528007

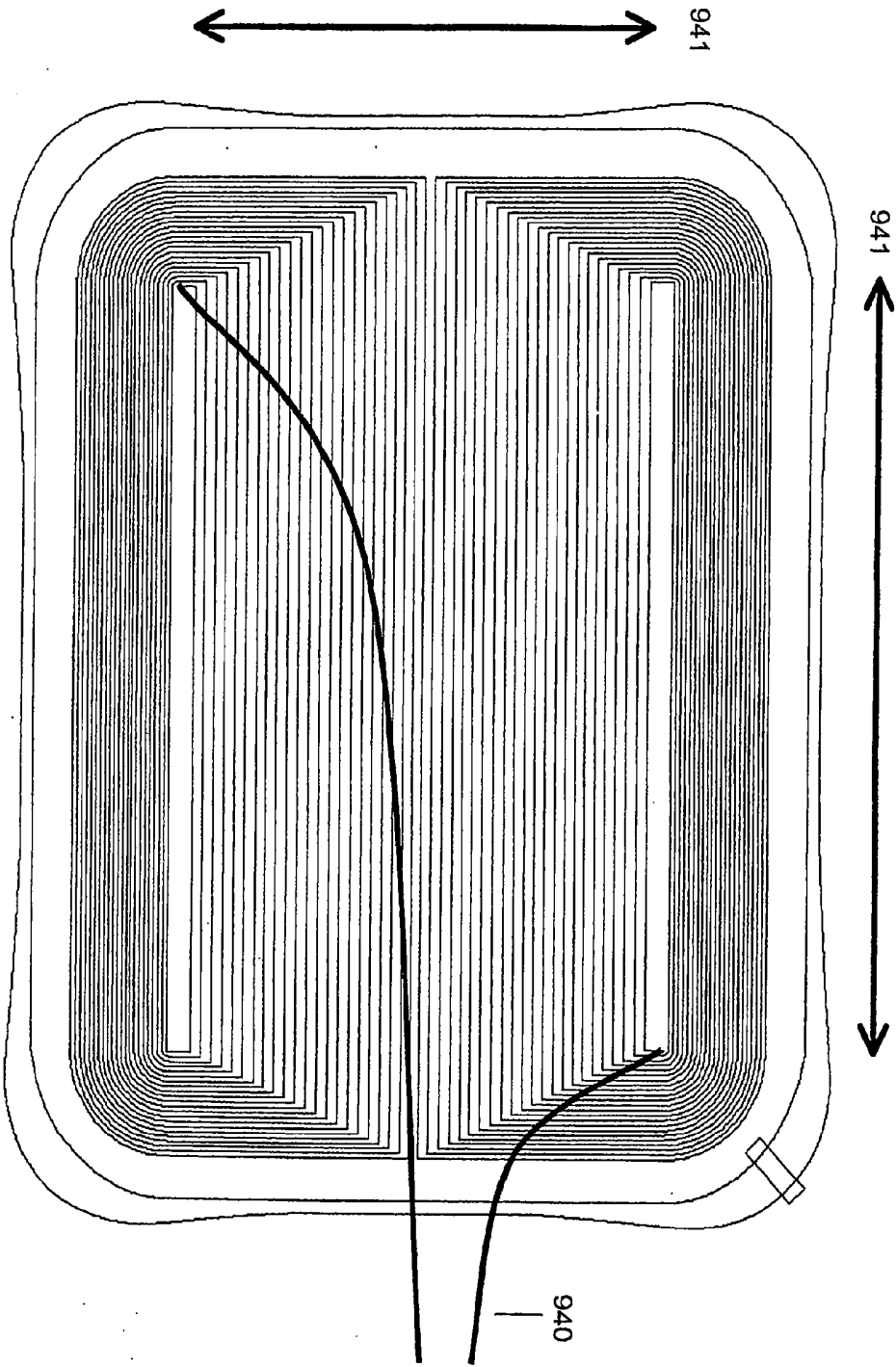

23/24

Figure 12b

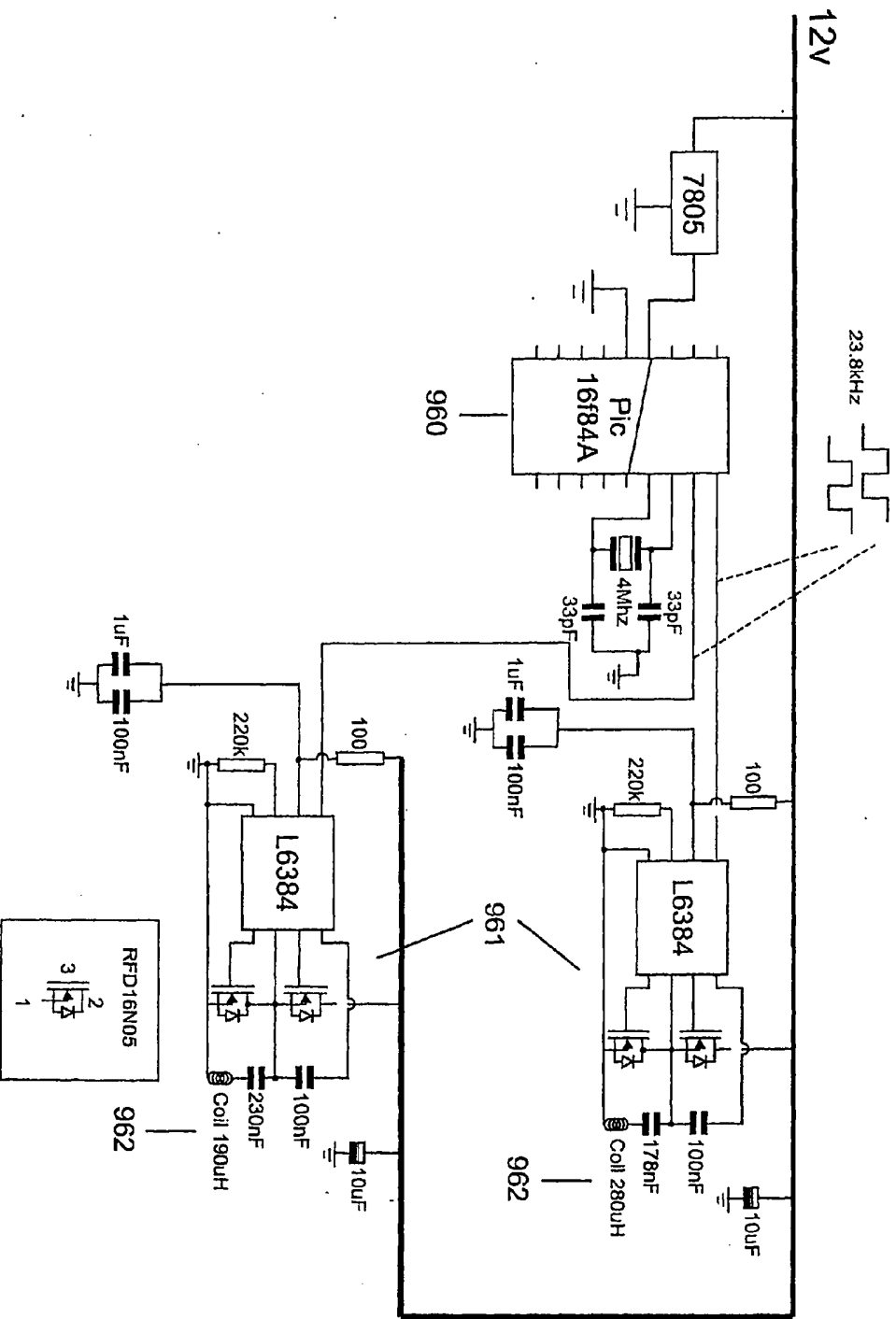

24/24

Figure 13