

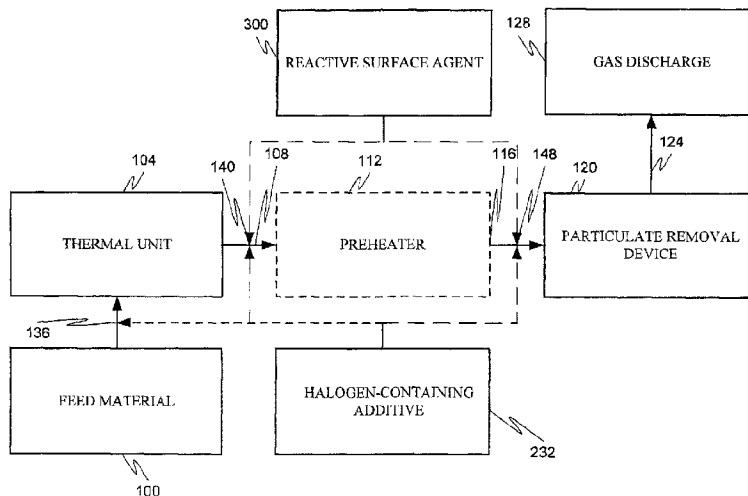

(22) **Date de dépôt/Filing Date:** 2012/10/25
(41) **Mise à la disp. pub./Open to Public Insp.:** 2013/04/25
(45) **Date de délivrance/Issue Date:** 2020/03/24
(30) **Priorité/Priority:** 2011/10/25 (US13/281,066)

(51) **Cl.Int./Int.Cl. B01D 53/64** (2006.01)
(72) **Inventeurs/Inventors:**
DURHAM, MICHAEL D., US;
SJOSTROM, SHARON J., US;
BALDREY, KENNETH E., US
(73) **Propriétaire/Owner:**
ADA-ES, INC., US
(74) **Agent:** GOWLING WLG (CANADA) LLP

(54) **Titre : METHODE ET SYSTEME COTE CHAUD**
(54) **Title: HOT-SIDE METHOD AND SYSTEM**



(57) **Abrégé/Abstract:**

A process for reducing mercury emissions through a low-level addition of a halogen to a mercury-containing feed material, such as coal, in which the halogen is added prior to combustion. Combustion of the mercury-containing feed material having the added halogen produces a gas stream containing a vapor-phase halogen that is generated from the added halogen, and vapor-phase elemental mercury. The mercury-containing gas stream is brought into contact with a reactive surface agent, and the vapor-phase halogen converts the vapor-phase elemental mercury into an ionic mercury. The ionic mercury is collected by the reactive surface agent for removal thereof from the mercury-containing gas stream.

ABSTRACT

A process for reducing mercury emissions through a low-level addition of a halogen to a mercury-containing feed material, such as coal, in which the halogen is added prior to combustion. Combustion of the mercury-containing feed material having the added halogen produces a gas stream containing a vapor-phase halogen that is generated from the added halogen, and vapor-phase elemental mercury. The mercury-containing gas stream is brought into contact with a reactive surface agent, and the vapor-phase halogen converts the vapor-phase elemental mercury into an ionic mercury. The ionic mercury is collected by the reactive surface agent for removal thereof from the mercury-containing gas stream.

EDC_LAW\ 1765771\2

HOT-SIDE METHOD AND SYSTEM

FIELD

The disclosure relates generally to controlling mercury emissions and particularly
5 to controlling mercury emissions using halogen-containing additives.

BACKGROUND

In response to the acknowledged threat that mercury poses to human health and the
environment as a whole, both federal and state/provincial regulation have been
10 implemented in the United States and Canada to permanently reduce mercury emissions,
particularly from coal-fired utilities (e.g., power plants), steel mills, cement kilns, waste
incinerators and boilers, industrial coal-fired boilers, and other coal combusting facilities.
For example, about 40% of mercury introduced into the environment in the U.S. comes
15 from coal-fired power plants. New coal-fired power plants will have to meet stringent
new source performance standards. In addition, Canada and more than 12 states have
enacted mercury control rules with targets of typically 90% control of coal-fired mercury
emissions and other states are considering regulations more stringent than federal
regulations. Further U.S. measures will likely require control of mercury at more stringent
rates as part of new multi-pollutant regulations for all coal-fired sources.

20 The leading technology for mercury control from coal-fired power plants is
activated carbon injection ("ACI"). ACI is the injection of powdered carbonaceous
sorbents, particularly powdered activated carbon ("PAC"), upstream of either an
electrostatic precipitator or a fabric filter bag house. Activated or active carbon is a
porous carbonaceous material having a high adsorptive power.

25 Activated carbon can be highly effective in capturing oxidized (as opposed to
elemental) mercury. Most enhancements to ACI have used halogens to oxidize gas-phase
elemental mercury so it can be captured by the carbon surface. ACI technology has
potential application to the control of mercury emissions on most coal-fired power plants,
even those plants that may achieve some mercury control through control devices
30 designed for other pollutants, such as wet or dry scrubbers for the control sulfur dioxide.

ACI is a low capital cost technology. The largest cost element is the cost of
sorbents. However, ACI has inherent disadvantages that are important to some users.
First, ACI is normally not effective at plants configured with hot-side electrostatic

precipitators or higher temperature cold-side electrostatic precipitators, because the temperature at which the particulates are collected is higher than the temperature at which the carbon adsorbs the mercury. Second, activated carbon is less effective for plants firing high- or medium-sulfur coal, plants using selective catalytic reduction (SCR) systems to control nitrogen oxide emissions where sulfur dioxide may be converted to sulfur trioxide at the catalyst surface and plants using sulfur trioxide flue gas conditioning due to the interference of sulfur trioxide with capture of mercury on the carbon surface.

Another technique to control mercury emissions from coal-fired power plants is bromine injection with ACI. Such a mercury control system is sold by Alstom Power Inc. under the trade names Mer-Cure™ or KNX™ and by Nalco Mobotec Company under the trade name MerControl 7895™. Bromine is believed to oxidize elemental mercury and form mercuric bromide. To remove mercury effectively, bromine injection is done at high rates, typically above 100 ppmw of the coal. At 100 ppmw without ACI or other factors such as high unburned carbon from coal combustion or the presence of a flue gas desulfurization system, bromine has been reported as resulting in a change of mercury emissions of about 40% lower than the uncontrolled mercury.

Bromine, when added at high concentrations such as 100 ppmw of the coal feed, is problematic for at least two reasons. It can form HBr in the flue gas, which is highly corrosive to plant components, such as ductwork. In particular, cold surfaces in the gas path, such as air preheater internals, outlet ductwork, scrubber and stack liners, are very susceptible to corrosion attack. Also at such high injection rates, a significant amount of bromine will be emitted from the stack and into the environment. Bromine is a precursor to bromomethane, hydrobromofluorocarbons, chlorobromomethane and methyl bromide, which are known ozone depletors in the earth's upper atmosphere.

25

SUMMARY

These and other needs are addressed by the various aspects, embodiments, and configurations of the present disclosure. The aspects, embodiments, and configurations are directed generally to the conversion of gas-phase mercury to a form that is more readily captured.

30

In one aspect, a method is provided that includes the steps:

(a) generating from a mercury-containing feed material a mercury-containing gas stream comprising vapor-phase elemental mercury and a vapor-phase halogen;

(b) contacting at least one of the mercury-containing feed material and the mercury-containing gas stream with a reactive surface agent upstream of an air preheater, reactive surface agent and vapor phase halogen converting elemental mercury into ionic mercury and collecting the ionic mercury on the reactive surface agent; and

5 (c) removing the ionic mercury active agent and reactive surface agent from the mercury-containing gas stream.

An advantage of this aspect is temperature stability. Introducing halogens with the coal with subsequent carbonaceous reactive surface agent (e.g., activated carbon) injection can result in superior temperature stability of the collected particulate compared to the use
10 of bromine-treated reactive surface agent, for example. This can particularly be true when the activated carbon is brominated with a salt.

In one aspect, a method is provided that includes the steps:

(a) providing a mercury-containing gas stream comprising vapor-phase elemental mercury;

15 (b) contacting the mercury-containing gas stream with a carbonaceous reactive surface agent upstream of an air preheater, the reactive surface agent comprising at least one of iodine and bromine to collect the ionic mercury on the reactive surface agent; and

(c) removing the mercury-loaded reactive surface agent from the gas stream.

The combined halogen and reactive surface agent can not only be cost effective but
20 also efficacious, at surprisingly low concentrations, in promoting the removal of both elemental and speciated mercury from mercury-containing gas streams. Compared to bromine and iodine in the absence of a reactive surface agent, the reactive surface agent has been found to cost effectively promote the formation of particle-bound mercury species at relatively high temperatures.

25 Very low levels of halogen can enable or facilitate removal of mercury effectively in coal-fired systems, if excessively high acid gas species can be controlled. Mercury will generally not be removed effectively by carbon sorbents or on fly ash in the presence of higher sulfur trioxide and/or nitrogen dioxide concentrations in the mercury-containing gas stream. A high concentration of acid gases (which high partial pressure typically
30 refers to a trioxide concentration of at least about 5 ppmv in the mercury-containing gas stream and even more typically of at least about 10 ppmv and/or a nitrogen dioxide concentration of at least about 5 ppmv and even more typically at least about 10 ppmv).

The higher sulfur trioxide concentration can be due to sulfur levels in the feed material, catalytic oxidation of sulfur dioxide to sulfur trioxide across the SCR and/or where SO₃ is injected to improve performance of the particulate removal device. The condensation temperature of sulfur trioxide and/or nitrogen dioxide on a collection or sorbent surface
5 can be lower than the condensation temperatures of mercuric iodide and periodic acid. As noted, condensed acid can displace sorbed mercury from a carbon sorbent particle surface.

By forming a mercury-containing particulate that can be collected in an electrostatic precipitator or baghouse or reacting with collected particulate, the mercury can be removed prior to entering the wet scrubber. This can eliminate the potential for re-
10 mission of elemental mercury from the scrubber, which is extremely difficult to control for variable process conditions. It can also reduce or eliminate mercury from the scrubber sludge.

When halogens are introduced with the feed material, the collected mercury appears to be much more temperature stable than collected mercury caused by
15 introduction of halogens into the flue gas. Introducing halogens with coal, for example, with subsequent ACI injection seems to result in much better temperature stability of the mercury associated with the collected particulate than when bromine-treated activated carbon is used, particularly when the activated carbon is brominated with a salt.

Stability of captured mercury in fly ash or other retained particulate solids is
20 related to leachability and solubility of the mercury. Mercuric iodide, HgI₂, has a very low solubility in water, which is significantly different from (less soluble than) other oxidized mercury species such as HgCl₂ and HgBr₂. The solubility in water is more than two orders of magnitude lower than bromide or chloride species: HgCl₂ is 73.25 g/l, HgBr₂ is 6.18 g/l, HgI₂ is 0.06 g/l and Hg^o is 5.73 x 10⁻⁰⁵ g/l. The lower solubility of captured HgI₂
25 will reduce the leachability in fly ash and other solid particulates compared to other oxidized mercury species.

These and other advantages will be apparent from the disclosure of the aspects, embodiments, and configurations contained herein.

"A" or "an" entity refers to one or more of that entity. As such, the terms "a" (or
30 "an"), "one or more" and "at least one" can be used interchangeably herein. It is also to be noted that the terms "comprising", "including", and "having" can be used interchangeably.

"Absorption" is the incorporation of a substance in one state into another of a different state (e.g. liquids being absorbed by a solid or gases being absorbed by a liquid).

Absorption is a physical or chemical phenomenon or a process in which atoms, molecules, or ions enter some bulk phase - gas, liquid or solid material. This is a different process from adsorption, since molecules undergoing absorption are taken up by the volume, not by the surface (as in the case for adsorption).

5 "Adsorption" is the adhesion of atoms, ions, biomolecules, or molecules of gas, liquid, or dissolved solids to a surface. This process creates a film of the adsorbate (the molecules or atoms being accumulated) on the surface of the adsorbent. It differs from absorption, in which a fluid permeates or is dissolved by a liquid or solid. Similar to surface tension, adsorption is generally a consequence of surface energy. The exact nature
10 of the bonding depends on the details of the species involved, but the adsorption process is generally classified as physisorption (characteristic of weak van der Waals forces) or chemisorption (characteristic of covalent bonding). It may also occur due to electrostatic attraction.

"Ash" refers to the residue remaining after complete combustion of the coal
15 particles. Ash typically includes mineral matter (silica, alumina, iron oxide, etc.).

"At least one", "one or more", and "and/or" are open-ended expressions that are both conjunctive and disjunctive in operation. For example, each of the expressions "at least one of A, B and C", "at least one of A, B, or C", "one or more of A, B, and C", "one or more of A, B, or C" and "A, B, and/or C" means A alone, B alone, C alone, A and B
20 together, A and C together, B and C together, or A, B and C together. When each one of A, B, and C in the above expressions refers to an element, such as X, Y, and Z, or class of elements, such as X_1 - X_n , Y_1 - Y_m , and Z_1 - Z_o , the phrase is intended to refer to a single element selected from X, Y, and Z, a combination of elements selected from the same class (e.g., X_1 and X_2) as well as a combination of elements selected from two or more
25 classes (e.g., Y_1 and Z_o).

"Biomass" refers to biological matter from living or recently living organisms. Examples of biomass include, without limitation, wood, waste, (hydrogen) gas, seaweed, algae, and alcohol fuels. Biomass can be plant matter grown to generate electricity or heat. Biomass also includes, without limitation, plant or animal matter used for
30 production of fibers or chemicals. Biomass further includes, without limitation, biodegradable wastes that can be burnt as fuel but generally excludes organic materials, such as fossil fuels, which have been transformed by geologic processes into substances such as coal or petroleum. Industrial biomass can be grown from numerous types of

plants, including miscanthus, switchgrass, hemp, corn, poplar, willow, sorghum, sugarcane, and a variety of tree species, ranging from eucalyptus to oil palm (or palm oil).

"Carbonaceous" refers to a carbon-containing material, particularly a material that is substantially rich in carbon.

5 "Coal" refers to a combustible material formed from prehistoric plant life. Coal includes, without limitation, peat, lignite, sub-bituminous coal, bituminous coal, steam coal, anthracite, and graphite. Chemically, coal is a macromolecular network comprised of groups of polynuclear aromatic rings, to which are attached subordinate rings connected by oxygen, sulfur, and aliphatic bridges.

10 A "composition" refers to one or more chemical units composed of one or more atoms, such as a molecule, polyatomic ion, chemical compound, coordination complex, coordination compound, and the like. As will be appreciated, a composition can be held together by various types of bonds and/or forces, such as covalent bonds, metallic bonds, coordination bonds, ionic bonds, hydrogen bonds, electrostatic forces (e.g., van der Waal's
15 forces and London's forces), and the like.

"Halogen" refers to an electronegative element of group VIIA of the periodic table (e.g., fluorine, chlorine, bromine, iodine, astatine, listed in order of their activity with fluorine being the most active of all chemical elements).

"Halide" refers to a binary compound of the halogens.

20 "High alkali coals" refer to coals having a total alkali (e.g., calcium) content of at least about 20 wt.% (dry basis of the ash), typically expressed as CaO, while "low alkali coals" refer to coals having a total alkali content of less than 20 wt.% and more typically less than about 15 wt.% alkali (dry basis of the ash), typically expressed as CaO.

"High iron coals" refer to coals having a total iron content of at least about 10 wt.%
25 (dry basis of the ash), typically expressed as Fe_2O_3 , while "low iron coals" refer to coals having a total iron content of less than about 10 wt.% (dry basis of the ash), typically expressed as Fe_2O_3 . As will be appreciated, iron and sulfur are typically present in coal in the form of ferrous or ferric carbonates and/or sulfides, such as iron pyrite.

"High sulfur coals" refer to coals having a total sulfur content of at least about 1.5
30 wt.% (dry basis of the coal) while "medium sulfur coals" refer to coals having between about 1.5 and 3 wt.% (dry basis of the coal) and "low sulfur coals" refer to coals typically having a total sulfur content of less than about 1.5 wt.% (dry basis of the coal), more

typically having a total sulfur content of less than about 1.0 wt.%, and even more typically having a total sulfur content of less than about 0.8 wt.% of the coal (dry basis of the coal).

"Ion exchange medium" refers to a medium that is able, under selected operating conditions, to exchange ions between two electrolytes or between an electrolyte solution and a complex. Examples of ion exchange resins include solid polymeric or mineralic "ion exchangers". Other exemplary ion exchangers include ion exchange resins (functionalized porous or gel polymers), zeolites, montmorillonite clay, clay, and soil humus. Ion exchangers are commonly either cation exchangers that exchange positively charged ions (cations) or anion exchangers that exchange negatively charged ions (anions). There are also amphoteric exchangers that are able to exchange both cations and anions simultaneously. Ion exchangers can be unselective or have binding preferences for certain ions or classes of ions, depending on their chemical structure. This can be dependent on the size of the ions, their charge, or their structure. Typical examples of ions that can bind to ion exchangers are: H^+ (proton) and OH^- (hydroxide); single-charged monoatomic ions like Na^+ , K^+ , and Cl^- ; double-charged monoatomic ions like Ca^{2+} and Mg^{2+} ; polyatomic inorganic ions like SO_4^{2-} and PO_4^{3-} ; organic bases, usually molecules containing the amino functional group - NR_2H^+ ; organic acids often molecules containing $-COO^-$ (carboxylic acid) functional groups; and biomolecules that can be ionized: amino acids, peptides, proteins, *etc.*

Mercury Active Agent refers to an additive that oxidizes elemental mercury and/or catalyzes the formation of diatomic halogens.

Neutron Activation Analysis ("NAA") refers to a method for determining the elemental content of samples by irradiating the sample with neutrons, which create radioactive forms of the elements in the sample. Quantitative determination is achieved by observing the gamma rays emitted from these isotopes.

"Oxidizing agent", "oxidant" or "oxidizer" refers to an element or compound that accepts one or more electrons to another species or agent that is oxidized. In the oxidizing process the oxidizing agent is reduced and the other species which accepts the one or more electrons is oxidized. More specifically, the oxidizer is an electron acceptor, or recipient, and the reductant is an electron donor or giver.

"Particulate" refers to fine particles, such as fly ash, unburned carbon, soot and fine process solids, typically entrained in a gas stream.

The phrase "ppmw X" refers to the parts-per-million, based on weight, of X alone. It does not include other substances bonded to X.

The phrase "ppmv X" refers to the parts-per-million, based on volume, of X alone. It does not include other substances bonded to X.

5 "Separating" and cognates thereof refer to setting apart, keeping apart, sorting, removing from a mixture or combination, or isolating. In the context of gas mixtures, separating can be done by many techniques, including electrostatic precipitators, baghouses, scrubbers, and heat exchange surfaces.

10 A "sorbent" is a material that sorbs another substance; that is, the material has the capacity or tendency to take it up by sorption.

"Sorb" and cognates thereof mean to take up a liquid or a gas by sorption.

"Sorption" and cognates thereof refer to adsorption and absorption, while desorption is the reverse of adsorption.

15 The preceding is a simplified summary of the disclosure to provide an understanding of some aspects of the disclosure. This summary is neither an extensive nor exhaustive overview of the disclosure and its various aspects, embodiments, and configurations. It is intended neither to identify key or critical elements of the disclosure nor to delineate the scope of the disclosure but to present selected concepts of the disclosure in a simplified form as an introduction to the more detailed description
20 presented below. As will be appreciated, other aspects, embodiments, and configurations of the disclosure are possible utilizing, alone or in combination, one or more of the features set forth above or described in detail below.

BRIEF DESCRIPTION OF THE DRAWINGS

25 The accompanying drawings are incorporated into and form a part of the specification to illustrate several examples of the present disclosure. These drawings, together with the description, explain the principles of the disclosure. The drawings simply illustrate preferred and alternative examples of how the disclosure can be made and used and are not to be construed as limiting the disclosure to only the illustrated and
30 described examples. Further features and advantages will become apparent from the following, more detailed, description of the various aspects, embodiments, and configurations of the disclosure, as illustrated by the drawings referenced below.

Fig. 1 is a block diagram according to an embodiment;

- Fig. 2 is a block diagram according to an embodiment;
Fig. 3 is a block diagram according to an embodiment;
Fig. 4 is a block diagram according to an embodiment;
Fig. 5 is a block diagram according to an embodiment;
5 Fig. 6 is a block diagram according to an embodiment;
Fig. 7 is a plot of total mercury emissions ($\mu\text{g}/\text{wscm}$) (vertical axis) against time
(horizontal axis);
Fig. 8 is a block diagram according to an embodiment;
Fig. 9 is a block diagram according to an embodiment; and
10 Fig. 10 is a block diagram according to an embodiment.

DETAILED DESCRIPTION

Mercury Removal by Iodine-Containing Additive

The current disclosure is directed to the use of an iodine-containing additive,
15 typically present in relatively low concentrations, to control mercury emissions from vapor
phase mercury evolving facilities, such as smelters, autoclaves, roasters, steel foundries,
steel mills, cement kilns, power plants, waste incinerators, boilers, and other mercury-
contaminated gas stream producing industrial facilities. Although the mercury is typically
evolved by combustion, it may be evolved by other oxidation and/or reducing reactions,
20 such as roasting, autoclaving, and other thermal processes that expose mercury containing
materials to elevated temperatures.

There are a number of possible mechanisms for mercury capture in the presence of
iodine.

While not wishing to be bound by any theory, a path for oxidation of mercury
25 appears to be initiated by one or more reactions of elemental mercury and an iodine
molecule in the form of I_2 . The oxidation reactions may be homogeneous, heterogeneous,
or a combination thereof. For heterogeneous reactions, the reaction or collection surface
can, for example, be an air preheater surface, duct internal surface, an electrostatic
precipitator plate, an alkaline spray droplet, dry alkali sorbent particles, a baghouse filter,
30 an entrained particle, fly ash, carbon particle, or other available surface. It is believed that
iodine can oxidize typically at least most, even more typically at least about 75%, and
even more typically at least about 90% of the elemental mercury in the mercury-
containing gas stream.

Under most flue gas conditions, the mercury reaction kinetics for iodine appear to be faster at higher temperatures than mercury reaction kinetics for chlorine or bromine at the same temperature. With chlorine, almost all the chlorine in the flame is found as HCl, with very little Cl. With bromine, there are, at high temperatures, approximately equal amounts of HBr on the one hand and Br₂ on the other. This is believed to be why oxidation of Hg by bromine is more efficient than oxidation by chlorine. Chemical modeling of equilibrium iodine speciation in a subbituminous flue gas indicates that, at high temperatures, there can be one thousand times less HI than I (in the form of I₂) in the gas. In many applications, the molecular ratio, in the gas phase of a mercury-containing gas stream, of elemental iodine to hydrogen-iodine species (such as HI) is typically at least about 10:1, even more typically at least about 25:1, even more typically at least about 100:1, and even more typically at least about 250:1.

While not wishing to be bound by any theory, the end product of reaction can be mercuric iodide (HgI₂ or Hg₂I₂), which has a higher condensation temperature (and boiling point) than both mercuric bromide (HgBr₂ or Hg₂Br₂) and mercuric chloride (HgCl₂ or Hg₂Cl₂). The condensation temperature (or boiling point) of mercuric iodide (depending on the form) is in the range from about 353 to about 357°C compared to about 322°C for mercuric bromide and about 304 °C for mercuric chloride. The condensation temperature (or boiling point) for iodine (I₂) is about 184 °C while that for bromine (Br₂) is about 58 °C.

While not wishing to be bound by any theory, another possible reaction path is that other mercury compounds are formed by multi-step reactions with iodine as an intermediate. One possible multi-step reaction is that iodine reacts with sulfur oxides to form reduced forms of sulfur, which reduced forms of sulfur then react with mercury and form capturable particulate mercury-sulfur compounds.

As will be appreciated, these theories may not prove to be correct. As further experimental work is performed, the theories may be refined and/or other theories developed. Accordingly, these theories are not to be read as limiting the scope or breadth of this disclosure.

Fig. 1 depicts a contaminated gas stream treatment process for an industrial facility according to an embodiment. Referring to Fig. 1, a mercury-containing feed material 100 is provided. In one application, the feed material 100 is combustible and can be any synthetic or natural, mercury-containing, combustible, and carbon-containing material,

including coal and biomass. The feed material 100 can be a high alkali or high iron coal. In other applications, the present disclosure is applicable to noncombustible, mercury-containing feed materials, including without limitation metal-containing ores, concentrates, and tailings.

5 The feed material 100 can natively include, without limitation, varying levels of halogens and mercury. Typically, the feed material 100 includes typically at least about 0.001 ppmw, even more typically from about 0.003 to about 100 ppmw, and even more typically from about 0.003 to about 10 ppmw mercury (both elemental and speciated) (measured by neutron activation analysis ("NAA")). Commonly, a combustible feed
10 material 100 includes no more than about 5 ppmw iodine, more commonly no more than about 4 ppmw iodine, even more commonly no more than about 3 ppmw iodine, even more commonly no more than about 2 ppmw iodine and even more commonly no more than about 1 ppmw iodine (measured by neutron activation analysis ("NAA")). A combustible feed material 100 generally will produce, upon combustion, an unburned
15 carbon ("UBC") content of from about 0.1 to about 30% by weight and even more generally from about 0.5 to about 20% by weight.

 The feed material 100 is combusted in thermal unit 104 to produce a mercury-containing gas stream 108. The thermal unit 104 can be any combusting device, including, without limitation, a dry or wet bottom furnace (*e.g.*, a blast furnace, puddling
20 furnace, reverberatory furnace, Bessemer converter, open hearth furnace, basic oxygen furnace, cyclone furnace, stoker boiler, cupola furnace and other types of furnaces), boiler, incinerator (*e.g.*, moving grate, fixed grate, rotary-kiln, or fluidized or fixed bed, incinerators), calciners including multi-hearth, suspension or fluidized bed roasters, intermittent or continuous kiln (*e.g.*, ceramic kiln, intermittent or continuous wood-drying
25 kiln, anagama kiln, bottle kiln, rotary kiln, catenary arch kiln, Feller kiln, noborigama kiln, or top hat kiln), oven, or other heat generation units and reactors.

 The mercury-containing gas stream 108 includes not only elemental and/or speciated mercury but also a variety of other materials. A common mercury-containing gas stream 108 includes at least about 0.001 ppmw, even more commonly at least about
30 0.003 ppmw, and even more commonly from about 0.005 to about 0.02 ppmw mercury (both elemental and speciated). Other materials in the mercury-containing gas stream 108 can include, without limitation, particulates (such as fly ash), sulfur oxides, nitrogen oxides, carbon oxides, unburned carbon, and other types of particulates.

The temperature of the mercury-containing gas stream 108 varies depending on the type of thermal unit 104 employed. Commonly, the mercury-containing gas stream temperature is at least about 125°C, even more commonly is at least about 325°C, and even more commonly ranges from about 325 to about 500°C.

The mercury-containing gas stream 108 is optionally passed through the preheater 112 to transfer some of the thermal energy of the mercury-containing gas stream 108 to air input to the thermal unit 104. The heat transfer produces a common temperature drop in the mercury-containing gas stream 108 of from about 50 to about 300°C to produce a mercury-containing gas stream 116 temperature commonly ranging from about 100 to about 400°C.

The mercury-containing gas stream 116 is next subjected to particulate removal device 120 to remove most of the particulates from the mercury-containing gas stream and form a treated gas stream 124. The particulate removal device 120 can be any suitable device, including an electrostatic precipitator, particulate filter such as a baghouse, wet particulate scrubber, and other types of particulate removal devices.

The treated gas stream 124 is emitted, via gas discharge 128, into the environment. To control mercury emissions in the mercury-containing gas stream 108, an iodine-containing additive 132 is employed. The iodine in the additive 132 can be in the form of a solid, liquid, vapor, or a combination thereof. The iodine containing additive can comprise a vapor phase iodine, wherein at least 75% of the iodine-containing additive in the gas stream is the vapor phase iodine, at least 85% of the iodine-containing additive in the gas stream is the vapor phase iodine, and at least 95% of the iodine-containing additive in the gas stream is the vapor phase iodine. It can be in the form of elemental iodine (I₂), a halide (e.g., binary halides, oxo halides, hydroxo halides, and other complex halides), an inter-halogen cation or anion, iodic acid, periodic acid, periodates, a homoatomic polyanion, and mixtures thereof. In one formulation, the iodine in the additive 132 is composed primarily of an alkali or alkaline earth metal iodide. In one formulation, the iodine-containing additive 132 is substantially free of other halogens and even more typically contains no more than about 25%, even more typically no more than about 10%, and even more typically no more than about 5% of the halogens as halogen(s) other than iodine. In one formulation, the iodine-containing additive 132 contains at least about 100 ppmw, more commonly at least about 1,000 ppmw, and even more commonly at least about 1 wt.% iodine. In one formulation, the iodine-containing additive contains no more

than about 40 wt.% fixed or total carbon, more commonly no more than about 25 wt.% fixed or total carbon, even more commonly no more than about 15 wt.% fixed or total carbon, and even more commonly no more than about 5 wt.% fixed or total carbon. In one formulation, the iodine-containing additive 132 is a high (native) iodine coal. In one formulation, the iodine-containing additive 132 is an iodine-containing waste or byproduct material, such as a medical waste. In one formulation, the iodine-containing additive 132 comprises iodine attached to a solid support, such as by absorption, adsorption, ion exchange, formation of a chemical composition, precipitation, physical entrapment, or other attachment mechanism. The solid support can be inorganic or organic. Examples include ion exchange resins (functionalized porous or gel polymers), soil humus, a porous carbonaceous material, metal oxides (e.g., alumina, silica, silica-alumina, gamma-alumina, activated alumina, acidified alumina, and titania), metal oxides containing labile metal anions (such as aluminum oxychloride), non-oxide refractories (e.g., titanium nitride, silicon nitride, and silicon carbide), diatomaceous earth, mullite, porous polymeric materials, crystalline aluminosilicates such as zeolites (synthetic or naturally occurring), amorphous silica-alumina, minerals and clays (e.g., bentonite, smectite, kaolin, dolomite, montmorillinite, and their derivatives), porous ceramics metal silicate materials and minerals (e.g., one of the phosphate and oxide classes), ferric salts, and fibrous materials (including synthetic (for example, without limitation, polyolefins, polyesters, polyamides, polyacrylates, and combinations thereof) and natural (such as, without limitation, plant-based fibers, animal-based fibers, inorganic-based fibers, cellulosic, cotton, paper, glass and combinations thereof). Commonly, the halogen-containing additive 232 contains no more than about 10 wt.% iodine, more commonly no more than about 5 wt.% iodine, even more commonly no more than about 1 wt.% iodine, even more commonly no more than about 0.5 wt.% iodine, and even more commonly no more than about 0.1 wt.% iodine.

The iodine-containing additive 132 can be contacted with the mercury-containing gas stream at one or more contact points 136, 140, and 148 (where point 136 can be remote from the location of the thermal unit, including applying the additive to the feed at places such as a mine or in transit to the thermal unit location). At point 136, the iodine-containing additive 132 is added directly to the feed material 100 upstream of the thermal unit 104. At points 140 and 148, the iodine-containing additive 132 is introduced into the mercury-containing gas stream 108 or 116, such as by injection as a liquid, vapor, or solid powder. As can be seen from Fig. 1, the additive introduction can be done upstream or

downstream of the (optional) air preheater 112. The iodine-containing additive can be dissolved in a liquid, commonly aqueous, in the form of a vapor, in the form of an aerosol, or in the form of a solid or supported on a solid. In one formulation, the iodine-containing additive 132 is introduced as a liquid droplet or aerosol downstream of the thermal unit 104. In this formulation, the iodine is dissolved in a solvent that evaporates, leaving behind solid or liquid particles of the iodine-containing additive 132.

Surprisingly, the iodine-containing additive 132 can allow mercury capture without a carbon sorbent, native unburned carbon, or ash being present. In contrast to bromine, mercury removal by iodine does not primarily depend on co-injection of activated carbon sorbents for vapor-phase mercury capture. In one process configuration, the mercury-containing gas stream upstream of the particulate removal device is substantially free of activated carbon. The iodine-containing additive 132 can effectively enable or facilitate removal of at least about 40%, even more commonly at least about 75%, and even more commonly at least about 90% of the elemental and speciated mercury in the mercury-containing gas stream when the feed material 100, upon combustion, produces a UBC of no more than about 30% and even more commonly of no more than about 5%. When a higher UBC level is produced, the iodine-containing additive 132 can remove at least about 40%, even more commonly at least about 75%, and even more commonly at least about 90% of the elemental and speciated mercury in the mercury-containing gas stream that is not natively removed by the unburned carbon particles.

In one plant configuration, sufficient iodine-containing additive 132 is added to produce a gas-phase iodine concentration commonly of about 8 ppmw basis of the flue gas or less, even more commonly of about 5 ppmw basis or less, even more commonly of about 3.5 ppmw basis or less, even more commonly of about 1.5 ppmw or less, and even more commonly of about 0.4 ppmw or less of the mercury-containing gas stream. Stated another way, the iodine concentration relative to the weight of mercury-containing, combustible (e.g., coal) feed (as fed) (whether by direct application to the combustible feed and/or injection into the mercury-containing (e.g., flue) gas) commonly is about 40 ppmw or less, more commonly about 35 ppmw or less, even more commonly about 30 ppmw or less, even more commonly is about 15 ppmw or less, even more commonly no more than about 10ppmw, even more commonly no more than about 6 ppmw, even more commonly about 4 ppmw or less, and even more commonly no more than about 3 ppmw. Stated another way, the molar ratio, in the mercury-containing (e.g., flue) gas, of gas-phase

diatomic iodine to total gas-phase mercury (both speciated and elemental) is commonly no more than about 1,200, and even more commonly no more than about 600, even more commonly no more than about 250, even more commonly no more than about 150, and even more commonly no more than about 80. By way of illustration, an effective concentration of gas-phase iodine at the air preheater outlet or particulate removal device inlet ranges from about 0.1 to about 10 ppmw, even more commonly from about 0.15 to about 5 ppmw, even more commonly from about 0.20 to about 2 ppmw, and even more commonly from about 0.25 to about 1.50 ppmw of the mercury-containing gas stream.

Commonly, the mercury-containing gas stream includes no more than about 1.0, even more commonly no more than about 0.5 and even more commonly no more than about 0.1 ppmw total bromine. The feed material generally includes no more than about 10 ppmw and even more commonly no more than about 5 ppmw natively occurring bromine.

The mercury-containing (e.g., flue) gas temperature for elemental mercury capture promoted by iodine commonly ranges from about 150 to about 600°C and even more commonly from about 180 to about 450°C. The residence time upstream of particulate (e.g., fly ash) removal device 120 is commonly about 8 seconds, and even more commonly at least about 4 seconds, and even more commonly at least about 2 seconds.

Generally, sufficient iodine-containing additive 132 is added to produce a gas-phase iodine concentration commonly of about 3.5 ppmw or less, even more commonly of about 2 ppmw or less, even more commonly of about 1.5 ppmw or less, and even more commonly of about 0.4 ppmw or less. Stated another way, the molar ratio, in the mercury-containing (e.g., flue) gas, of gas-phase iodine to total gas-phase mercury (both speciated and elemental) is commonly no more than about 1,000, even more commonly no more than about 600, even more commonly no more than about 500, even more commonly no more than about 250, even more commonly no more than about 150, and even more commonly no more than about 80.

The above concentration ranges and conditions can, in appropriate applications, apply to bromine as a mercury removal additive.

Mercury Removal by Halogen-Containing Additive in Presence of Selective Catalytic Reduction

In another plant configuration shown in Fig. 2, the halogen concentration needed to effect mercury removal is further reduced by coupling halogen with a selective catalytic

reduction ("SCR") zone prior to particulate removal. As will be appreciated, SCR converts nitrogen oxides, or NO_x , with the aid of a catalyst, into diatomic nitrogen (N_2) and water. A gaseous reductant, typically anhydrous ammonia, aqueous ammonia, or urea (but other gas-phase reductants may be employed), can be injected into a stream of flue or exhaust gas or other type of gas stream or absorbed onto a catalyst followed by off gassing of the ammonia into the gas stream. Suitable catalysts include, without limitation, ceramic materials used as a carrier, such as titanium oxide, and active catalytic components, such as oxides of base metals (such as vanadium (V_2O_5), wolfram (WO_3), titanium oxide (TiO_2) and tungstate (e.g., WO_4^{2-}), zeolites, and various precious metals. Other catalysts, however, may be used.

The SCR catalyst surface, depending on the design, catalyst and layering, is active for reactions other than the primary nitrogen oxide reduction. There are competing reactions occurring for available sites to reduce NO_x , oxidize SO_2 to SO_3 and to promote the reaction of mercury with various species to result in an increased fraction of oxidized mercury species. The SCR ammonia rate is co-variable with load and temperature and affects the balance between these competing reactions.

The presence of ultra trace vapor iodine and/or bromine species at the SCR catalyst surface can be surprisingly effective for mercury control. While not wishing to be bound by any theory, the amount of halogen (e.g., iodine and/or bromine) required to result in the formation of an oxidized form of mercury is lower when an SCR is in use. The surface of the SCR catalyst is believed to promote the formation of diatomic elemental halogens and/or mercury oxidation.

To capture the oxidized mercury in the particulate collection device, vapor SO_3 in the flue gas should be managed to limit the concentration after the air preheater. This can be accomplished by selection of lower-sulfur and higher alkaline coal, selection of lower activity SCR catalyst and control of SCR reagent injection rate and temperature. These interactive parameters must be managed to achieve the desired de NO_x rate.

In one configuration, combustion of high alkali coals and low-sulfur coals is preferred to further inhibit formation of vapor SO_3 species. The SCR catalyst is typically selected to yield a specified SO_2 to SO_3 conversion rate for a design coal and operating condition. Catalyst activity gradually degrades over a period of years and must be replaced. A number of catalytic layers installed at intervals, with different oxidation rates, ages and catalyst activity are typically present for coal-fired plant SCRs. Effective SO_2 to

SO₃ oxidation rate across the aggregate of catalyst surfaces in an SCR should be preferably lower than about 2.0% and more preferably lower than about 1.5% and even more preferably lower than about 1.2% in order to limit vapor SO₃ formation in the SCR.

Vapor SO₃ can also be controlled after formation in the SCR by means of in-duct injection of sorbents or by absorption in a dry scrubber. Vapor SO₃ can also be condensed on intermediate surfaces prior to the particulate control device, in particular the air preheater. Lower process temperatures will reduce SCR oxidation rate and increase SO₃ dropout in the air preheater. Mercury oxidation in the SCR benefits when SO₃ is reduced as a competing reaction, even at lower temperatures.

Ammonia reacts within the SCR to reduce nitrogen oxides. Excess ammonia lowers the ability of the SCR to react with or catalyze reaction (oxidation) of mercury. In one configuration, concentration(s) of ammonia and precursors thereof are maintained at a level just sufficient for deNO_x. That is, the concentration of ammonia and precursors thereof is preferably no more than about 125%, more preferably no more than about 120%, more preferably no more than about 115%, and even more preferably no more than about 110% of the stoichiometric amount required to perform deNO_x. As a result, the amount of ammonia slip will be reduced relative to conventional SCR-based systems. SCR reagent rate and/or ammonia and precursor addition is controlled to yield an average flue gas ammonia slip immediately downstream of the SCR of preferably less than about 5 ppmv and more preferably less than about 3 ppmv as ammonia.

To realize the full benefits of mercury oxidation by low concentration halogen addition with SCR and further achieve substantial removal of mercury in the particulate control device, the vapor SO₃ in the flue gas at the particulate control device inlet is commonly limited to less than about 7.5 ppm_v, more commonly to less than about 5 ppm_v and more preferably to less than 2 ppm_v at all process conditions by the methods described above, singly or in combination.

In one configuration, the halogen/mercury mass ratio for iodine as the primary halogen additive is commonly no more than about 200, more commonly no more than about 100, more commonly no more than about 75, more commonly no more than about 50, and more commonly no more than about 40 and commonly at least about 5, more commonly at least about 10, more commonly at least about 15, and even more commonly at least about 20.

In one configuration, the halogen/mercury mass ratio for bromine as the primary halogen additive is commonly no more than about 400, more commonly no more than about 300, more commonly no more than about 275, more commonly no more than about 250, and more commonly no more than about 240 and commonly at least about 10, more commonly at least about 20, more commonly at least about 30, and even more commonly at least about 40.

In one configuration, the maximum amount of halogen added to the feed material 100 is commonly no more than about 40 ppmw, more commonly no more than about 25 ppmw, more commonly no more than about 20 ppmw, more commonly no more than about 15 ppmw, and even more commonly no more than about 10 ppmw, and the minimum amount of halogen added to the feed material 100 is commonly at least about 0.5 ppmw, more commonly at least about 0.75 ppmw, more commonly at least about 1 ppmw, and even more commonly at least about 1.5 ppmw.

The embodiment is directed particularly to the capture of mercury from systems with conventional SCR firing low sulfur and halogen-deficient coals (e.g., coals having no more than about 6 ppmw bromine and/or iodine). The embodiment can enhance mercury capture on the particulate control device and not on any wet flue gas desulfurization (FGD) scrubber. Low concentration iodine, in particular, surprisingly achieves mercury oxidation with SCR, and the oxidized mercury can be captured in the particulate-phase on the fly ash surface, particularly when the sulfur trioxide concentration in the flue gas at the particulate control device is managed to an amount of less than about 2 ppmv. This embodiment can be used with currently installed SCR catalysts for low sulfur, low halogen fueled units. In addition, though for bituminous coals there is ample native chlorine and bromine to oxidize mercury to as high as 100% across the SCR, the SCR is generally unable to realize any mercury capture until the FGD scrubber (due to the vapor SO_3). Iodine-oxidized mercury species are typically not effectively captured in an FGD scrubber because iodine-Hg species are generally not soluble. Accordingly, the present embodiment captures mercury (for lower SO_3 concentrations) at the ESP or baghouse.

Referring to Fig. 2, the waste stream 108 optionally flows through an economizer 200, which transfers some of the heat of the combustion stream 108 to water for recycle to other operations. The halogen-containing additive 232 is contacted with the feed material 100 upstream of the thermal unit 104 and/or with the mercury-containing gas stream 108 inside or downstream of the thermal unit 104.

The mercury-containing gas stream 108 proceeds to SCR unit 204, where nitrogen oxides are converted into molecular nitrogen and water.

The mercury-containing gas stream 108 proceeds to the optional air preheater 112 and then is subjected to particulate removal by particulate removal device 120 to form a treated gas stream 124 that is substantially free of particulates and mercury. As will be appreciated, an economizer uses waste heat by transferring heat from flue gases to warm incoming feedwater (e.g., which is subsequently converted into steam for power generation) while a preheater is a heat exchanger that transfers thermal energy from flue gas to combustion air before input of the combustion air to the furnace.

The treated gas stream 124 is then emitted from the gas discharge 128.

Although the SCR catalyst is commonly located between the economizer and air preheater outlet, it may be located at other locations in the mercury-containing gas stream. The SCR catalyst is commonly located prior to (or upstream of) the particulate removal device (e.g. baghouse and electrostatic precipitator). Commonly, SCR catalysis is performed at a temperature ranging from about 250 to about 500°C, more commonly at a temperature ranging from about 300 to about 450°C, and even more commonly at a temperature ranging from about 325 to about 400°C. The degree of SO₂ to SO₃ oxidation by the SCR varies within this temperature range depending on plant load, catalyst characteristics and other process conditions. At lower temperatures, the SCR contribution to total vapor SO₃ can be negligible.

Removal of Mercury by Halogen-Containing Additive and Mercury Active Agent

In another configuration, a combination of iodine or bromine on the one hand with another mercury active agent on the other is utilized to effect mercury oxidation and removal, particularly at higher temperatures than is possible with bromine or chlorine or hydrogen chloride alone. As used herein, a "mercury active agent" refers to an additive that oxidizes elemental mercury and/or catalyzes the formation of diatomic halogens. Conversion of elemental mercury to oxidized species is typically accomplished by the combined halogens that are either present in or added to the combustible fuel.

In one plant design, additional halogens, preferably in the form of diatomic elemental halogens, are, in addition to those in the combustible fuel, injected post-combustion.

In another plant design, oxidants, such as other halogens or non-halogen mercury active agents, are added to the combustible fuel in addition to or in lieu of downstream flue gas introduction.

Examples of suitable mercury active agents that are oxidants, which are combined with iodine or bromine prior to fuel pre-combustion include bromide salts including sodium, calcium, magnesium, zinc or potassium bromide, calcium, sodium or potassium bromate, iodide salts including sodium, calcium, magnesium, zinc or potassium iodide, calcium, sodium or potassium iodate, chloride salts including sodium, calcium, magnesium, zinc or potassium chloride, calcium, sodium or potassium chlorate, sodium, iron oxides sufficient to enrich the fly ash, and diatomic bromine or chlorine sorbed onto a suitable sorbent.

Examples of additional mercury active agents that are oxidants added to the feed material pre- or to the waste gas post-combustion in combination with iodine or bromine added to the feed material include bromine, iodine, or chlorine gas (preferably as diatomic elemental halogens), hydrogen bromide, hydrogen chloride, chlorite, chlorate, perchlorate, hypochlorite, and other bromine, chlorine and fluorine-containing compounds, finely divided iron oxides, copper oxides and other base metal oxides.

As will be appreciated, other mercury active agents can be employed. For example, different mercury active agents, that perform differing of the functions of oxidizing elemental mercury and/or catalyzing the formation of diatomic halogens, can be blended, mixed or otherwise combined or co-injected. For example, mercury oxidants can be added upstream, in, or downstream of the SCR zone. In one formulation, a first mercury active agent, such as an SCR catalyst, can catalyze the formation of diatomic halogens, a second mercury active agent, such as a halogen-containing compound or metal oxide, can oxidize elemental mercury and a reactive surface agent, such as circulating fluidized bed ash, powdered zeolites, fluidized catalytic cracker (FCC) fines, fumed silicates, metal oxide particles or powders, such as iron oxide, re-milled or fine fraction fly ash, fluidized bed combustor ash and combinations thereof, provides surface area for removal of mercury compounds.

While not wishing to be bound by any theory, it is believed that the halogen in the form of diatomic halogen gas is both an efficient mercury oxidizer and is available for reaction with oxidized mercury by direct halogenation to form, for example, HgI_2 or HgBr_2 . In this configuration, the iodine (or iodine and bromine or bromine) concentration

needed to effect mercury oxidation and mercury halogenation is reduced by addition of an oxidant to the flue or waste gas.

The mercury active agent and halogen are believed to act synergistically to effect mercury oxidation for subsequent removal by fly ash, unburned carbon, or another suitable additive. The mercury active agent can be supported or unsupported, with preferred carriers being a porous carbonaceous substrate (such as fly or bottom ash from coal combustion, carbon black, activated carbon, coke, char, charcoal, and the like), activated alumina, ceramic, clay, silica, silica-alumina, silicates, zeolites, fine fraction fly ash, bottom ash, FCC fines, fluidized bed combustor ash, and the like. The mercury active agent can be introduced either as a liquid, such as a slurry in a vaporizable carrier liquid or dissolved in a solvent, as particles or powders, as a gas, or as a combination thereof.

In either of the above plant configurations, the mercury oxidation, whether by unburned carbon or mercury active agent addition, is performed preferably between the economizer and air preheater outlet or at a preferred temperature of from about 250 to about 500°C, a more preferred temperature of from about 300 to about 450°C, and an even more preferred temperature of from about 325 to about 400°C.

In one application, iodine and/or bromine is added to the combustible fuel or otherwise introduced to the furnace or boiler, such as in levels set forth above, while a diatomic elemental halogen (such as diatomic elemental iodine, bromine, and/or chlorine) is added to the flue gas downstream from the furnace or boiler. In this configuration, the flue gas concentration of the injected or otherwise introduced diatomic elemental halogen preferably ranges from about 0.1 to about 8 ppm_w of the flue gas, even more preferably from about 0.25 to about 5 ppm_w, and even more preferably from about 0.5 to about 2 ppm_w.

In one application, iodine and/or bromine are added to the combustible fuel or otherwise introduced to the furnace or boiler while a non-halogen oxidant, such as those set forth above, is added to the flue gas downstream from the furnace or boiler. In this configuration, the flue gas concentration of the injected or otherwise introduced oxidant preferably ranges from about 0.1 to about 8 ppm_w, even more preferably from about 0.25 to about 5 ppm_w, and even more preferably from about 0.5 to about 2 ppm_w.

In either application, the halogen or non-halogen oxidant or mixture thereof is typically introduced either as a gas or a liquid droplet or aerosol, with the oxidant being dissolved in a vaporizable solvent.

In one application, halide or interhalogen compound-containing additive 132 is added to the feed material 100 or otherwise introduced to the thermal unit 104 while diatomic elemental iodine (I₂) or bromine (Br₂) is added to the flue gas downstream from the thermal unit 104. In this configuration, the flue gas concentration of the injected or otherwise introduced diatomic iodine commonly ranges from about 0.1 to about 8 ppmw, even more commonly from about 0.25 to about 5 ppmw, and even more commonly from about 0.5 to about 2 ppmw of the mercury-containing gas stream.

Figs. 8-9 provide an example of a plant configuration according to an embodiment.

The mercury active agent 900 is introduced to the feed material 100, in the thermal unit 104, at a point 140 between the thermal unit 104 and optional preheater 112 and/or at a point 148 between the optional preheater 112 and a particulate removal device 120 or between the optional preheater 112 (Fig. 8) and a scrubber 400 (Fig. 9). When the mercury active agent 900 is introduced upstream of the preheater 112, the mercury active agent 900 is typically a non-carbonaceous agent due to the high mercury-containing gas stream temperature.

The mercury-containing gas stream 116 is thereafter treated by the particulate removal device 120 (Fig. 8) and/or by the dry scrubber 400 and particulate removal device 120 (Fig. 9) to form a treated gas stream. The dry scrubber 400 injects a dry reagent or slurry into the mercury-containing gas stream 116 to "wash out" acid gases (such as SO₂ and HCl). A dry or semi-dry scrubbing system, unlike a wet scrubber, does not saturate the flue gas stream that is being treated with moisture. In some cases, no moisture is added. In other cases, only the amount of moisture that can be evaporated in the flue gas without condensing is added.

Although the scrubber 400 is shown after the preheater 112, it is to be understood that the scrubber 400 may be located at several different locations, including without limitation in the thermal unit 104 or in the gas stream duct (at a point upstream of the particulate control device 120 such as at points 140 and/or 148) (as shown in Fig. 9).

The particulate control device 120 removes substantially all and typically at least about 90% of the particles entrained in the mercury-containing gas stream 116. As a result, at least most of the iodine and mercury in the mercury-containing gas stream 116 is removed by the particle removal device 120.

Removal of Mercury by Halogen-Containing Additive and Reactive Surface Agent Addition

Although additional reactive surface particles are normally not required for iodine to form a mercury-containing particulate, in other embodiments addition of carbon- and non-carbon-containing solid and/or aerosol particles, referred to as "reactive surface agents", in favorable regions of the flue gas stream can enhance mercury removal by the iodine-containing additive 132, particularly when the feed material 100 produces, upon combustion, a low UBC level or the mercury-containing gas stream 108 has low levels of natively occurring particulates, such as ash, unburned carbon, soot, and other types of particulates. Low UBC levels generally comprise no more than about 30, even more generally no more than about 5, and even more generally no more than about 0.5% UBC in the post-combustion particulate. In one configuration, the surface active agent acts as a support for iodine or bromine, as discussed above.

While not wishing to be bound by any theory, it is believed that reactive surface agents provide surface area that iodine, mercury, and/or mercuric iodide or bromide can chemically react with (e.g., provides surface area for heterogeneous mercury reactions) and/or otherwise attach to. The reactive surface agent can be any carbon- or non-carbon-containing particle that provides a nucleation or reaction site for iodine, bromide, mercury, mercuric iodide, and/or mercuric bromide. Suitable solid or liquid reactive surface agents 300 include, without limitation, zeolites, silica, silica alumina, alumina, gamma-alumina, activated alumina, acidified alumina, amorphous or crystalline aluminosilicates, amorphous silica alumina, ion exchange resins, clays (such as bentonite), a transition metal sulfate, porous ceramics, porous carbonaceous materials, such as coal ash (e.g., fly or bottom ash), unburned carbon, charcoal, char, coke, carbon black, activated carbon, other hydrocarbon and coal derivatives, and other forms of carbon, trona, alkali metal bicarbonates, alkali metal bisulfates, alkali metal bisulfites, alkali metal sulfides, elemental sulfur, limestone, hydrated or slaked lime, circulating fluidized bed ash, fluidized catalytic cracker (FCC) fines, fumed silicates, metal oxide particles or powders, such as iron oxide and those comprising labile anions, re-milled or fine fraction fly ash, bottom ash, fluidized bed combustor ash, and mixtures thereof. The reactive surface agent 300 may be introduced as a solid particle (powder) and/or as a dissolved or slurried liquid composition comprising a vaporizable liquid carrier.

The mean, median, and P₉₀ sizes of the particles are typically no more than about 100 microns, even more typically no more than about 50 microns, even more typically no more than about 25 microns, even more typically no more than about 10 microns, and even more typically no more than about 5 microns. Unlike iodine additives, micron-sized non-carbon particles have not been consistently effective with bromine or chlorine-based coal additives.

In some configurations, the reactive surface agent is a porous carbonaceous or non-carbonaceous material, such as coke, fly ash, bottom ash, pet coke, carbon black, activated carbon, charcoal, char, beneficiated unburned carbon derived from fly ash, and mixtures thereof. In some applications, the porous carbonaceous or non-carbonaceous material is powdered and typically has a P₈₅ size of no more than about 1 mm in size and more typically of no more than about 0.75 mm in size and an average diameter typically between about 0.10 to about 0.75 and more typically between about 0.15 to about 0.25 mm. In some applications, the porous carbonaceous or non-carbonaceous material is granular and typically has a P₈₅ size of more than about 1 mm in size and more typically of in the range of from about 1 mm to about 2.5 mm in size and an average diameter typically between about 0.75 to about 1.25 mm.

The porous carbonaceous or non-carbonaceous material may be impregnated with a chemical agent, such as a mercury active agent. Porous carbonaceous or non-carbonaceous materials can contain a variety of inorganic impregnants, such as ionic, elemental, or compounded halogens (e.g., iodine, iodide, bromine, bromide, chlorine, chloride, iodine-containing salts, bromine-containing salts, chlorine-containing salts, and mixtures thereof) silver, and cations such as alkali earth metals, alkaline earth metals, and transition metals. In one formulation, the porous carbonaceous or non-carbonaceous material is impregnated with a mercury active agent or SCR catalytic material.

The amount of chemical agent in the porous carbonaceous or non-carbonaceous material can vary widely. Commonly, the impregnated porous carbonaceous or non-carbonaceous material comprises at least about 0.1 wt.%, more commonly at least about 0.5 wt.%, and even more commonly at least about 1 wt.% chemical agent and no more than about 5 wt.%, more commonly no more than about 4 wt.%, and even more commonly no more than about 2 wt.% chemical agent.

The porous carbonaceous material or non-carbonaceous can have a high surface area. Typically, the porous carbonaceous or non-carbonaceous material has a surface area of at least about 500 m²/g, more typically of at least about 750 m²/g, and even more typically of at least about 1,000 m²/g and no more than about 2,500 m²/g, more typically no more than about 2,000 m²/g, and even more typically no more than about 1,500 m²/g.

The ash content of the porous carbonaceous or non-carbonaceous material can determine the efficiency of reactivation. The porous carbonaceous or non-carbonaceous material typically has an ash content in the range of from about 10% to about 95% and even more typically in the range of from about 20% to about 70%.

Commonly, the reactive surface agent is introduced downstream of the iodine-containing additive 132, more commonly downstream of the economizer 200, and more commonly downstream of the air preheater 112 and upstream of particulate removal device 120 and/or scrubber 400.

In other embodiments, the additive 132 is combined with other pollution control technologies that provide suspended solid and/or aerosol particles or other reaction surfaces at favorable location and temperature. Exemplary embodiments include, without limitation:

1. Spraying slurried solids or solutions of dissolved solids at a point upstream to allow sufficient evaporation. In a utility boiler, this region would normally be prior to, or upstream of, any air preheater 112 to allow sufficient residence time.
2. Providing a downstream slurry spray such as by conventional flue gas desulfurization ("FGD") spray dryer absorber ("SDA"). The slurry spray would normally be downstream of any air preheater 112.
3. Providing alkaline liquid spray, such as wet FGD, to capture residual mercury past the ESP rather than allowing re-emission of mercury as elemental mercury - as can happen with bromine or chlorine.
4. Providing intimate particulate contact for the iodine-mercury or bromine-mercury compounds, such as filtering the flue gas through a fabric filter.
5. Providing additional submicron aerosol at the inlet to an air preheater 112 to take advantage of the temperature differential across the air preheater to boost surface reaction.

Examples of these alternatives will be discussed with reference to Figs. 3-6 and 8.

Referring to the embodiments of Figs. 3 and 4, the reactive surface agent 300 is introduced at a point 140 between the thermal unit 104 and optional preheater 112 and/or at a point 148 between the optional preheater 112 and a particulate removal device 120 (Fig. 3) or between the optional preheater 112 and a scrubber 400 (Fig. 4). When the reactive surface agent 300 is introduced upstream of the preheater 112 and vapor phase halogens are present in the gas stream, the reactive surface agent 300 is believed to increase the maximum temperature where mercury removal begins and increase the overall mercury removal effectiveness.

The mercury-containing gas stream 116 is thereafter treated by the particulate removal device 120 (Fig. 3) and/or by the dry scrubber 400 and particulate removal device 120 (Fig. 4) to form a treated gas stream.

Although the scrubber 400 is shown after the preheater 112, it is to be understood that the scrubber 400 may be located at several different locations, including without limitation in the thermal unit 104 or in the gas stream duct (at a point upstream of the particulate control device 120 such as at points 140 and/or 148) (as shown in Fig. 4).

The particulate control device 120 removes substantially all and typically at least about 90% of the particles entrained in the mercury-containing gas stream 116. As a result, at least most of the iodine and mercury in the mercury-containing gas stream 116 is removed by the particle removal device 120.

In another embodiment shown in Fig. 6, the reactive surface agent 300 is introduced at one or more points 140, 148, and/or 600 to the mercury-containing gas stream. The mercury-containing gas stream treatment process includes first and second particulate removal devices 120A and B positioned on either side or on a common side (e.g., downstream) of the preheater 112. Due to the higher reaction/condensation temperature of iodine compared to bromine, the halogen-containing additive 232 can be introduced to the feed material 100, in the thermal unit 104, between the thermal unit 104 and first particulate removal device 120A and/or between the first and second particulate removal devices 120A and B to enable or facilitate removal of a first portion of the evolved elemental and speciated mercury in the mercury-containing gas stream 108. The reactive surface agent 300 may optionally be introduced between the first and second particulate removal devices 120A and B to enable or facilitate removal of additional elemental and speciated mercury in the second particulate removal device 120B. The first portion represents typically at least most of the mercury in the mercury-containing gas stream 108

upstream of the first particulate removal device 120. In one configuration, the reactive surface agent 300 is typically a non-carbon agent due to the high mercury-containing gas stream temperature upstream of the preheater 112.

Fig. 5 shows a mercury-containing gas stream treatment system according to another embodiment.

The treated gas stream 504 is further treated by a scrubber 500 prior to discharge by gas discharge 126 to remove speciated mercury compounds, not removed by the particulate removal device 120, and sulfur oxides. The scrubber 500 is typically a wet scrubber or flue gas desulfurization scrubber. Wet scrubbing works via the contact of target compounds or particulate matter with the scrubbing solution. The scrubbing solution comprises reagents that specifically target certain compounds, such as acid gases. A typical scrubbing solution is an alkaline slurry of limestone or slaked lime as sorbents. Sulfur oxides react with the sorbent commonly to form calcium sulfite and calcium sulfate.

The scrubber 500 has a lower dissolved mercury and/or halogen concentration than conventional treatment systems, leading to less corrosion and water quality issues. Although mercury vapor in its elemental form, Hg^0 , is substantially insoluble in the scrubber, many forms of speciated mercury and halogens are soluble in the scrubber. Diatomic iodine, however, has a very low solubility in water (0.006g/100 ml), which is significantly different from (less soluble than) Cl_2 and Br_2 .

Because mercuric iodide is significantly less soluble than mercuric chloride or bromide and because a greater fraction of mercury is removed by particulate removal devices (e.g. baghouse and electrostatic precipitator) prior to the wet scrubber, soluble mercury present in the scrubber slurry will be reduced. As will be appreciated, mercuric chloride and bromide and diatomic chlorine and chloride, due to their high solubilities, will typically build up in the scrubber sludge to high levels, thereby requiring the scrubber liquid to be periodically treated. In addition, mercury contamination of by-product FGD gypsum board is a problem that this disclosure also addresses by reducing mercury present in scrubber slurry.

In some applications, the total dissolved mercury concentration in the scrubber is relatively low, thereby simplifying treatment of the scrubber solution and reducing mercury contamination of by-product materials. Typically, no more than about 20%, even more typically no more than about 10%, and even more typically no more than about 5%

of the total mercury in the mercury-containing gas stream is dissolved in the scrubber solution.

As set forth below, test data show that the iodine is surprisingly and unexpectedly effective compared to what was previously thought achievable from injection of halogens including, bromine or chlorine. Whereas other halogens, such as bromine, generally require additive rates between 30 and 100ppmw of feed material 100, iodine appears to be at least 10 times more effective. Applicant has measured 70 to 90% mercury capture with just 3 ppmw iodine in the feed material.

A further plant configuration is shown in Fig. 10.

A combustible feed material 100 and halogen-containing additive 232 (which may be formed by the process above) are combusted in the thermal unit 104 to produce the mercury-containing gas stream 108. The mercury-containing gas stream 108 is treated by optional (hot-side) particulate removal device 120 to remove at least most of any particulate material in the mercury-containing gas stream 108 and produce a (treated) mercury-containing gas stream 116. The mercury-containing gas stream 116 is passed through optional preheater 112 to produce a cooled gas stream 804. The cooled gas stream 804 is subjected to optional (cold-side) particulate removal device 120 to remove at least most of any particulates in the cooled gas stream 804 and form the treated gas stream 124.

Porous carbonaceous or non-carbonaceous material 800 is introduced, typically by injection, into the mercury-containing gas stream 108 at one or more contact points 140, 148, and 600. The porous carbonaceous or non-carbonaceous material 800 collects gaseous contaminants, including oxidized mercury, speciated mercury, acid gases, and halogens and halides, prior to be removed by the optional particulate removal device 120 and/or 120.

The porous carbonaceous or non-carbonaceous material 800 can be entrained in a carrier gas or in the form of a slurry when introduced, under pressure, into the gas stream. The rate of addition of the porous carbonaceous or non-carbonaceous material 800 to the gas stream typically is in the range of from about 6 to about 0.1, more typically in the range of from about 4 to about 0.25, and even more typically in the range of from about 2 to about 0.5 lb material/MMacf gas.

EXPERIMENTAL

The following examples are provided to illustrate certain embodiments of the invention and are not to be construed as limitations on the invention, as set forth in the appended claims. All parts and percentages are by weight unless otherwise specified.

Experiment 1

A trial of mercury control by addition of coal additives was completed on a cyclone-fired boiler rated at 280 MW gross electricity production, but capable of short-term peak production of 300 MW. The boiler configuration was six cyclone combustors arranged three over three on the front wall. Each cyclone burns approximately 54,000 lb/h of Powder River Basin (PRB) coal at full load. The typical coal sulfur content is 0.3% (dry basis) and the coal ash calcium expressed as CaO (dry basis) averages 20%.

NO_x emissions are controlled on this Unit by Overfire Air (OFA) ports located on the rear wall, and by a Selective Catalytic Reduction (SCR) system located upstream of the air preheater. There are no mercury controls on this boiler, but a portion of the mercury released during combustion is retained by unburned carbon particles captured in the electrostatic precipitator.

A liquid-phase iodine-containing additive, that was substantially free of bromine and chlorine, and a solid-phase iron-containing additive were added to the furnace. While not wishing to be bound by any theory, the iodine-containing additive is believed to control Hg emissions by enhancing the amount of particle-bound mercury captured. The iron-containing additive is believed to thicken the molten slag layer contained in the cyclone so that more combustion occurred in the fuel-rich region. Increasing the fuel-rich combustion leads to lower NO_x emissions in the flue gas leaving the boiler. The iodine-containing additive contained from about 40 to about 50 wt.% iodine. The iron-containing additive contained from about 60 to about 70 wt.% total iron, of which from about 30 to about 70 wt.% was ferrous oxide (FeO), and the remaining portion was substantially all either ferrous ferric oxide (magnetite, Fe₃O₄), ferric oxide (Fe₂O₃), or a mixture thereof. Enrichment of the fly ash with reactive iron may function as a catalyst for heterogeneous mercury oxidation.

Depending on access and/or coal yard operational procedures, the additives were applied to the coal either upstream or downstream of the crusher house. The solid-phase

iron-containing additive was provided in granular form that was stored in a bulk storage pile located in close proximity to the iron-containing additive conveying equipment. The iron-containing additive was transferred from the storage pile to a feed hopper via front-end loader and added to the coal belt via a series of screw feeders and bucket elevators.

The liquid iodine-containing additive was delivered in Intermediate Bulk Container (IBC) totes. The liquid material was metered by a chemical pump to a dispensing nozzle at the top of the bucket elevator where it was combined with the iron-containing additive prior to being dropped onto the coal supply belt. The feed rate of both the solid iron-containing additive and the liquid iodine-containing additive was controlled to an adjustable set-point based on the weight of coal being fed on the coal belt. The hopper of the conveyor was filled several times a day during normal operations.

This goal of this trial was to demonstrate 20 percent NO_x reduction and 40 percent mercury reduction over a three-hour period at full load. The test period included several days of operation with and without additive coal treatment. The initial test period was deemed the "Baseline Tests" conducted to quantify the native or untreated Hg emissions in the stack and the baseline NO_x emissions. Then, additive treatment using both additives began, and combustion improvements were confirmed by measuring higher cyclone temperatures with an infrared pyrometer. After a few days of operation with both additives, the expected NO_x reduction was recorded during a one-day combustion tuning test designed to demonstrate that the iron-containing additive would allow more aggressive cyclone operation than was previously possible. Boiler performance was monitored carefully during the emissions test to assure that the emission reductions did not cause other problems. Hg reduction was demonstrated using data from a Thermo Fisher Mercury CEM on the stack (downstream from the ESP) and further validated using a modified EPA Method 30-B, "*Determination of Mercury from Coal-Fired Combustion Sources Using Carbon Sorbent Traps*", the Sorbent Trap Method (STM). Finally, the unit was operated for several days in load dispatch mode to demonstrate the long term operability of the treated fuel.

Based on historical coal analyses, the uncontrolled Hg emissions without the iodine-containing additive were expected to vary between 5 and 10 µg/wscm (0.004 to 0.008 ppmw total Hg in flue gas). Uncontrolled emissions calculated from average coal mercury analysis were 6 µg/wscm (0.005 ppmw) at the air preheater outlet. However, due to the high amount of unburned carbon in the fly ash (10-20%) and low flue gas

temperatures (< 300°F), there was significant native mercury removal without the iodine-containing additive. During the test period, baseline Hg concentrations as measured at the outlet continuous emission monitor ("CEM") ranged from 1.0 to 1.5 µg/wscm (0.0008 to 0.0013 ppmw).

Prior to iodine-containing additive addition, the total Hg emission averaged about 1.1 µg/wscm (0.0009 ppmw). After this baseline period, both the iron- and iodine-containing additives were added to the coal at various concentrations. The iron-containing additive was added at between about 0.3% and 0.45% by weight of the coal feed. The iodine-containing additive was added at a rate ranging from about 2 to 7 ppmw of the operative chemical to the mass feed rate of the coal. Hg emissions measured at the stack dropped to the range of 0.1 to 0.4 µg/wscm (0.0001 to 0.0003 ppmw). Therefore, Hg reduction ranged from about 60 to 90 percent additional removal compared to the baseline removal with just the high-UBC fly ash, with an average of 73 percent additional reduction when the additive rate was optimized. Overall mercury removal based on the uncontrolled mercury concentration from coal mercury was more than 95%. Table 1 summarizes the results achieved at each iodine treatment rate.

The STM results confirmed the Hg-CEM results. Three pairs of baseline mercury ("Hg") samples were obtained. The Hg concentrations ranged from about 1.1 to 1.6 µg/wscm (0.0009 to 0.0013 ppmw), with an average of 1.36 µg/wscm (0.0011 ppmw). Three pairs of sorbent traps were also pulled during iodine-containing additive use. These Hg values ranged from about 0.3 to 0.4 µg/wscm (0.0002 to 0.0003 ppmw), with an average of 0.36 µg/wscm (0.00026 ppmw). The average Hg reduction, compared to baseline mercury removal, as determined by the STM Method, was 73 percent, exactly the same as the additional Hg reduction determined by the Hg-CEM.

Even though the electrostatic precipitator was already removing about 71 percent of the Hg without iodine addition, treatment with the iodine-containing additive caused removal of an additional 73 percent of the Hg. With iodine addition, the total Hg removal based on the Hg content of the coal was 96 percent with a treatment rate of 7 ppmw iodine to the feed coal. Surprisingly, with a treatment of just 2 ppmw iodine and added iodine/mercury molar ratio of only 30, the total mercury removal was 90%.

Table 1: Experiment 1, Results with SCR^{1,2}

Iodine Addition to Coal (ppmw)	Added Iodine/Hg Molar Ratio	Uncontrolled Mercury ($\mu\text{g/wscm}$) ¹	Controlled Mercury ($\mu\text{g/wscm}$)	Mercury Removal above Baseline (%)	Total Mercury Removal (%)
0	0	4.0	1.1	0%	71%
7	106	4.0	0.15	86%	96%
5	75	4.0	0.2	82%	95%
3	45	4.0	0.3	73%	93%
2	30	4.0	0.4	64%	90%

¹. Average uncontrolled mercury concentration based on average coal analysis of 72 ng/g at full load coal rate and APH outlet gas flow.

². Unit load was 280 MW or more for all of the tests with gas temperature at the APH outlet ranging from about 285 to 300°F.

Experiment 2

Further mercury control testing on the cyclone boiler described above was completed during summer while the SCR unit was out of service and the flue gas redirected around the SCR unit such that the flue gas was not exposed to the SCR catalytic surface. During the tests described, only the iodine-containing additive was applied and the iron-containing additive feed system was entirely shut down. Mercury stack emissions were monitored by the unit mercury CEM as previously discussed.

Testing was performed over a period of two months at several different concentrations of iodine-containing additive and with a bromine-containing salt added onto the coal belt. A reference condition with no coal additives applied was also tested. Test coal during the entire period was the same as for previous testing, an 8,800 BTU PRB coal. Flue gas temperatures measured at the air preheater outlet varied from 320 to 350°F, significantly higher than during the previous tests described in Experiment 1. For this coal, a number of coal mercury analyses averaged 71.95 ng/g total mercury content. This average coal value was used as the basis for mercury removal percentages at all conditions over the entire unit from boiler to stack. Note that there may have been some variation in coal mercury by coal shipment even though the same mine supply was maintained throughout the tests.

Each test condition was monitored for a period of days to a full week to ensure that the coal supply to each of the cyclones was 100% treated and mercury emissions were stabilized. Table 2 summarizes the data obtained with the unit at full load conditions. The iodine-containing additive was applied at the listed concentrations. The bromine-containing additive was applied at two concentrations.

Table 2: Experiment 2, Results with SCR Bypassed^{1,2}

Iodine or Bromine Addition to Coal (ppmw)	Added Iodine or Bromine:Hg Molar Ratio	Uncontrolled Mercury ($\mu\text{g/wscm}$) ¹	Controlled Mercury ($\mu\text{g/wscm}$)	Mercury Removal above Baseline (%)	Total Mercury Removal (%)
0	0	6.0	2.9	0%	51%
20	302	6.0	0.5	83%	92%
12	181	6.0	0.9	69%	85%
8	121	6.0	1.1	62%	82%
6	91	6.0	0.9	69%	85%
15 (Br)	359 (Br)	6.0	1.0	66%	83%
6 (Br)	144 (Br)	6.0	1.4	52%	77%

1. Average uncontrolled mercury concentration based on average coal analysis of 72 ng/g at full load coal rate and APH outlet gas flow.

2. Unit load was 280 MW or more for all of the tests with gas temperature at the APH outlet ranging from 320 to 350°F.

During the tests, the unit fly ash UBC percentage varied from 6% to 25% as measured post-test by fly ash taken from the electrostatic precipitator hoppers. Exact UBC during each test could not be determined based on hopper UBC content post-test, since hopper ash may not be entirely evacuated until days after it is removed from the ESP collection plates. Flue gas temperature at the inlet to the particulate control (ESP) varied from about 320 to 350°F. This was higher than the previous tests with the SCR in service, primarily due to summer vs. winter ambient conditions and the need to maintain peak load for extended periods.

Mercury removal, as calculated by the total from coal analysis to measured outlet mercury CEM, varied from 85 to 92%. With no treatment, mercury removal was approximately 51%.

This result shows that treatment by the iodine-containing additive is effective at higher process temperatures (e.g., from about 320 to 350°F at the ESP inlet) and without the benefit of an SCR catalyst.

Higher UBC is known to assist with native mercury capture by physisorption of oxidized mercury onto UBC carbon. However, at greater than 320°F, the physisorption of vapor mercury declines significantly. Thus, the addition of the iodine-containing additive, by itself, with no SCR catalysis effect was shown to improve higher temperature mercury removal to 90% or higher, but the form of mercury removed (particle-bound or vapor species) was not determined.

The bromine-containing additive treatment also increased mercury removal from 77 to 83% compared to 51% with no treatment. This result was unexpected on the basis of previous experience and industry understanding from other test sites. The expectation was that a significantly higher level of bromine addition would be required to realize a high rate of mercury removal. Higher UBC carbon in the cyclone boiler ash may be responsible for the excellent bromine performance with no SCR, but data on real-time in-situ UBC was not available to confirm this hypothesis.

Since mercury emission was measured at the stack, the speciation and form of mercury upstream was not explicitly measured, so the differences in mercury speciation as a result of iodine and bromine treatment were not evaluated by these tests.

Experiment 3

A series of tests were performed at Site A, a 360 MW coal-fired power plant firing Powder River Basin ("PRB") coal. The tests compared mercury removal when iodine was added to the coal at two concentrations (Experiment 3) and when a bromide additive was applied to the PRB coal (Experiment 4). The plant was firing 100% PRB coal before the tests began. The plant was equipped with a lime spray dryer ("SDA") followed by a fabric filter ("FF") baghouse (collectively "SDA/FF") for control of SO₂ and particulates. During the trial, semi-continuous mercury analyzers were located at the outlet of the air preheater upstream of the SDA and FF baghouse at the stack outlet.

The iodine content of the coal feed was provided by coal blending. Two blend ratios of PRB Black Thunder coal ("Black Thunder" or "BT") and higher iodine coal ("Coal B") were tested to evaluate the influence of the bituminous coal on mercury removal by native fly ash. The first blend ratio was nominally 92.7% Black Thunder and the

balance was Coal B. The second blend ratio consisted of 85.6% Black Thunder and the balance Coal B. Coal sulfur content for both blends was 0.4% dry basis. Coal ash calcium (CaO, dry basis) was 17.2% for the first and 18.4% for the second blend. The unit operated normally during the week except that one of the five coal mills, Mill C, was out of service.

Vapor-phase mercury concentrations were monitored at the outlet of the air preheater on the A-side of the unit and at the stack. A summary of the tests, including the blending ratios and the average mercury concentrations, is presented in Table 3 and Fig. 7. There were some operational problems associated with the inlet mercury analyzer immediately prior to beginning the first coal blending test that may have compromised the inlet concentrations measured. Therefore, a triplicate set of EPA Draft M324 (sorbent trap) samples were collected at the preheater outlet location for secondary mercury measurement. During the second test, simultaneous M324 samples were collected at the air pre-heater and stack.

Table 3. Vapor-Phase Mercury during Coal Blending Tests at Site A

Test Coal	Inlet Hg ($\mu\text{g}/\text{Nm}^3$)	Inlet Hg ⁰ ($\mu\text{g}/\text{Nm}^3$)	Outlet Hg ($\mu\text{g}/\text{Nm}^3$)	Outlet Hg ⁰ ($\mu\text{g}/\text{Nm}^3$)	Iodine enrichment (ppmw of coal feed)	Total Iodine (ppmw of coal feed)	Hg Removal (%)
100% JR PRB	9.8	8.1	10.4	9.6	0.0	0.4	-6 ^b
7.3% Coal B 92.7% BT	NA (7.24) ^{M324}	7.7	3.6	3.3	0.4	0.8	NA ^a (50) ^{M324}
14.4% Coal B 85.6% BT	5.8 (5.28) ^{M324}	5.4	1.4 (0.97) ^{M324}	1.4	0.7	1.1	76 (81) ^{M324}

All concentrations shown corrected to 3% molecular oxygen.

^a Analyzer operational problems – data suspect

^b Analyzer calibration drift, 0% Hg removal.

^{M324} Mercury concentration measured with EPA Draft M324

There was no measurable vapor-phase mercury removal measured while firing 100% Jacobs Ranch coal. At the first blend ratio, the mercury removal across the SDA-FF increased to 50%. The mercury removal during the second blend test increased to 76% (81% based upon M324 sorbent trap samples).

Coal B samples were tested for mineral and halogen constituents after the trial. Coal B samples were tested at 4.9 ppmw iodine in the coal by neutron activation analysis (NAA). The baseline PRB samples typically average 0.4 ppmw iodine. The resulting enrichment of iodine is shown in Table 2 above.

Experiment 4

One additional test at Site A was to add sodium bromide (NaBr) to the coal to increase the bromine concentration in the flue gas in an attempt to enhance mercury capture. No activated carbon was injected during this test.

NaBr was applied to the coal at the crusher house prior to entering the transfer house and coal bunkers. At this chemical injection location, it was estimated that it would take 4–5 hours before the "treated" coal would be fired in the boiler. The chemical additive was applied to the coal continuously for a period of 48 hours prior to injecting activated carbon to ensure that the entire system was "conditioned" with the additive.

During testing with NaBr injection, the unit was burning coal from the Jacobs Ranch mine. At normal operating conditions, the coal yielded a total vapor-phase mercury concentration of about 18 to about 22 $\mu\text{g}/\text{Nm}^3$ at the outlet of the air preheater with 70-90% in elemental form. During the chemical additive tests, the fraction of elemental mercury at the air preheater outlet decreased to about 20-30%.

Although the fraction of oxidized mercury at the inlet of the SDA increased substantially, no increase in mercury removal across the system was noted. The fraction of oxidized mercury at the outlet of the fabric filter was also lower (nominally 80% elemental mercury compared to typically >90% elemental mercury when NaBr was not present with the coal).

Experiments 3 and 4 illustrate the difference between the two halogen additives. In the case of iodine added by means of the blend coal, the mercury was being removed across the SDA-FF at up to 76% of total mercury, even though there was less than 1% UBC content in the ash/spray dryer solids. In the case of the bromine additive, there was increased vapor oxidized mercury at the SDA inlet but mainly elemental vapor mercury measured at the outlet with no increased mercury capture. In combination with iodine treatment on the coal, the SDA-FF provides fine spray solids and full mixing in a temperature range where heterogeneous reaction can occur.

Experiment 5

Coal blending tests were completed at other PRB coal-fired power plants, using various western bituminous coals in blend ratio to PRB of up to 20%. The results are shown in Table 4 below. None of the western bituminous blend coals in these trials that exhibited any significant mercury removal except the Coal B that is described in Experiments 3 and 4 above.

Table 4: Results of Western Bituminous Blend Tests For Mercury Control

Test/Unit	Blend Coal in PRB	APC Equipment	UBC Carbon (% of ash)	Blended Coal Iodine ppm	Mercury Removal (%)
Site B	ColoWyo, 20%	SDA/ESP	<1.0	<0.5 ⁽¹⁾	0
Site B	TwentyMile, 16%	SDA/ESP	0.6	<0.5 ⁽¹⁾	0

¹ Native iodine in western bituminous coals typically is less than 0.5 ppmw.

SDA - Spray Dryer Absorber, SO₂ Control

ESP - Electrostatic Precipitator

Experiment 6

Another test site for coal blending, Site D, fires subbituminous PRB coal and is configured with low-NO_x burners and selective catalytic reduction ("SCR") unit for NO_x control, a spray dryer absorber ("SDA") for SO₂ control, and a fabric filter ("FF") for particulate control. The test matrix included evaluating each coal at 7% and 14% higher iodine coal (Coal B) mixed with a balance of PRB. Each blend test was scheduled for nominally 16 hours with eight hours of system recovery time between tests. Coal A had a native iodine content of less than about 0.5 ppmw while coal B had a native iodine content of about 4.9 ppmw. Coal A sulfur content was 0.6 to 0.8%, dry basis. The blend coals averaged 0.65% sulfur. The coal ash calcium content, based on typical analysis of Coals A and B, was between 17 and 20% (CaO, dry basis).

For the first blend test (Coal B at 7.2%), there was a significant decrease in both the SDA inlet and stack mercury concentrations at the beginning of the test. However, there was no increase in oxidized mercury (Hg⁺²), which would suggest that, if this

decrease were due solely to the coal blend, mercury removal occurred in the particulate phase before reaching the SDA inlet sampling location. Based on this assumption, the mercury removal for the first test was about 50%, calculated using the mercury concentration at the beginning of the test and at its lowest point during the test. If removal is calculated strictly based on SDA inlet and outlet mercury concentrations, then removal increased from 10% to 27% due to coal blending.

During the second test (Coal B at 13.2%), the stack mercury levels gradually decreased, but the inlet did not. Based on the SDA inlet and stack concentrations, the mercury removal for the second test increased from about 15% to 51%. The iodine content of the coals was not analyzed at the time of testing, but the iodine content of Coal B has since been analyzed. Iodine enrichment compared to the baseline PRB coal was approximately 0.7 ppmw at the 14% blend ratio, based on typical iodine analysis for Coal B. The iodine/mercury molar ratio was approximately 30. Surprisingly, mercury removal was more than 50% even at this low additive rate.

Experiment 7

A trial of mercury control when firing an iodine treated coal was completed on a 70 MW, wall-fired unit firing a Powder River Basin coal. The purpose of this test was to compare the mercury removal of the treated coal product on mercury emissions compared to the identical coal at the same process conditions without treatment. The coal was treated remotely by application of an aqueous iodine-containing solution by spray contact with the coal. A unit train was loaded with about half untreated and half treated coal. The level of treatment based on coal weight and chemical applied was 7.6 ppmw of iodine in the as-loaded coal. The concentrated chemical spray was applied to substantially all of the coal and was well-distributed.

At the power plant, the untreated coal from this unit train was fired for six days and then the first treated coal was introduced. Treated coal was then burned exclusively in this unit for another seven days. Coal sulfur content averaged 0.35%, dry basis. Coal ash calcium content was 20.9%, dry basis, CaO.

Coal samples taken at the plant from the coal feed to the boiler were analyzed for halogen content by neutron activation analysis (NAA). Samples during the baseline period averaged 26.0 µg/g chlorine as-received, 1.2 µg/g bromine and 0.4 µg/g iodine. Samples taken while firing treated coal averaged 18.9 µg/g chlorine as-received, 1.1 µg/g bromine

and 3.0 µg/g iodine. The results for iodine indicated loss during transit and handling (7.6 µg/g as loaded and 3.0 as-received). However, the coal sampling and analytical frequency was lower than necessary to conclusively determine this.

The plant pollution control equipment consisted of a cold-side electrostatic precipitator operating at an inlet flue gas temperature of 360°F to 400°F. The level of unburned carbon (loss-on-ignition) was 0.7% or essentially none in the PRB fly ash. In addition, the mercury speciation as measured by the outlet mercury monitor was initially almost all elemental mercury. These conditions were expected to be extremely problematic for conventional mercury control such as activated carbon injection (ACI) or bromine treatment of coal. For ACI, the temperature was too high for substantial elemental mercury sorption except at higher injection rates with halogenated activated carbon. This would be expensive and would add carbon detrimentally into the fly ash. Bromine treatment of coal would be expected to increase the oxidation of mercury when applied as typically practiced at 30 to 100 ppm on the coal, but the lack of unburned carbon in the fly ash would limit capture of the oxidized mercury species. It would not be unexpected to see no mercury capture for this condition with bromine added to the coal.

A modular rack Thermo Fisher mercury continuous emission monitor (Hg-CEM) was installed at the ESP outlet (ID fan inlet) to measure the total and elemental mercury in the flue gas. The monitor directly read mercury concentration in the flue gas on one-minute average intervals in units of micrograms mercury per standard cubic meter of flue gas, wet basis (µg/wscm).

The treated coal first reached the boiler from only one of 3 bunkers and the mercury concentration at full load rapidly decreased from 5 to 2.6 µg/wscm (0.0041 to 0.0021 ppmw in the flue gas) or about 50% reduction. After all the coal feed switched to treated, the mercury decreased slightly more and remained lower. Overall, the average baseline mercury concentration measured at the stack outlet when initially burning the coal with no iodine treatment was about 5.5 µg/wscm (0.0045 ppmw) at high load above 70 MW and 1.7 µg/wscm (0.0014 ppmw) at low load of about 45 MW. When firing treated coal, the high load Hg concentration averaged about 2.6 µg/wscm (0.0021 ppmw) and the low load about 0.8 µg/wscm (0.0006 ppmw). The use of treated coal reduced mercury emission by about 53%. In addition, episodes of extreme mercury spikes during high temperature excursions related to soot blowing were substantially eliminated. After the unit came back

from an outage, the regular coal feed (untreated) was resumed and the mercury emissions returned to baseline of about 5.5 µg/wscm (0.0045 ppmw) at full load.

In addition to reducing the total mercury by converting to a particulate form, the additive also appears to have converted the majority of the remaining vapor phase mercury to an oxidized form. This creates an opportunity to obtain additional mercury capture with the injection of a low-cost untreated sorbent. If the mercury were not converted to an oxidized form, additional trimming of the mercury emissions would require a more expensive brominated sorbent.

In order to further validate the mercury measurements, a set of independent emissions tests were completed using a sorbent trap method (EPA Method 30B). The sorbent trap emissions agreed well with the Hg-CEM throughout the trial.

Total mercury removal in this trial was more than 50% for a difficult process condition (PRB coal, gas temperature 350 to 400°F, no UBC and undersized electrostatic precipitator) for which zero or minimal removal would be expected by either injection of activated carbon or bromine treatment of feed coal.

Experiment 8

A trial of mercury control by addition of coal additives was completed on a cyclone-fired boiler rated at 600 MW gross electricity production, but capable of short-term peak production of 620 MW. The boiler configuration was 14 cyclone combustors arranged three over four on the front and rear walls. Each cyclone burns approximately 50,000 lb/h of Powder River Basin (PRB) coal at full load. The coal sulfur content was 0.3% (dry basis) and the coal ash calcium content (CaO) averaged 22% (dry basis).

NO_x emissions are controlled on this unit by Overfire Air (OFA) ports located on the front and rear walls, and by a Selective Catalytic Reduction (SCR) system located upstream of the air preheater. There are no Hg controls on this boiler, but a portion of the mercury released during combustion is retained by unburned carbon particles captured in the electrostatic precipitator.

A liquid-phase iodine-containing additive, that was substantially free of bromine and chlorine, and a solid-phase iron-containing additive were added to the furnace. The additives were applied to the coal upstream of the crusher house. The solid-phase iron-containing additive was provided in granular form that was stored in a bulk storage pile located in close proximity to the iron-containing additive conveying equipment. The

liquid iodine-containing additive was delivered in Intermediate Bulk Container (IBC) totes. The liquid material was metered by a chemical pump to a dispensing nozzle at the top of the bucket elevator where it was combined with the iron-containing additive prior to being dropped onto the coal supply belt. The feed rate of both the solid iron-containing additive and the liquid iodine-containing additive was controlled to an adjustable set-point based on the weight of coal being fed on the coal belt.

The test period included several days of operation with and without additive coal treatment. The initial test period was deemed the "Baseline Tests" conducted to quantify the native or untreated Hg emissions in the stack and the baseline NO_x emissions. Then, additive treatment using both additives began.

Mercury reduction was demonstrated using data from a Thermo Fisher Mercury CEM on the stack (downstream from the ESP). Based on historical coal analyses, the uncontrolled Hg emissions were expected to vary between 5 and 10 µg/wscm. Coal mercury content was analyzed during the trial and averaged 68.7 ng/g. Based on this and the flue gas flow rate, the expected mercury concentration in the flue gas at the air preheater outlet was 5.8 µg/wscm (0.0005 ppmw).

Due to the high amount of unburned carbon in the fly ash (10-20%) and low flue gas temperatures (< 300°F), there was significant native mercury removal without the iodine additive. During the baseline period, vapor-phase Hg concentrations as measured by the stack outlet Hg-CEM ranged from 0.2 to 1.1 µg/wscm (0.0002 to 0.0009 ppmw) with an average of about 0.6 µg/wscm. Iodine was then added to the coal feed at various concentrations and mercury emissions dropped to the range of 0.03 to 0.13 µg/wscm (0.00002 to 0.0001 ppmw). Overall mercury removal, coal pile to stack, at this condition was > 98%. Additional mercury reduction from the baseline condition ranged from 78 to 95 percent, with an average of 78 percent reduction at a feed rate equivalent to 3 ppm by weight of iodine on the coal.

Sorbent Trap method (STMs) using a modified EPA Method 30-B were conducted during baseline tests to substantiate the Hg-CEM measurements. The STMs all agreed with the Hg-CEM agreed within specified limits (%Relative Accuracy < 20%). During additive injection, STMs were not conducted at the extremely low mercury conditions, due to the prohibitively long STM sample times in order to collect enough mercury to be above the detection limit of the analysis.

This experiment demonstrates the ability to economically achieve a critical 90% mercury removal with only 3 ppmw iodine in combination with iron additive added to the coal feed, without the need for expensive additional mercury control equipment.

Table 5: Experiment 8 Results

Iodine Addition to Coal (ppmw)	Added Iodine/Hg Molar Ratio	Uncontrolled Mercury ($\mu\text{g/wscm}$) ¹	Controlled Mercury ($\mu\text{g/wscm}$)	Mercury Removal above Baseline (%)	Total Mercury Removal (%)
0	0	5.8	0.6	0%	90%
3	47	5.8	0.13	78%	98%

¹. Average uncontrolled mercury concentration based on average coal analysis of 69 ng/g at full load coal rate and APH outlet gas flow.

Experiment 9

The objective of three tests, described below, was to assess the stability of elemental iodine adsorbed on a porous carbonaceous material (*i.e.*, activated carbon) by exposing the loaded carbon to different temperatures for extended periods of time.

In the first test, elemental iodine was formed by oxidizing 1000 ppm iodide solution by acidifying it, and adding a small amount of hydrogen peroxide. The iodine solution was then passed through a bed of activated carbon in a filter funnel. The carbon is considered to be loaded when the yellow color of iodine in water breaks through the carbon bed. Four hundred twenty five milligrams of iodine per gram of carbon was adsorbed on Sabre™ powdered activated carbon ("PAC") with this method.

The loaded carbon was dried, and a weighed amount placed in an Erlenmeyer flask with the neck plugged with a filter paper saturated with soluble starch solution. The temperature of the flask was raised to ~50° C and held for one hour. Only a faint purple color developed on the starch paper indicating that only a trace of iodine was driven off the carbon at this temperature

In a second test, Sabre™ PAC was loaded with iodine using the iodine number procedure. This test indicated that 1,079 mg of iodine was sorbed per gram of carbon. Note that in this procedure the carbon filter cake is not washed; thus some the iodine can be held interstitially and is not strictly sorbed to the carbon.

A slight purple color formed on the starch paper at a temperature of 30° C and significant color and small iodine crystals developed on the paper when the temperature reached 50° C. The temperature was raised to about 80° C, and dense iodine vapors formed above the carbon.

Once cooled, a 0.25 gram portion was reacted with 50 ml of an alkaline hydrogen peroxide solution for 15 minutes to remove the iodine from the carbon by reducing it to iodide. The percentage of iodine retained on the carbon after heating to ~80° C was calculated to be about 200 mg/g of carbon.

In a third test, an iodine solution was made so that up to 500 mg/g was available when reacted with two grams of Sabre™ PAC. After washing, filtering, and drying, a portion was analyzed to determine the amount of iodine adsorbed. About 360 mg I₂/g carbon was adsorbed.

The method of stripping the iodine from activated carbon by reducing it to iodide with hydrogen peroxide appears to be quantitative as tests performed on the stripped carbon with isopropyl alcohol, which has previously been shown to strip iodine from activated carbon, were negative.

Another portion of the loaded carbon was heated to 50° C and held at that temperature for 1.5 hours with only a small amount of iodine liberated as indicated by the starch paper. The carbon was cooled and stripped of iodine. The iodide concentration of the strip solution was measured. The amount of iodine retained by the carbon after heating to 50° C was found to be 280 mg I₂/g Sabre™ PAC.

Another portion of iodine loaded carbon was heated to more than 80° C to drive off more iodine, and the carbon analyzed as in the above paragraph. The amount of iodine retained after this extreme heating was 320 mg I₂/g Sabre™ PAC.

These tests indicate that Sabre™ PAC holds between 200 and 300 mg of iodine per gram of carbon with sufficient tenacity to be stable up to about 80° C and greater amounts are fairly stable at 25° C.

Significantly, loadings of up to 360 mg/g were achieved. In later tests with some high microporosity carbons, loadings of 50 to 100% were obtained. While the iodine becomes less energetically adsorbed and may evolve some vapor off the carbon at very high loadings, these tests demonstrate that a high quality carbon can be used since the quantities required are no more than about 3 lbs. per lb. of iodine. Also, in some

configurations, the iodine could be desorbed off the carbon and into the flue gas by heating, for example, and the carbon re-used.

Experiment 10

A trial was conducted to evaluate mercury removal at a 450 MW coal-fired cyclone boiler during treatment of coal with an iodine-containing additive. The plant was configured with an SCR, rotary air preheater (APH) and a cold-side ESP. The plant was burning a mixture of 85% PRB and 15% low-sulfur Eastern bituminous coal. Coal sulfur content was 0.4%, dry basis and coal ash calcium content was about 17% as CaO, dry basis.

A liquid-phase iodine-containing additive, substantially free of bromine and chlorine, was added to the coal at 6 to 13 ppm by weight of halogen to the coal feed for a period of three days. Total and speciated mercury (elemental and oxidized) was measured continuously using a Thermo Fisher Mercury CEM on the stack (downstream from the ESP). Prior to halogen addition, the total mercury was 2 µg/wscm and the oxidized mercury fraction was approximately 50%. Iodine was added to the coal at a first rate of 6 ppm_w and then at a second rate as high as 13 ppm_w. Injection of halogen immediately increased the Hg oxidation at the stack from 50% to 90%. However, total mercury emissions as measured at the stack were not substantially affected even after 3 days of injection. Table 6 summarizes the trial results.

Table 6: Experiment 10 Results

Iodine Addition to Coal (ppmw)	Total Mercury (µg/wscm) ¹	Oxidized Mercury (%)	Mercury Removal above Baseline (%)
0 (Baseline)	2.0	30 - 60	0%
6	1.5 – 2.0	70 - 90	< 25%
13	1.5 – 2.0	90 - 100	< 25%

The SO₂ emissions during the testing were monitored by the stack continuous emission monitors. The SO₂ emissions during the trial were 0.75 to 0.8 lb/MMBtu. The air preheater exit temperature fluctuated between about 260°F at 350 MW and 320°F at 450 MW. The oxidation rate of SO₂ across the SCR was estimated to be 1.9% at full load and 0.3% at low load, based on prior measurements of SO₃ made at the SCR inlet and outlet. The formation and deposition of SO₃ through the SCR to the stack was modeled to

estimate SO₃ concentrations after the SCR at low load and full load. At full load, the SO₃ at the APH outlet was estimated to be about 7 ppmvd, but at low load (350 MW), less than 1 ppmvd. Table 7 summarizes the model results.

Table 7: SO₃ Model Prediction for 85% PRB blend

Load, MW	450	350
ESP Inlet Temperature	320	260
SO₃, ppmvd at 3% O₂		
SCR inlet	2.9	2.9
SCR outlet	11.3	4.2
ESP inlet	6.9	0.4
Stack	4.4	0.3

The SO₃ at the outlet of the APH (ESP inlet) is lower at low load for two reasons (1) lower temperatures in the SCR mean less SO₂ will be oxidized and (2) lower temperatures at the APH outlet mean more removal of SO₃ across the APH. At low load with iodine treatment of the coal, reduced SO₂ to SO₃ oxidation plus reduced ammonia for deNO_x, the mercury was 100% oxidized. At full load, however, there was an excess of SO₃ of as much as 7 ppm_v, that blocks mercury reaction on ESP fly ash surface sites.

Doubling the rate of halogen coal additive in this case increased the mercury oxidized fraction, but was not effective in increasing mercury removal (due to the excess SO₃). This trial illustrates again that very low levels of halogen (6 ppmw of coal feed) are required with SCR to oxidize the majority of mercury, but it also demonstrates the sensitivity of mercury capture to SO₃ levels at the ESP and, in this case, the undesirable SO₂ to SO₃ oxidation occurring in the SCR. Even though a low-sulfur coal is being fired, the overall emissions of SO₂ is low and the mercury is present almost entirely in an oxidized form when a halogen coal additive is present, the catalytic formation of SO₃ across the SCR and its deposition on mercury capture surfaces, especially in the ESP, are still very detrimental to mercury retention in the fly ash.

A number of variations and modifications of the disclosure can be used. It would be possible to provide for some features of the disclosure without providing others.

For example in one alternative embodiment, coal containing naturally high concentrations of iodine (e.g., greater than about 2 ppmw, even more typically greater than about 3 ppmw, and even more typically greater than about 4 ppmw) is blended with the

feedstock coal having no or low concentrations of iodine (e.g., no more than about 2 ppmw and even more commonly no more than about 1 ppm by weight) to increase mercury removal. The coal, when fired, can have high or low UBC content without adversely impacting mercury removal.

The present disclosure, in various aspects, embodiments, and configurations, includes components, methods, processes, systems and/or apparatus substantially as depicted and described herein, including various aspects, embodiments, configurations, subcombinations, and subsets thereof. Those of skill in the art will understand how to make and use the various aspects, aspects, embodiments, and configurations, after understanding the present disclosure. The present disclosure, in various aspects, embodiments, and configurations, includes providing devices and processes in the absence of items not depicted and/or described herein or in various aspects, embodiments, and configurations hereof, including in the absence of such items as may have been used in previous devices or processes, e.g., for improving performance, achieving ease and/or reducing cost of implementation.

The foregoing discussion of the disclosure has been presented for purposes of illustration and description. The foregoing is not intended to limit the disclosure to the form or forms disclosed herein. In the foregoing Detailed Description for example, various features of the disclosure are grouped together in one or more, aspects, embodiments, and configurations for the purpose of streamlining the disclosure. The features of the aspects, embodiments, and configurations of the disclosure may be combined in alternate aspects, embodiments, and configurations other than those discussed above. This method of disclosure is not to be interpreted as reflecting an intention that the claimed disclosure requires more features than are expressly recited in each claim. Rather, as the following claims reflect, inventive aspects lie in less than all features of a single foregoing disclosed aspects, embodiments, and configurations. Thus, the following claims are hereby incorporated into this Detailed Description, with each claim standing on its own as a separate preferred embodiment of the disclosure.

Moreover, though the description of the disclosure has included description of one or more aspects, embodiments, or configurations and certain variations and modifications, other variations, combinations, and modifications are within the scope of the disclosure, e.g., as may be within the skill and knowledge of those in the art, after understanding the present disclosure. It is intended to obtain rights which include alternative aspects,

embodiments, and configurations to the extent permitted, including alternate, interchangeable and/or equivalent structures, functions, ranges or steps to those claimed, whether or not such alternate, interchangeable and/or equivalent structures, functions, ranges or steps are disclosed herein, and without intending to publicly dedicate any patentable subject matter.

What is claimed is:

1. A method, comprising:

providing a mercury-containing feed material comprising (i) an iodine-containing additive and (ii) a combustible carbon-containing material including mercury;

generating from the mercury-containing feed material a mercury-containing gas stream comprising vapor-phase elemental mercury and the iodine-containing additive, the iodine-containing additive comprising a vapor-phase iodine;

contacting the mercury-containing gas stream with a reactive surface agent upstream of an air preheater, the reactive surface agent and the vapor-phase iodine converting at least a portion of the vapor-phase elemental mercury into an ionic mercury collected on the reactive surface agent, wherein at least one of the following is true: (a) the reactive surface agent comprises a porous carbonaceous material and the reactive surface agent is added to the mercury-containing gas stream and (b) the reactive surface agent comprises a noncarbonaceous material or a carbonaceous material that is not substantially rich in carbon on which the ionic mercury collects; and

removing the reactive surface agent with the ionic mercury thereon from the mercury-containing gas stream.

2. The method of claim 1, wherein the mercury-containing feed material comprises not more than 3 ppmw iodine.

3. The method of claim 2, wherein the portion of the elemental mercury that is converted into the ionic mercury and collected on the reactive surface agent is between 70 percent and 90 percent by weight.

4. The method of claim 1, wherein the combustible carbon-containing material additionally comprises a native halogen.
5. The method of claim 1, wherein the combustible carbon-containing material is coal and wherein the reactive surface agent comprises a mercury-active agent.
6. The method of claim 5, wherein the reactive surface agent is a base metal oxide.
7. The method of claim 6, wherein the base metal oxide is one or more of iron oxide, nickel oxide, lead oxide, zinc oxide, and copper oxide.
8. The method of claim 1, wherein the combustible carbon-containing material is coal and wherein (b) is true and wherein the reactive surface agent is one or more of zeolites, silica, silica alumina, alumina, gamma-alumina, activated alumina, acidified alumina, amorphous aluminosilicates, crystalline aluminosilicates, amorphous silica alumina, ion exchange resins, clay, a transition metal sulfate, porous ceramics, trona, alkali metal bicarbonates, alkali metal bisulfates, alkali metal bisulfites, alkali metal sulfides, elemental sulfur, limestone, hydrated lime, slaked lime, fumed silicates, metal oxide particles, metal oxide powders, iron oxide particles, iron oxide powders, iron oxide particles having labile anions, and iron oxide powders having labile anions.
9. The method of claim 1, wherein the combustible carbon-containing material is coal, wherein the reactive surface agent comprises one or more of circulating fluidized bed ash, fluidized catalytic cracker fines, re-milled fly ash, fine fraction fly ash, bottom ash, and fluidized bed combustor ash.
10. The method of claim 1, wherein at least 75% of the iodine-containing additive in the gas stream is the vapor-phase iodine.
11. The method of claim 1, wherein at least 85% of the iodine-containing additive in the gas stream is the vapor-phase iodine.

12. The method of claim 1, wherein at least 95% of the iodine-containing additive in the gas stream is the vapor-phase iodine.
13. The method of claim 1, wherein (b) is true and wherein the reactive surface agent provides a site for nucleating and/or reacting with one or more of iodine, mercury, and mercuric iodide.
14. The method of claim 1, wherein the combustible carbon-containing material is coal and wherein an unburned carbon content of the mercury-containing gas stream is no more than 5%.
15. The method of claim 14, wherein the unburned carbon content of the mercury-containing gas stream is no more than 0.5%.
16. The method of claim 1, wherein the combustible carbon-containing material is coal, wherein (b) is true and wherein the reactive surface agent is one or more of zeolites, silica, silica alumina, alumina, gamma-alumina, activated alumina, acidified alumina, amorphous aluminosilicates, crystalline aluminosilicates, amorphous silica alumina, ion exchange resins, clay, a transition metal sulfate, porous ceramics, trona, alkali metal bicarbonates, alkali metal bisulfates, alkali metal bisulfites, alkali metal sulfides, elemental sulfur, limestone, hydrated lime, slaked lime, fumed silicates, metal oxide particles, metal oxide powders, iron oxide particles, iron oxide powders, iron oxide particles having labile anions, iron oxide powders having labile anions, and mixtures thereof and at least one of the following is true: (a) the reactive surface agent has a P₈₅ size of substantially 1 mm or less in size and an average diameter between 0.10 mm to 0.75 mm and (b) the reactive surface agent has a P₈₅ size of substantially 1 mm or more in size and an average diameter between 0.75 mm to 1.25 mm.
17. The method of claim 1, wherein the combustible carbon-containing material is coal and wherein (a) is true.

18. A method, comprising:

providing a mercury-containing gas stream comprising vapor-phase elemental mercury, wherein the mercury-containing gas stream is derived from combustion of a mercury-containing feed material prepared prior to combustion comprising (i) an iodine-containing additive and (ii) a combustible carbon-containing material comprising mercury;

contacting the mercury-containing gas stream with a carbonaceous reactive surface agent upstream of an air preheater;

collecting at least a portion of the mercury and iodine from the iodine-containing additive in the mercury-containing gas stream on the carbonaceous reactive surface agent to form a mercury-loaded reactive surface agent; and

removing the mercury-loaded reactive surface agent from the gas stream, wherein at least one of the following is true: (a) the carbonaceous reactive surface agent is added to the mercury-containing gas stream and (b) the carbonaceous reactive surface agent additionally comprises coal ash, unburned carbon and/or coal derivatives in the mercury-containing gas stream that are derived from combustion of the mercury-containing feed material.

19. The method of claim 18, wherein the combustible carbon-containing material additionally comprises a native halogen.

20. The method of claim 18, wherein the combustible carbon-containing material is coal and wherein the carbonaceous reactive surface agent is a porous carbonaceous material, the porous carbonaceous material being one or more of coal ash, fly ash, bottom ash, unburned coal, charcoal, char, and coke.

21. The method of claim 18, wherein the combustible carbon-containing material is coal and wherein the carbonaceous surface reactive agent is one or more of carbon black and activated carbon.
22. The method of claim 18, wherein the combustible carbon-containing material is coal and wherein (a) is true.
23. The method of claim 22, wherein the mercury-containing gas stream has an unburned carbon content of no more than 0.5%.
24. The method of claim 18, wherein the combustible carbon-containing material is coal and wherein (b) is true.
25. A method, comprising:

generating a mercury-containing gas stream comprising vapor-phase elemental mercury and vapor-phase iodine from a mercury-containing feed material comprising:

(i) a combustible carbon-containing material comprising mercury,
and

(ii) an iodine-containing additive;

contacting the mercury-containing gas stream with a reactive surface agent upstream of an air preheater, the reactive surface agent comprising a mercury-active agent and wherein the mercury-active agent is a base metal oxide, the reactive surface agent being halogenated by the vapor phase iodine, wherein upon contacting the mercury-containing gas with the reactive surface agent, at least a portion of the vapor-phase elemental mercury is converted into ionic mercury that is collected on the reactive surface agent; and

removing the reactive surface agent with the ionic mercury thereon from the mercury-containing gas stream.

26. The method of claim 25, wherein the combustible carbon-containing material additionally comprises a native halogen.
27. The method of claim 25, wherein the combustible carbon-containing material is coal and wherein the base metal oxide is one or more of iron oxide, nickel oxide, lead oxide, zinc oxide, and copper oxide.
28. The method of claim 27, wherein the reactive surface agent comprises one or more of a porous carbonaceous material and at least one of the following is true: (a) the reactive surface agent has a P₈₅ size of about 1 mm or less in size and an average diameter between 0.10 mm to 0.75 mm and (b) the reactive surface agent has a P₈₅ size of about 1 mm or more in size and an average diameter between 0.75 mm to 1.25 mm.
29. The method of claim 25, wherein the mercury-containing feed material comprises not more than 3 ppmw iodine.
30. The method of claim 29, wherein the portion of the elemental mercury that is converted into the ionic mercury and collected on the reactive surface agent is between about 70 percent and 90 percent by weight.

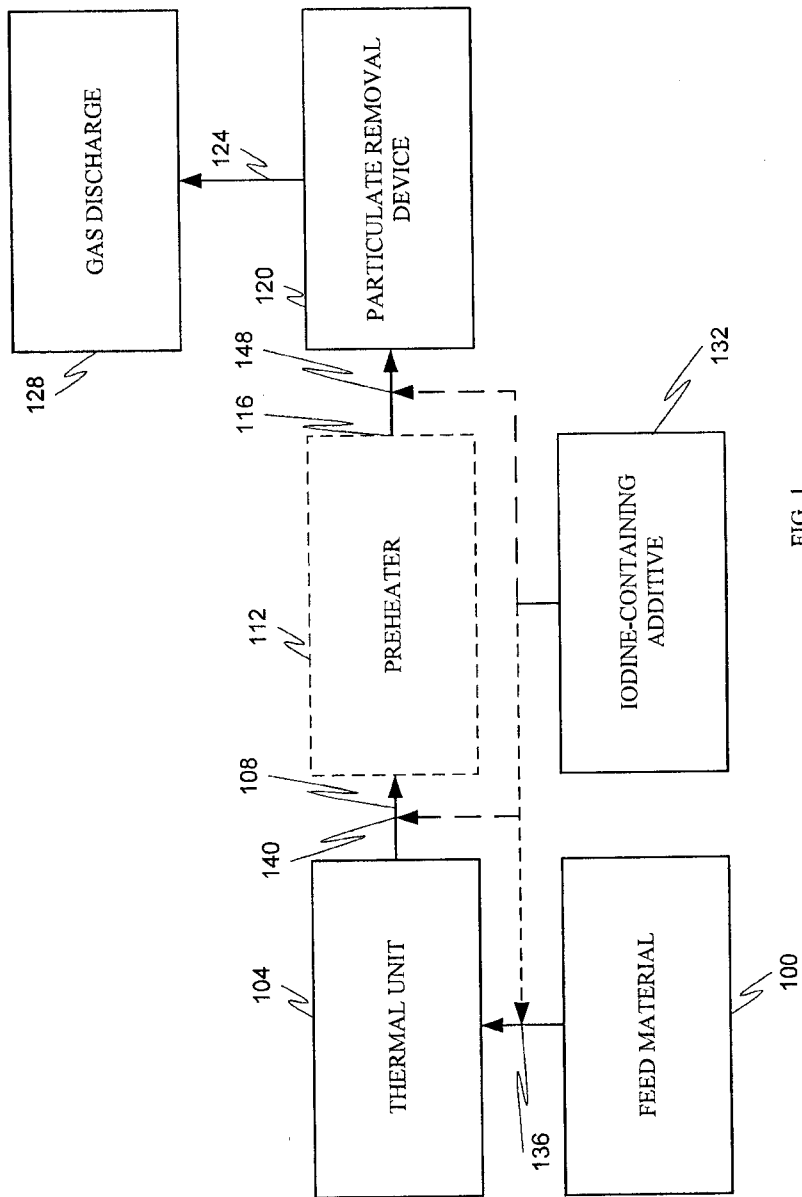

FIG. 1

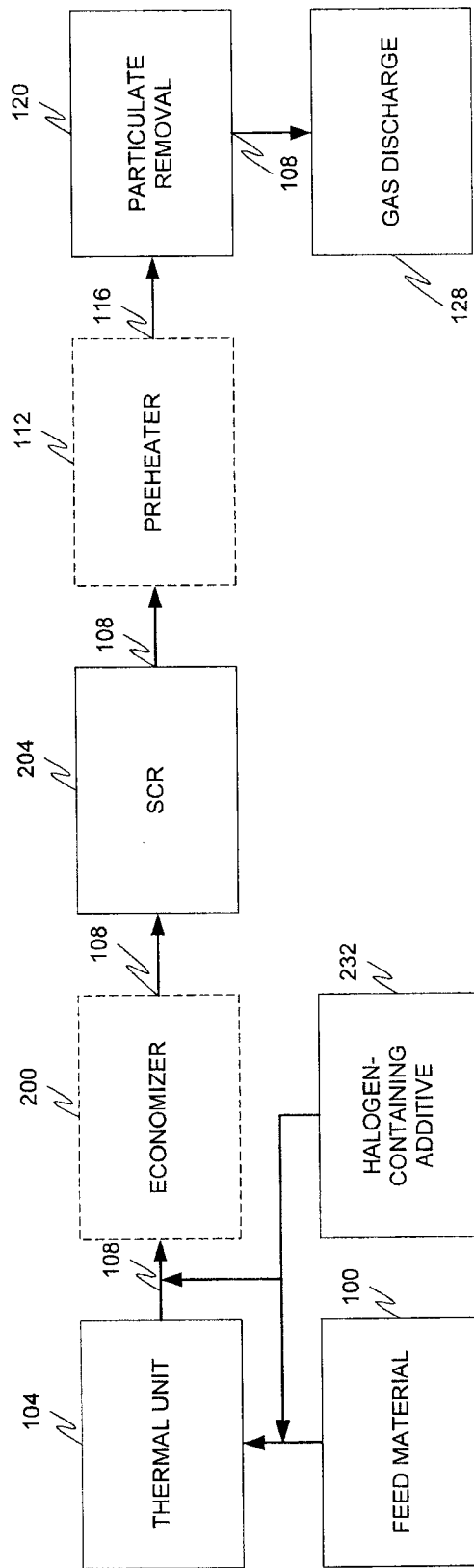

FIG. 2

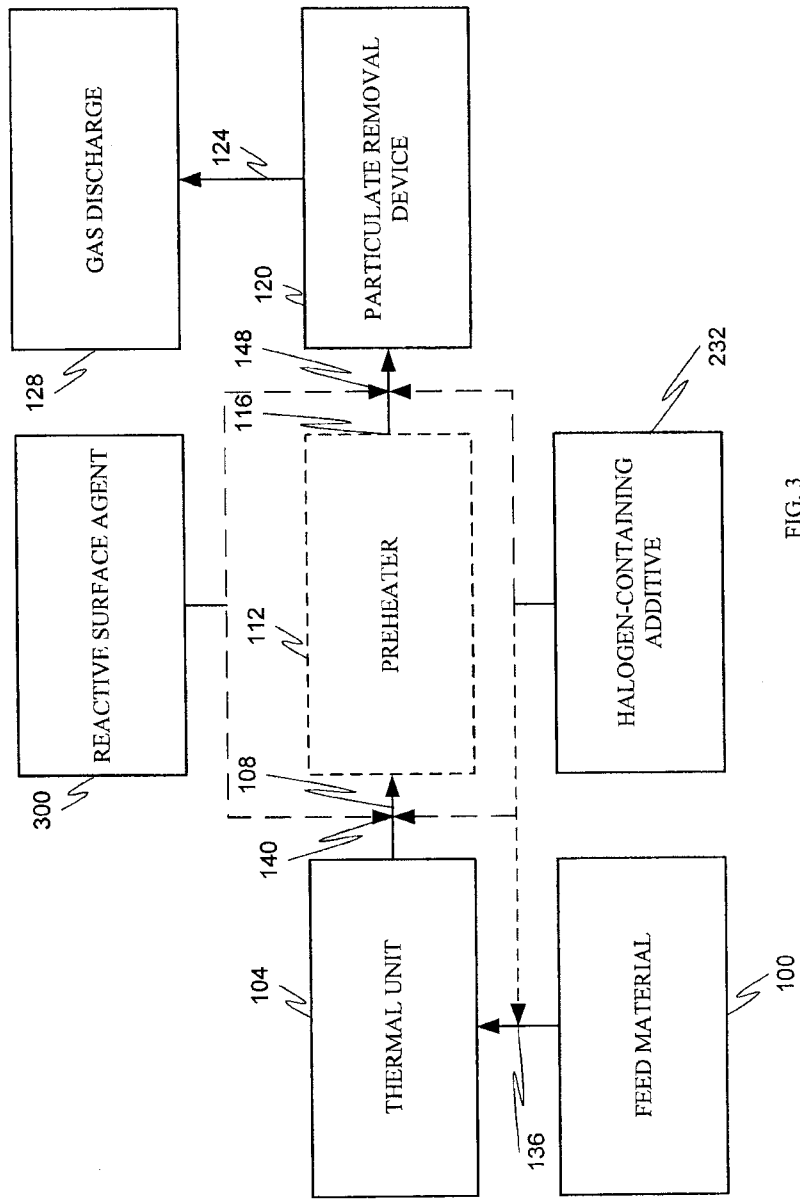

FIG. 3

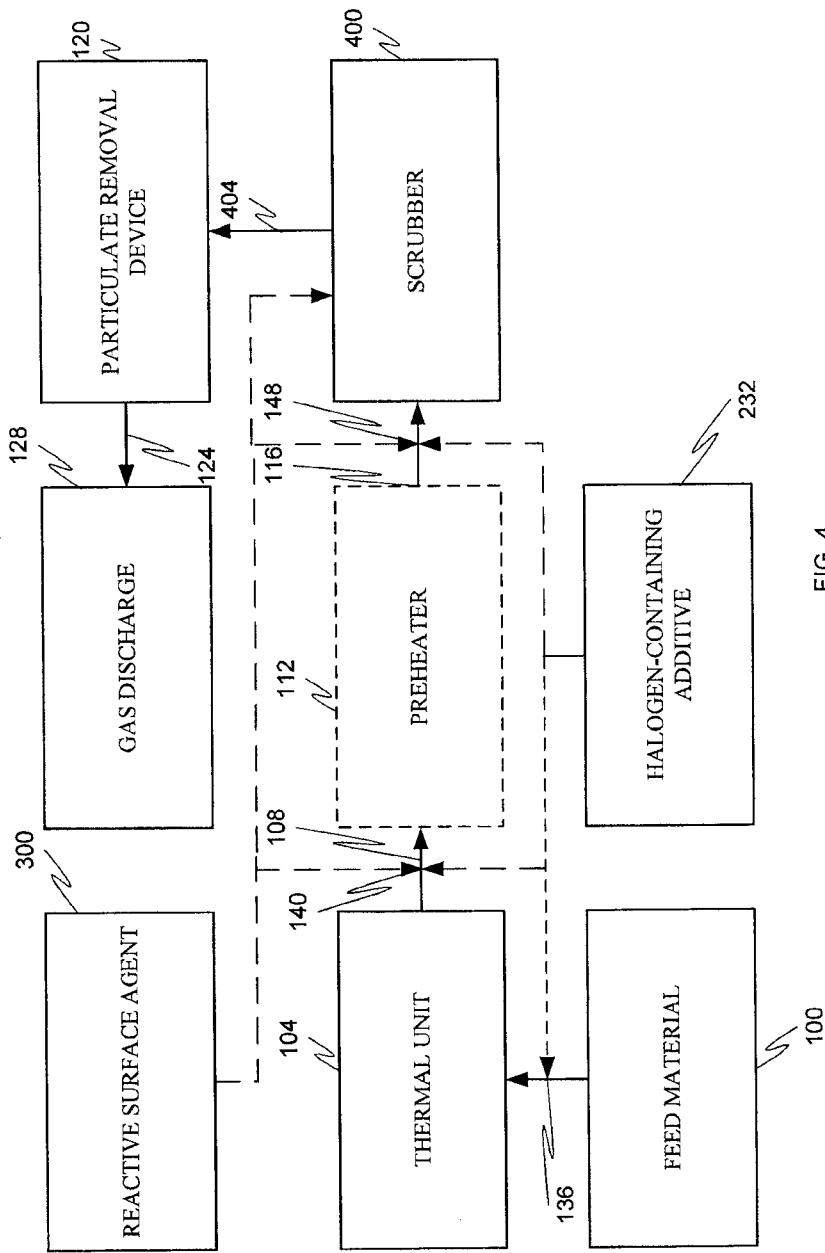

FIG. 4

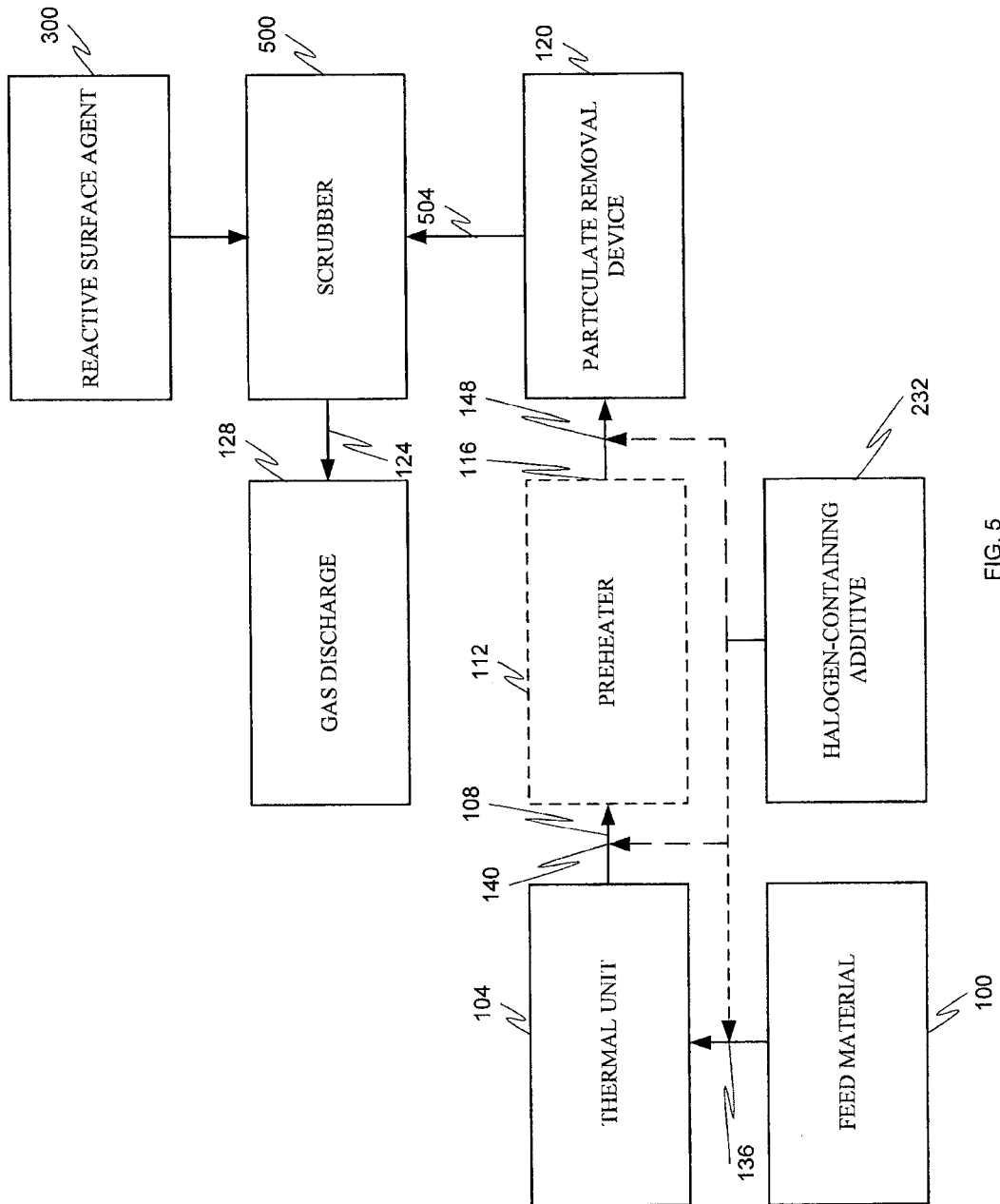

FIG. 5

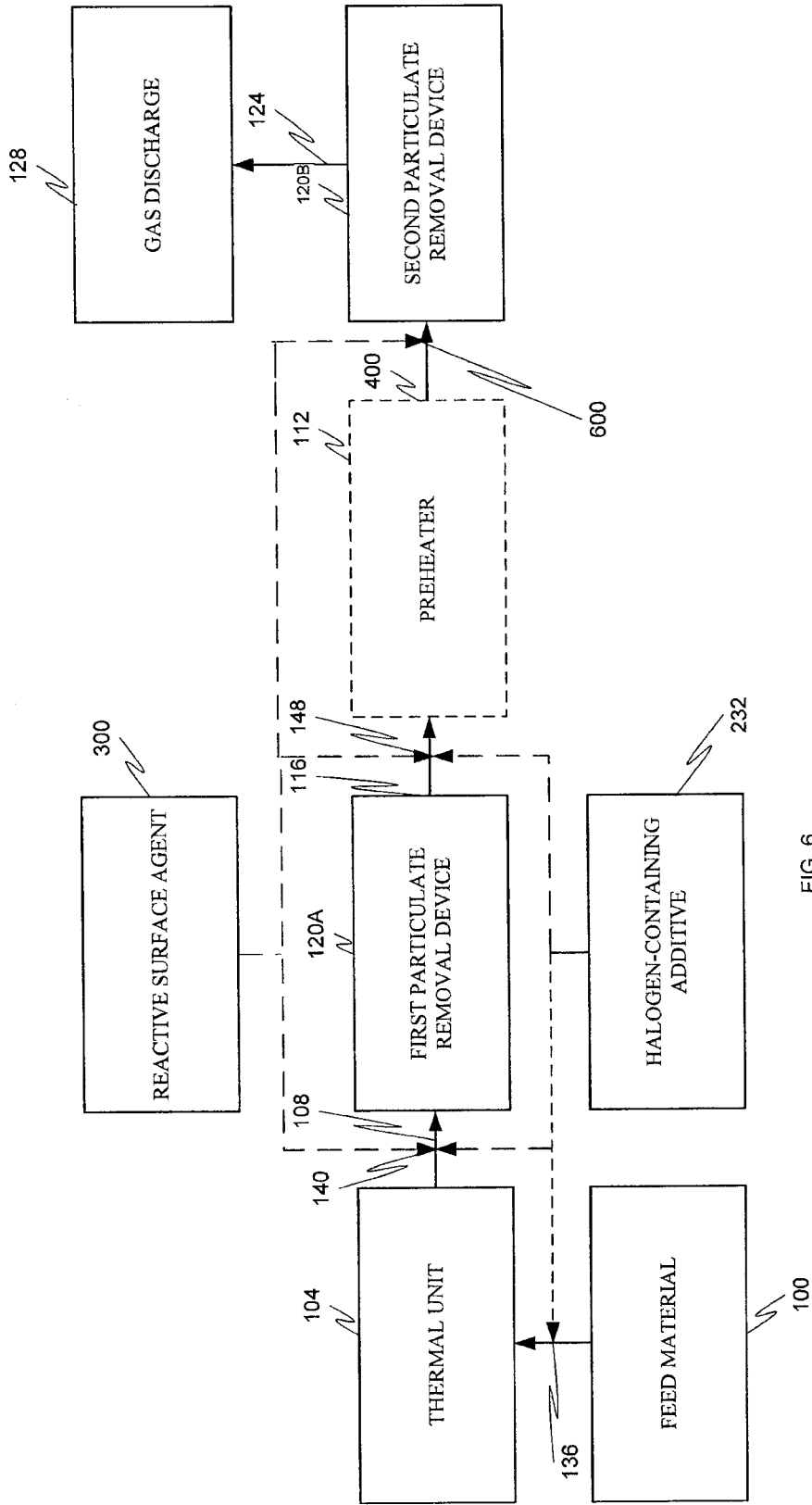

FIG. 6

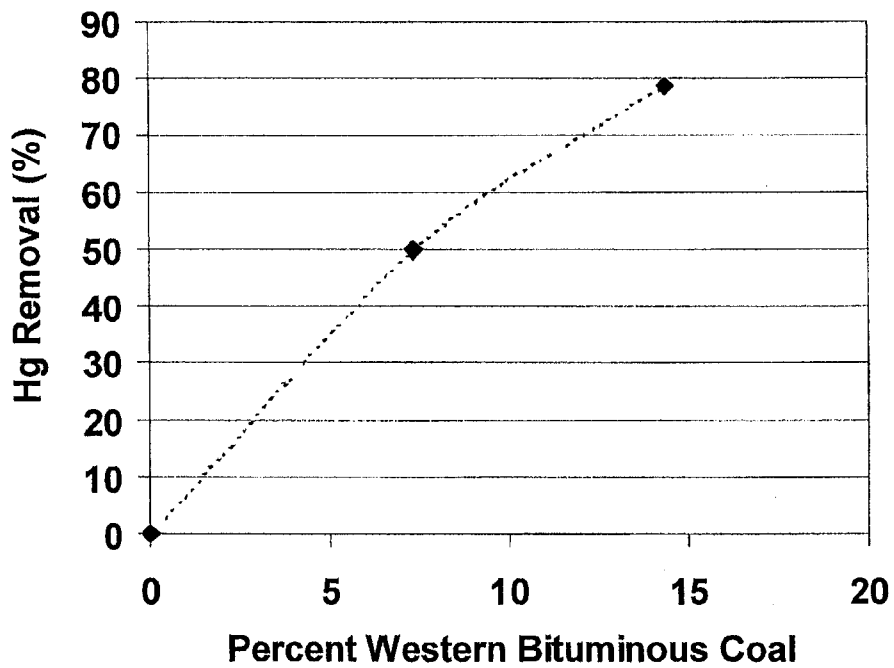

Figure 7. Results of Coal Blending Tests, Experiment #3

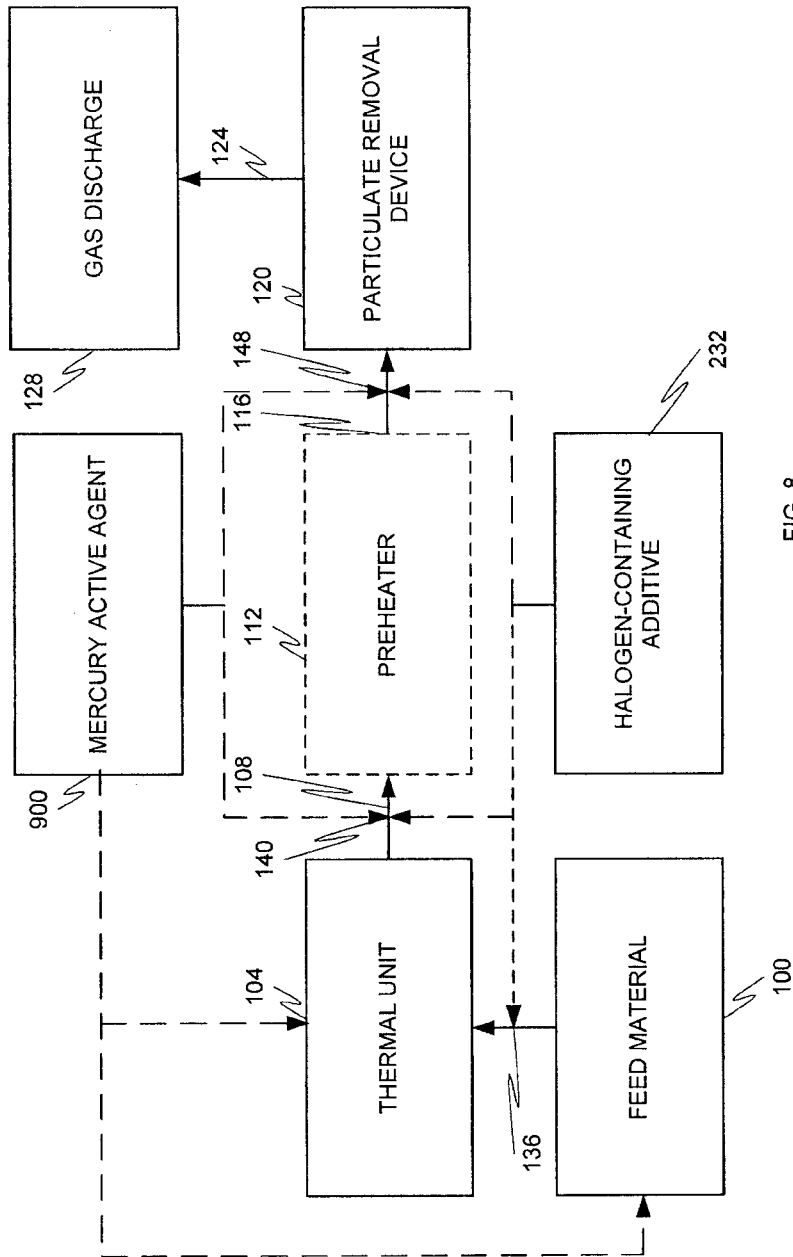

FIG. 8

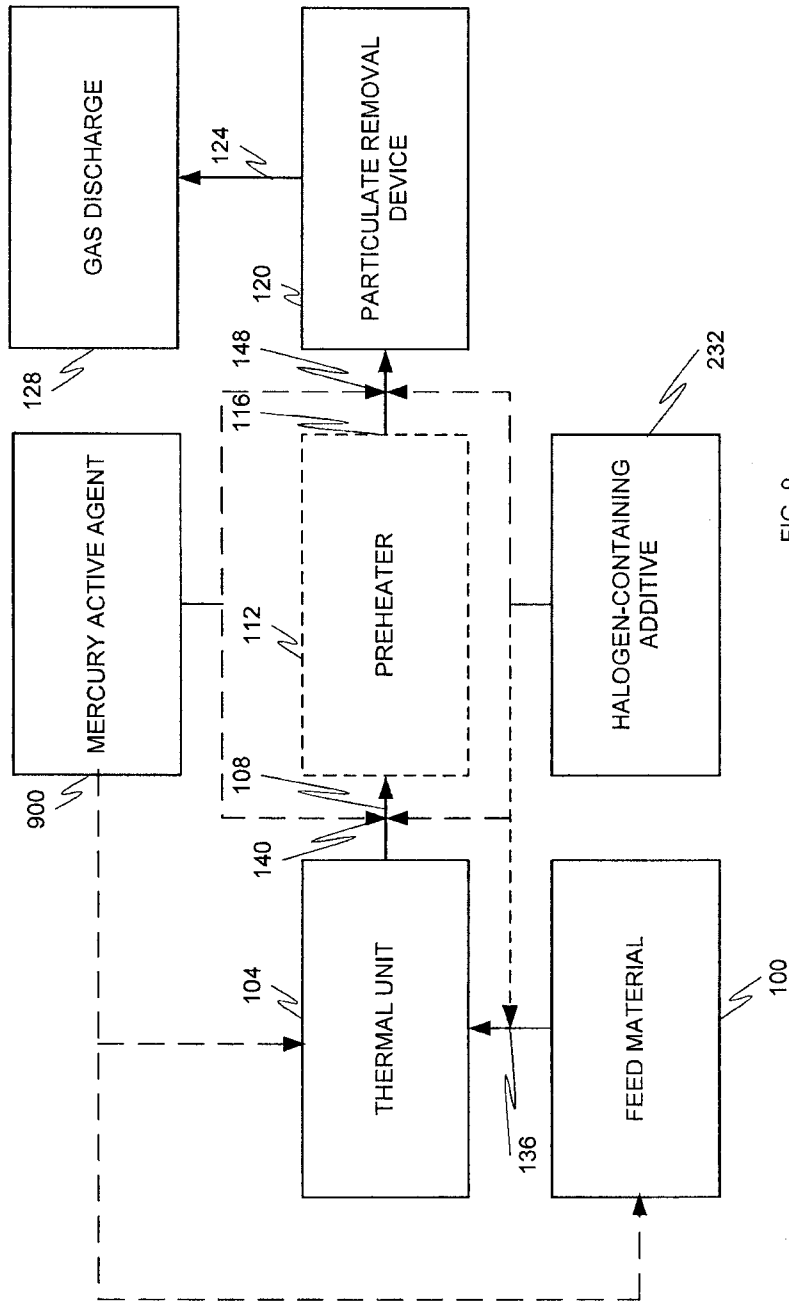

FIG. 9

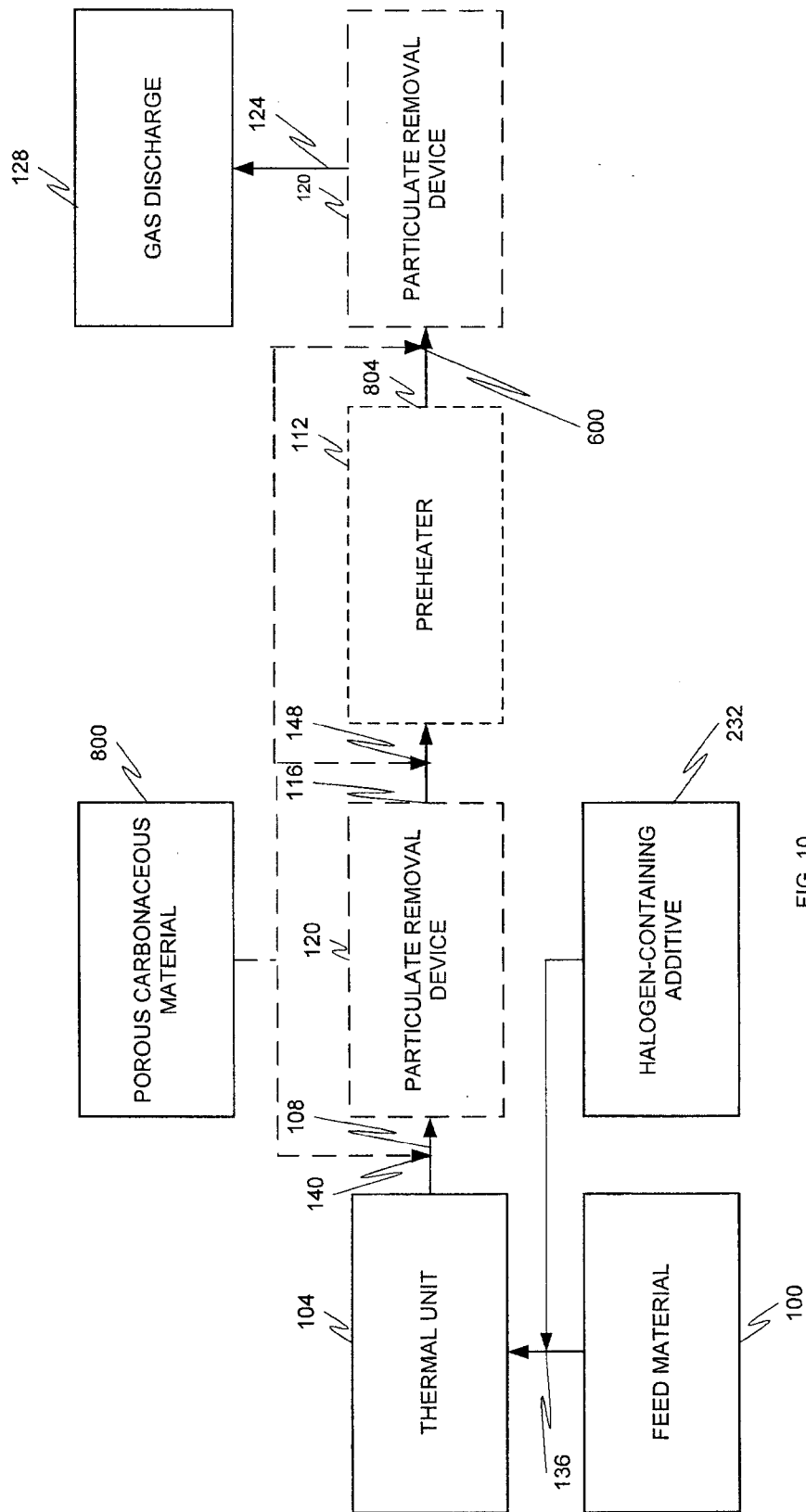

FIG. 10

