

(No Model.)

J. LUSSIER.

WRENCH.

No. 333,961.

Patented Jan. 5, 1886.

Fig. 1.

Fig. 2.

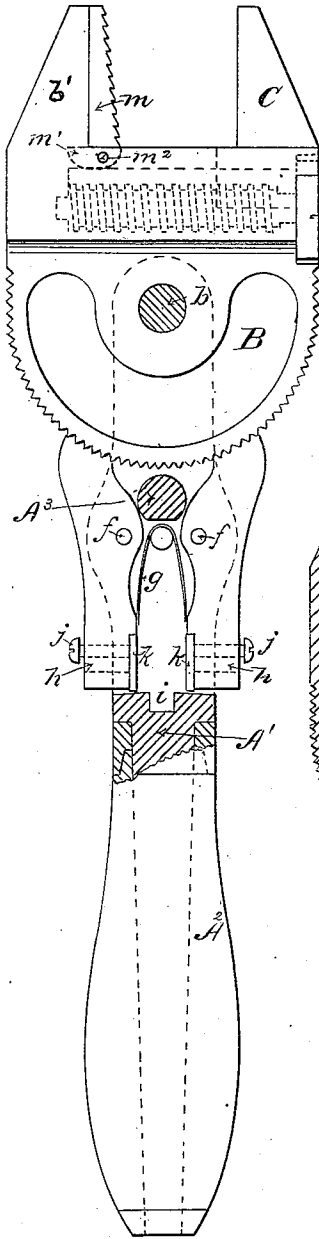
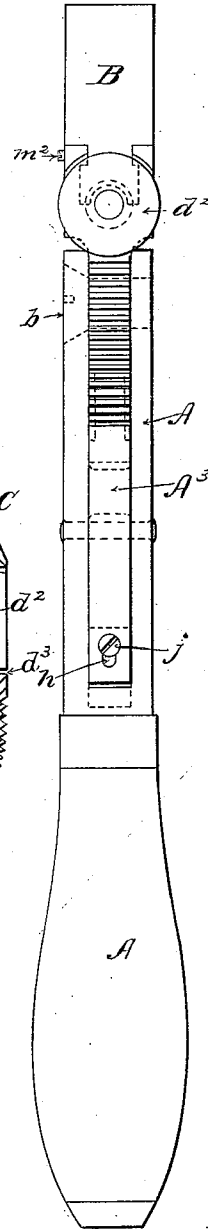
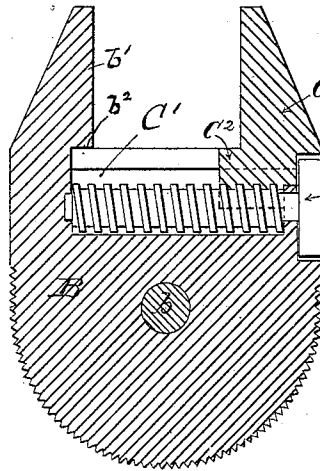

Fig. 3.



Witnesses
R. H. Sanford.
H. N. Peck

Inventor
Joseph Lussier
By Al Paul
Atty.

UNITED STATES PATENT OFFICE.

JOSEPH LUSSIER, OF MINNEAPOLIS, MINNESOTA, ASSIGNOR OF ONE-HALF
TO WILBUR F. WILLIAMS, OF SAME PLACE.

WRENCH.

SPECIFICATION forming part of Letters Patent No. 333,961, dated January 5, 1886.

Application filed April 9, 1885. Serial No. 161,760. (No model.)

To all whom it may concern:

Be it known that I, JOSEPH LUSSIER, a citizen of the United States, residing at Minneapolis, in the county of Hennepin and State of Minnesota, have invented a new and Improved Combination Rotary Wrench, of which the following is a specification.

The object of my invention is to furnish a wrench that can be used in corners and other hardly-accessible places where it is inconvenient or impossible to use an ordinary wrench; also to provide a wrench that may be readily adapted for use either as a pipe-wrench or as a nut-wrench.

My improvements relate to the class of wrenches having rocking or adjustable heads; and my invention consists in the construction and combination hereinafter described, and particularly pointed out in the claims.

In the accompanying drawings, forming part of this specification, Figure 1 is a side view of the wrench, a portion of the shank being in section. Fig. 2 is a face view. Fig. 3 is a section of the head, showing the operating-screw and the sliding jaw.

A is the main body of the wrench, which is provided with the shank A', and is secured in the wooden handle A'' in any suitably manner. The upper part of the body is open to receive within it the head of the wrench and the pawls or dogs hereinafter described. Between the two parts of the body is the stay or stud A³, which is formed integral with the body, as shown in Figs. 1 and 2. The upper part of the body forms a fork, and each side is provided with a perforation, one of which is screw-threaded to receive the threaded end of a screw. (Shown in dotted lines at *b*, Fig. 2.)

B is the head of the wrench, which is pivoted within the body A upon the screw *b*. The part of the head below the operating-screw is circular, and its edge is toothed or serrated in order that it may be engaged by the ends of dogs or pawls *e e*, which serve to hold the head securely in place as adjusted. These dogs are pivoted in the body A on pins *f f* at opposite sides of the body, and are pressed into contact with the head by a spring, *g*. The lower ends of the dogs extend outside the

body or handle, so that either or both may be quickly and readily disconnected by the hand of the operator grasping the tool. This allows a quick adjustment of the head and re-engagement of the dogs. Each dog has an opening, *h*, through its lower part, and through this extends the screw-pin *j*, having upon its inner end the catch *k*. A recess, *i*, is formed within the body, and when either dog is pressed in against the spring *g* the catch *k* may be made to engage in the recess *i*, and the pawl will then be held with its serrated end out of connection with the head B. The body A and the upper part of the head B are of the same thickness, while the lower part of the head is of less thickness, so that it may fit within the fork formed by the two sides of the body. The upper part of the head B is cut away to form a fixed jaw, *b'*, and is recessed at *c'*, as shown in Fig. 3, to receive the tongue of the movable jaw and the operating-screw *d*. The operating-screw has on its end a milled wheel, *d'*, which fits within a recess, *d''*, in the head B, with its edges extending slightly beyond the side faces of the head, as shown in Fig. 2. The recess *c'* extends beyond the face of the fixed jaw, as shown in Fig. 3, and thereby forming the shoulder *b''* under the fixed jaw. The tongue of the jaw *c* extends beyond the face of the jaw, as shown at *c''*, thereby forming a long bearing for this jaw on the screw *d* and within the recess *c'*. When the movable jaw is brought close to the fixed jaw, this extension moves under the shoulder *b''* of the fixed jaw *b'*.

In order to adapt this wrench for use as a pipe-wrench, I provide the detachable serrated jaw face *m*, as shown in Fig. 1. The back surface of this detachable jaw *m* is smooth and adapted to fit the face of the fixed jaw *b'*, and at its lower end it is provided with the rearwardly-projecting lug *m'*, constructed to fit closely under the shoulder *b''* of jaw *b'*. A set-screw, *m''*, is provided in head B to hold jaw *m* securely in place. By this construction this wrench, which is adapted for use as a nut or bolt wrench, may be readily converted into a pipe-wrench.

The tool herein described is an improvement on that secured to me by Letters Patent

No. 308,969, dated December 9, 1884, and, except as herein specified, the construction is that described in said patent.

I claim as my invention—

1. The combination, in a wrench, with the rotary head B, provided with fixed jaw *b'* and movable jaw *c*, of the pivoted pawls *e e*, having openings *h*, the pins *j*, catches *k*, recess *i*, and spring *g*, substantially as described.

2. The combination, in a wrench, with the rotary head B, having the recess *c'*, fixed jaw

b', and shoulder *b²*, of the serrated jaw-face *m*, having lug *m'*, the set-screw *m²*, the movable jaw *c*, and operating-screw *d*, substantially as described.

JOSEPH ^{his} × LUSSIER.
mark.

Witnesses:

A. C. PAUL,

JAS. E. WOODFORD.