



US0D1014710S

(12) **United States Design Patent**
Knecht et al.

(10) **Patent No.:** **US D1,014,710 S**

(45) **Date of Patent:** **** Feb. 13, 2024**

(54) **CONNECTOR FOR A DEVICE FOR DISTRIBUTING LIQUIDS**

(71) Applicant: **Robatech AG**, Muri (CH)

(72) Inventors: **Stephan Knecht**, Oberwil-Lieli (CH);
Markus Sennrich, Rombach (CH)

(73) Assignee: **ROBATECH AG**, Muri (CH)

(**) Term: **15 Years**

(21) Appl. No.: **29/773,667**

(22) Filed: **Mar. 11, 2021**

(30) **Foreign Application Priority Data**

Sep. 11, 2020 (EM) 008167837-0002

(51) **LOC (14) CL.** **23-01**

(52) **U.S. CL.**
USPC **D23/262**

(58) **Field of Classification Search**
USPC D23/213, 233, 235, 249, 259, 262-263,
D23/266
CPC F16L 37/32; F16L 37/367; F16L 37/373;
F16L 37/28; F16L 37/30; F16L 37/38;
F16L 37/40; F16L 37/44; F16L 37/46;
F16L 37/47; F16L 37/48; F16K 21/165;
F16K 21/16; F16K 21/14; F16K 21/06;
F16K 21/04; F16K 21/00; F16K 23/00;
F16K 17/383

See application file for complete search history.

(56) **References Cited**

U.S. PATENT DOCUMENTS

D434,834 S *	12/2000	Goto	D23/262
D442,267 S *	5/2001	Kouda	D23/262
D471,262 S *	3/2003	Kozu	D23/262
6,540,263 B1 *	4/2003	Sausner	F16L 37/144 285/308
D482,761 S *	11/2003	Gotoh	D23/262
D520,123 S *	5/2006	Kitagawa	D23/262

D608,424 S *	1/2010	Katsuta	D23/266
D639,398 S *	6/2011	Wilhelm	D23/262
D642,244 S *	7/2011	Wilhelm	D23/262
D788,890 S *	6/2017	Downs	F16L 37/0841 D23/262
D830,524 S *	10/2018	Vranish	D23/262
D834,689 S *	11/2018	Fujiwara	D23/263
D896,930 S *	9/2020	Vranish	D23/262
D928,925 S *	8/2021	Lei	D23/262
D960,331 S *	8/2022	Yen	D23/262

FOREIGN PATENT DOCUMENTS

EM 008167837 * 4/2021

* cited by examiner

Primary Examiner — Karen S Acker

Assistant Examiner — Andrea Marie McKay

(74) *Attorney, Agent, or Firm* — CHRISTOPHER C. DREMANN, P.C.; Christopher C. Dremann

(57) **CLAIM**

The ornamental design for a connector for a device for distributing liquids, as shown and described.

DESCRIPTION

FIG. 1 is a perspective view of a connector for a device for distributing liquids according to our design; FIG. 2 is a right side view of the connector of FIG. 1; FIG. 3 is a left side view of the connector of FIG. 1 being opposite to the right side view; FIG. 4 is a front view of the connector of FIG. 1; FIG. 5 is a rear view of the connector of FIG. 1; FIG. 6 is a top view of the connector of FIG. 1; and, FIG. 7 is a bottom view of the connector of FIG. 1. The broken lines in the drawings depict portions of the connector for a device for distributing liquids that form no part of the claimed design.

1 Claim, 6 Drawing Sheets

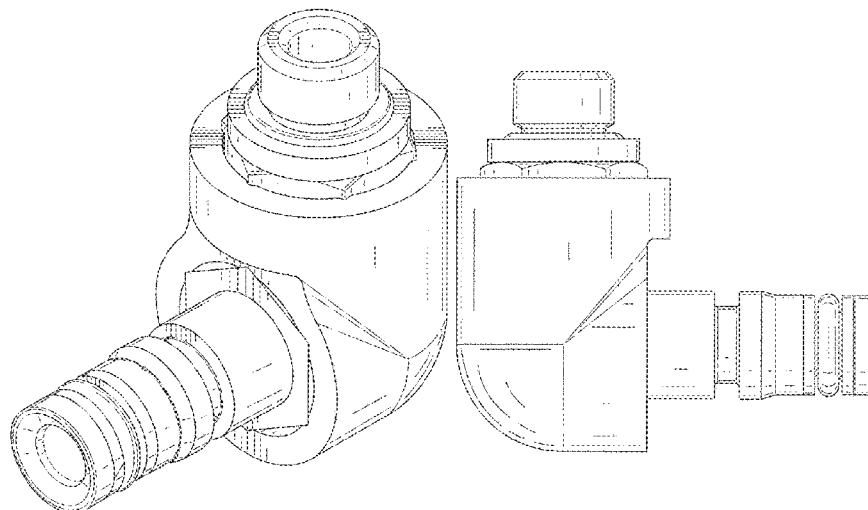

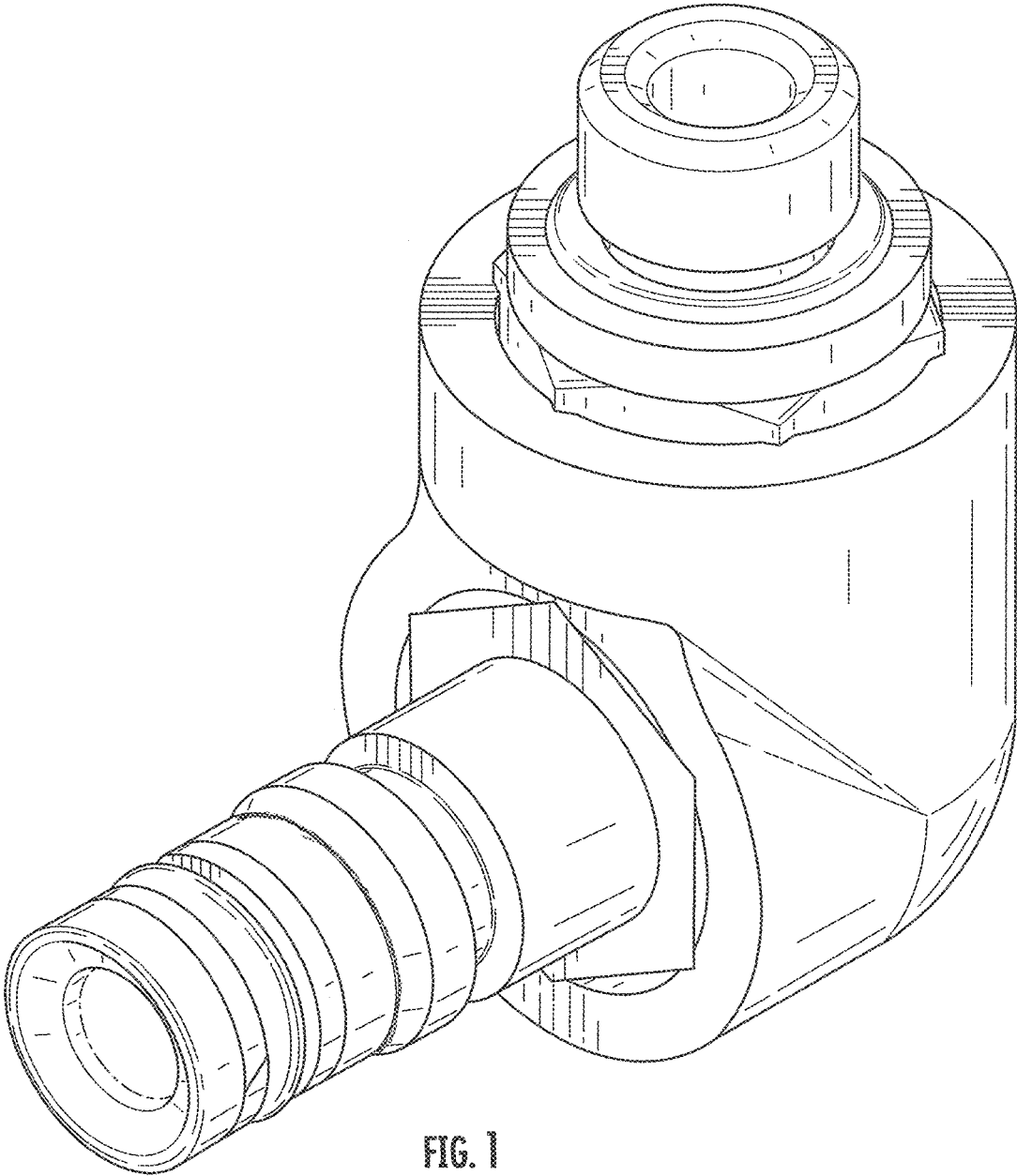

FIG. 1

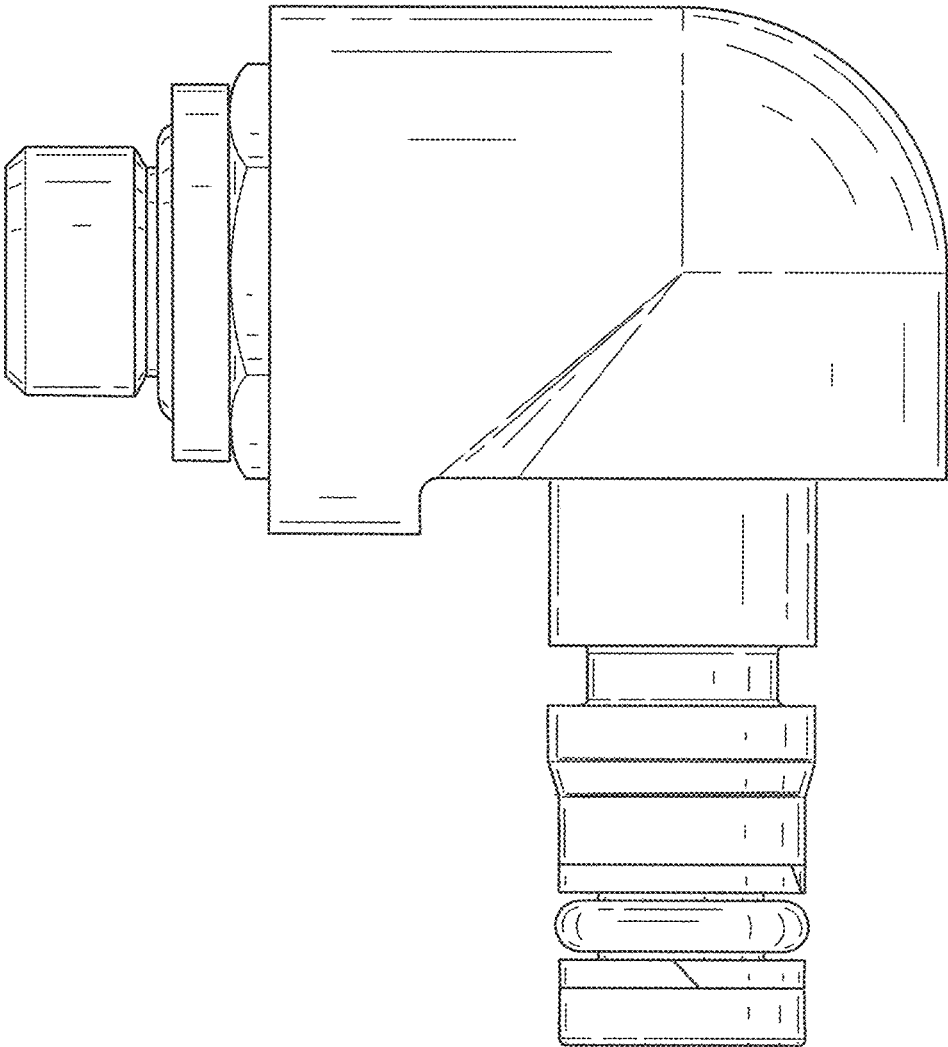

FIG. 2

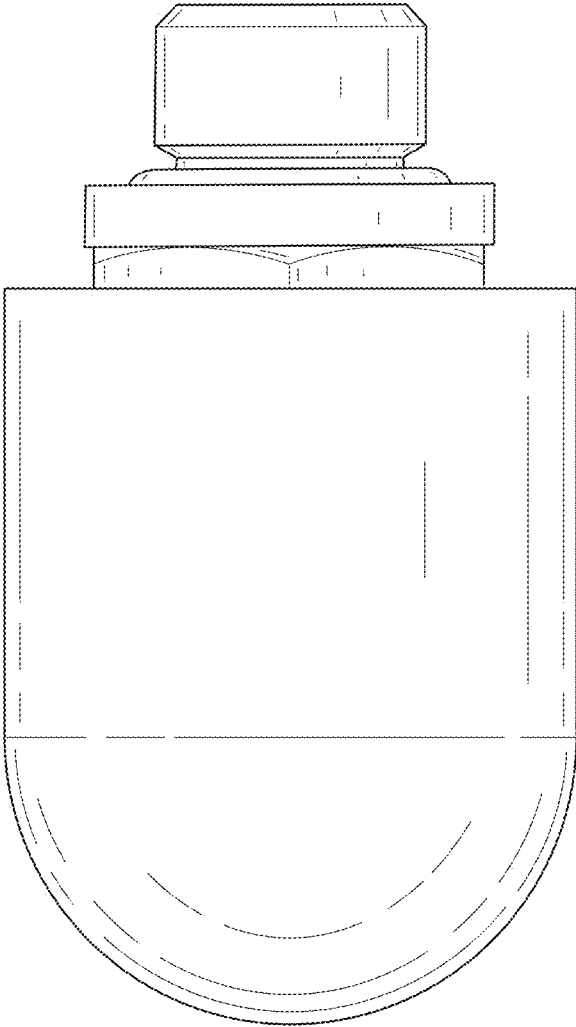

FIG. 4

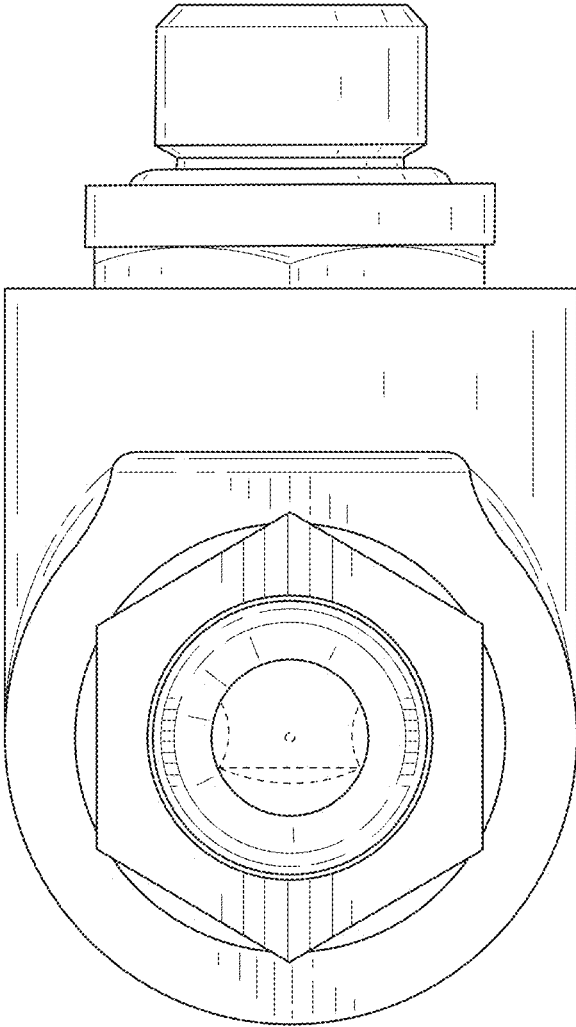

FIG. 5

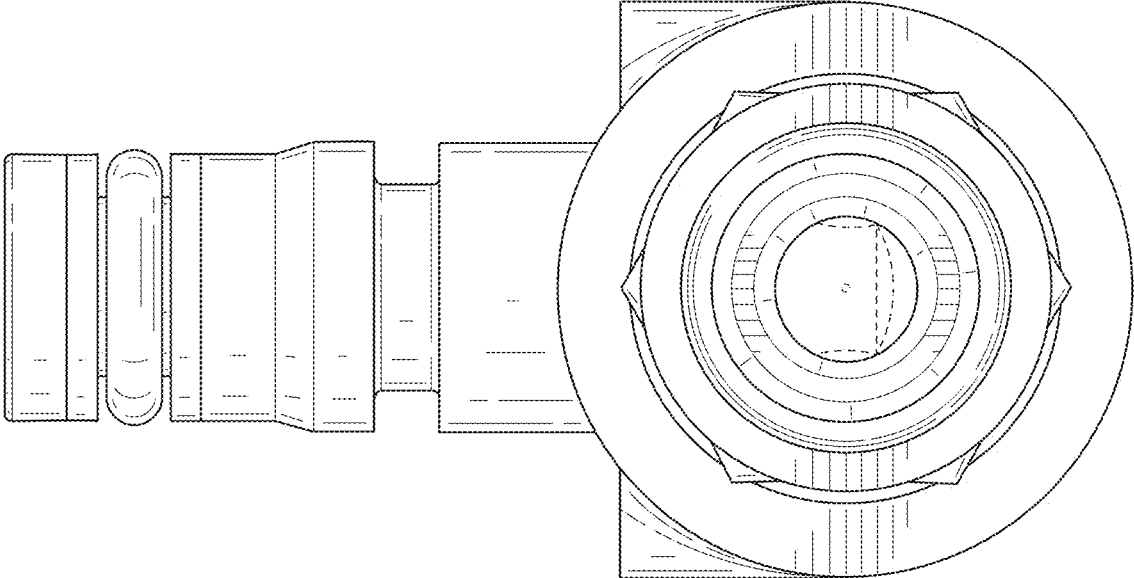

FIG. 6

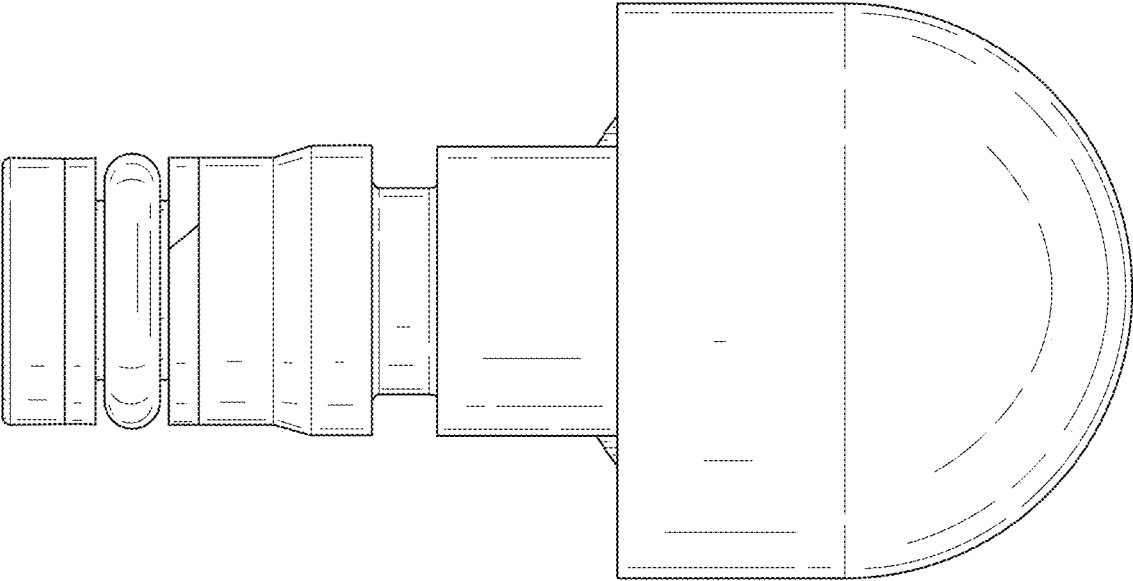

FIG. 7