



US00D914769S

(12) **United States Design Patent**
Marini

(10) **Patent No.:** **US D914,769 S**

(45) **Date of Patent:** **** Mar. 30, 2021**

(54) **TIRE SEALING AND INFLATION DEVICE**

Primary Examiner — Eliza Z Bennett-Hattan

(71) Applicant: **TEK GLOBAL S.R.L.**, Pesaro (IT)

(74) *Attorney, Agent, or Firm* — Leason Ellis LLP

(72) Inventor: **Maurizio Marini**, Pesaro (IT)

(73) Assignee: **TEK GLOBAL S.R.L.**, Pesaro (IT)

(57) **CLAIM**

(**) Term: **15 Years**

The ornamental design for the tire sealing and inflation device, as shown and described.

(21) Appl. No.: **35/506,986**

(22) Filed: **Nov. 30, 2018**

DESCRIPTION

(80) **Hague Agreement Data**

Int. Filing Date: **Nov. 30, 2018**

Tire sealing and inflation device

Int. Reg. No.: **DM/201422**

FIG. 1.1 is a top perspective view of a tire sealing and inflation device, showing a first embodiment;

Int. Reg. Date: **Nov. 30, 2018**

FIG. 1.2 is a right lateral view;

Int. Reg. Pub. Date: **Jun. 28, 2019**

FIG. 1.3 is a left lateral view;

(51) **LOC (13) Cl.** **15-02**

FIG. 1.4 is a front elevation view;

(52) **U.S. Cl.**

FIG. 1.5 is a rear view;

USPC **D15/7**

FIG. 1.6 is a top plan view;

(58) **Field of Classification Search**

FIG. 1.7 is a bottom plan view;

USPC D15/7, 9, 199; D8/31

FIG. 2.1 is a top perspective view of a tire sealing and inflation device, showing a second embodiment;

CPC B29C 73/025; B29C 73/166; B60S 5/046

FIG. 2.2 is a right lateral view;

See application file for complete search history.

FIG. 2.3 is a left lateral view;

(56) **References Cited**

FIG. 2.4 is a front elevation view;

U.S. PATENT DOCUMENTS

FIG. 2.5 is a rear view;

D599,389 S * 9/2009 Eckhardt D15/199

FIG. 2.6 is a top plan view; and

D613,320 S * 4/2010 Marini D15/199

FIG. 2.7 is a bottom plan view.

D631,494 S * 1/2011 Marini D15/199

The present application relates to a tire sealing and inflation device in which the broken line shown is for the purpose of illustrating portions which forms no part of the claimed designs and wherein: figure 1.1 is a top perspective view of the device according to a first design; figure 1.2 to figure 1.7 are respectively a right lateral, left lateral, front, rear, top and bottom views of the design of figure 1.1; same typology of views are provided for figure 2.1-2.7.

D645,056 S * 9/2011 Marini D15/9

The broken-line showing of portions of the tire sealing and inflation device is included for the purpose of illustrating environmental structure and forms no part of the claimed design.

D657,383 S * 4/2012 Wang D15/7

D842,354 S * 3/2019 Marini D15/199

D873,863 S * 1/2020 Marini D15/7

2008/0029181 A1* 2/2008 Marini B29C 73/025

141/38

2008/0277044 A1* 11/2008 Marini B29C 73/166

156/97

2009/0266440 A1* 10/2009 Lolli B60S 5/043

141/38

2011/0116941 A1* 5/2011 Lolli B29C 73/166

417/313

(Continued)

1 Claim, 14 Drawing Sheets

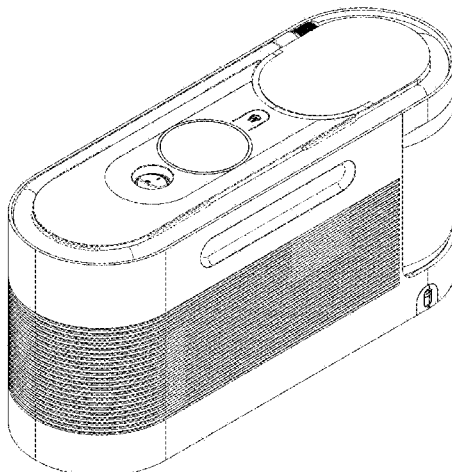

(56)

References Cited

U.S. PATENT DOCUMENTS

2011/0180180	A1*	7/2011	Lolli	B29C 73/166
				141/38
2016/0126765	A1*	5/2016	Marini	H02J 7/007192
				320/107

* cited by examiner

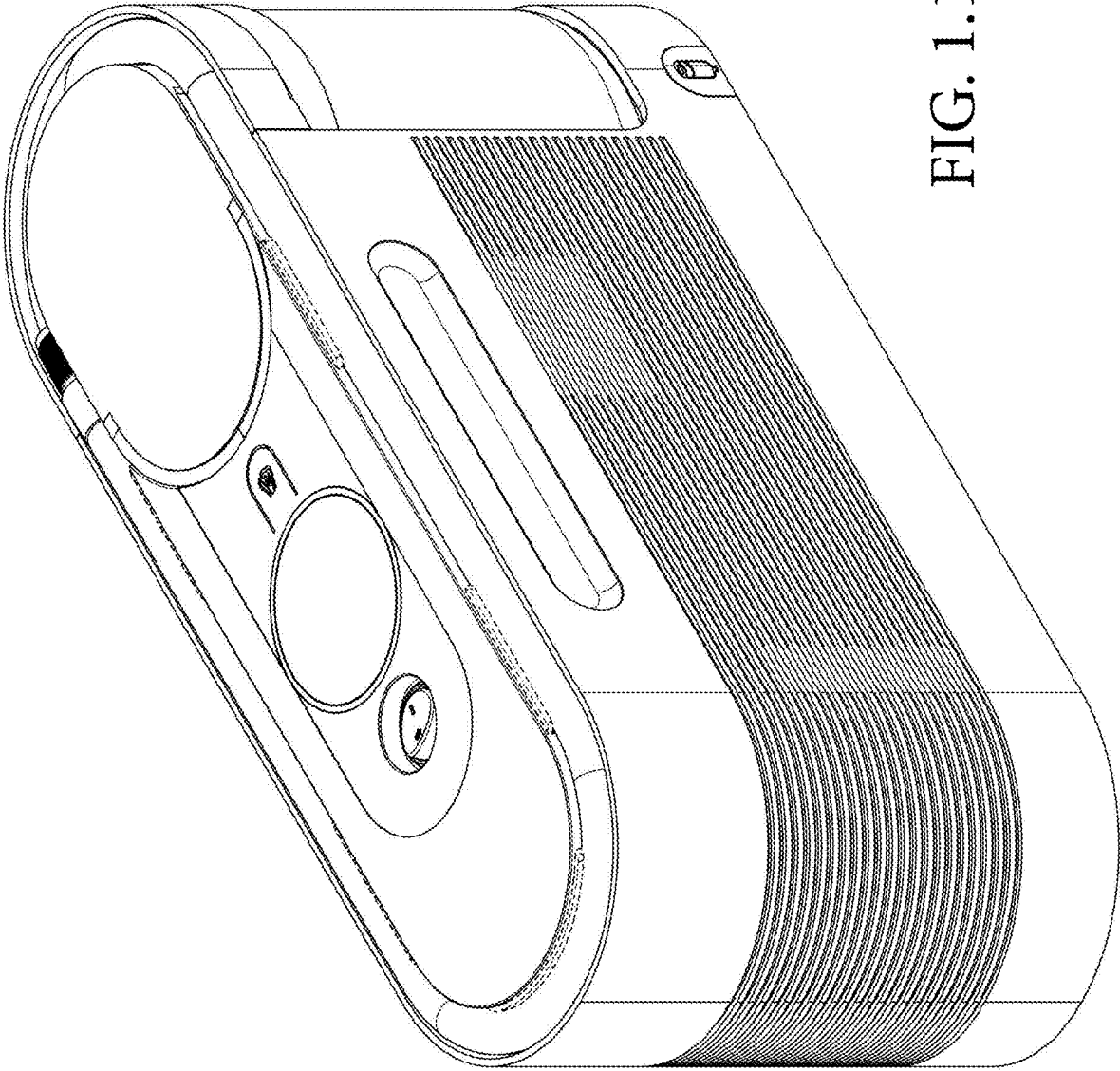

FIG. 1.1

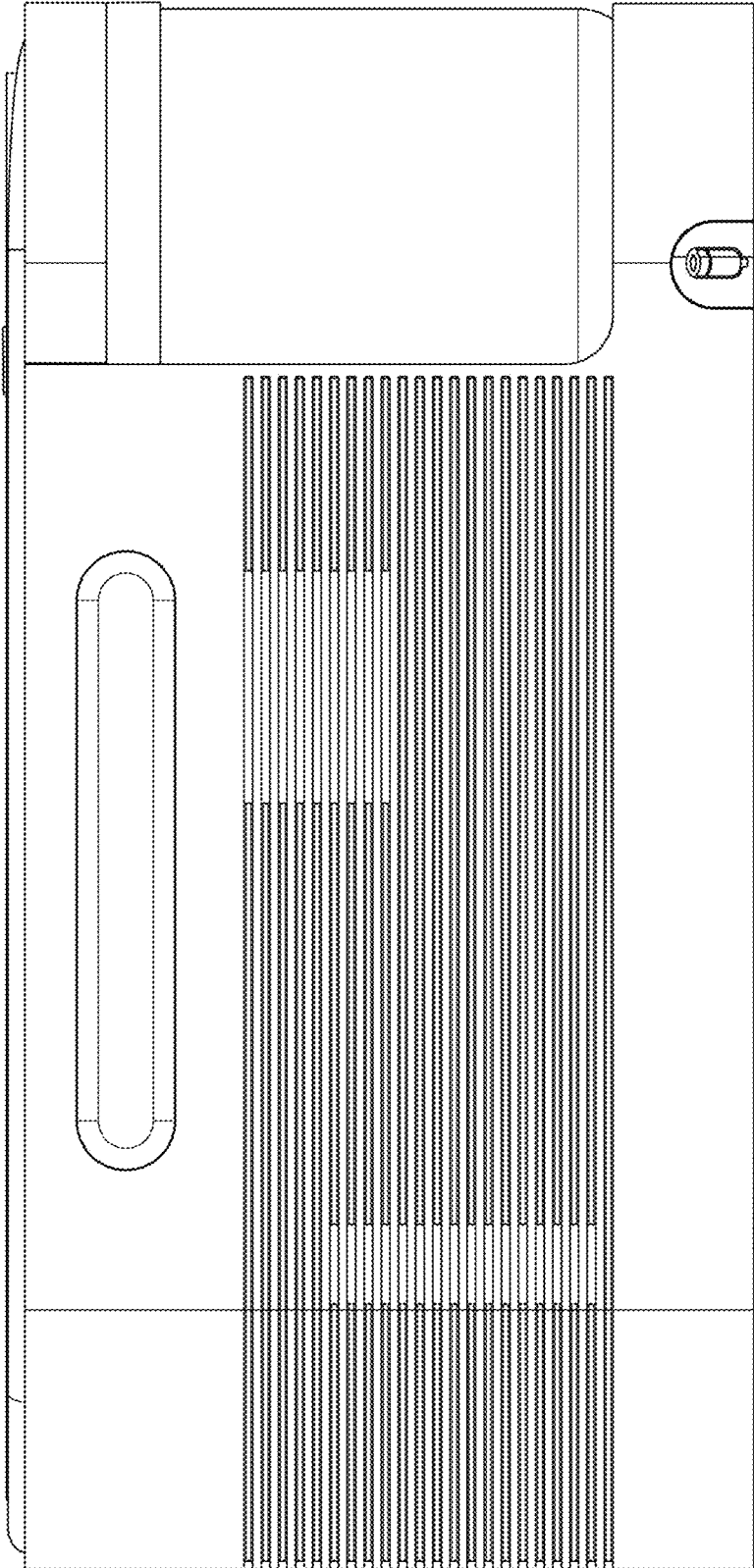

FIG. 1.2

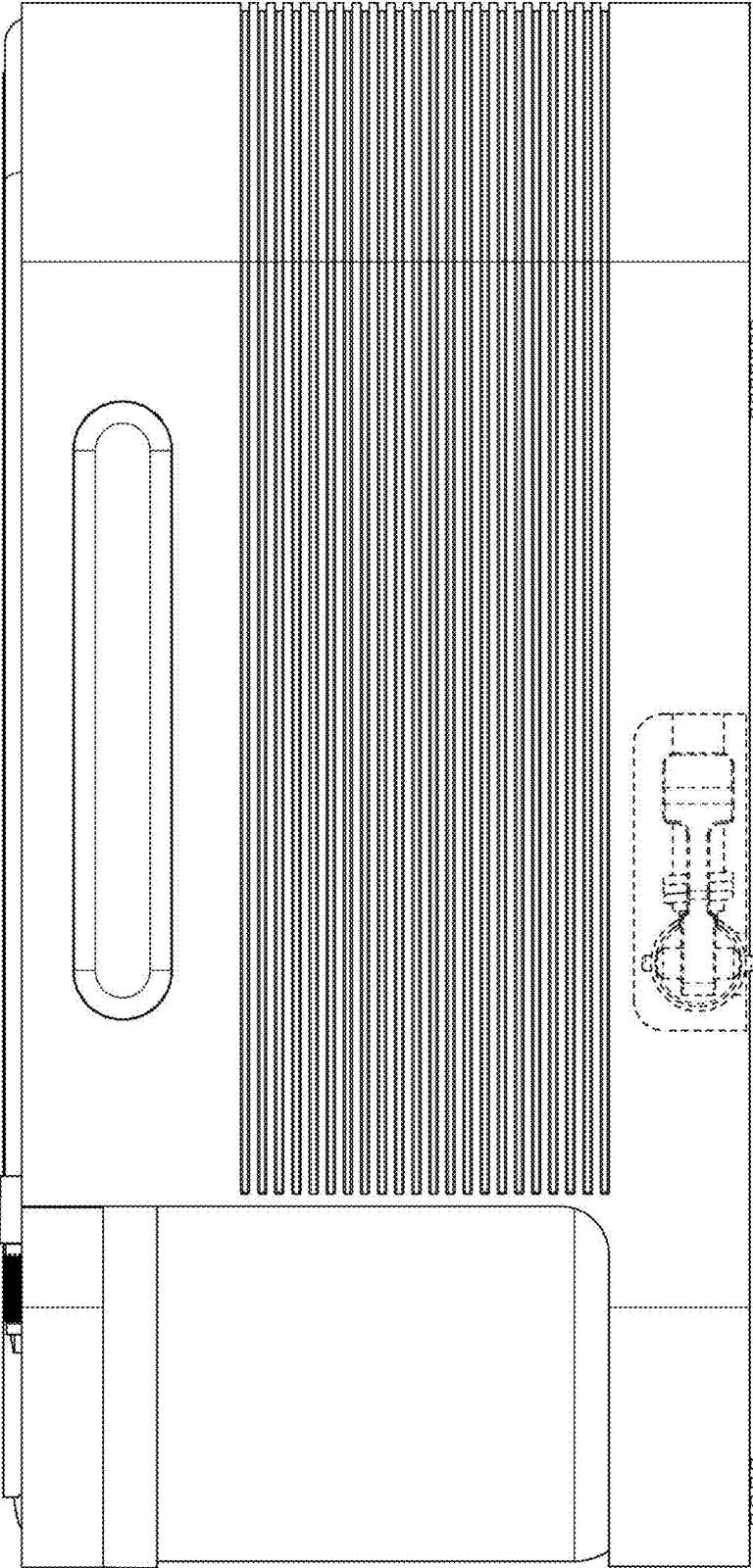

FIG. 1.3

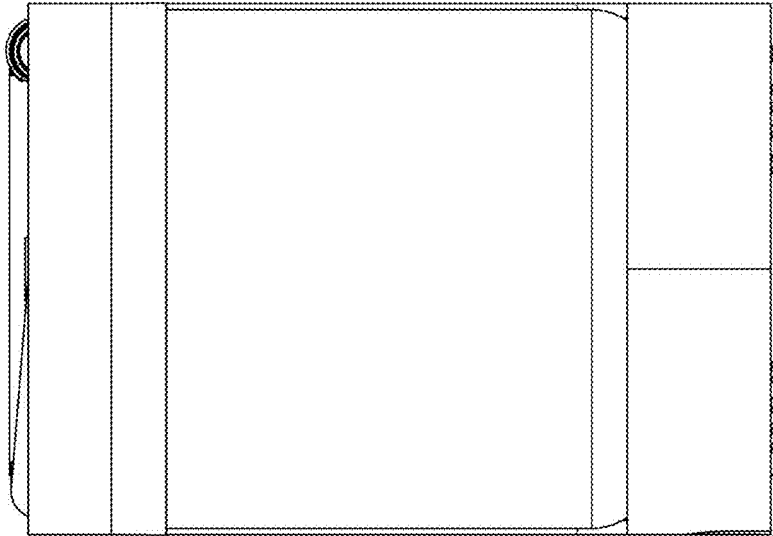

FIG. 1.4

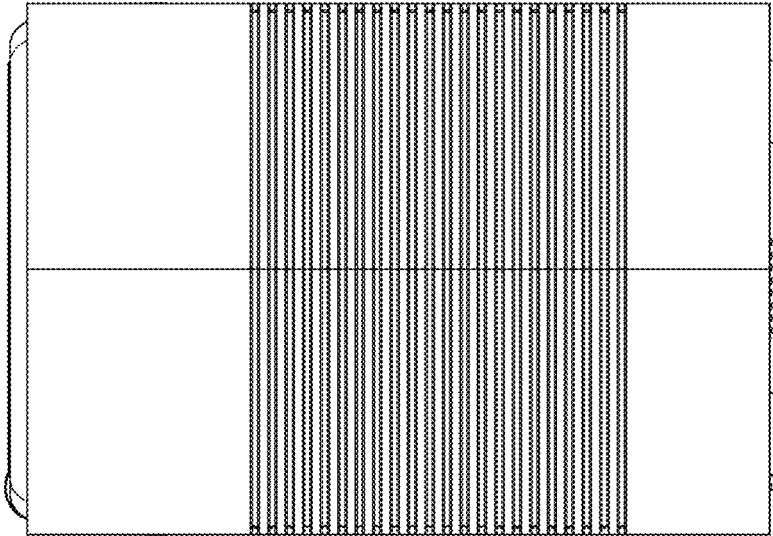

FIG. 1.5

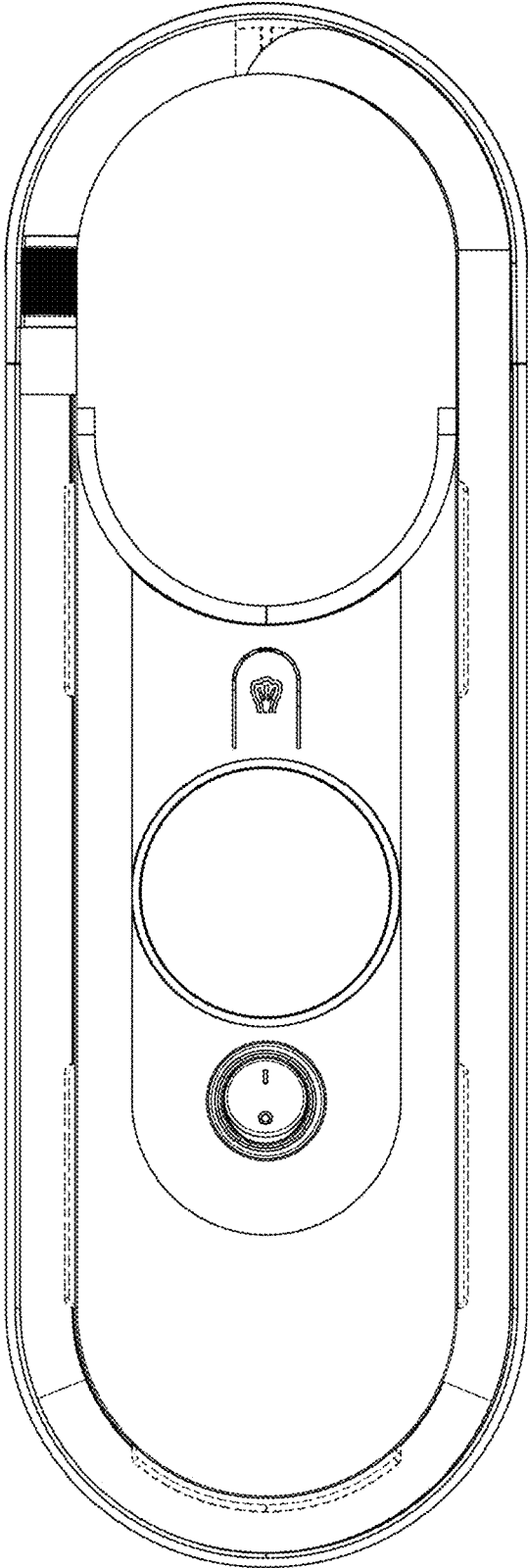

FIG. 1.6

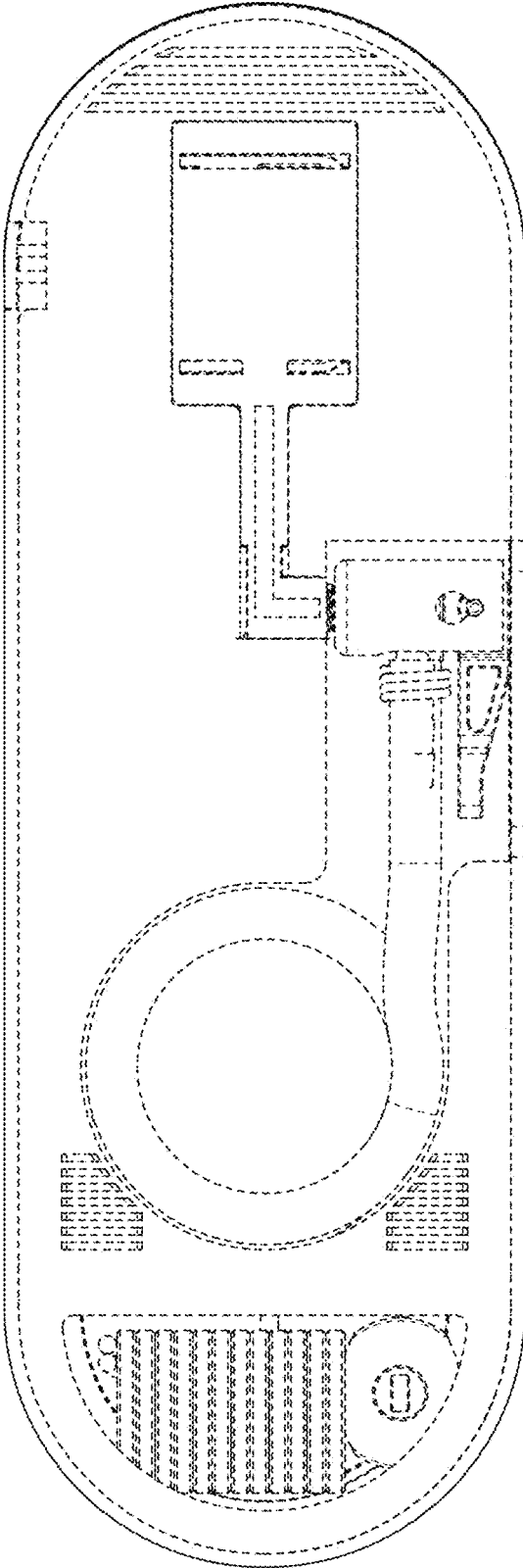

FIG. 1.7

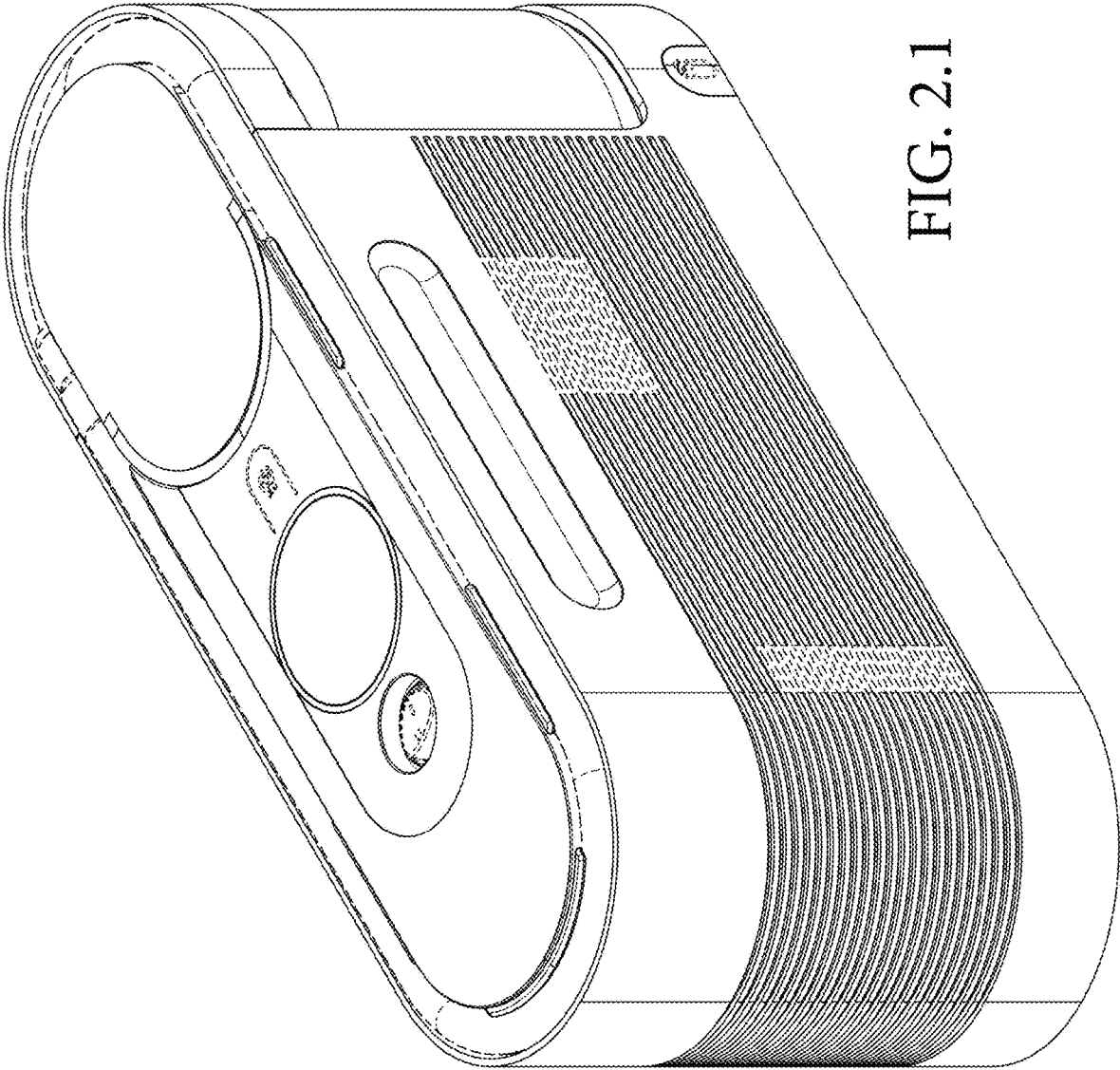

FIG. 2.1

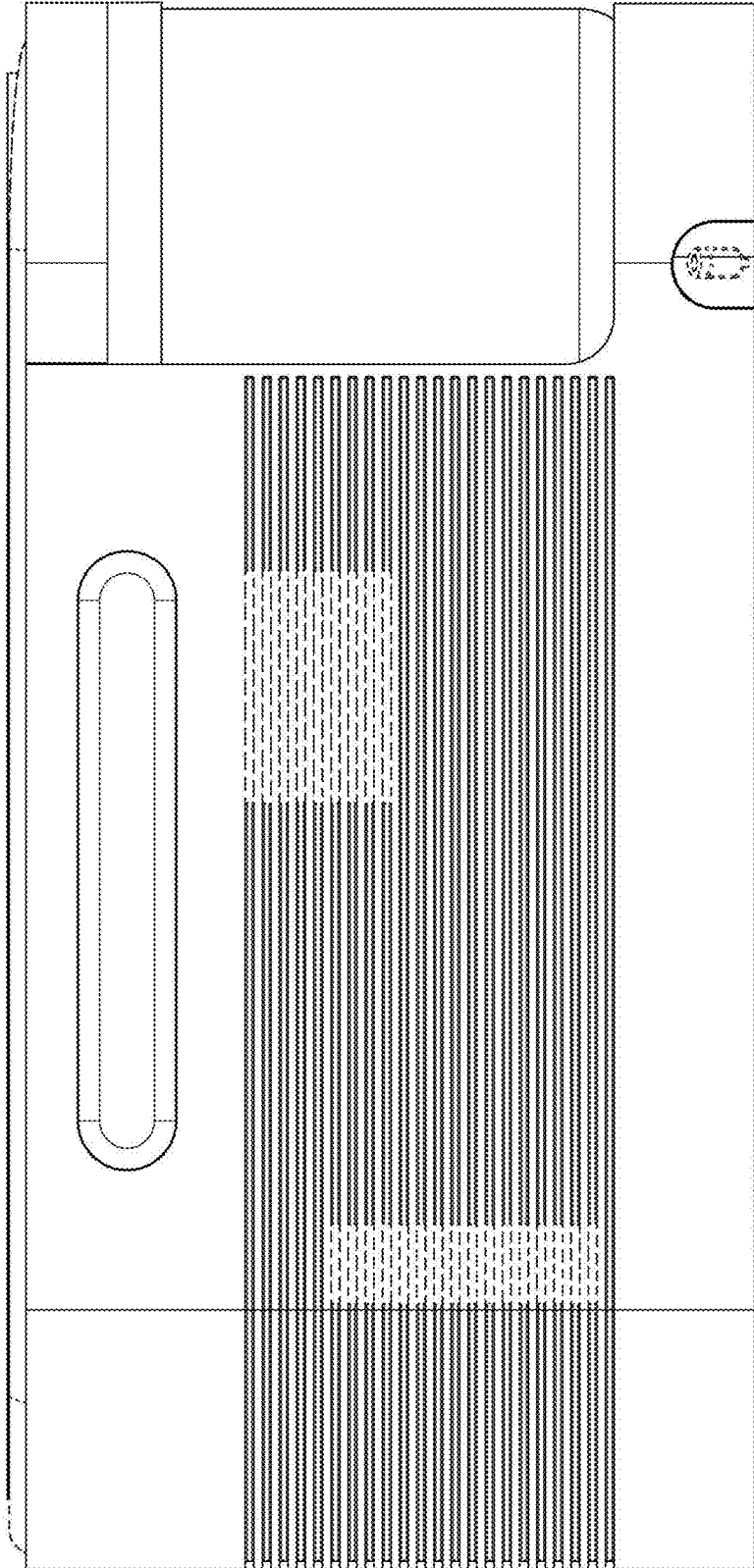

FIG. 2.2

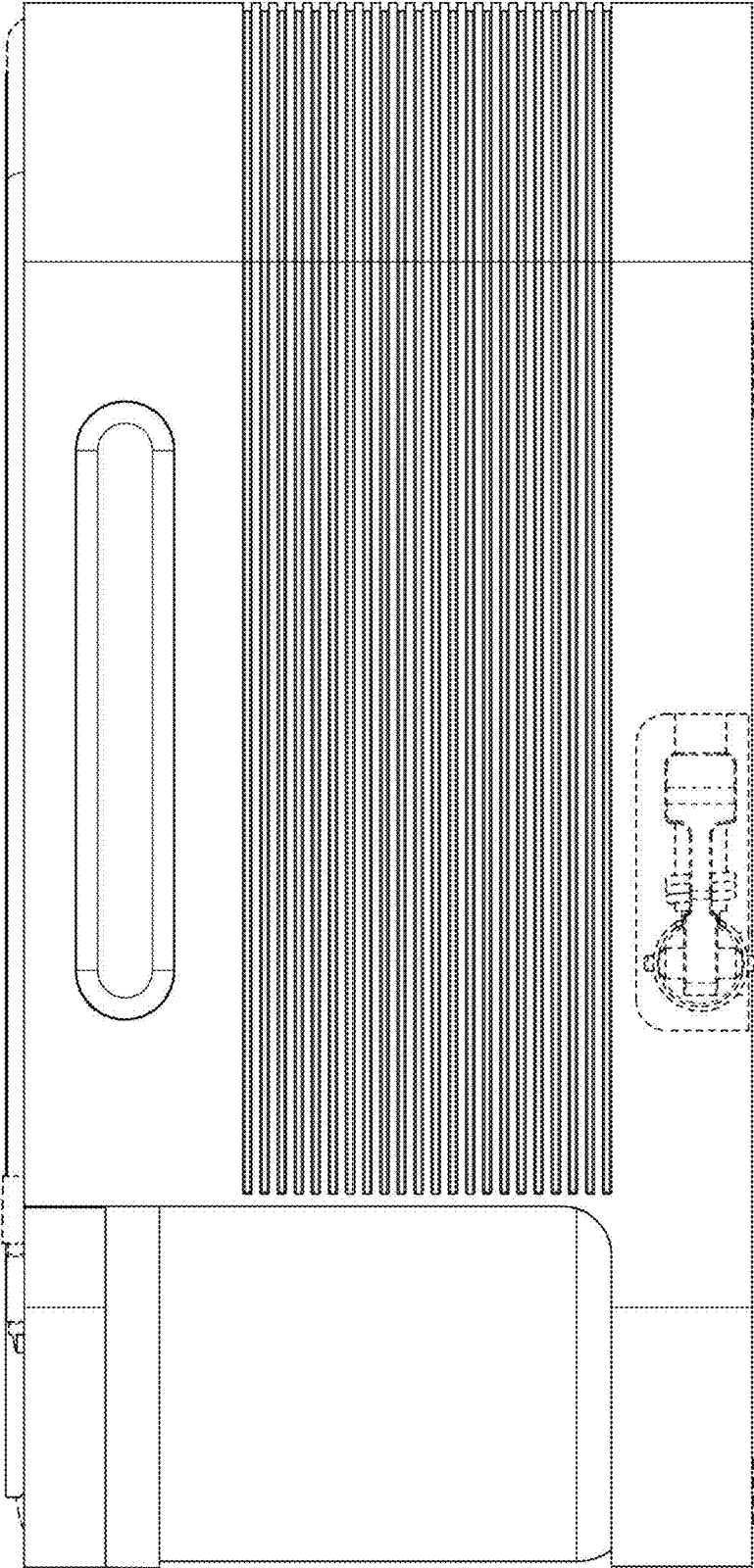

FIG. 2.3

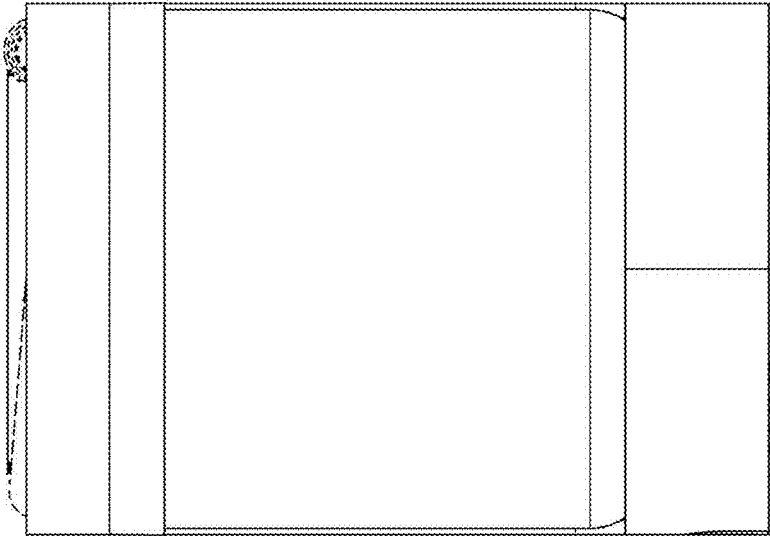

FIG. 2.4

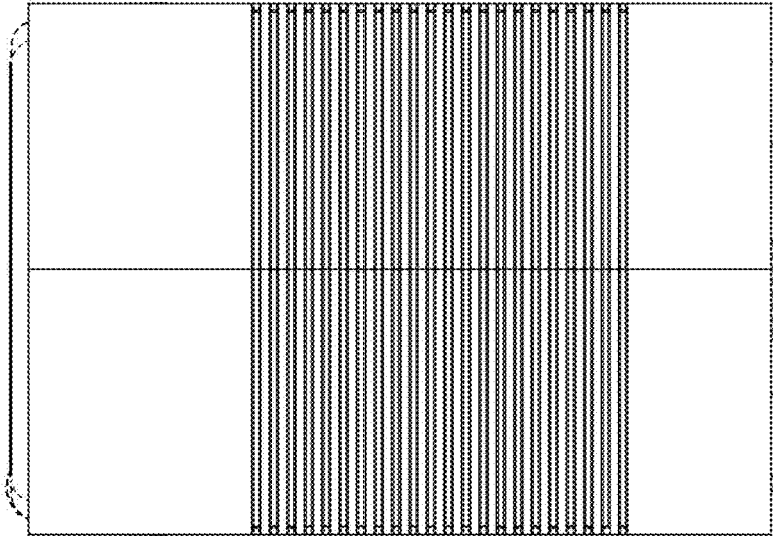

FIG. 2.5

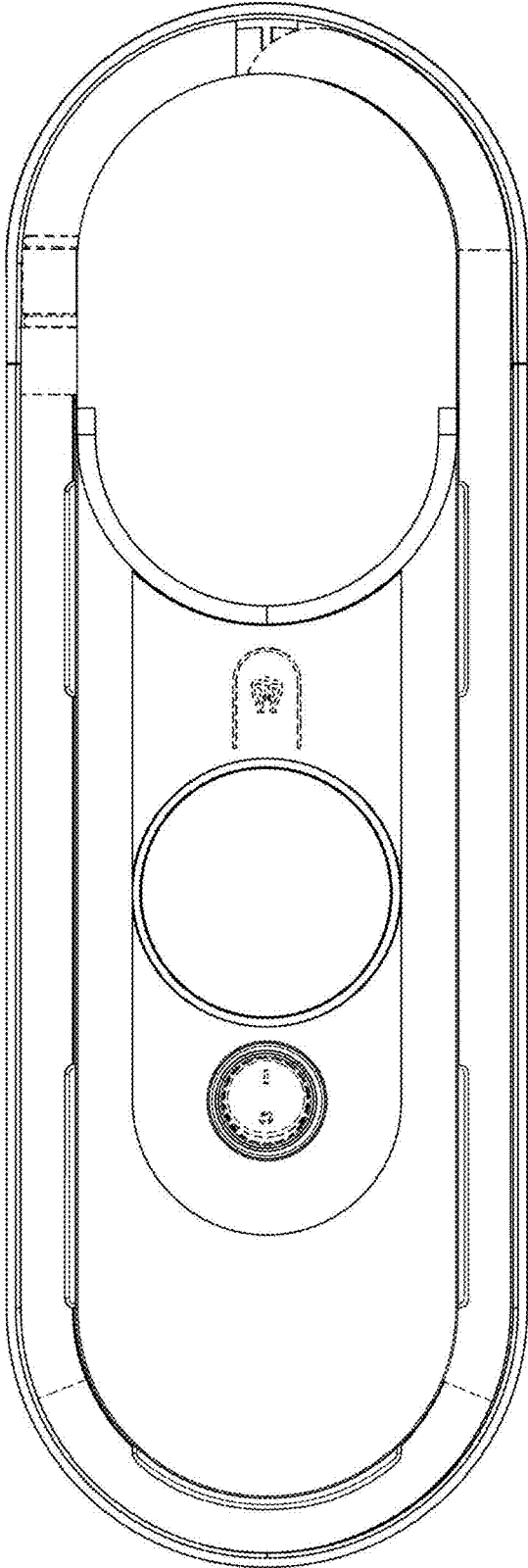

FIG. 2.6

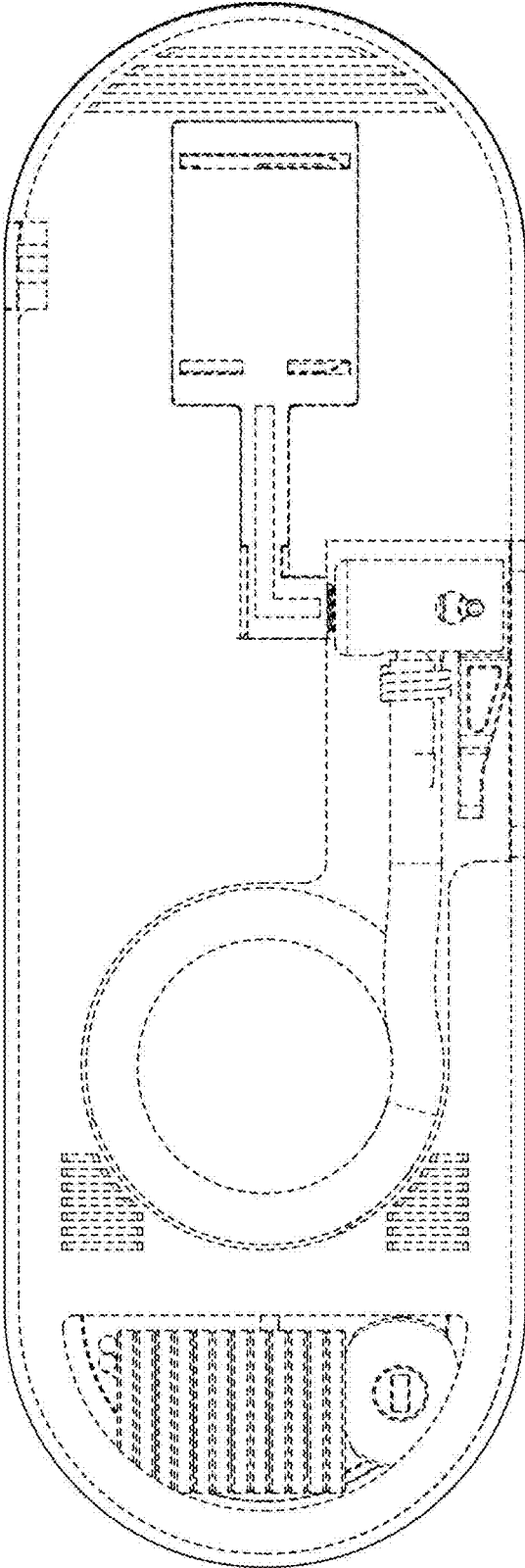

FIG. 2.7