

(12) **UK Patent Application** (19) **GB** (11) **2 211 196** (13) **A**
(43) Date of A publication 28.06.1989

(21) Application No 8829277.6

(22) Date of filing 15.12.1988

(30) Priority data

(31) 62320565 (32) 17.12.1987 (33) JP

(71) Applicants

Nippon Gohsei Kagaku Kogyo Kabushiki Kaisha

(Incorporated in Japan)

9-6 Nozaki-cho, Kita-ku, Osaka-shi, Osaka 530, Japan

Nichigo Film Kabushiki Kaisha

(Incorporated in Japan)

80, Kamiya 2-chome, Ogaki-shi, Gifu 503, Japan

(72) Inventors

Tsukasa Oishi

Toshio Marui

(74) Agent and/or Address for Service

Brookes and Martin

**High Holborn House, 52/54 High Holborn, London,
WC1V 6SE, United Kingdom**

(51) INT CL⁴

A61F 5/44 5/445, B65D 30/02

(52) UK CL (Edition J)

C3V VET

B8K KWC

C3J JAJ

U1S S1050 S1067

(56) Documents cited

EP 0199358 A2

(58) Field of search

UK CL (Edition J) C3J JAJ, C3V VEF VEH VET

(54) **Articles for collecting waste body products**

(57) A container particularly suited for use as a bag for collecting waste matter discharged through an artificial anus is essentially made of a single-layer or multilayer packaging material comprising an oxyalkylene group-containing vinyl alcohol copolymer film layer.

GB 2 211 196 A

2211196

Fig. 1

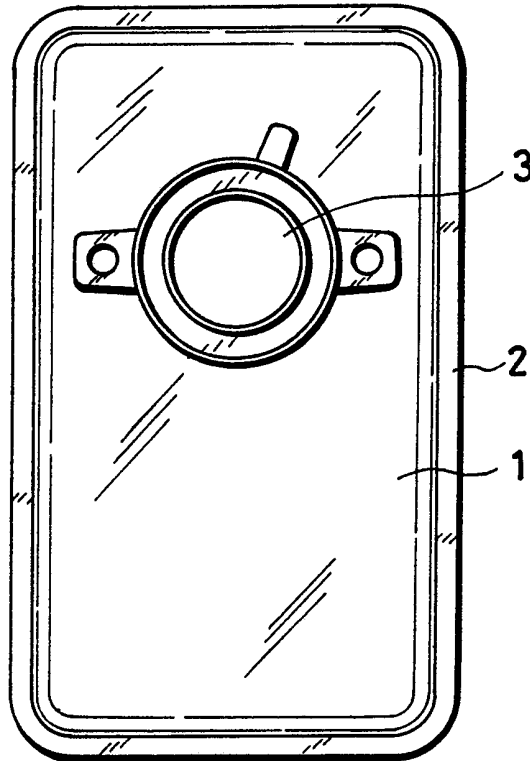
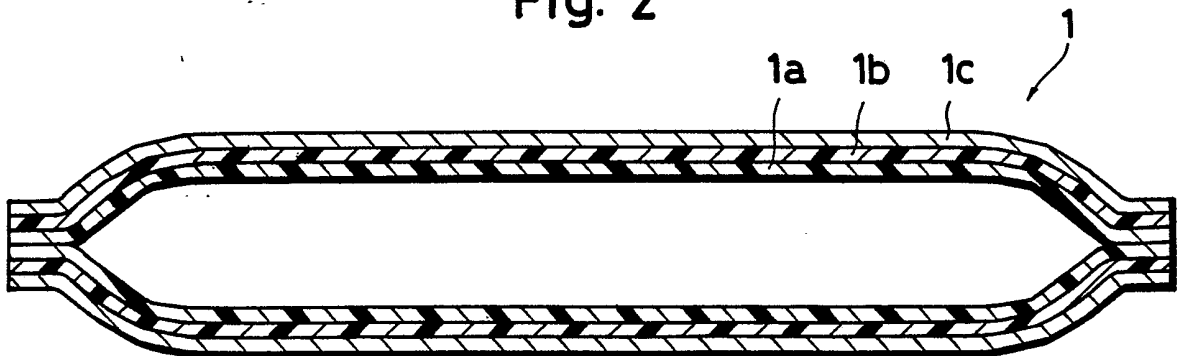
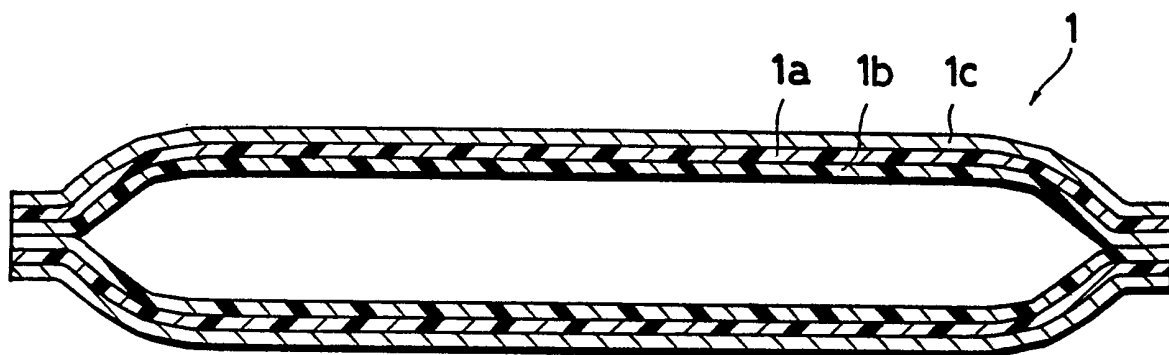

Fig. 2



2211196

Fig. 3



CONTAINERS FOR FILTHY MATTER

Background of the Invention

This invention relates to containers for filthy
5 waste matter, in particular bags for collecting excreta
from the artificial anus, which have good flexibility
and odor-retaining property and can be thrown into the
flush toilet bowl without causing troubles.

Immediately after operative treatment of diseases
10 of tubular or cavitary organs, such as ileum, transverse
colon, descending colon, sigmoid colon and anal fistula,
a minute opening (stoma), generally called an artificial
anus, is sometimes formed on the body surface for
discharge of filthy waste matter, such as fecal matter,
15 pus or body fluid, therethrough. Not only immediately
after operations but also during convalescence and even
after return to work, the artificial anus is retained
in many instances.

Bags for collecting the waste matter excreted from
20 the artificial anus are called ostomy bags, colostomy
bags, ileostomy bags and so forth depending of the
tubular or cavitary organ to which the stoma is connected.

As to the construction of bags of this kind,
various proposals have so far been made, as mentioned
25 below.

Japanese Kokai Jitsuyo-Shinan Koho (unexamined utility model application publication) No. 142119/80 discloses bags for artificial anus which have an adsorbent paper/synthetic resin film structure, with an
5 excessive amount of an adsorbent contained in the adsorbent as incorporated therein on the occasion of paper making.

A Japanese patent application filed under PTC and laid open under Kohyo No. 501631/82 discloses bags
10 chiefly intended for medical use which have a structure such that a vapor barrier layer, such as a vinylidene chloride-vinyl chloride copolymer layer, lies between two layers made of a blend of a chlorinated polyolefin and an olefin polymer. In the relevant specification,
15 mention is made, either as the prior art bags or bags for comparison, of bags for medical use which respectively have the following structures: polyethylene film, plasticized polyvinyl chloride film, a plasticized polyvinylidene chloride film, polyethylene/ethylene-vinyl
20 acetate copolymer laminate, ethylene-vinyl acetate copolymer/polyvinylidene chloride/ethylene-vinyl acetate copolymer laminate, and polyethylene/ethylene-vinyl acetate copolymer/polyvinylidene chloride/ethylene-vinyl acetate copolymer/polyethylene laminate, among
25 others.

Japanese Kokai Tokkyo Koho (unexamined patent application publication) No. 1246/85 discloses non-sound-producing films for the manufacture of ostomy bags which comprise either a layer of a blend of an ethylene-vinyl acetate copolymer and an elastic polyolefin or two layers of said blend and a gas/odor barrier layer of a vinylidene chloride copolymer, an ethylene-vinyl alcohol copolymer, a vinylidene fluoride-vinyl fluoride copolymer, a polyamide or the like as interposed between said two layers.

Japanese Kokai Tokkyo Koho No. 122527/85 discloses bags for excreta from the human body which are made of a 3-hydroxybutyrate polymer film or a laminate derived therefrom. As films usable for lamination to said film, there are mentioned water-soluble polymer films, such as polyvinyl alcohol films and polyethylene oxide films.

Japanese Kokai Jitsuyo-Shinan Koho No. 175248/85 discloses films for bags to be attached to an artificial anus which are produced by three-layer coextrusion of a blend of a saponified ethylene-vinyl acetate copolymer and a partially saponified ethylene-vinyl acetate copolymer (as middle layer) and an ethylene-(meth)acrylic ester copolymer (as sandwiching layers).

Japanese Kokai Tokkyo Koho No. 31151/86 discloses bags for receiving feces from the artificial anus which comprise a deodorizing coagulant disposed on the bag bottom and in the tubular section, where a readily
5 water-soluble paper species is used.

Bags currently in practical use for collecting filthy waste matter excreted from the artificial anus have a three-layer construction of ethylene vinyl- acetate copolymer (inside layer)/polyvinylidene
10 chloride/ethylenevinyl acetate copolymer (outside layer) or a four-layer construction derived from said three-layer construction by further lamination of a nonwoven fabric or a net-like structure.

Japanese Kokai Tokkyo Koho No. 155408/84 (the
15 applicant being the same as in the present application), which is citable in connection with the present invention, discloses a method of producing modified poly- vinyl alcohol which comprises saponifying a copolymer of an oxyalkylene group-containing unsaturated monomer
20 and vinyl acetate. However, no mention is made therein of bags for collecting filthy matter excreted from the artificial anus.

Bags for collecting filthy matter discharged through the artificial anus are required to have, among
25

others, the following properties:

- (1) The filthy matter collected can be prevented from leaking from them (water resistance);
- (2) No odor can leak out while they are worn (odor barrier property);
- (3) They will not produce any sound so that others can never become aware of the fact of wearing thereof (non-sound-producing property or flexibility);
- (4) They can be thrown into the flush toilet bowl without causing stopping up of the flush line (disposability in flush toilet);
- (5) Their feel and touch are never unpleasant to wearers (acceptability in touch).

The bags disclosed in the above-cited references cannot meet all the requirements mentioned above. Even those bags currently in practical use which have an ethylene-vinyl acetate copolymer/polyvinylidene chloride/ethylene-vinyl acetate copolymer three-layer structure or a four-layer structure derived therefrom by further lamination of a nonwoven fabric or a net-like material may possibly cause stopping up of the flush line if they are thrown into the flush toilet bowl, although they are fairly satisfactory in respect of water resistance, odor barrier property, flexibility and feel and touch.

It is no doubt that artificial anus bearers are increasing in number year by year. The number of those artificial anus bearers that have returned to work is also increasing. Under these circumstances, it has earnestly waited for the advent of bags capable of meeting all the requirements mentioned above.

Accordingly, it is an object of the invention to provide bags which can meet such requirements as mentioned above.

Summary of the Invention

The invention provides a container for filthy matter which is essentially made of a single-layer or multilayer packaging material comprising an oxyalkylene group-containing vinyl alcohol copolymer film layer.

Brief Description of the Drawings

In the accompanying drawings,

Fig. 1 is a plan view of an example of the container for filthy matter as provided by the invention; and

Fig. 2 and Fig. 3 each is a partial sectional view of an example of the container according to the invention, where the container is essentially made of a three-layer packaging material.

In the figures, the reference numeral 1 indicates a single-layer or multilayer packaging material compris-

ing an oxyalkylene group-containing vinyl alcohol
copolymer film layer, and 1a, 1b and 1c denote the
oxyalkylene group-containing vinyl alcohol copolymer
film layer, another polymer film layer and a nonwoven
5 fabric, respectively. The numeral 2 indicates a sealed
portion, and 3 an opening portion.

Detailed Description of the Invention

The oxyalkylene group-containing vinyl alcohol
copolymer to be used in accordance with the invention
10 is preferably a saponification product derived from a
copolymer of an ethylenically unsaturated monomer
containing an oxyalkylene group of the formula



wherein R and R' each independently is H or an alkyl
15 group (in particular a methyl or ethyl group) and n is
a positive integer, and vinyl acetate.

Specific examples of the oxyalkylene group-contain-
ing, ethylenically unsaturated monomer are polyoxy-
ethylene (meth)acrylate, polyoxypropylene (meth)acrylate,
20 polyoxyethylene (meth)acrylamide, polyoxypropylene
(meth)acrylamide, polyoxyethylene (1-(meth)acrylamido-
1,1-dimethylpropyl) ester, polyoxyethylene (meth)allyl
ether, polyoxypropylene (meth)allyl ether, polyoxy-
ethylene vinyl ether and polyoxypropylene vinyl ether.
25 In each case, the number of moles of oxyalkylene units

added, namely n, is about 1 to about 300, preferably about 5 to about 50. Among the examples given above, polyoxyethylene allyl ether is most practicable.

The oxyalkylene group-containing vinyl alcohol
5 copolymer can be prepared by copolymerizing an oxyalkylene group-containing, ethylenically unsaturated monomer such as mentioned above and vinyl acetate and then saponifying the resulting copolymer in an alcohol, such as methanol, ethanol or butanol, in the presence
10 of an alkali catalyst.

The degree of saponification of the vinyl acetate component should be at least 10 mole percent. Since, however, a higher degree of saponification is more advantageous for the utilization of the properties of
15 the vinyl alcohol group, the degree of saponification should generally be not less than 50 mole percent, preferably not less than 70 mole percent, more preferably not less than 90 mole percent.

The oxyalkylene group-containing vinyl alcohol
20 copolymer obtained by saponification should preferably have an oxyalkylene group content of 1 to 80 percent by weight, more preferably 2 to 60 percent by weight, most preferably 5 to 50 percent by weight. When said content is too small, the flexibility will be damaged
25 upon heat treatment of the film and conversely, when

said content is excessive, the odor barrier property of the vinyl alcohol-based copolymer will be decreased.

In carrying out the polymerization mentioned above, one or more other monomers may be present in an amount of not more than about 30 mole percent, for example one or more monomers selected from among vinyl esters other than vinyl acetate, alkyl vinyl ethers, alkyl allyl ethers, ethylenically unsaturated carboxylic acids, esters, salts and acid anhydrides of such acids, α -olefins, vinyl chloride and so forth.

In some instances, the oxyalkylene group-containing vinyl alcohol copolymer may also be prepared by reacting polyvinyl alcohol with an alkylene oxide or by graft polymerization of vinyl acetate on a polyoxyalkylene glycol followed by saponification of the polymerization product.

A film of such oxyalkylene group-containing vinyl alcohol copolymer can be produced, for example, by casting an aqueous solution of said polymer, by melt extruding the polymer under aqueous conditions, or by melt extruding the polymer.

The thus-obtained film as such is apt to have insufficient water resistance. Therefore, when the film is to be used alone as the unilayer packaging material or as the inside layer of the multilayer

packaging material, the film should desirably be
heat-treated at a temperature of about 120° to 260°C,
preferably about 130° to 240°C, so that it can become
such that it is soluble in water only at temperatures
5 not lower than 55°C and has a 10% Young's modulus value
of not more than 2×10^3 kg/cm² as measured at 20°C
and 50% RH (relative humidity).

The lowest temperature at which the film is
soluble in water is defined as a temperature at which
10 the dissolution of a film specimen, 3 cm x 3 cm in size
and 25 ± 2 μm in thickness, reaches not less than 99
percent by weight when said specimen is put in 2,000 ml
of cold water in a beaker and the temperature is then
immediately raised at a rate of 2°C per minute.

15 The container for filthy matter according to the
invention may be constructed with the above-mentioned
oxyalkylene group-containing vinyl alcohol copolymer
film layer alone. From the utility viewpoint, however,
said container should desirably be constructed by using
20 a multilayer packaging material consisting of at least
two layers resulting from combination of said copolymer
film layer with another polymer film layer, an entangled
fiber layer or a thin metal layer.

Suitable as the polymer film layer to be combined
25 with the specific copolymer layer are film layers of

olefin-based polymers, such as polyethylene, ethylene-propylene copolymers, ethylene-vinyl acetate copolymers, ethylene-acrylic ester copolymers and ionomers because of their being flexible and having water resistance.

5 Furthermore, film layers of polymers having gas barrier property, such as polyvinylidene chloride and ethylene-vinyl alcohol copolymers, as well as film layers of such polymers as polyvinyl chloride, polyesters, polyamides and polyurethanes may also be used.

10 As the entangled fiber layer, there may be mentioned nonwoven fabrics, woven fabrics, knitted fabrics, paper sheets and net-like structures, among others.

The thin metal layer is, for example, a vapor deposited
15 metal layer or a metal foil layer.

When the container is made of a multilayer packaging material consisting of at least three layers, a particularly preferred constitution thereof comprises, as shown in Fig. 2 and Fig. 3, said oxyalkylene group-
20 containing vinyl alcohol copolymer layer as the container inside layer or the middle layer, a film layer of another polymer as the middle or inside layer, and a nonwoven fabric as the outside layer.

The multilayer packaging material can be produced,
25 for example by lamination of films, coating of a layer

with another layer, extrusion coating of a layer with another layer, coextrusion of layers and/or vapor deposition on a layer.

The container according to the invention generally
5 has a bag-like shape. As desired, however, it may also have a bottle-like, tray-like, box-like or tube-like shape, for instance.

The container for filthy matter which has the above-mentioned constitution in accordance with the
10 invention is particularly useful as a bag for collecting filthy matter extruded through the artificial anus. Furthermore, it can be used as a container for receiving various kinds of filthy matter as well as human or animal excrement.

15 The oxyalkylene group-containing vinyl alcohol copolymer film layer has the above-mentioned odor barrier property, flexibility and disposability in flush toilet at the same time.

Containers, for example bags, formed from a multi-
20 layer packaging material consisting of said layer and another polymer film layer, an entangled fiber layer and/or a thin metal layer can have disposability in flush toilet since, even when the other layer or layers are lacking in disposability in flush toilet, the
25 oxyalkylene group-containing vinyl alcohol copolymer

film layer with which said other layer or layers are laminated is swelled and deformed, so that the whole container can be deformed and thus becomes disposable in flush toilet.

5 Particularly when the inside or middle layer of the container is the oxyalkylene group-containing vinyl alcohol copolymer film layer, the middle or inside layer is another polymer film layer and the outside layer is a nonwoven fabric, the filthy matter collected and the odor thereof are prevented from leaking and the
10 container as a whole is flexible and will not produce sound and therefore never allows others to become aware of the fact of wearing thereof. Such container is disposable in flush toilet and has favorable feel and
15 touch because of the nonwoven fabric side coming into contact with the skin. Said container thus shows optimal performance characteristics as a bag for collecting filthy matter discharged from the artificial anus and therefore persons with an artificial anus can
20 wear it without worrying about wearing it.

The following examples are further illustrative of the present invention.

Example 1

Polyoxyethylene monoallyl ether with about 25
25 moles of oxyethylene added per mole thereof and vinyl

acetate were copolymerized in methanol in the presence of azobisisobutyronitrile and the copolymer obtained was then saponified in the conventional manner.

Thus was obtained a polyoxyethylene group-containing vinyl alcohol copolymer having a degree of saponification of the vinyl acetate component of 99 mole percent and a polyoxyethylene content of 30 percent by weight. A 4% aqueous solution of the polymer had a viscosity of 10 cps as measured at 20°C.

10 A 25% (by weight) aqueous solution of this polymer was prepared, cast onto a stainless steel endless belt and passed through a drier to give a 25- μ m-thick film.

This film was soluble in water at a temperature of 12°C and had a 10% Young's modulus value of 0.4×10^3 kg/cm².

This film was then heat-treated in a hot air drier at a temperature of 170°C for 1.5 minutes.

The heat-treated film thus obtained was soluble only at temperatures not lower than 59°C and had a 10% Young's modulus value of 1.2×10^3 kg/cm². Thus it had water resistance and flexibility.

Bags of the type shown in Fig. 1 were made of this heat-treated single-layer film and evaluated for their performance characteristics.

The heat-treated film obtained in Example 1 was laminated on one side thereof with a 25- μ m-thick low density polyethylene film by means of an adhesive. Bags of the type shown in Fig. 1 were made of the thus-obtained laminate with the polyethylene film layer as the outside layer.

Example 3

The heat-treated film obtained in Example 1 was provided on one side thereof with a 10- μ m-thick polyvinylidene chloride coating layer and further a nonwoven fabric having a weight of 20 g/m² was laminated with the composite (on the coating layer). Bags of the type shown in Fig. 1 were made of the thus-obtained three-layer composite with the nonwoven fabric layer serving as the outside layer.

Example 4

The heat-treated film obtained in Example 1 was laminated on one side thereof with a 30- μ m-thick ethylene-vinyl acetate copolymer (ethylene content 70 mole percent) film, followed by further lamination of a nonwoven fabric having a weight of 20 g/m². Bags of the type shown in Fig. 1 were made of the resultant composite with the nonwoven fabric side directed outward.

Example 5

The heat-treated film obtained in Example 1 was laminated on one side thereof with a 30- μ m-thick ethylene-vinyl acetate copolymer (ethylene content 70 mole percent) film, followed by further lamination of a nonwoven fabric weighing 20 g/m² on the other side of said heat-treated film. Bags of the type shown in Fig. 1 were made of the resultant composite.

Example 6

The heat-treated film obtained in Example 1 was laminated on one side thereof with an aluminum-deposited polyester film with the vapor deposition side faced with the heat-treated film, followed by further lamination of a nonwoven fabric having a weight of 20 g/m² thereon. Bags of the type shown in Fig. 1 were made of the resultant composite with the nonwoven fabric layer as the outside layer.

Example 7

Polyoxypropylene monomethacrylamide (about 15 moles of oxypropylene added) and vinyl acetate were copolymerized in methanol in the presence of azobisisobutyronitrile and the copolymer obtained was then saponified in the conventional manner.

Thus was obtained a polyoxypropylene group-containing vinyl alcohol copolymer having a degree of saponification of the vinyl acetate component of 99 mole percent and a

polyoxypropylene group content of 30 percent by weight.

A-25- μ m-thick film was produced from an aqueous solution of this polymer by the casting method and then heat-treated in a hot air drier maintained at a temperature of 170°C for 3 minutes.

The film after the heat treatment was soluble in water only at temperatures not lower than 62°C and had a 10% Young's modulus value of 1.8×10^3 kg/cm², hence it had water resistance and flexibility.

Bags of the type shown in Fig. 1 were made of this heat-treated film in the same manner as in Example 3 and evaluated for their performance characteristics.

Example 8

Polyoxyethylenepolyoxypropylene monoacrylate (about 10 moles of polyoxyethylene and about 10 moles of polyoxypropylene added) and vinyl acetate were copolymerized in methanol in the presence of azobisisobutyronitrile and the copolymer obtained was then saponified in the conventional manner.

Thus was obtained a polyoxyethylenepolyoxypropylene group-containing vinyl alcohol copolymer having a degree of saponification of the vinyl acetate component of 99 mole percent, a polyoxyethylene content of 15 percent by weight and a polyoxypropylene content of 15 percent by weight.

A 25- μ m-thick film was produced from an aqueous solution of this polymer by the casting method and then heat-treated in a hot air drier maintained at a temperature of 170°C for 3 minutes.

5 The film after the above heat treatment was soluble in water only at temperatures not lower than 60°C and had a 10% Young's modulus value of 1.3×10^3 kg/cm². Thus it had water resistance and flexibility.

Bags of the type shown in Fig. 1 were made of this heat-treated film in the same manner as in Example 1 and evaluated for their performance characteristics.

Comparative Example 1

A 25- μ m-thick film was produced from polyvinyl alcohol having a saponification degree of 99 mole percent and a 4% aqueous solution viscosity of 10 cps/20°C by the casting method.

This film was soluble in water at temperatures not lower than 65°C and had a 10% Young's modulus value of 3.9×10^3 kg/cm².

20 This film was heat-treated in a hot air drier maintained at a temperature of 170°C for 3 minutes.

The heat-treated film obtained was soluble in water at temperatures not lower than 91°C and had a 10% Young's modulus value of 5.1×10^3 kg/cm².

25 Bags of the type shown in Fig. 1 were made of this

heat-treated single-layer film and evaluated for their performance characteristics.

Comparative Example 2

5 The heat-treated film obtained in Comparative Example 1 was laminated on one side thereof with a 25- μ m-thick low-density polyethylene film by means of an adhesive. Bags of the type shown in Fig. 1 were made of this laminate with the polyethylene film layer as the outside layer.

10 Comparative Example 3

The heat-treated film obtained in Comparative Example 1 was provided on one side thereof with a 10- μ m-thick polyvinylidene chloride coating layer, followed by further lamination of a nonwoven fabric 15 having a weight of 20 g/cm² on the coating layer by means of an adhesive. Bags of the type shown in Fig. 1 were made of the resultant laminate with the nonwoven fabric layer as the outside layer.

Comparative Example 4

20 The film not yet heat-treated as obtained in Comparative Example 1 was laminated on one side thereof with a 30- μ m-thick ethylene-vinyl acetate (ethylene content 70 mole percent) film and, on the other side, with a nonwoven fabric having a weight of 20 g/cm². 25 Bags of the type shown in Fig. 1 were made of the

resultant laminate with the nonwoven fabric layer as the outside layer.

Comparative Example 5

Commercially available ostomy bags of a kind which
5 has an ethylene-vinyl acetate copolymer (inside layer)/poly-
vinylidene chloride/ethylene-vinyl acetate copolymer
(outside layer) three-layer structure were evaluated
for performance characteristics.

Comparative Example 6

10 The film not yet heat-treated as obtained in
Comparative Example 1 was provided on one side thereof
with a 15- μ m-thick film layer of a 3-hydroxybutyrate
copolymer containing 17 mole percent of hydroxybutyl
valerate by applying a methylene chloride solution
15 (containing o, p-toluenesulfonamide as a plasticizer in
an amount of 20% by weight based on said copolymer).
Bags of the type shown in Fig. 1 were made of the
resultant laminate with the coating layer as the inside
layer.

20 The evaluation results obtained with the bags of
Examples 1 to 8 and Comparative Examples 1 to 6 are
shown below in Table 1. The evaluation items and the
evaluation criteria are as follows:

Evaluation items and criteria

25 (1) Water resistance

O : Good

X : Poor

(2) Odor barrier property (a: ammonia; b:
trimethylamine; c: ethylmercaptan)

5 O : No odor is perceivable.

Δ : Odor is perceivable slightly but there is no
problem from the practical viewpoint.

X : Odor is too strong for the bags to be
practicable.

10 (3) Non-sound-producing property or flexibility

O : Very soft and flexible and good in
non-sound-producing property.

Δ : Non-sound-producing but somewhat
unsatisfactory in flexibility, or flexible
15 but somewhat unsatisfactory in non-sound-
producing property.

X : Poor in flexibility and in
non-sound-producing property.

(4) Disposability in flush toilet

20 O : No practical problem.

Δ : May cause some problem.

X : Undisposable.

(5) Feel and touch

⊙ : Very good

25 O : Good

Δ : Fair

X : Bad

Table 1

	1	2			3	4	5
		a	b	c			
Example 1	o	Δ	o	Δ	o	o	o
Example 2	o	Δ	o	o	o	o	Δ
Example 3	o	Δ	o	o	o	o	⊙
Example 4	o	Δ	o	o	o	o	⊙
Example 5	o	Δ	o	Δ	o	o	⊙
Example 6	o	Δ	o	o	o	o	o
Example 7	o	Δ	o	Δ	o	o	o
Example 8	o	Δ	o	o	o	o	o
Comparative Example 1	o	Δ	Δ	Δ	x	x	Δ
Comparative Example 2	o	Δ	o	Δ	x	x	x
Comparative Example 3	o	Δ	o	Δ	x	x	Δ
Comparative Example 4	x	x	o	x	Δ	Δ	Δ
Comparative Example 5	o	Δ	o	Δ	x	x	Δ
Comparative Example 6	o	Δ	o	x	Δ	Δ	x

What is claimed is:

1. A container for filthy matter which is essentially made of a single-layer or multilayer packaging material comprising an oxyalkylene group-
5 containing vinyl alcohol copolymer film layer.

2. A container for filthy mater as claimed in Claim 1, wherein the oxyalkylene group-containing vinyl alcohol copolymer film layer is soluble in water only at temperatures not lower than 55°C and has a 10%
10 Young's modulus value of not more than 2×10^3 kg/cm² as measured at 20°C and 50% RH (relative humidity).

3. A container for filthy matter as claimed in Claim 1, wherein the oxyalkylene group-containing vinyl alcohol copolymer has an oxyalkylene group content of 1
15 to 80 percent by weight.

4. A container for filthy matter as claimed in Claim 1, wherein the packaging material is a multilayer one comprising, in addition to the oxyalkylene group-containing vinyl alcohol copolymer film layer, a film
20 layer of another polymer, an entangled fiber layer or a thin metal layer.

5. A container for filthy matter as claimed in Claim 1, wherein the packaging material is a multilayer one consisting of at least 3 layers, the inside or
25 middle layer being the oxyalkylene group-containing

vinyl alcohol copolymer film layer, the middle or inside layer being a film layer of another polymer, and the outside layer being a nonwoven fabric.

6. A container for filthy matter as claimed in
5 Claim 1, which is in the form of a bag.

7. A container for filthy matter as claimed in Claim 1, which is a bag for collecting filthy waste matter discharged from the artificial anus.

10

15

20

25