

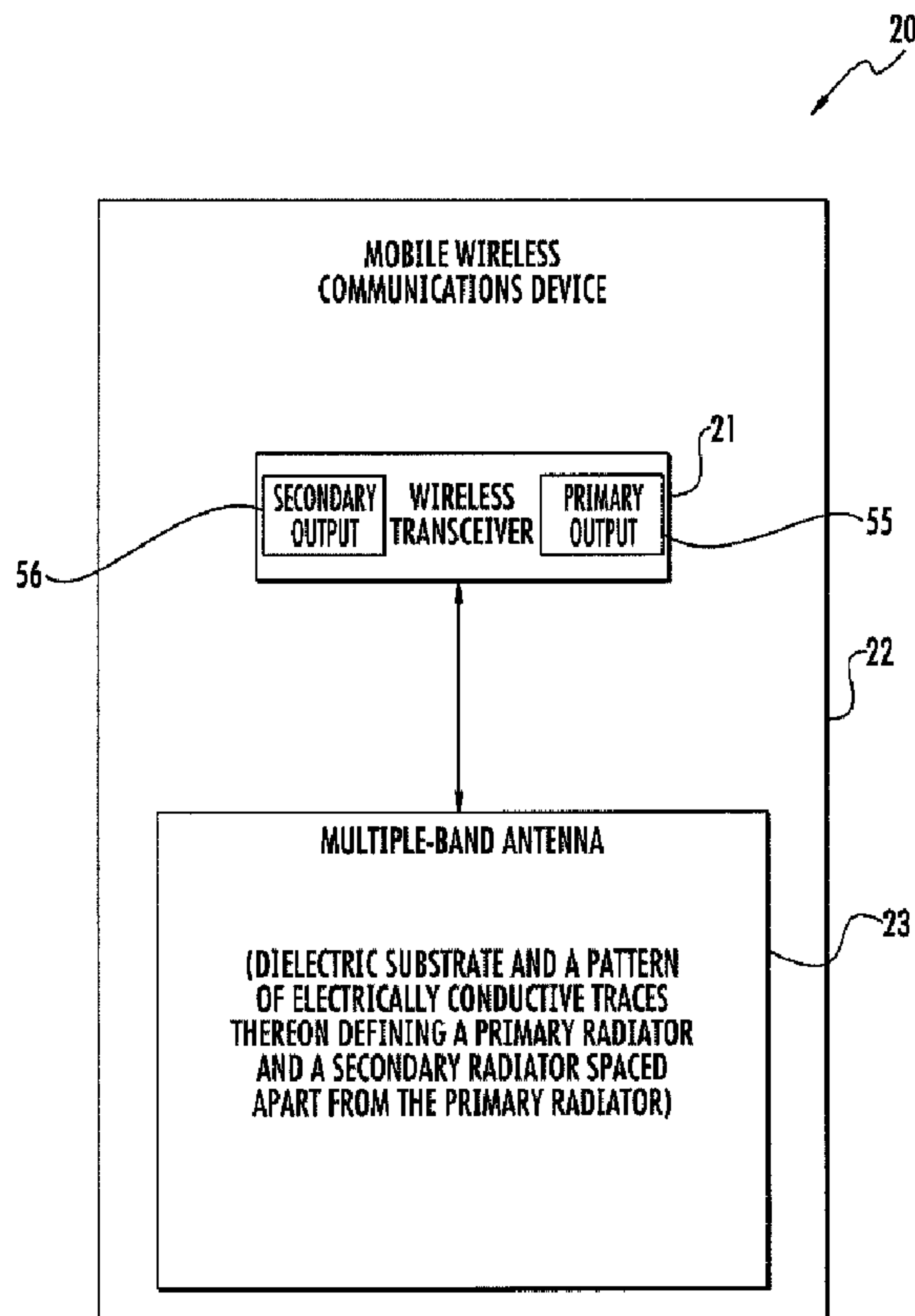

(22) Date de dépôt/Filing Date: 2013/10/04  
(41) Mise à la disp. pub./Open to Public Insp.: 2014/04/25  
(30) Priorité/Priority: 2012/10/25 (EP12190062.5)

(51) Cl.Int./Int.Cl. *H01Q 5/01* (2006.01),  
*H01Q 1/38* (2006.01), *H01Q 9/42* (2006.01),  
*H04W 88/02* (2009.01)  
(71) Demandeur/Applicant:  
BLACKBERRY LIMITED, CA  
(72) Inventeurs/Inventors:  
WONG, JOSHUA KWAN HO, CA;  
COOKE, ADRIAN MATTHEW, CA;  
LOY, ZHONG YI, CA;  
BAE, MUN SOO, CA  
(74) Agent: RIDOUT & MAYBEE LLP

(54) Titre : APPAREIL DE COMMUNICATION SANS FIL MOBILE AVEC ANTENNE A BANDES MULTIPLES ET  
PROCEDES CONNEXES  
(54) Title: MOBILE WIRELESS COMMUNICATIONS DEVICE WITH MULTIPLE-BAND ANTENNA AND RELATED  
METHODS



(57) **Abrégé/Abstract:**

A mobile wireless communications device (20) may include a housing (22), a wireless transceiver (21) carried by the housing and having a primary output (55), and a secondary output (56), and a multiple-band antenna (23) carried by the housing and coupled



(57) **Abrégé(suite)/Abstract(continued):**

to the wireless transceiver. The multiple-band antenna may include a dielectric substrate (24) and a pattern of electrically conductive traces thereon defining a primary radiator (26) and a secondary radiator (25) spaced apart from the primary radiator. The primary radiator may include a first elongate member (32) having a primary feed (27) coupled to the primary output, and a first reference member (33) spaced from the first elongate member and at least partially laterally surrounding the first elongate member and coupled to a reference voltage. The secondary radiator may include a second elongate member having a secondary feed (31) coupled to the secondary output.

**Abstract of the Disclosure**

A mobile wireless communications device (20) may include a housing (22), a wireless transceiver (21) carried by the housing and having a primary output (55), and a secondary output (56), and a multiple-band antenna (23) carried by the housing and coupled to the wireless transceiver. The multiple-band antenna may include a dielectric substrate (24) and a pattern of electrically conductive traces thereon defining a primary radiator (26) and a secondary radiator (25) spaced apart from the primary radiator. The primary radiator may include a first elongate member (32) having a primary feed (27) coupled to the primary output, and a first reference member (33) spaced from the first elongate member and at least partially laterally surrounding the first elongate member and coupled to a reference voltage. The secondary radiator may include a second elongate member having a secondary feed (31) coupled to the secondary output.

**MOBILE WIRELESS COMMUNICATIONS DEVICE WITH MULTIPLE-BAND ANTENNA  
AND RELATED METHODS**

**Technical Field**

**[0001]** The present invention relates to the field of communications, and, more particularly, to wireless communications and related methods.

**Background**

**[0002]** Cellular communication systems continue to grow in popularity and have become an integral part of both personal and business communications. Cellular telephones allow users to place and receive phone calls almost anywhere they travel. Moreover, as cellular telephone technology is improved, so too has the functionality of cellular devices. For example, many cellular devices now incorporate Personal Digital Assistant (PDA) features such as calendars, address books, task lists, calculators, memo and writing programs, etc. These multi-function devices usually allow users to wirelessly send and receive electronic mail (email) messages and access the Internet via a cellular network and/or a wireless local area network (WLAN), for example.

**[0003]** As the functionality of cellular devices continues to increase, so too does demand for smaller devices that are easier and more convenient for users to carry. Nevertheless, the move towards multi-functional devices makes miniaturization more difficult as the requisite number of installed components increases. Indeed, the typical cellular device may include several antennas, for example, a cellular antenna, a global positioning system antenna, and a WiFi IEEE 802.11g antenna. These antennas may comprise external antennas and internal antennas.

**[0004]** Generally speaking, internal antennas allow cellular devices to have a smaller footprint. Moreover, they are also preferred over external antennas for mechanical and ergonomic reasons. Internal antennas are also protected by the cellular device's housing and therefore tend to be more durable than external antennas. External antennas may be cumbersome and may make the cellular device difficult to use, particularly in limited-space environments. Yet, one potential drawback of typical internal antennas is that they are in relatively close proximity to the user's head when the cellular device is in use, thereby increasing the specific absorption rate (SAR). Yet more, hearing aid compatibility (HAC) may also be affected negatively. Also, other components within the cellular device may cause interference with or may be interfered by the internal antenna.

#### **Brief Description of the Drawings**

**[0005]** FIG. 1 is a schematic diagram of an example embodiment of the mobile wireless communications device.

**[0006]** FIG. 2 is a top plan view of an example embodiment of a multiple-band antenna from the mobile wireless communications device of FIG. 1.

**[0007]** FIG. 3 is a side elevation view of the multiple-band antenna of FIG. 2.

**[0008]** FIG. 4 is a top plan view of another example embodiment of a multiple-band antenna from the mobile wireless communications device of FIG. 1.

**[0009]** FIG. 5 is a side elevation view of the multiple-band antenna of FIG. 4.

**[0010]** FIG. 6 is a top plan view of yet another example embodiment of a multiple-band antenna from the mobile wireless communications device of FIG. 1 with the dielectric substrate

removed.

[0011] FIG. 7 is a side elevation view of the multiple-band antenna of FIG. 6.

[0012] FIG. 8 is a current distribution diagram of an example embodiment of a secondary radiator in an antenna that excites mode 3.

[0013] FIG. 9A is a current distribution diagram of an example embodiment of a primary radiator in the mobile wireless communications device in a first mode.

[0014] FIGS. 9B-9D are far field patterns of an example embodiment of a primary radiator in the mobile wireless communications device in a first mode.

[0015] FIG. 10A is a current distribution diagram of an example embodiment of a primary radiator in the mobile wireless communications device in a second mode.

[0016] FIGS. 10B-10D are far field patterns of an example embodiment of a primary radiator in the mobile wireless communications device in a second mode.

[0017] FIG. 11A is a current distribution diagram of an example embodiment of a primary radiator in the mobile wireless communications device in a third mode.

[0018] FIGS. 11B-11D are far field patterns of an example embodiment of a secondary radiator in the mobile wireless communications device in a third mode.

[0019] FIG. 12 is a schematic block diagram illustrating example components of a mobile wireless communications device that may be used with the mobile wireless communications device of FIG. 1.

#### **Detailed Description of the Preferred Embodiments**

[0020] The present description is made with reference to the accompanying drawings, in which embodiments are shown. However,

many different embodiments may be used, and thus the description should not be construed as limited to the embodiments set forth herein. Rather, these embodiments are provided so that this disclosure will be thorough and complete. Like numbers refer to like elements throughout, and prime notation is used to indicate similar elements in alternative embodiments.

**[0021]** Generally speaking, a mobile wireless communications device may include a housing, at least one wireless transceiver carried by the housing and having a primary output, and a secondary output, and a multiple-band antenna carried by the housing and coupled to the at least one wireless transceiver. The multiple-band antenna may include a dielectric substrate and a pattern of electrically conductive traces thereon defining a primary radiator and a secondary radiator spaced apart from the primary radiator. The primary radiator may include a first elongate member having a primary feed coupled to the primary output, and a first reference member spaced from the first elongate member and at least partially laterally surrounding the first elongate member and coupled to a reference voltage. The secondary radiator may include a second elongate member having a secondary feed coupled to the secondary output.

**[0022]** More specifically, the first reference member may comprise a first arm, and a second arm coupled thereto. The first arm may have an L-shape, and the second arm may comprise a proximal portion coupled to the first arm and having an L-shape, and a distal portion extending away from the proximal portion.

**[0023]** Additionally, the first arm may extend along a bottom of the housing. The second elongate member may have a first arm, and a second arm coupled thereto. The secondary feed may be on the second arm, and the first arm may extend at least partially along a bottom edge of the housing. The dielectric substrate may have a non-planar shape. The dielectric substrate

may be carried by a bottom of the housing, and the primary and secondary radiators may be carried by respective opposing first and second sides of the dielectric substrate. For example, the at least one wireless transceiver may comprise a Long Term Evolution (LTE) transceiver configured to operate the primary and secondary outputs in an LTE carrier aggregation mode.

**[0024]** Another aspect is directed to a method of making a multiple-band antenna for a mobile wireless communications. The method may comprise forming a multiple-band antenna to comprise a dielectric substrate and a pattern of electrically conductive traces thereon defining a primary radiator and a secondary radiator spaced apart from the primary radiator. The primary radiator may comprise a first elongate member having a primary feed coupled to the primary output, and a first reference member spaced from the first elongate member and at least partially laterally surrounding the first elongate member and coupled to a reference voltage. The secondary radiator may comprise a second elongate member having a secondary feed coupled to the secondary output.

**[0025]** Referring initially to FIGS. 1-3, a mobile wireless communications device **20** according to the present disclosure is now described. The mobile wireless communications device **20** illustratively includes a housing **22**, a wireless transceiver **21** carried by the housing and having a primary and secondary outputs **55**, **56**, and a multiple-band antenna **23** carried by the housing and coupled to the wireless transceiver. For example, the wireless transceiver **21** may comprise an LTE transceiver configured to operate the primary and secondary outputs **55**, **56** in an LTE carrier aggregation mode. In the illustrated embodiment, the multi-band antenna **23** may operate the primary output **55** at: LTE Band 7, 3, 8, 20, Primary; Wideband Code Division Multiple Access (WCDMA) Band 1, 2, 5, 8, Primary;



Global System for Mobile Communications (GSM) 850, 900, 1800, 1900; and operate the secondary output **56** at LTE Band 7, 3, 8, 20, Multiple Input Multiple Output (MIMO); WCDMA Band 1, 2, 5, 8 Diversity.

**[0026]** The multiple-band antenna **23** illustratively includes a dielectric substrate **24** and a pattern of electrically conductive traces thereon defining a primary radiator **26** and a secondary radiator **25** spaced apart from the primary radiator. The dielectric substrate **24** illustratively includes a non-planar shape, which illustratively fits the interior portions of the housing **22**. The dielectric substrate **24** may be carried by a bottom of the housing **22**, and the primary and secondary radiators **26**, **25** may be carried by respective opposing first and second sides of the dielectric substrate.

**[0027]** The primary radiator **26** illustratively includes a first elongate member **32** having a primary feed **27** coupled to the primary output **55**. The primary radiator **26** illustratively includes a first reference member **33** (e.g. ground reference member) spaced from the first elongate member **32** and at least partially laterally surrounding the first elongate member and coupled to a reference voltage (e.g. ground). The secondary radiator **25** illustratively includes a second elongate member having a secondary feed **31** coupled to the secondary output **56**. More specifically, the first reference member **33** illustratively includes a first arm **35**, and a second arm **51** coupled thereto.

**[0028]** In detail, the first elongate member **32** has a substantially rectangular-shape, and extends in parallel with the first arm **35** of the first reference member **33** (bending upward slightly). The first elongate member **32** illustratively includes a top portion defining a recess **57**, and a protruding portion **58** partially extending across the recess and including the primary feed **27**.

**[0029]** The first arm **35** of the first reference member **33** is substantially rectangle-shaped, and illustratively includes a proximal portion **59**, and a distal portion **60** coupled thereto and having an enlarged width. The distal portion **60** also defines a notch **61** having parallel sides, and a curved end. Additionally, the first arm **35** extends along a bottom of the housing **22**.

**[0030]** The second arm **51** comprises a proximal portion **41** coupled to the first arm **35** and having an L-shape, and a distal portion **42** extending away from the proximal portion and having a rectangular-shape. The distal portion **42** illustratively includes a reference connection **28** (e.g. ground connection), and defines a recess **62** having a curved end. The proximal and distal portions **41**, **42** have straight sides.

**[0031]** The first reference member **33** illustratively includes a third arm **47** extending almost entirely across the bottom edge of the dielectric substrate **24**. The third arm **47** illustratively includes a proximal portion **62**, and a distal portion **63** coupled thereto. The proximal portion **62** is rectangle-shaped, and the distal portion **63** is also rectangle-shaped. The distal portion **63** illustratively includes a greater width than that of the proximal portion **62** and has a rectangle-shaped notch **64** adjacent a corner thereof. The distal portion **63** also illustratively defines a square-shaped opening **65**.

**[0032]** The second elongate member illustratively includes a first arm **46**, and a second arm **34** coupled thereto. The secondary feed **31** illustratively is on the second arm **34**, and the first arm **46** may extend at least partially along a bottom edge of the housing **22**. In particular, the first arm **46** illustratively includes rectangle-shaped proximal and distal portions **66**, **67**, the distal portion defining a rectangle-shaped recess **68** on a side thereof. The second arm **34** illustratively includes a proximal portion **110**, a medial portion **111** coupled to

the proximal portion, and a distal portion **112** coupled to the medial portion. The proximal portion **110** is rectangle-shaped, and the medial portion **111** is U-shaped. The distal portion **112** comprises an L-shaped portion coupled to the medial portion **111**, and a rectangle-shaped portion coupled to the L-shaped portion.

**[0033]** Another aspect is directed to a method of making a multiple-band antenna **23** for a mobile wireless communications **20**. The method may comprise forming a multiple-band antenna **23** to comprise a dielectric substrate **24** and a pattern of electrically conductive traces thereon defining a primary radiator **26** and a secondary radiator **25** spaced apart from the primary radiator. The primary radiator **26** may comprise a first elongate member having a primary feed **27** coupled to the primary output, and a first reference member **33** spaced from the first elongate member and at least partially laterally surrounding the first elongate member and coupled to a reference voltage. The secondary radiator **25** may comprise a second elongate member having a secondary feed **31** coupled to the secondary output.

**[0034]** Referring now additionally to FIGS. 4-5, another embodiment of the multiple-band antenna **23'** is now described. In this embodiment of the multiple-band antenna **23'**, those elements already discussed above with respect to FIGS. 1-3 are given prime notation and most require no further discussion herein. This embodiment differs from the previous embodiment in that the first arm **35'** illustratively has an L-shape, and uniform width throughout. The first arm **35'** also does not include the recess from the embodiments of FIGS. 2-3. The third arm **47'** also does not include the notch of the prior embodiment, but does include an L-shaped turn **120'** in a medial portion thereof. The second arm **34'** of the secondary radiator **25'** illustratively includes a single L-shaped turn **121'**, rather the multiple turns of the prior embodiments. In the illustrated

embodiment, the multi-band antenna **23'** may operate the primary output **55'** at: LTE Band 4, 13 Primary; CDMA 1x Voice, EVDO Diversity; WCDMA Band 1, 2, 5, 8 Primary; GSM 850, 900, 1800, 1900; and operate the secondary output **56'** at: LTE Band 13 MIMO; CDMA 1x Voice Primary; and CDMA 1x EVDO Diversity.

**[0035]** Referring now additionally to FIGS. 6-7, another embodiment of the multiple-band antenna **23''** is now described. In this embodiment of the multiple-band antenna **23''**, those elements already discussed above with respect to FIGS. 1-3 are given double prime notation and most require no further discussion herein. This embodiment differs from the previous embodiment in that the third arm **47''** includes the rectangle-shaped recess **64''** in a medial portion rather than the corner of the embodiment of FIGS. 2-3. Also, the secondary radiator **25''** has a general C-shape including the first and second arms **46''**, **34''**. The first arm **46''** illustratively includes a pair of rectangle-shaped branches **115'**, **116'**. The second arm **34''** illustratively has an L-shape and is rectangle-shaped throughout. In the illustrated embodiment, the multi-band antenna **23''** may operate the primary output **55''** at: LTE Band 2, 4, 5, 17 Primary; WCDMA Band 1, 2, 5, 8 Primary; GSM 850, 900, 1800, 1900; and operate the secondary output **56''** at: LTE Band 2, 4, 5, 17 MIMO; WCDMA Band 1, 2, 5, 8 Diversity.

**[0036]** With regards to the operating bands of the embodiments of FIGS. 2-7, the operating frequencies are shown in Table 1 herein.

Band	Frequency Range (MHz)
LTE 17	704–746
LTE 13	746–777
LTE 20	791–862
LTE/WCDMA 5 GSM 850 CDMA 1x Cell	824–894
LTE/WCDMA 8 GSM 900	880–960
LTE 3 LTE/WCDMA 4 Tx GSM 1800	1710–1880
LTE/WCDMA 2 GSM 1900 CDMA 1x PCS	1850–1990
WCDMA 1	1920–2170
LTE 7	2500–2690

Table 1: Operating Frequencies

**[0037]** Theory of Operation

The basis of this multiple-band antenna **23** relies on exciting different characteristics modes in the chassis of the mobile wireless communications device **20**. Characteristics modes describe the current distribution and far field radiation that are unique to a given conducting body at a specific frequency. In theory, a metallic object could possess infinite number of characteristic mode for a given frequency, however not all modes are excitable in practice. Mathematically, characteristics modes on a metal object are precisely described by the following close boundary problem:

$$[L(J) - E] = 0,$$

where the operator L is defined as

$$L(J) = j\omega A(J) - \nabla\Phi(J); \text{ and}$$

A and  $\Phi$  are the vector and scalar potentials due to a given current distribution respectively.

**[0038]** Since  $A$  and  $\Phi$  are integrals defined over the closed surface, the problem can be rewritten in terms of impedances and arrive at the eigenvalues problem as

$$Z(J) = L(J); \text{ and}$$

$$Z(J) = vM(J);$$

where matrix  $M$  is a symmetric matrix that diagonalizes the matrix  $Z$ ,  $v$  are the eigenvalues, and  $J$  are the eigenvectors. A characteristic mode refers to a given set of eigenvalue and eigenvector.

**[0039]** By definition, the eigenvectors associated with a particular conducting body are orthogonal to each other and must satisfy the orthogonality relationships  $\langle J_m | Z J_n \rangle = 0$ , for  $m \neq n$ . In other words, the current distribution and radiation pattern of one mode is un-correlated to the current distribution and radiation pattern of another mode, even though there is only one radiating element. By exploiting this orthogonality principle of characteristic modes, the multiple-band antenna **23** can achieve low correlation at low frequencies despite having only one radiator and it is this particular property that enables this feature. More specifically, the first elongate member **32** in N-series excites a dominant mode 1 ( $v_1, J_1$ ) and the secondary radiator **25** excites a dominant mode 3 ( $v_3, J_3$ ).

**[0040]** Referring now to FIGS. 8-11D, diagram **77** shows the current distribution, and diagrams **79, 81, 83** show the far field patterns for the mobile wireless communications device **20** while in mode 1 at 704 MHz. Diagram **85** shows the current distribution, and diagrams **87, 89, 91** show the far field patterns for the mobile wireless communications device **20** while in mode 2 at 704 MHz. Diagrams **93, 70** show the current

distribution, and diagrams **95**, **97**, **99** show the far field patterns for the mobile wireless communications device **20** while in mode 3 at 704 MHz.

**[0041]** The multiple-band antenna **23** may exploit the natural resonances, known as characteristics modes, of an arbitrary metallic object to achieve low correlation between multiple antennas in a MIMO system. Typical MIMO systems may rely on an antenna array where the antenna elements are usually separated from each other by half of a wavelength. For low frequency LTE bands, such as Band 17 (704 MHz - 746 MHz) or Band 13 (746 MHz - 777 MHz), the half wavelength spatial separation may not be achievable in handheld devices, such as a smartphone where the overall dimension of the device is on the order of a quarter wavelength of the operating wavelength. Low frequency is particularly interesting because radiation at low frequencies is predominantly due to the mobile device's chassis and the antenna element serves as an excitation element. Consequently, the current distributions excited by each antenna element in a MIMO system share one radiator, i.e. the chassis of the device. This is in conflict to the multi-antenna requirement of MIMO because multiple antennas usually mean that there are multiple radiating elements, which may not be true in a handset. The multiple-band antenna **23** may relax this requirement and enable: high performance MIMO with a single radiating element; and systematic antenna element placement with minimal correlation and gain imbalance.

**[0042]** With regards to Table 2 below, the measured performance of the multi-band antenna **23** in varying operating frequencies is shown. Of particular interest is the LTE MIMO and Correlation section, which demonstrate the low correlation values achieved with the multi-band antenna **23**.

Verizon  
LTE Rx are 10MHz BW

Voice	Conducted		Required				Conducted					
	Power	TRP	Gain	Measured Gain			Sensitivity	TIS	Required Gain	Measured Gain		
Cell (FS)	24	18	-6	-4.6	-5.0	-5.4	-108	-101	-7	-5.4	-5.3	-5.2
			Margin	1.4	1.0	0.6			Margin	1.6	1.8	1.8
PCS (FS)	24	19	-5	-5.1	-4.8	-4.9	-107	-101	-6	-5.2	-5.7	-6.0
			Margin	0.1	0.3	0.1			Margin	0.8	0.3	0.0

EVDO	Conducted		Required				Conducted					
	Power	TRP	Gain	Measured Gain			Sensitivity	TIS	Required Gain	Measured Gain		
Cell (FS)	24	18	-6	-4.6	-5.0	-5.4	-109.5	-102.5	-7	-5.4	-5.3	-5.2
			Margin	1.4	1.0	0.6			Margin	1.6	1.8	1.8
PCS (FS)	24	19	-5	-5.1	-4.8	-4.9	-108.5	-102.5	-6	-5.2	-5.7	-6.0
			Margin	0.1	0.3	0.1			Margin	0.8	0.3	0.0

LTE	Conducted		Required				Conducted					
	Power	TRP	Gain	Measured Gain			Sensitivity	TIS	Required Gain	Measured Gain		
Band 13	23.5	18	-5.5	-5.2	-5.0	-5.5	-98.5	-91	-7.5	-6.6	-6.3	-5.8
			Margin	0.3	0.5	0.0			Margin	0.9	1.2	1.8
Band 4	23.5	19	-4.5	-4.3	-3.8	-3.8	-97	-91	-6	-4.3	-4.3	-4.7
			Margin	0.2	0.7	0.7			Margin	1.8	1.7	1.3

LTE MIMO	Conducted		Required				Conducted				Delta with Primary				
	Power	TRP	Gain	Measured Gain			Sensitivity	TIS	Required Gain	Measured Gain					
Band 13	23.5	18	-5.5	-5.2	-5.0	-5.5	-98.7	-88	-10.7	-9.8	-9.7	-9.3	3.2	3.4	3.6
			Margin	0.3	0.5	0.0			Margin	0.9	1.0	1.4			
Band 4	23.5	19	-4.5	-4.3	-3.8	-3.8	-97	-88	-9.0	-9.8	-7.9	-7.3	4.9	3.6	2.6
			Margin	0.2	0.7	0.7			Margin	0.0	1.1	1.7			

Correlation	Conducted		Required				Measured					
	Power	TRP	Gain	Measured Gain			Sensitivity	TIS	Required Gain	Measured Gain		
Band 13	23.5	18	-5.5	-5.2	-5.0	-5.5	-98.7	-88	-10.7	-9.8	-9.7	-9.3
			Margin	0.3	0.5	0.0			Margin	0.17	0.18	0.18
Band 4	23.5	19	-4.5	-4.3	-3.8	-3.8	-97	-88	-9.0	-9.8	-7.9	-7.3
			Margin	0.2	0.7	0.7			Margin	0.44	0.43	0.44

Diversity	Conducted		Required				Conducted				Delta with Primary				
	Power	TRP	Gain	Measured Gain			Sensitivity	TIS	Required Gain	Measured Gain					
Cell (FS)	24	18	-6	-4.6	-5.0	-5.4	-108	-95	-13	-9.2	-9.3	-9.3	3.8	4.1	4.0
			Margin	1.4	1.0	0.6			Margin	3.8	3.7	3.7			
PCS (FS)	24	19	-5	-5.1	-4.8	-4.9	-107	-95	-12	-5.7	-3.9	-3.6	1.5	1.9	2.4
			Margin	0.1	0.3	0.1			Margin	8.3	8.1	8.4			

Table 2: Measured Performance

[0043] Example components of a mobile wireless communications device 1000 that may be used in accordance with the above-described embodiments are further described below with reference to FIG. 12. The device 1000 illustratively includes a housing 1200, a keyboard or keypad 1400 and an output device 1600. The output device shown is a display 1600, which may comprise a full graphic liquid crystal display (LCD). Other types of output devices may alternatively be utilized. A processing device 1800 is contained within the housing 1200 and is coupled between the



keypad **1400** and the display **1600**. The processing device **1800** controls the operation of the display **1600**, as well as the overall operation of the mobile device **1000**, in response to actuation of keys on the keypad **1400**.

**[0044]** The housing **1200** may be elongated vertically, or may take on other sizes and shapes (including clamshell housing structures). The keypad may include a mode selection key, or other hardware or software for switching between text entry and telephony entry.

**[0045]** In addition to the processing device **1800**, other parts of the mobile device **1000** are shown schematically in FIG. 12. These include a communications subsystem **1001**; a short-range communications subsystem **1020**; the keypad **1400** and the display **1600**, along with other input/output devices **1060**, **1080**, **1100** and **1120**; as well as memory devices **1160**, **1180** and various other device subsystems **1201**. The mobile device **1000** may comprise a two-way RF communications device having data and, optionally, voice communications capabilities. In addition, the mobile device **1000** may have the capability to communicate with other computer systems via the Internet.

**[0046]** Operating system software executed by the processing device **1800** is stored in a persistent store, such as the flash memory **1160**, but may be stored in other types of memory devices, such as a read only memory (ROM) or similar storage element. In addition, system software, specific device applications, or parts thereof, may be temporarily loaded into a volatile store, such as the random access memory (RAM) **1180**. Communications signals received by the mobile device may also be stored in the RAM **1180**.

**[0047]** The processing device **1800**, in addition to its operating system functions, enables execution of software applications **1300A-1300N** on the device **1000**. A predetermined

set of applications that control basic device operations, such as data and voice communications **1300A** and **1300B**, may be installed on the device **1000** during manufacture. In addition, a personal information manager (PIM) application may be installed during manufacture. The PIM may be capable of organizing and managing data items, such as e-mail, calendar events, voice mails, appointments, and task items. The PIM application may also be capable of sending and receiving data items via a wireless network **1401**. The PIM data items may be seamlessly integrated, synchronized and updated via the wireless network **1401** with corresponding data items stored or associated with a host computer system.

**[0048]** Communication functions, including data and voice communications, are performed through the communications subsystem **1001**, and possibly through the short-range communications subsystem **1020**. The communications subsystem **1001** includes a receiver **1500**, a transmitter **1520**, and one or more antennas **1540** and **1560**. In addition, the communications subsystem **1001** also includes a processing module, such as a digital signal processor (DSP) **1580**, and local oscillators (LOs) **1601**. The specific design and implementation of the communications subsystem **1001** is dependent upon the communications network in which the mobile device **1000** is intended to operate. For example, a mobile device **1000** may include a communications subsystem **1001** designed to operate with the Mobitex™, Data TAC™ or General Packet Radio Service (GPRS) mobile data communications networks, and also designed to operate with any of a variety of voice communications networks, such as Advanced Mobile Phone System (AMPS), time division multiple access (TDMA), code division multiple access (CDMA), Wideband code division multiple access (W-CDMA), personal communications service (PCS), GSM (Global System for Mobile

Communications), enhanced data rates for GSM evolution (EDGE), etc. Other types of data and voice networks, both separate and integrated, may also be utilized with the mobile device **1000**. The mobile device **1000** may also be compliant with other communications standards such as 3GSM, 3rd Generation Partnership Project (3GPP), Universal Mobile Telecommunications System (UMTS), 4G, etc.

**[0049]** Network access requirements vary depending upon the type of communication system. For example, in the Mobitex and DataTAC networks, mobile devices are registered on the network using a unique personal identification number or PIN associated with each device. In GPRS networks, however, network access is associated with a subscriber or user of a device. A GPRS device therefore typically involves use of a subscriber identity module, commonly referred to as a SIM card, in order to operate on a GPRS network.

**[0050]** When required network registration or activation procedures have been completed, the mobile device **1000** may send and receive communications signals over the communication network **1401**. Signals received from the communications network **1401** by the antenna **1540** are routed to the receiver **1500**, which provides for signal amplification, frequency down conversion, filtering, channel selection, etc., and may also provide analog to digital conversion. Analog-to-digital conversion of the received signal allows the DSP **1580** to perform more complex communications functions, such as demodulation and decoding. In a similar manner, signals to be transmitted to the network **1401** are processed (e.g. modulated and encoded) by the DSP **1580** and are then provided to the transmitter **1520** for digital to analog conversion, frequency up conversion, filtering, amplification and transmission to the communication network **1401** (or networks) via the antenna **1560**.

**[0051]** In addition to processing communications signals, the DSP **1580** provides for control of the receiver **1500** and the transmitter **1520**. For example, gains applied to communications signals in the receiver **1500** and transmitter **1520** may be adaptively controlled through automatic gain control algorithms implemented in the DSP **1580**.

**[0052]** In a data communications mode, a received signal, such as a text message or web page download, is processed by the communications subsystem **1001** and is input to the processing device **1800**. The received signal is then further processed by the processing device **1800** for an output to the display **1600**, or alternatively to some other auxiliary I/O device **1060**. A device may also be used to compose data items, such as e-mail messages, using the keypad **1400** and/or some other auxiliary I/O device **1060**, such as a touchpad, a rocker switch, a thumb-wheel, or some other type of input device. The composed data items may then be transmitted over the communications network **1401** via the communications subsystem **1001**.

**[0053]** In a voice communications mode, overall operation of the device is substantially similar to the data communications mode, except that received signals are output to a speaker **1100**, and signals for transmission are generated by a microphone **1120**. Alternative voice or audio I/O subsystems, such as a voice message recording subsystem, may also be implemented on the device **1000**. In addition, the display **1600** may also be utilized in voice communications mode, for example to display the identity of a calling party, the duration of a voice call, or other voice call related information.

**[0054]** The short-range communications subsystem enables communication between the mobile device **1000** and other proximate systems or devices, which need not necessarily be similar devices. For example, the short-range communications subsystem

may include an infrared device and associated circuits and components, a Bluetooth™ communications module to provide for communication with similarly-enabled systems and devices, or a NFC sensor for communicating with a NFC device or NFC tag via NFC communications.

**[0055]** Many modifications and other embodiments will come to the mind of one skilled in the art having the benefit of the teachings presented in the foregoing descriptions and the associated drawings. Therefore, it is understood that various modifications and embodiments are intended to be included within the scope of the appended claims.

**THAT WHICH IS CLAIMED IS:**

1. A mobile wireless communications device (20) comprising:
  - a housing (22);
  - at least one wireless transceiver (21) carried by said housing and having a primary output (55), and a secondary output (56); and
  - a multiple-band antenna (23) carried by said housing and coupled to said at least one wireless transceiver, said multiple-band antenna comprising
    - a dielectric substrate (24) and a pattern of electrically conductive traces thereon defining a primary radiator (26) and a secondary radiator (25) spaced apart from said primary radiator,
    - said primary radiator comprising a first elongate member (32) having a primary feed (27) coupled to said primary output, and a first reference member (33) spaced from said first elongate member and at least partially laterally surrounding said first elongate member and coupled to a reference voltage,
    - said secondary radiator comprising a second elongate member having a secondary feed (31) coupled to said secondary output.
2. The mobile wireless communications device of claim 1 wherein said first reference member comprises a first arm (35), and a second arm (51) coupled thereto.
3. The mobile wireless communications device of claim 2 wherein said first arm has an L-shape; and wherein said second arm comprises a proximal portion (41) coupled to said first arm and having an L-shape, and a distal portion (42)

extending away from said proximal portion.

4. The mobile wireless communications device of claim 2 wherein said first arm extends along a bottom of said housing.

5. The mobile wireless communications device of claim 1 wherein said second elongate member has a first arm (46), and a second arm (34) coupled thereto.

6. The mobile wireless communications device of claim 5 wherein said secondary feed is on said second arm; and wherein said first arm extends at least partially along a bottom edge of said housing.

7. The mobile wireless communications device of claim 1 wherein said dielectric substrate has a non-planar shape.

8. The mobile wireless communications device of claim 1 wherein said dielectric substrate is carried by a bottom of said housing; and wherein said primary and secondary radiators are carried by respective opposing first and second sides of said dielectric substrate.

9. The mobile wireless communications device of claim 1 wherein said at least one wireless transceiver comprises a Long Term Evolution (LTE) transceiver configured to operate said primary and secondary outputs in an LTE carrier aggregation mode.

10. A multiple-band antenna (23) for a mobile wireless communications device (20) comprising a housing (22), and at least one wireless transceiver (21) carried by the housing, said multiple-band antenna comprising:

a dielectric substrate and a pattern of electrically conductive traces thereon defining a primary radiator (26) and a secondary radiator (25) spaced apart from said primary radiator;

said primary radiator comprising a first elongate member (32) having a primary feed (27) coupled to a primary output (55), and a first reference member (33) spaced from said first elongate member and at least partially laterally surrounding said first elongate member and coupled to a reference voltage;

said secondary radiator comprising a second elongate member having a secondary feed (31) coupled to a secondary output (56).

11. The multiple-band antenna of claim 10 wherein said first reference member comprises a first arm (35), and a second arm (51) coupled thereto.

12. The multiple-band antenna of claim 11 wherein said first arm has an L-shape; and wherein said second arm comprises a proximal portion (41) coupled to said first arm and having an L-shape, and a distal portion (42) extending away from said proximal portion.

13. A method of making a multiple-band antenna (23) for a mobile wireless communications device (20) comprising:

forming a multiple-band antenna to comprise a



dielectric substrate and a pattern of electrically conductive traces thereon defining a primary radiator (26) and a secondary radiator (25) spaced apart from the primary radiator;

the primary radiator comprising a first elongate member (32) having a primary feed (27) coupled to a primary output (55), and a first reference member (33) spaced from the first elongate member and at least partially laterally surrounding the first elongate member and coupled to a reference voltage;

the secondary radiator comprising a second elongate member having a secondary feed (31) coupled to a secondary output (56).

14. The method of claim 13 wherein the first reference member comprises a first arm (35), and a second arm (51) coupled thereto.

15. The method of claim 14 wherein the first arm has an L-shape; and wherein the second arm comprises a proximal portion (41) coupled to the first arm and having an L-shape, and a distal portion (42) extending away from the proximal portion.

Application number / Numéro de demande: 2829433

Figures: 9 ABCD, 10 ABCD, 11 ABCD

Pages: 6/9, 7/9, 8/9

15 Oct 2013

Drawings

Unscannable items received with this application  
(Request original documents in File Prep. Section on the 10<sup>th</sup> floor)

*Jun*

Documents reçu avec cette demande ne pouvant être balayés  
(Commander les documents originaux dans la section de la préparation  
des dossiers au 10<sup>ième</sup> étage)

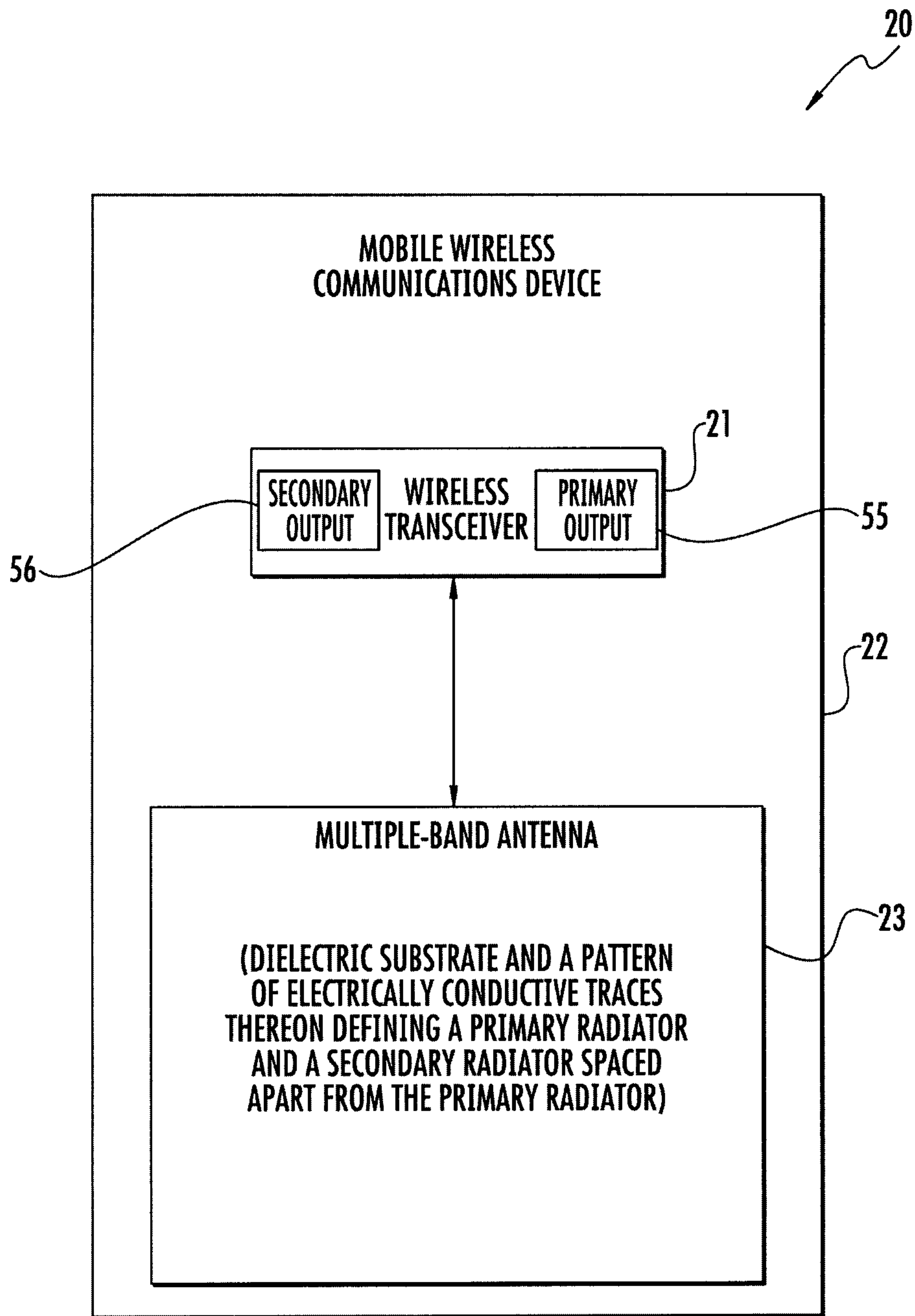
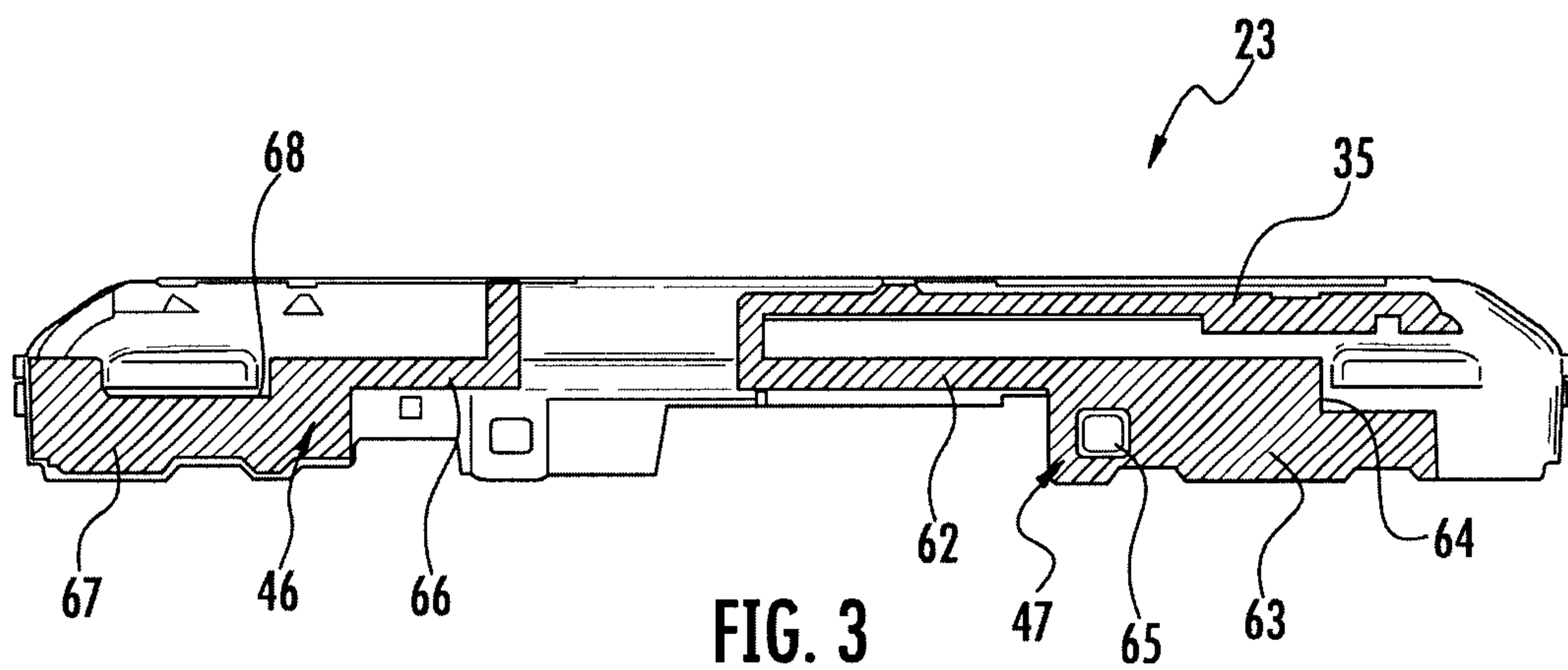
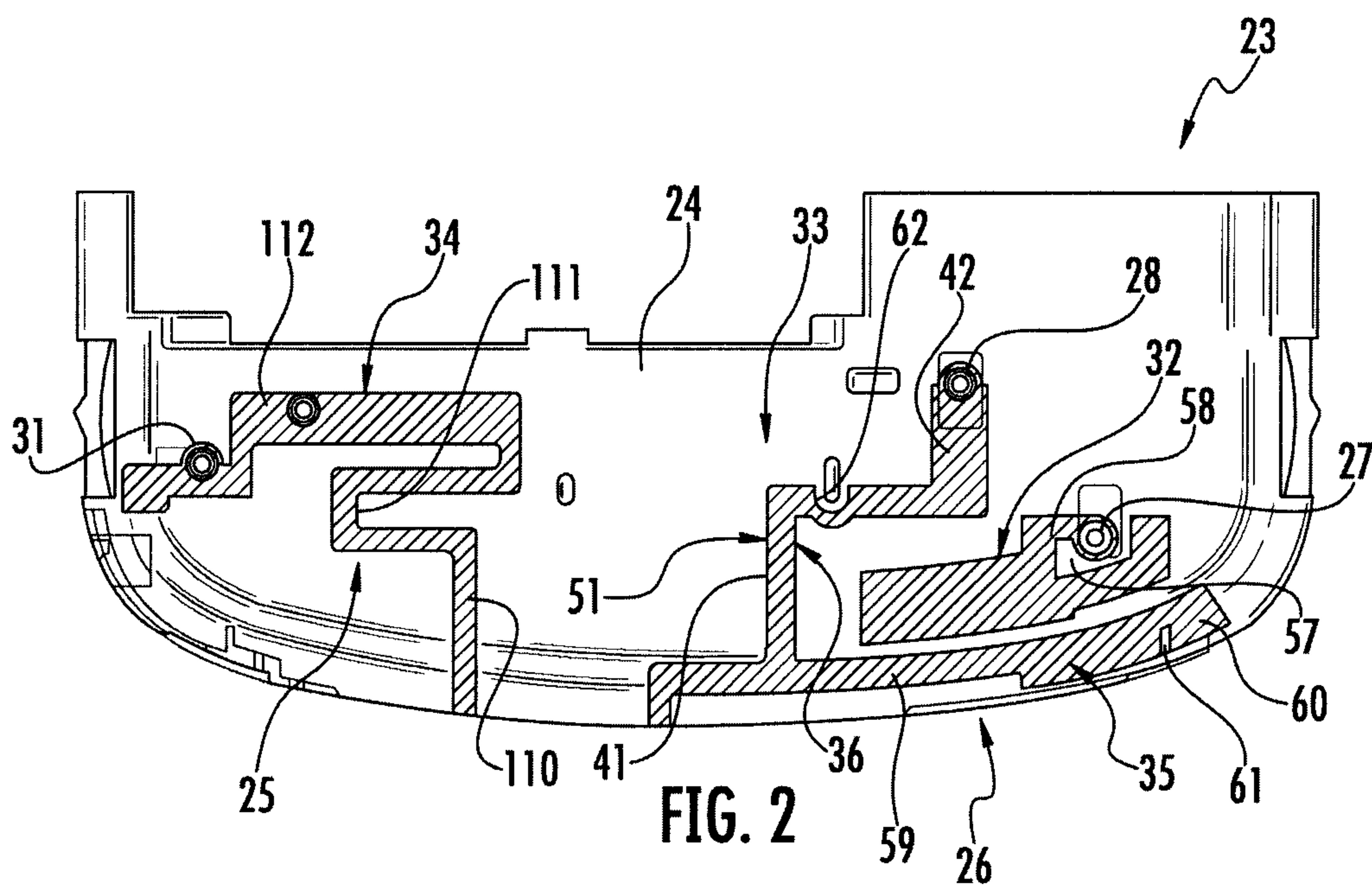
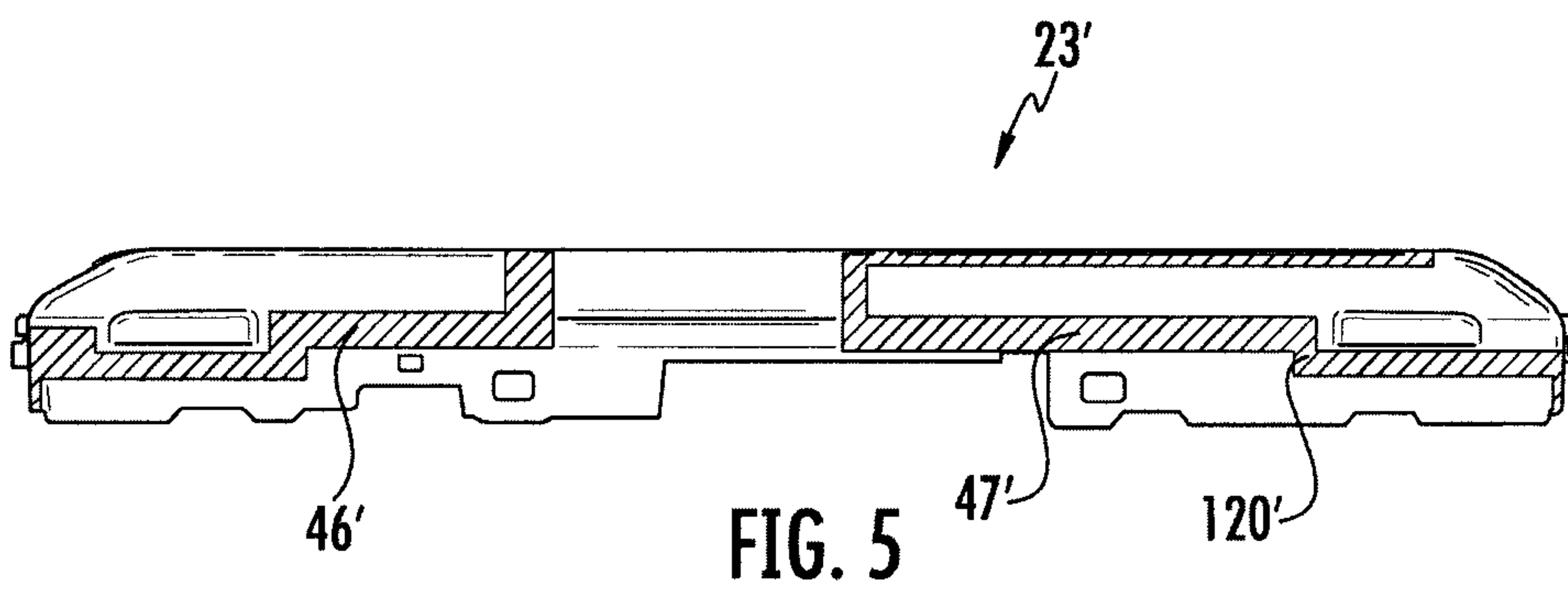
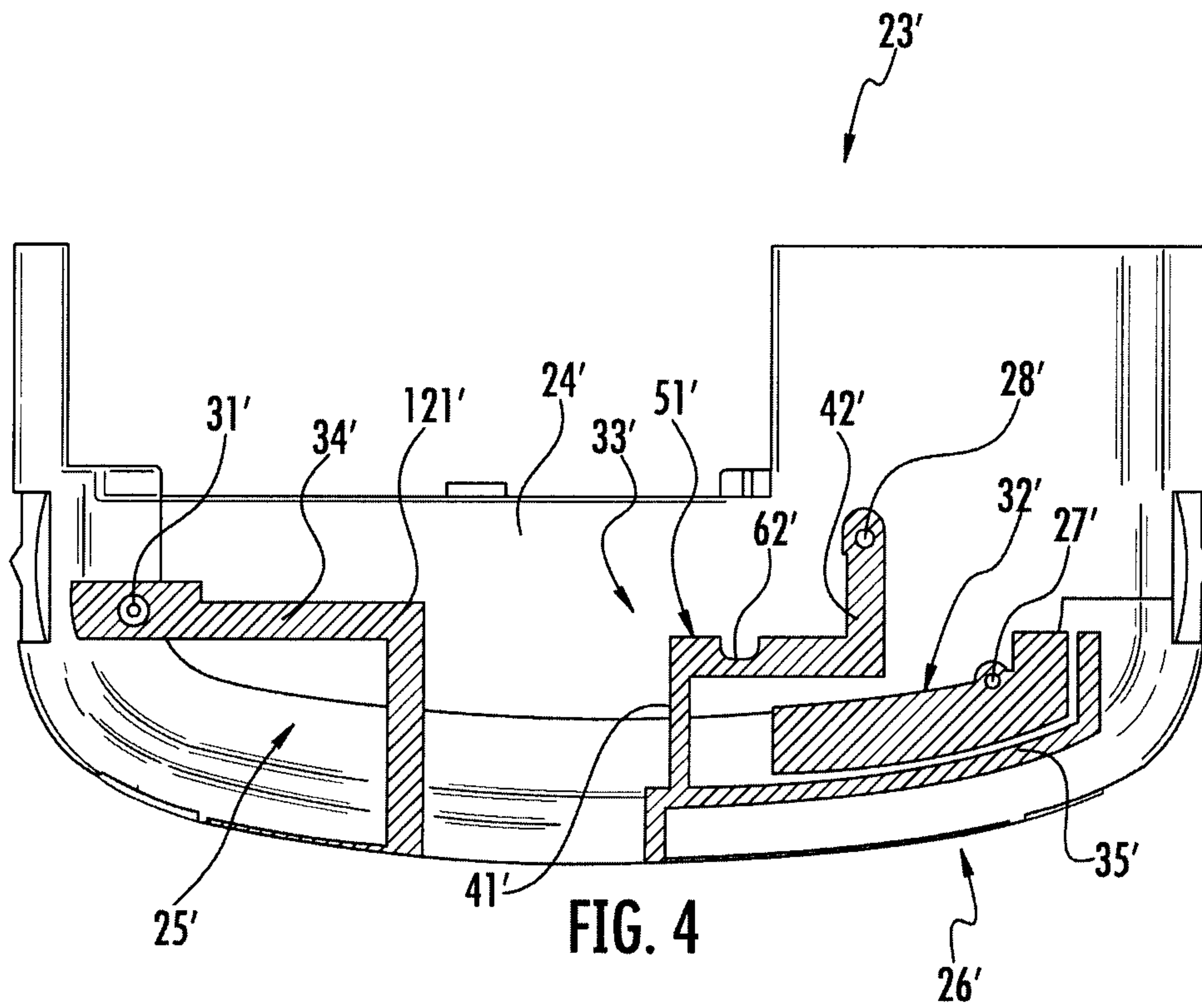

FIG. 1



3/9



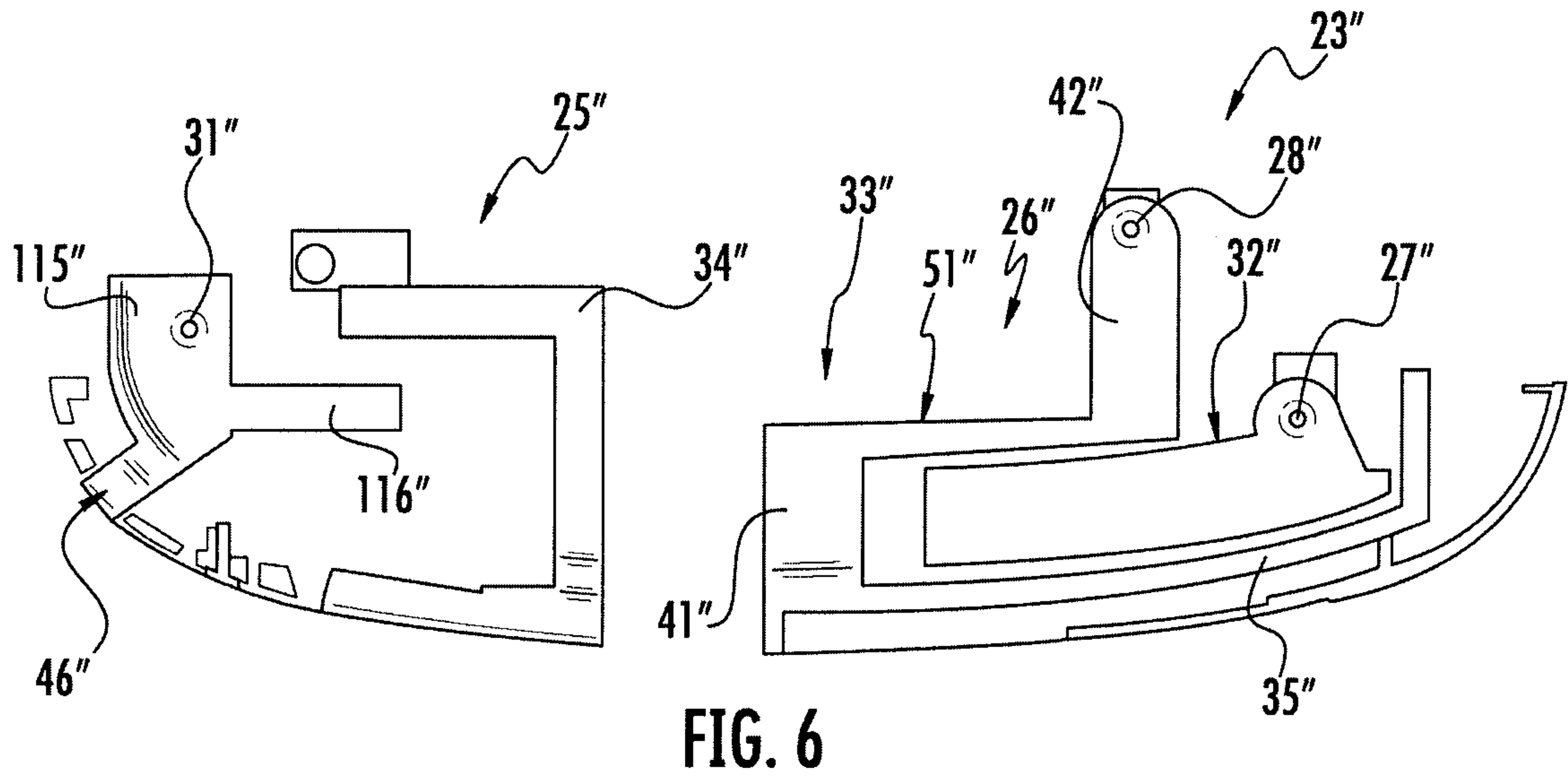
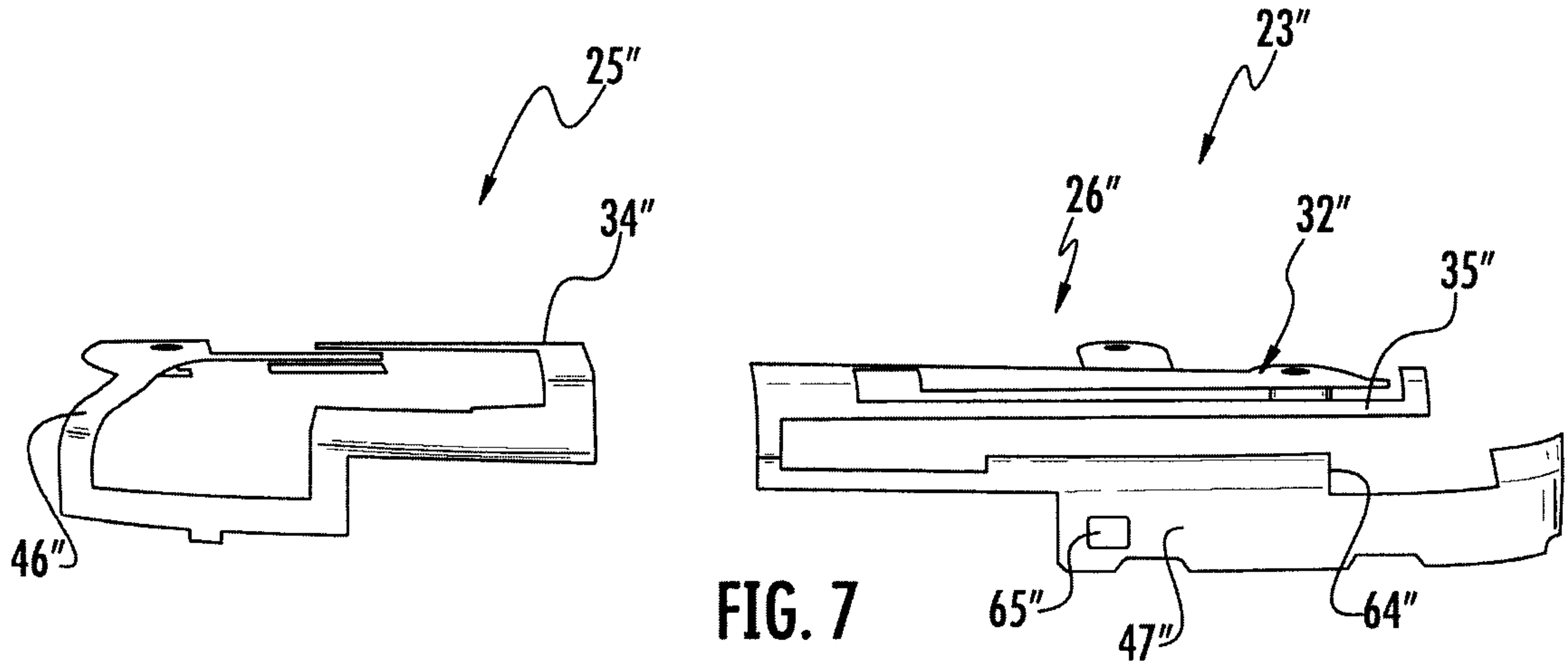
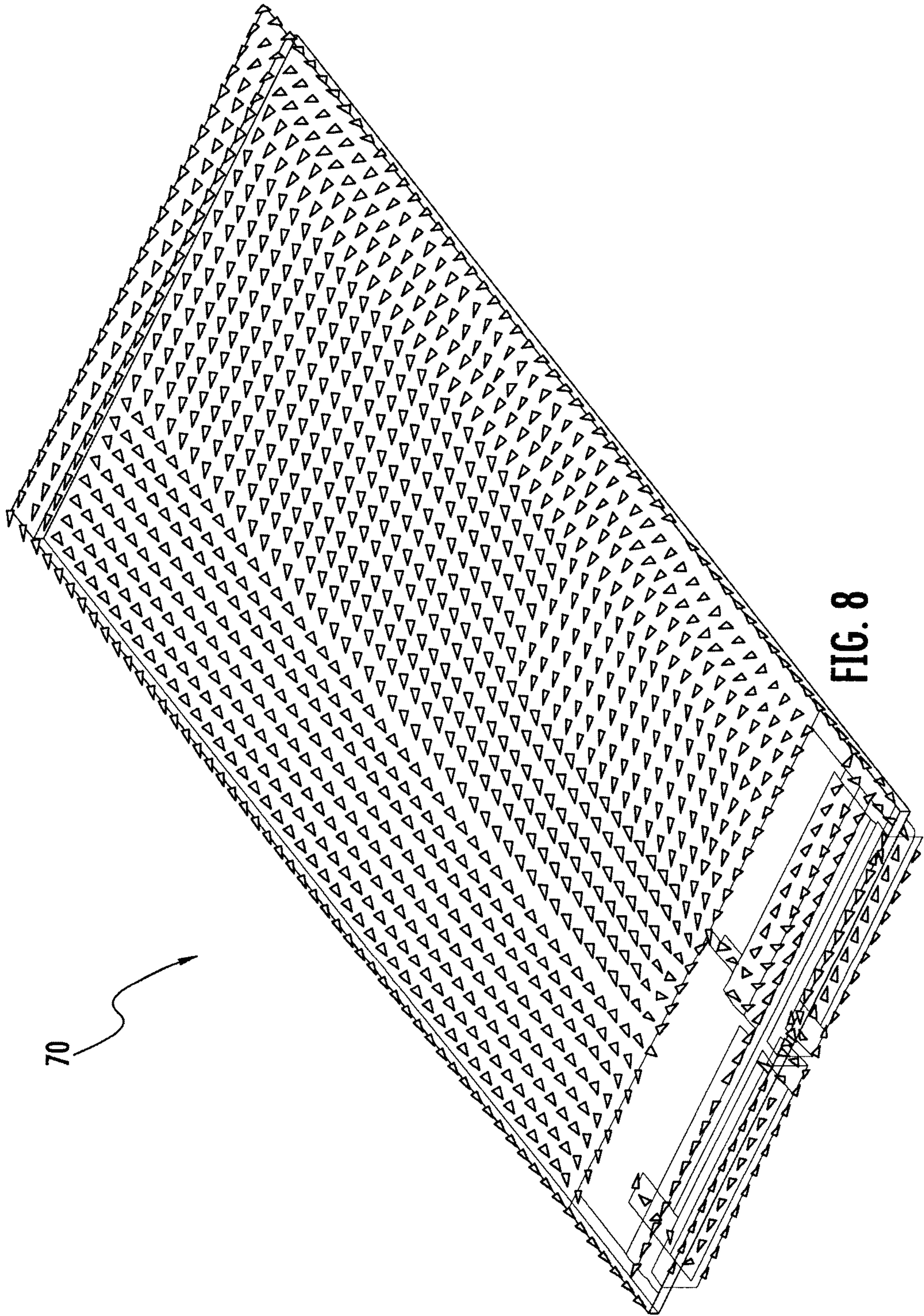

FIG. 7





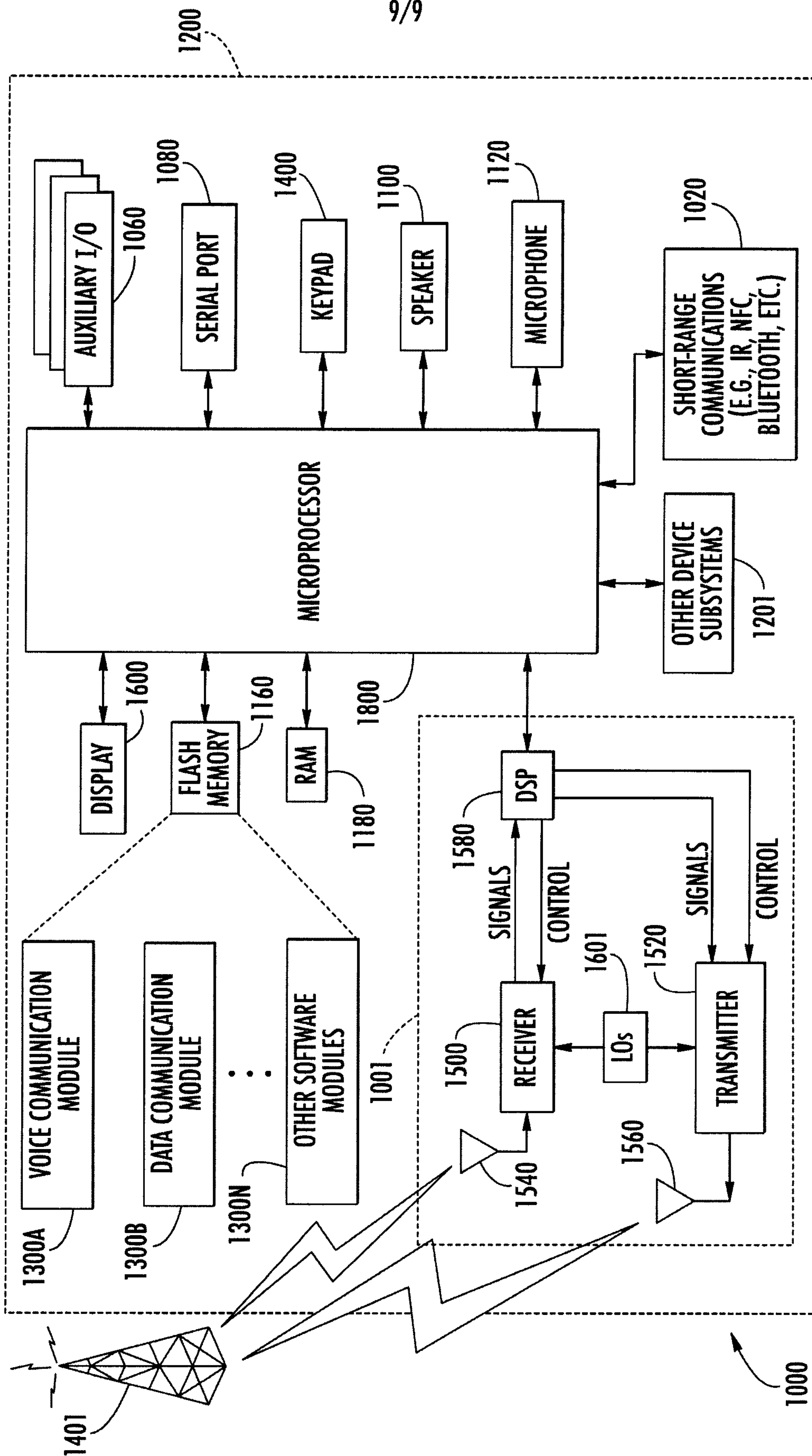

FIG. 12



20

**MOBILE WIRELESS  
COMMUNICATIONS DEVICE**



56

21

55

22

**MULTIPLE-BAND ANTENNA**

**(DIELECTRIC SUBSTRATE AND A PATTERN  
OF ELECTRICALLY CONDUCTIVE TRACES  
THEREON DEFINING A PRIMARY RADIATOR  
AND A SECONDARY RADIATOR SPACED  
APART FROM THE PRIMARY RADIATOR)**

23