

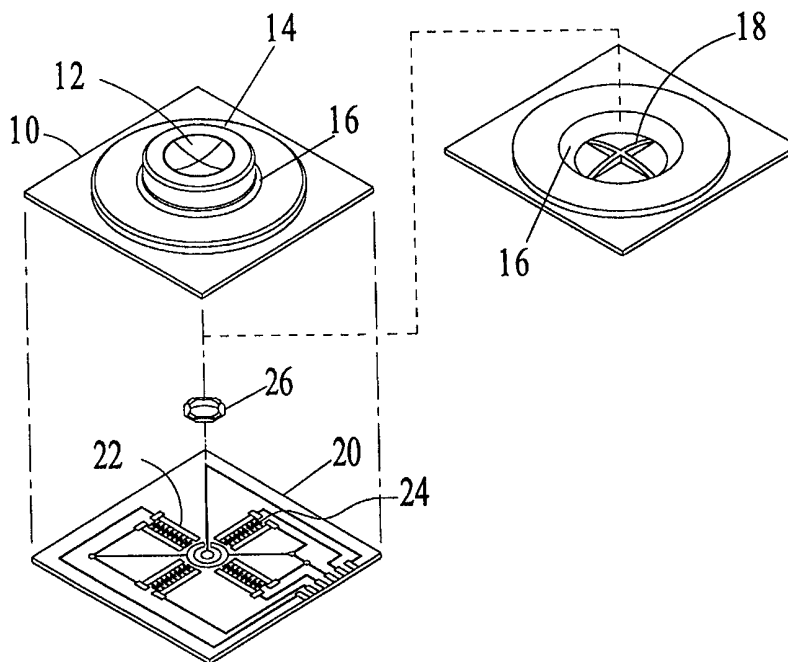

INTERNATIONAL APPLICATION PUBLISHED UNDER THE PATENT COOPERATION TREATY (PCT)

<p>(51) International Patent Classification ⁶ : H01C 10/06</p>	<p>A1</p>	<p>(11) International Publication Number: WO 99/19887 (43) International Publication Date: 22 April 1999 (22.04.99)</p>
<p>(21) International Application Number: PCT/US98/21482 (22) International Filing Date: 12 October 1998 (12.10.98) (30) Priority Data: 60/061,825 14 October 1997 (14.10.97) US 09/096,301 31 May 1998 (31.05.98) US (71)(72) Applicant and Inventor: DEVOLPI, Dean, R. [US/US]; 629 Lariat Unit B, Incline Village, NV 89450 (US). (74) Agent: QUINN, William, J.; Suite 102, 5931 South Middlefield Road, Littleton, CO 80123 (US).</p>		<p>(81) Designated States: AL, AM, AT, AU, AZ, BA, BB, BG, BR, BY, CA, CH, CN, CU, CZ, DE, DK, EE, ES, FI, GB, GD, GE, GH, GM, HR, HU, ID, IL, IS, JP, KE, KG, KP, KR, KZ, LC, LK, LR, LS, LT, LU, LV, MD, MG, MK, MN, MW, MX, NO, NZ, PL, PT, RO, RU, SD, SE, SG, SI, SK, SL, TJ, TM, TR, TT, UA, UG, UZ, VN, YU, ZW, ARIPO patent (GH, GM, KE, LS, MW, SD, SZ, UG, ZW), Eurasian patent (AM, AZ, BY, KG, KZ, MD, RU, TJ, TM), European patent (AT, BE, CH, CY, DE, DK, ES, FI, FR, GB, GR, IE, IT, LU, MC, NL, PT, SE), OAPI patent (BF, BJ, CF, CG, CI, CM, GA, GN, GW, ML, MR, NE, SN, TD, TG). Published <i>With international search report.</i></p>

(54) Title: SEGMENT ANALOG POINTING DEVICE



(57) Abstract

A low-cost pad (14) pointing device with improved performance, reliability and durability, that can be used as a cursor pointing device for computers, remote controls, web TV, TV guide browsers, video games, consumer electronics, industrial controllers, medical, automotive and other applications. A protruding plus shaped segment (18) can be deflected to positions on an electrical medium (20) that results in the generation of a speed and direction signal to be interpreted by low cost available circuitry including microcontrollers.

FOR THE PURPOSES OF INFORMATION ONLY

Codes used to identify States party to the PCT on the front pages of pamphlets publishing international applications under the PCT.

AL	Albania	ES	Spain	LS	Lesotho	SI	Slovenia
AM	Armenia	FI	Finland	LT	Lithuania	SK	Slovakia
AT	Austria	FR	France	LU	Luxembourg	SN	Senegal
AU	Australia	GA	Gabon	LV	Latvia	SZ	Swaziland
AZ	Azerbaijan	GB	United Kingdom	MC	Monaco	TD	Chad
BA	Bosnia and Herzegovina	GE	Georgia	MD	Republic of Moldova	TG	Togo
BB	Barbados	GH	Ghana	MG	Madagascar	TJ	Tajikistan
BE	Belgium	GN	Guinea	MK	The former Yugoslav Republic of Macedonia	TM	Turkmenistan
BF	Burkina Faso	GR	Greece			TR	Turkey
BG	Bulgaria	HU	Hungary	ML	Mali	TT	Trinidad and Tobago
BJ	Benin	IE	Ireland	MN	Mongolia	UA	Ukraine
BR	Brazil	IL	Israel	MR	Mauritania	UG	Uganda
BY	Belarus	IS	Iceland	MW	Malawi	US	United States of America
CA	Canada	IT	Italy	MX	Mexico	UZ	Uzbekistan
CF	Central African Republic	JP	Japan	NE	Niger	VN	Viet Nam
CG	Congo	KE	Kenya	NL	Netherlands	YU	Yugoslavia
CH	Switzerland	KG	Kyrgyzstan	NO	Norway	ZW	Zimbabwe
CI	Côte d'Ivoire	KP	Democratic People's Republic of Korea	NZ	New Zealand		
CM	Cameroon		Republic of Korea	PL	Poland		
CN	China	KR	Republic of Korea	PT	Portugal		
CU	Cuba	KZ	Kazakstan	RO	Romania		
CZ	Czech Republic	LC	Saint Lucia	RU	Russian Federation		
DE	Germany	LI	Liechtenstein	SD	Sudan		
DK	Denmark	LK	Sri Lanka	SE	Sweden		
EE	Estonia	LR	Liberia	SG	Singapore		

SEGMENT ANALOG POINTING DEVICE**Field of the Invention**

The present invention relates in general to multi
5 speed multi direction pointing devices, and more
specifically, to an improved multi speed multi direction
analog pad pointing device.

Background of the Invention

10 In the known art pointing devices are utilized in
connection with computers, video game controls, hand held
remote controls, web TV controls, consumer electronic
controls, industrial controllers, medical equipment,
automotive equipment and other similar applications.
15 With such pointing devices, the user is allowed to
readily control the speed and directional input and make
selections within a particular application utilizing a
single control. It is the objective of such pointing
devices to provide a rapid and effortless means of
20 control in an application and minimize fatigue and the
amount of interrupted action required of the user.

Representative pointing devices of the known art and
their shortcomings will now be described.

25 U.S. Patent No. 4,352,084 to Graves et al discloses
a variable resistor with a substrate that has various
conductive and resistive regions for varied output. The
drawback of such device being that is not capable of dual
X-Y axis output.

30 U.S. Patent No. 4,864,272 to Cecchi et al discloses
a joystick controller utilizing a sliding contact on
resistive and conductive regions that are parallel to one

another and perpendicular to the center of the axis of movement. The drawback to this method of creating an output that may be interpreted into speed and direction, is that operational contact results in abrasion of the resistive and conductive regions as well as requiring many components to accomplish the variable resistive output.

U.S. Patent No. 5,498,843 to Date et al discloses a pivoting digital only pointing device that makes contact in the direction of a direct axis. Date teaches the use of a single speed and eight directions. Date does not teach the use of resistive regions for variable speeds and increased variability of direction. The resultant drawback being that the Date device is limited in variability of speed and direction.

U.S. Patent No. 4,896,003 to Hsieh discloses a pivoting pad, digital only, pointing device that makes contact in the direction of a direct axis. Hsieh also teaches the use of parallel conductive digital traces that extend perpendicularly from the center. The resultant drawback being that the Hsieh device is limited in its number of digital contacts due to congestion; thus, it is impractical to provide a device having a greatly variable number of speeds and directions.

U.S. Patent No. 5,488,206 to Wu discloses the use of conductive rubber and membrane switches in a digital fashion to supply speed and directional output; and is therefore limited to providing a small number of speeds.

U.S. Patent No. 5,376,913 to Pine et al discloses the use of a solid conductive curved disc and that a single resistor can be contacted to affect a change in

resistance. The drawback to the Pine device being that, Pine does not anticipate the use multiple resistors for pointing or the use of just a segment of the conductive disc to minimize costs.

5 U.S. Patent No. 5,675,309 to DeVolpi discloses the use of a continuous curved disc that pivots on a substrate that has resistive and conductive elements completely covering or surrounding the center of a printed circuit board in a continuous 360 degree area.
10 The drawbacks to the DeVolpi device being that directions other than the true axis are hard to control for infinite controlled proportional resolution due to the footprint of the conductive rubber disc; and truly consistent varied angles cannot be achieved. Further,
15 the solid conductive curved disc is the most expensive component of the disclosed technology.

Finally, U.S. Patent No. 5,278,557 to Stokes et al discloses a force-sensitive variable resistor that operates using triangulation. The drawback to this
20 method of providing a speed and direction output is that a polymer force-sensitive material is utilized, and the inherent properties of such a material result in having to apply excessive force to get an increased speed output, which in extended use can cause fatigue in the
25 user.

Accordingly it is the object of the present invention to provide an improved multi speed multi direction analog pad pointing device eliminating the shortcomings of the above identified known art, and which can be mass
30 produced and assembled with consistent quality at a cost comparable to a conventional pointing device, requiring a

reduced amount of effort in operation and having greater resolution and variability of speed and directional output.

5

Summary of the Invention

The objects of the present invention are attained by a multi speed multi direction pad pointing device which uses a top cover, which on its bottom, has an elastic protruding plus shaped segment which is either electrically conductive or resistive on its bottom surface and has a number of ribs which radiate out from its center at various angles. The top cover is formed with an elastic return ridge that encircles the protruding plus shaped segment and may be caused to bend and flex when in operation. A substrate such as a printed circuit board, glass, paper, ceramic or plastic which has conductive lines and resistive coatings formed on it or embedded within it, homogeneous throughout or likewise provided on the surface is positioned below the plus shaped segment of the top cover. Force is applied in operation to deform the return ridge and cause the plus shaped segment to move downward and tilt in orientation so that contact is made with the conductive or resistive tracts of the substrate in a location corresponding to the direction and degree of the force applied such that an output signal is provided that may be translated by analog to digital or RC timing circuitry into speed and direction vectors. As the plus shaped segment is elastic, once contact is made between the plus shaped segment and the substrate, additional downward force may be utilized to deform the plus shaped segment

and provide fine resolution control. Finally, as the return ridge is elastic, the plus shaped segment returns to its unbiased position when force is removed in operation.

5

The objects of the present invention are also attained by an alternative embodiment of the present invention, which utilizes a top cover, which on its bottom, has an elastic protruding plus shaped segment which has a number of ribs which radiate out from its center at various angles. The top cover is formed with an elastic return ridge that encircles the protruding plus shaped segment and may be caused to bend and flex when in operation. A membrane switch is placed below the protruding plus shaped segment and has resistive and conductive surfaces facing each other with dielectrics to prevent the resistive and conductive surfaces from making contact in the unbiased position. Force is applied in operation to deform the return ridge and cause the plus shaped segment to move downward and tilt in orientation so that contact is made with the membrane causing contact to be made between conductive and resistive surfaces in a location corresponding to the direction and degree of the force applied such that an output signal is provided that may be translated by analog to digital or RC timing circuitry into speed and direction vectors. As the plus shaped segment is elastic, once contact is made between the plus shaped segment and the membrane switch, additional downward force may be utilized to deform the plus shaped segment, thereby varying the contact made between the conductive and resistive regions of the

10

15

20

25

30

membrane switch and provide fine resolution control. Finally, as the return ridge is elastic, the plus shaped segment returns to its unbiased position when force is removed in operation.

5 It can be observed from the present invention, that by utilizing an elastic return ridge to control the contact position of the protruding plus shaped segment with the substrate, and also to return the present invention to its unbiased position, the amount of force
10 required of the operator is minimized, resulting in increased control and decreased fatigue for the operator over extended periods of continued use. Further, as the present invention may utilize continuous resistive tracts or surfaces, the number of directions is increased, and
15 the number of speeds is limited only by the analog to digital circuitry employed. Still further, as the protruding plus shaped segment is sectioned into a number of ribs radiating from its center, the amount of conductive rubber is reduced, reducing the cost
20 accordingly. Additionally, the small number of simple component parts will allow the present invention to be mass produced at a consistent quality and uniformity at no additional manufacturing cost to a conventional remote control.

25 Other objects, advantages and novel features of the present invention will become apparent from the following drawings and detailed description of the preferred embodiments.

30

Brief Description of the Drawings

FIG. 1 is an exploded perspective view of the present invention displaying the cover with a dimple, dome switch and substrate.

5 FIG. 2 is a perspective view of the bottom of the cover shown in FIG. 1 displaying the protruding plus shaped segment.

FIG. 3 is a plan view of the substrate shown in FIG. 1 displaying the resistive and conductive paths thereon.

10 FIG. 4 is sectional view of the present invention shown in FIG. 1.

FIG. 5 is a perspective view of the bottom of the cover displaying a modified non-continuous form of the protruding plus shaped segment.

15 FIG. 6. is a plan view of the substrate with a modified layout of the resistive and conductive paths thereon.

FIG. 7 is a plan view of the substrate with a modified layout of the resistive and conductive paths thereon.

20 FIG. 8 is an exploded perspective view of a modified form of the present invention utilizing a membrane switch as the substrate.

25 FIG. 9 is a sectional view of the present invention shown in FIG. 8 with a modified form of the cover incorporating a built in switch button.

FIG. 10 is a plan view of the membrane switch and the resistive and conductive paths and dielectrics thereon.

30 FIG. 11 is a sectional view of the present invention displaying a modified form of the protruding plus shaped segment which is recessed to accommodate the dome switch.

FIG. 12 is a plan view of the substrate with a modified layout of the resistive and conductive paths thereon.

5 FIG. 13 is a plan view of the substrate with a modified layout of the resistive and conductive paths thereon.

10 FIG. 14 is a sectional view of the present invention displaying a modified form of the cover having conductive legs extending from the protruding plus shaped segment and electrically contacting the substrate.

FIG. 15 is a perspective view of the bottom of the cover shown in FIG. 14 displaying the conductive legs extending from the protruding plus shaped segment.

15 FIG. 16 is a plan view of the substrate with a modified layout of the resistive and conductive paths thereon which incorporate contacts for the conductive legs of the cover shown in FIG. 15.

Detailed Description of the Preferred Embodiments

20 The present invention will now be described with reference to FIGS. 1 through 4.

25 The pad pointing device of the present invention shown in FIGS. 1 through 4 comprises a cover 10, which on its top surface has a dimple 12 formed within the top of the pad 14, wherein a finger may be placed within dimple 12 of pad 14 to apply compression and tilting forces in operation of the pad pointing device. Cover 10 is formed with a return ridge 16 surrounding pad 14, which may be caused to bend and flex when external force is applied to pad 14 through dimple 12, and which causes pad 14 to
30 return to an unbiased position when such external force

is removed from pad **14**. Further, cover **10** has a protruding plus shaped segment **18** formed on or attached to its bottom surface directly below dimple **12** and encircled within return ridge **16**; protruding plus shaped segment **18** is shaped with a number of ribs which radiate out from its center at various angles and is preferably formed of an elastic material that may be deformed when a force is applied. The lower surface of protruding plus shaped segment **18** is electrically conductive or resistive. The pad pointing device further comprises a substrate **20** which has resistive regions **22** and conductive regions **24** formed on or within its upper surface. The conductive regions **24** are electrically connected to resistive regions **22** and are arranged in an alternating ladder fashion of contacts radiating out from the center of substrate **20** at various angles. The substrate **20** is positioned with its upper surface facing the bottom surface of cover **10** in such orientation that the conductive regions **24** are directly below the ribs of protruding plus shaped segment **18**. A dome switch **26** rests on the center of the upper surface of substrate **20** and provides a tactile feel when downward force is applied to pad **14** and transmitted through protruding plus shaped segment **18** to dome switch **26** which in application can be used to provide an electrical switch signal.

In operation of the present invention as shown in FIGS. **1** through **4**, when an external force is applied by an operator's finger in dimple **12** tangent to the focal point of dimple **12** of pad **14**, the force is transmitted through pad **14** of cover **10** deforming return ridge **16** thereby causing a rocking and downward movement of

protruding plus shaped segment **18** resulting in the lower surface of protruding plus shaped segment **18** making physical contact with substrate **20** and shorting at least on conductive region **24** contact with an opposing
5 conductive region **24** contact thereby a signal of measurable resistance. As the external force applied is varied in force or direction, the location of the contact made on the conductive regions **24** correspondingly changes resulting in a corresponding change in measurable
10 resistance which may be translated by analog to digital or RC timing circuitry into speed and direction vectors. Additionally, variation in the degree of downward external force applied can be utilized for refined resolution as the protruding plus shaped segment **18** may
15 be made of elastic type material. When the external force is removed, the potential energy stored in return ridge **16** from the application of the force is utilized to return pad **14**, and thus protruding plus shaped segment **18** to the unbiased position wherein no contact is made
20 between protruding plus shaped segment **18** and conductive regions **24**. When sufficient downward force is applied through dimple **12** and transmitted through protruding plus shaped segment **18** compressing dome switch **26**, the operator is provided with a tactile feel. Additionally
25 compression of the dome switch may be utilized to provide a selection switch, in the same manner as a button provided on a computer mouse for selection.

In FIG. **5** a modified form of the cover **10** is illustrated with a non-continuous protruding plus shaped
30 segment **28** with a recess provided in the center of the

non-continuous protruding plus shaped segment which would allow dome switch **26** to be recessed.

FIG. **6** illustrates a modified form of the substrate **20** with continuous resistive regions **22** arranged directly below the ribs of protruding plus shaped segment **18** and where a potential voltage is applied to the lower surface of protruding plus shaped segment **18** through a dome switch **26** in contact with conductive region **24**. In operation, when an external force is applied in dimple **12** tangent to the focal point of dimple **12** of pad **14**, the force is transmitted through pad **14** of cover **10** deforming return ridge **16** and thereby causes a rocking and downward movement of protruding plus shaped segment **18** resulting in the lower surface of protruding plus shaped segment **18** making physical and electrical contact with at least one resistive region **22** of substrate **20**. And since a potential voltage is applied to the lower surface of protruding plus shaped segment **18**, a signal of measurable resistance which may be translated into speed and directional vectors is therefore provided corresponding to the amount and direction of the force applied.

FIG. **7** illustrates a modified form of the substrate **20** with resistive regions **22** and conductive regions **24** arranged adjacent to each other, with each pair of resistive region **22** and conductive region **24** arranged directly below the ribs of protruding plus shaped segment **18**. In operation, when an external force is applied in dimple **12** tangent to the focal point of dimple **12** of pad **14**, the force is transmitted through pad **14** of cover **10** deforming return ridge **16** and thereby causes a rocking and downward movement of protruding plus shaped segment

18 resulting in the lower surface of protruding plus shaped segment 18 making physical contact with substrate 20 and thereby shorting together at least one pair of resistive region 22 and conductive region 24 at a location corresponding to the amount and direction of the force applied. Consequently, a signal of measurable resistance is established which may be translated into speed and directional vectors.

An alternate embodiment of the present invention will now be described with reference to FIGS. 8 through 10.

An alternate embodiment of the pad pointing device of the present invention shown in FIGS. 8 through 10 comprises a cover 10, which on its top surface has a dimple 12 formed within the top of the pad 14, wherein a finger may be placed within dimple 12 of pad 14 to apply compression and tilting forces in operation of the pad pointing device. An integrated button is also provided within dimple 12 of pad 14. Cover 10 is formed with a return ridge 16 surrounding pad 14, which may be caused to bend and flex when external force is applied to pad 14 through dimple 12, and which causes pad 14 to return to an unbiased position when such external force is removed from pad 14. Further, cover 10 has a protruding plus shaped segment 18 formed on or attached to its bottom surface directly below dimple 12 and encircled within return ridge 16; protruding plus shaped segment 18 is shaped with a number of ribs which radiate out from its center at various angles and is preferably formed of an elastic material that may be deformed when a force is applied. The pad pointing device further comprises a

membrane switch **30** which has resistive regions **22** and
conductive regions **24** formed on or within its top surface.
The resistive regions **22** and the conductive regions **24**
are arranged on membrane switch **30** in such orientation
5 that when assembled they are situated directly below the
ribs of protruding plus shaped segment **18**. In assembled
fashion, the membrane switch **30** is folded over upon
itself so that resistive regions **22** are aligned with and
are facing conductive regions **24** and a rigid backer
10 surface **32** is placed under membrane switch **30**.
Dielectrics **36** are provided for on the surface of
membrane switch **30** to prevent the membrane switch **30**
surfaces from making contact in the unbiased position. A
digital wake-up switch contact **38** is also provided in the
15 center of the resistive regions **22**.

In operation of the alternate embodiment of the
present invention as shown in FIGS. **8** through **10**, when an
external force is applied by an operator's finger in
dimple **12** the force is transmitted through pad **14** of
20 cover **10** deforming return ridge **16** thereby causing a
rocking and downward movement of protruding plus shaped
segment **18** resulting in the lower surface of protruding
plus shaped segment **18** making physical contact with the
outside surface of the membrane switch **30** which is
25 supported by rigid backer surface **32**. The physical
contact that is made by the protruding plus shaped
segment **18** presses the two layers of the membrane switch
30 together, which shorts at least one of the conductive
regions **24** with its opposing resistive region **22** at a
30 position corresponding to the direction of the force
applied. The shorting of the conductive region **24** with

its opposing resistive region **22**, completes a circuit causing a variable resistance. The greater the force applied in a given direction the further out from the center of substrate **20** the short occurs, corresponding to a measurable change in resistance. To effect refined movement, varying force may be utilized in a perpendicular compressive fashion to the membrane switch **30**. The output resistance is interpreted by analog to digital or RC timing circuitry into speed and direction vectors. When the external force is removed, the potential energy stored in return ridge **16** from the application of the force is utilized to return pad **14**, and thus protruding plus shaped segment **18** to the unbiased position wherein no contact is made between protruding plus shaped segment **18** and membrane switch **30**.

In FIG. **11** a modified form of the cover **10** is illustrated with a continuous protruding plus shaped segment **18** with a recess provided in the center of the continuous protruding plus shaped segment which would allow dome switch **26** to be recessed.

FIG. **12** illustrates a modified form of the substrate **20** which has a digital wake-up switch contact **38** at its center and has resistive regions **22** and conductive regions **24** formed on or within its upper surface. The conductive regions **24** are arranged in an alternating ladder fashion of contacts radiating out from the center of substrate **20** at various angles. Each alternating contact in a conductive region **24** is electrically connected to a resistive region **22** at a location corresponding to its distance from the center of substrate **20**. In use, the substrate **20** is to be

positioned with its upper surface facing the bottom surface of cover **10** in such orientation that the conductive regions **24** are directly below the ribs of protruding plus shaped segment **18**.

5 FIG. **13** illustrates a modified form of the substrate **20** which has a digital wake-up switch contact **38** at its center and has resistive regions **22** and conductive regions **24** formed on or within its upper surface. The conductive regions **24** are arranged in a ladder fashion of
10 contacts radiating out from the center of substrate **20** at various angles. Each contact in a conductive region **24** is electrically connected to a resistive region **22** at a location corresponding to its distance from the center of substrate **20**. The conductive regions **24** are arranged
15 directly below the ribs of protruding plus shaped segment **18**. A potential voltage is applied to the lower surface of protruding plus shaped segment **18**. In operation, when an external force is applied in dimple **12** tangent to the focal point of dimple **12** of pad **14**, the force is
20 transmitted through pad **14** of cover **10** deforming return ridge **16** and thereby causes a rocking and downward movement of protruding plus shaped segment **18** resulting in the lower surface of protruding plus shaped segment **18** making physical and electrical contact with at least one
25 of the conductive regions **24** of substrate **20**. And as a potential voltage is applied to the lower surface of protruding plus shaped segment **18**, a signal of measurable resistance which may be translated into speed and directional vectors is therefore provided corresponding
30 to the amount and direction of the force applied.

FIGS. 14 through 16 illustrate a modified form of the present invention. In this modified form of the present invention cover 10, on its top surface has a dimple 12 formed within the top of the pad 14, wherein a finger may be placed within dimple 12 of pad 14 to apply compression and tilting forces in operation of the pad pointing device. Cover 10 is formed with a return ridge 16 surrounding pad 14, which may be caused to bend and flex when external force is applied to pad 14 through dimple 12, and which causes pad 14 to return to an unbiased position when such external force is removed from pad 14. Further, cover 10 has a protruding plus shaped segment 18 formed on or attached to its bottom surface directly below dimple 12 and encircled within return ridge 16; protruding plus shaped segment 18 is shaped with a number of ribs which radiate out from its center at various angles and is preferably formed of an elastic material that may be deformed when a force is applied. The lower surface of protruding plus shaped segment 18 is electrically conductive or resistive. A conductive leg 40, formed on or within cover 10, and in electrical contact with the lower surface of protruding plus shaped segment 18, extends outward and beyond the return ridge 16 toward the periphery of cover 10 from each rib of protruding plus shaped segment 18. Additionally, in this modified version of the present invention the substrate 20 has a digital wake-up switch contact 38 at its center and has resistive regions 22 and conductive regions 24 and leg contact points 42 formed on or within its upper surface. The conductive regions 24 are arranged in a ladder fashion of contacts radiating

out from the center of substrate **20** at various angles. Each leg contact point **42** is positioned such that when the substrate **20** is fitted below the cover **10** conductive legs **40** are in electrical contact with leg contact points **42**. Each contact in a conductive region **24** is electrically connected to a resistive region **22** at a location corresponding to its distance from the center of substrate **20**. The conductive regions **24** are arranged directly below the ribs of protruding plus shaped segment **18**.

In operation of the modified form of the present invention as illustrated in FIGS. **14** through **16**, a potential voltage is applied to the lower surface of protruding plus shaped segment **18** by electrical contact through conductive legs **40** which are in electrical contact with leg contact points **42**. When an external force is applied in dimple **12** tangent to the focal point of dimple **12** of pad **14**, the force is transmitted through pad **14** of cover **10** deforming return ridge **16** and thereby causes a rocking and downward movement of protruding plus shaped segment **18** resulting in the lower surface of protruding plus shaped segment **18** making physical and electrical contact with at least one of the conductive regions **24** of substrate **20**. As a potential voltage has been applied to the lower surface of protruding plus shaped segment **18**, a signal of measurable resistance which may be translated into speed and directional vectors is therefore provided corresponding to the amount and direction of the force applied.

Although the detailed description of the drawings is directed toward illustrating the above described embodiments, the present invention is not limited to such embodiments, as variations and modifications may be made
5 without departing from the scope of the present invention as claimed herein.

What is claimed is:

1. A multi-speed multi-direction analog pointing device comprising:

- 5 a plus shaped upper contact having a central axis and having a number of ribs which radiate out from said central axis, and further wherein said upper contact has a bottom surface, and further wherein said bottom surface is electrically conductive;
- 10 a substrate having an upper surface arranged below said upper contact and having a plurality of electrical contact points on said upper surface situated below said bottom surface of said plus shaped upper contact and aligned with said ribs; and
- 15 displacement means for tilting and downwardly moving said plus shaped upper contact wherein said displacement means has an undeflected position and may be variably deflected when an external force is applied whereby electrical contact is made between said bottom surface of said plus
- 20 shaped upper contact and at least one of said electrical contact points at a position corresponding to the direction and intensity of said external force.

- 25 2. The multi-speed multi-direction analog pointing device according to claim 1, wherein said displacement means comprises a cover, to which said plus shaped upper contact is attached, and a return ridge surrounding said plus shaped upper contact wherein said return ridge is elastic and which is deformed upon application of said
- 30 external force, tilting and downwardly moving said plus shaped upper contact in a direction and distance

corresponding to the direction and intensity of said external force.

5 3. The multi-speed multi-direction analog pointing device according to claim 2, wherein said plus shaped upper contact is elastic and which is variably deformed when in contact with said upper surface of said substrate by application of additional external force in a downward direction thereby creating electrical contact between
10 said bottom surface of said plus shaped upper contact and said upper surface of said substrate at a number of said electrical contact points corresponding to the intensity of said additional external force in a downward direction.

15

 4. The multi-speed multi-direction analog pointing device according to claim 2, wherein said plurality of electrical contact points on said upper surface of said substrate is comprised of continuous strips of resistive
20 material situated below said bottom surface of said plus shaped upper contact and aligned with said ribs.

 5. The multi-speed multi-direction analog pointing device according to claim 2, wherein said bottom surface
25 of said upper contact is resistive.

 6. The multi-speed multi-direction analog pointing device according to claim 2, wherein said bottom surface of said upper contact is convex.

30

7. A multi-speed multi-direction analog pointing device comprising:

a plus shaped upper member having a central axis and having a number of ribs which radiate out from said central axis;

5 a two layered membrane switch having a plurality of electrical contact points on a first layer which face a corresponding plurality of electrical contact points on a second layer, wherein said plurality of electrical contact points on said first layer and said corresponding plurality of electrical contact points on said second layer are situated below said bottom surface of said plus shaped upper member; and further wherein said two layered membrane switch has an undeformed position in which said plurality of electrical contact points on said first layer is separated from said corresponding plurality of electrical contact points on said second layer;

10 displacement means for tilting and downwardly moving said plus shaped upper member wherein said displacement means has an undeflected position and may be variably deflected when an external force is applied whereby contact is made between said bottom surface of said plus shaped upper member and said two layered membrane switch, deforming said two layer membrane switch and causing at least one of said electrical contact points on said first layer to make contact with said corresponding electrical contact point on said second layer at a location corresponding to the direction and intensity of said external force.

15 20 25 30 8. The multi-speed multi-direction analog pointing device according to claim 7, wherein said displacement

means comprises a cover, to which said plus shaped upper member is attached, and a return ridge surrounding said plus shaped upper member wherein said return ridge is elastic and which is deformed upon application of said external force, tilting and downwardly moving said plus shaped upper member in a direction and distance corresponding to the direction and intensity of said external force.

10 9. The multi-speed multi-direction analog pointing device according to claim 8, wherein said plus shaped upper member is elastic and which is variably deformed when in contact with said two layered membrane switch by application of additional external force in a downward direction thereby causing electrical contact to be made between said electrical contact points on said first layer and corresponding electrical contact point on said second layer at a number of locations corresponding to the intensity of said additional external force in a downward direction.

25 10. The multi-speed multi-direction analog pointing device according to claim 8, wherein said plurality of electrical contact points on said first layer is comprised of continuous strips of resistive material situated below said bottom surface of said plus shaped upper contact and aligned with said ribs of said plus shaped upper contact, and wherein said corresponding plurality of electrical contact points on said second layer is comprised of continuous strips of conductive material facing said continuous strips of resistive

material and situated below said bottom surface of said plus shaped upper contact and aligned with said ribs of said plus shaped upper contact.

5 11. The multi-speed multi-direction analog pointing device according to claim 8, wherein said bottom surface of said upper contact is convex

10 12. A multi-speed multi-direction analog pointing device comprising:

a plus shaped upper contact having a central axis and having a number of ribs which radiate out from said central axis, and further wherein said upper contact has a bottom surface, and further wherein said bottom surface is electrically conductive;

15 a substrate having an upper surface arranged below said upper contact and having a first plurality of electrical contact points and a second plurality of electrical contact points, wherein said first plurality of electrical contact points and said second plurality of electrical contact points are located on said upper surface, situated below said bottom surface of said plus shaped upper contact and aligned with said ribs; and displacement means for tilting and downwardly moving said plus shaped upper contact wherein said displacement means has an undeflected position and may be variably deflected when an external force is applied whereby electrical contact is made between said bottom surface of said plus shaped upper contact and at least one of said first electrical contact points and at least one of said second electrical contact points simultaneously at a position

20
25
30

corresponding to the direction and intensity of said external force.

5 13. The multi-speed multi-direction analog pointing device according to claim 12, wherein said displacement means comprises a cover, to which said plus shaped upper contact is attached, and a return ridge surrounding said plus shaped upper contact wherein said return ridge is elastic and which is deformed upon application of said
10 external force, tilting and downwardly moving said plus shaped upper contact in a direction and distance corresponding to the direction and intensity of said external force.

15 14. The multi-speed multi-direction analog pointing device according to claim 13, wherein said plus shaped upper contact is elastic and which is variably deformed when in contact with said upper surface of said substrate by application of additional external force in a downward
20 direction thereby creating electrical contact between said bottom surface of said plus shaped upper contact and said upper surface of said substrate at a number of said first electrical contact points and a number of said second contact points corresponding to the intensity of
25 said additional external force in a downward direction.

 15. The multi-speed multi-direction analog pointing device according to claim 13, wherein said first plurality of electrical contact points on said upper
30 surface of said substrate is comprised of continuous strips of resistive material and said second plurality of

electrical contact points on said upper surface of said substrate is comprised of continuous strips of conductive material, wherein each said continuous strip of resistive material has a companion said continuous strip of conductive material parallel to it wherein each said continuous strip of resistive material and its companion said continuous strip of conductive material are situated below said bottom surface of said plus shaped upper contact and aligned with one of said ribs.

10

16. The multi-speed multi-direction analog pointing device according to claim 13, wherein said first plurality of electrical contact points on said upper surface of said substrate is comprised of first continuous strips of resistive material and said second plurality of electrical contact points on said upper surface of said substrate is comprised of second continuous strips of resistive material, wherein each said first continuous strip of resistive material has a companion second continuous strip of resistive material parallel to it wherein each said first continuous strip of resistive material and its companion second continuous strip of resistive material are situated below said bottom surface of said plus shaped upper contact and aligned with one of said ribs.

15

20

25

17. The multi-speed multi-direction analog pointing device according to claim 13, wherein said bottom surface of said upper contact is resistive

30

18. The multi-speed multi-direction analog pointing device according to claim 13, wherein said bottom surface of said upper contact is convex

1/3

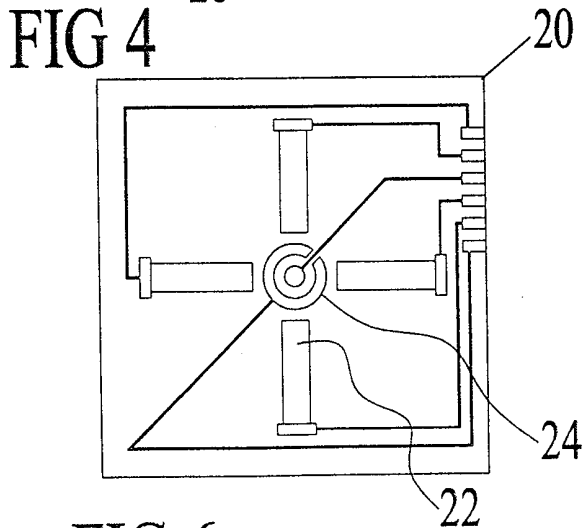
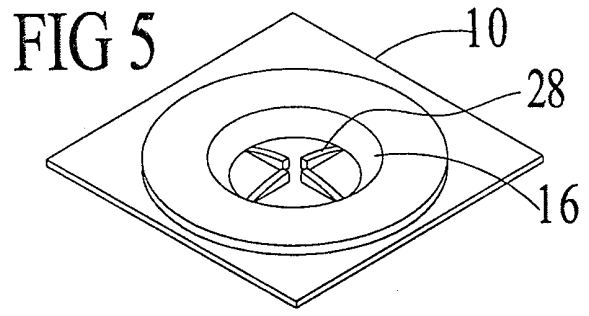
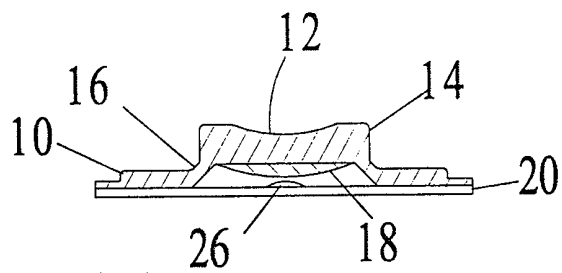
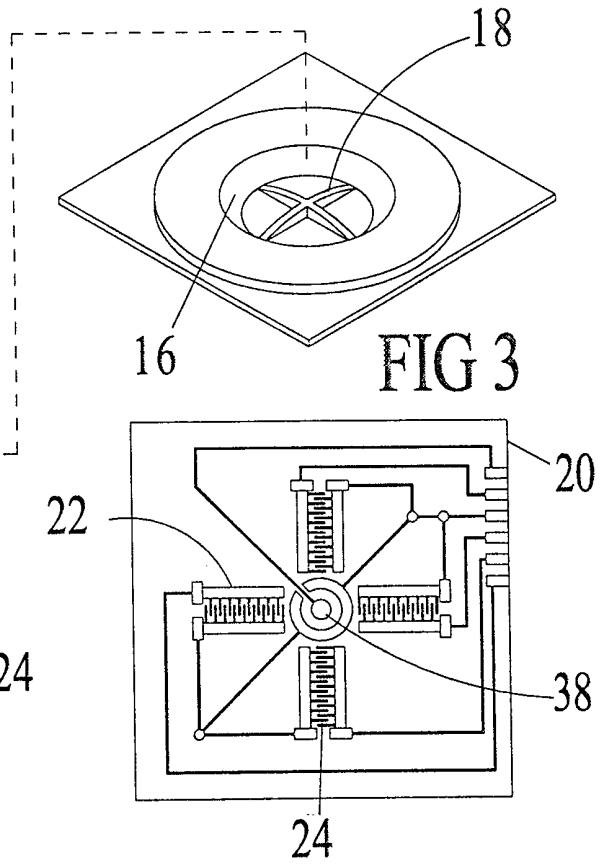
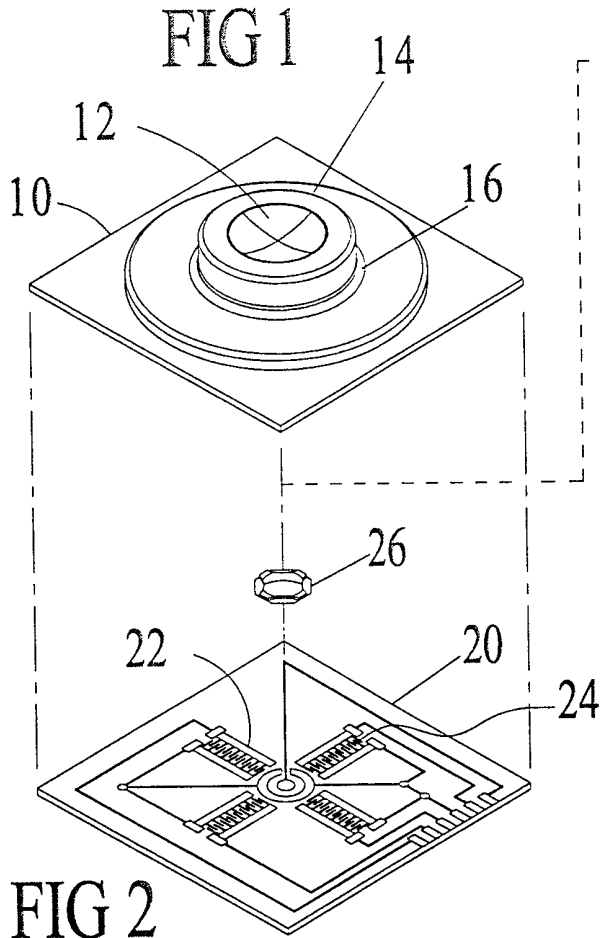

FIG 6

FIG 7

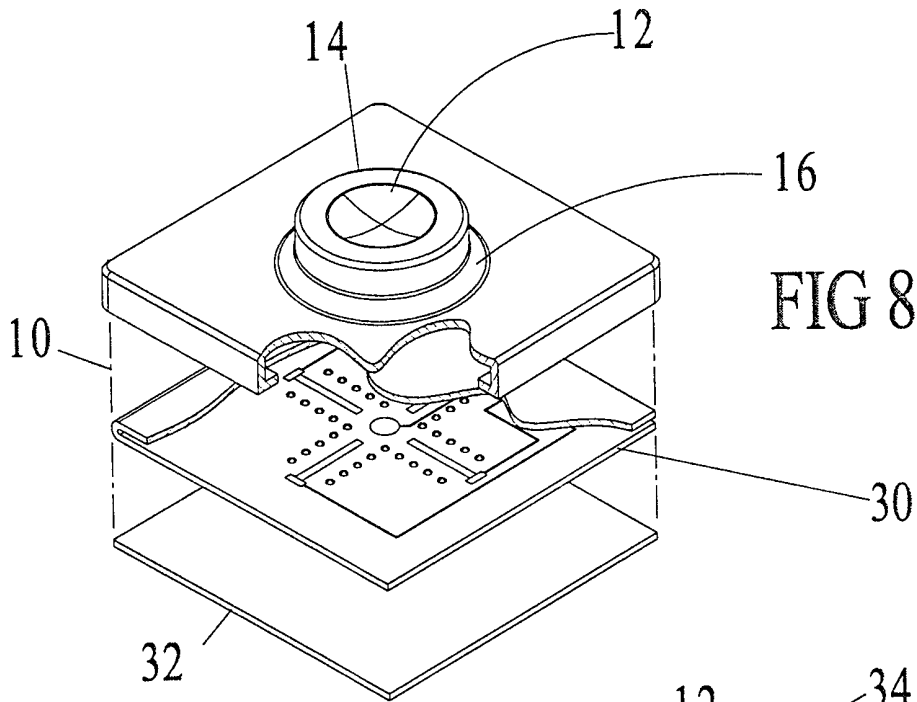

FIG 8

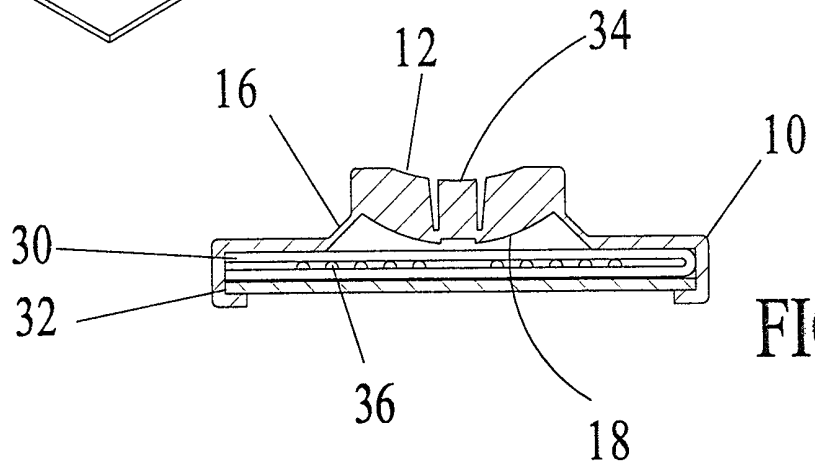

FIG 9

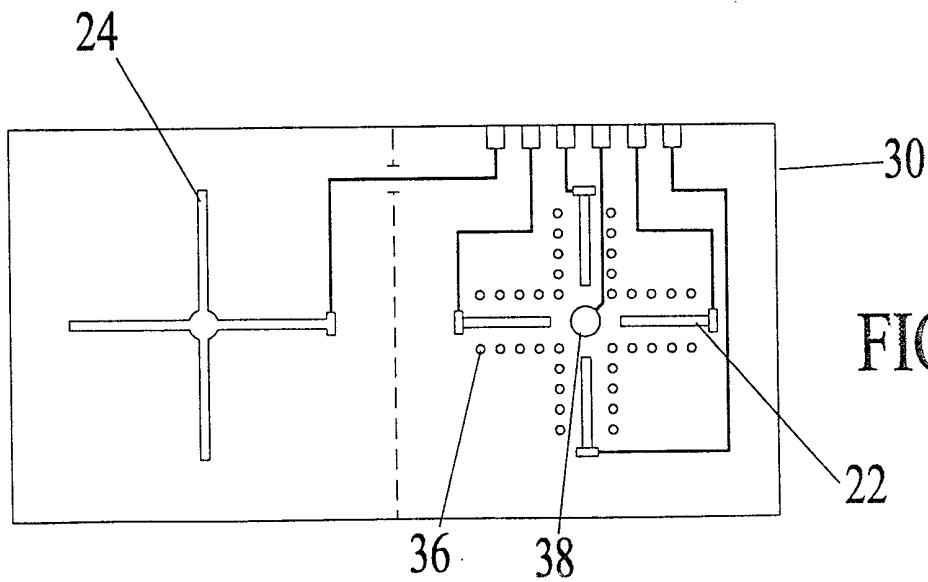
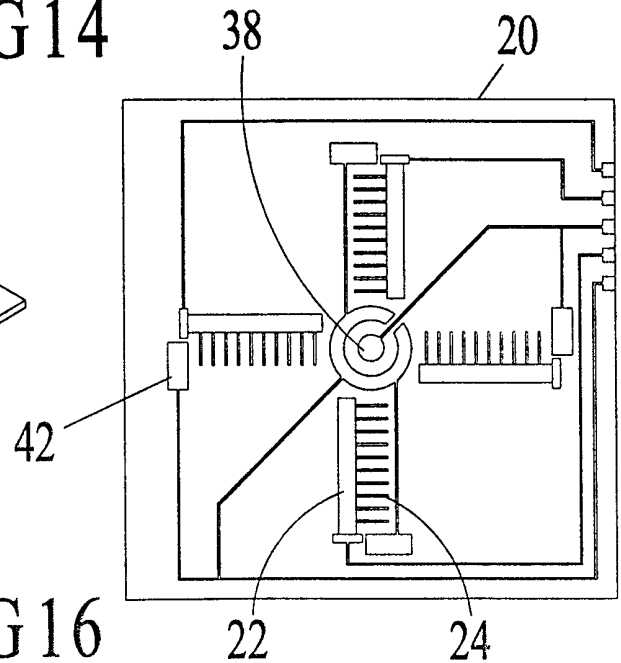
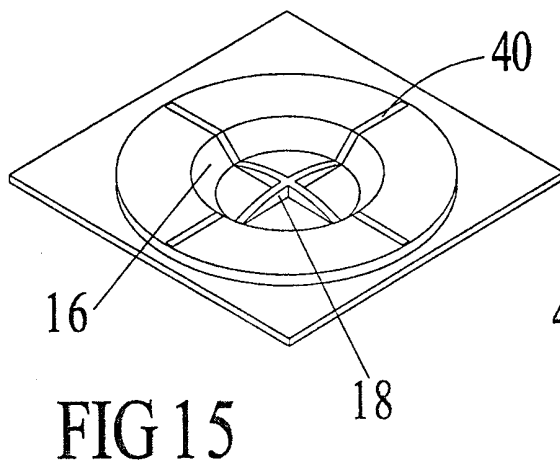
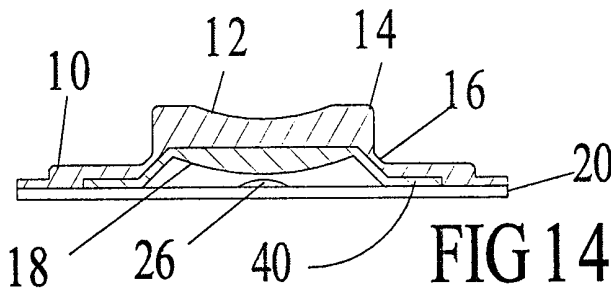
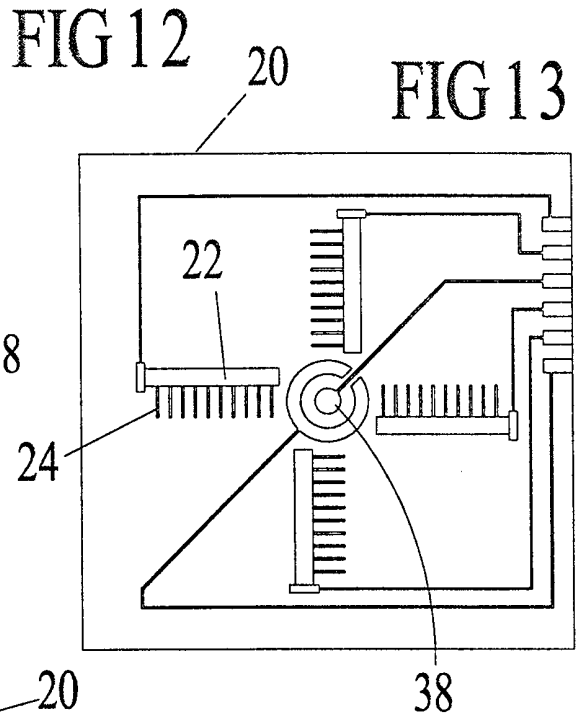
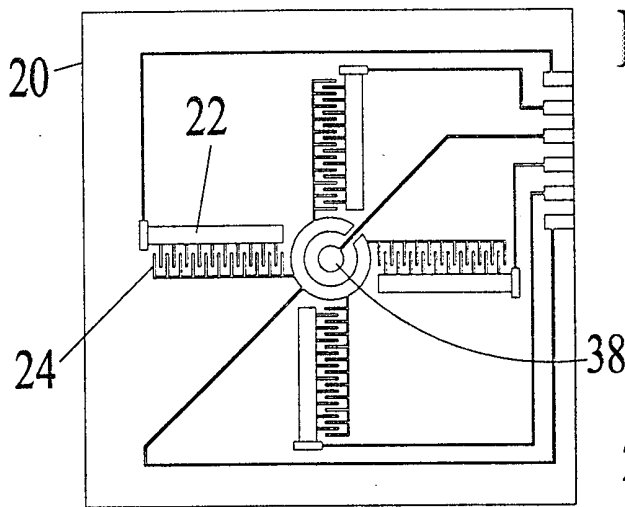
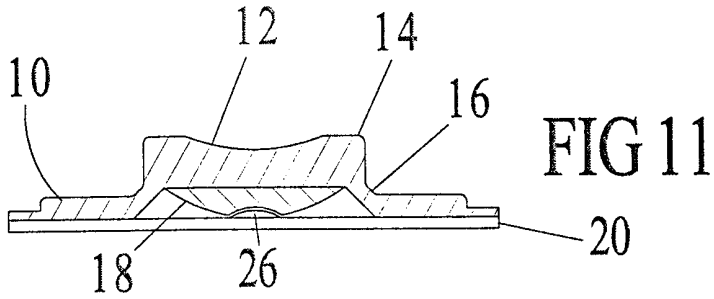

FIG 10

3/3



INTERNATIONAL SEARCH REPORT

International application No.
PCT/US98/21482

A. CLASSIFICATION OF SUBJECT MATTER
 IPC(6) : H01C 10/06
 US CL : 338/95, 96, 97, 99, 114
 According to International Patent Classification (IPC) or to both national classification and IPC

B. FIELDS SEARCHED
 Minimum documentation searched (classification system followed by classification symbols)
 U.S. : 338/95, 96, 97, 99, 114, 92, 93

Documentation searched other than minimum documentation to the extent that such documents are included in the fields searched
 NONE

Electronic data base consulted during the international search (name of data base and, where practicable, search terms used)
 NONE

C. DOCUMENTS CONSIDERED TO BE RELEVANT

Category*	Citation of document, with indication, where appropriate, of the relevant passages	Relevant to claim No.
Y	US 5,550,339 A (HAUGH) 27 August 1996 (27.08.96) col. 4. lines 53-59.	1-4, 7-10, 12-16
Y	US 4,257,305 A (FRIEND et al) 24 March 1981 (24.03.81) col. 2, lines 13-17, col. 5, lines 24-25.	6,11,18
Y	US 5,455,556 A (OHM et al) 03 October 1995 (03.10.95) col. 7, lines 17-23.	1-4, 7-10, 12-16
A	US 4,002,873 A (LEWANDOWSKI) 11 January 1977 (11.01.77) entire document	1, 7, 12
A	US 4,903,002 A (SACHSSE) 20 February 1990 (20.02.90) entire document	1,7,12
A	US 5,334,967 A (PASZIEWICZ) 02 August 1994 (02.08.94) entire document	1, 7, 12

Further documents are listed in the continuation of Box C. See patent family annex.

* Special categories of cited documents:	"T" later document published after the international filing date or priority date and not in conflict with the application but cited to understand the principle or theory underlying the invention
"A" document defining the general state of the art which is not considered to be of particular relevance	"X" document of particular relevance; the claimed invention cannot be considered novel or cannot be considered to involve an inventive step when the document is taken alone
"E" earlier document published on or after the international filing date	"Y" document of particular relevance; the claimed invention cannot be considered to involve an inventive step when the document is combined with one or more other such documents, such combination being obvious to a person skilled in the art
"L" document which may throw doubts on priority claim(s) or which is cited to establish the publication date of another citation or other special reason (as specified)	"&" document member of the same patent family
"O" document referring to an oral disclosure, use, exhibition or other means	
"P" document published prior to the international filing date but later than the priority date claimed	

Date of the actual completion of the international search 30 NOVEMBER 1998	Date of mailing of the international search report 11 JAN 1999
---	--

Name and mailing address of the ISA/US Commissioner of Patents and Trademarks Box PCT Washington, D.C. 20231 Facsimile No. (703) 305-3230	Authorized officer <i>RICHARD K. LEE</i> /m <i>Sully</i> Telephone No. (703) 305-4905
---	---