



(12) **United States Patent**
Tan et al.

(10) **Patent No.:** **US 11,130,487 B2**
(45) **Date of Patent:** **Sep. 28, 2021**

(54) **METHOD FOR CONTROLLING A VEHICLE IN ACCORDANCE WITH PARAMETERS PREFERRED BY AN IDENTIFIED DRIVER**

(71) Applicant: **MAGNA ELECTRONICS INC.**, Auburn Hills, MI (US)

(72) Inventors: **Honghao Tan**, Northville, MI (US); **Brian J. Tedesco**, Novi, MI (US)

(73) Assignee: **MAGNA ELECTRONICS INC.**, Auburn Hills, MI (US)

(*) Notice: Subject to any disclaimer, the term of this patent is extended or adjusted under 35 U.S.C. 154(b) by 30 days.

(21) Appl. No.: **16/697,229**

(22) Filed: **Nov. 27, 2019**

(65) **Prior Publication Data**
US 2020/0094815 A1 Mar. 26, 2020

Related U.S. Application Data
(63) Continuation of application No. 15/959,740, filed on Apr. 23, 2018, now abandoned, which is a (Continued)

(51) **Int. Cl.**
B60W 30/14 (2006.01)
B60W 30/02 (2012.01)
(Continued)

(52) **U.S. Cl.**
CPC **B60W 30/025** (2013.01); **B60W 10/04** (2013.01); **B60W 10/18** (2013.01); **B60W 10/20** (2013.01); **B60W 30/12** (2013.01); **B60W 30/14** (2013.01); **B60W 30/16** (2013.01); **B60W 50/0098** (2013.01); **G05D 1/0088** (2013.01);
(Continued)

(58) **Field of Classification Search**
CPC G05D 1/0257; G05D 1/0055; G05D 1/024; G05D 1/0276; G05D 1/02; G05D 1/0289; G01C 21/3617; G01C 21/3697; B60W 2540/10; B60W 30/10; B60W 30/08; B60W 2530/14; B60W 2050/0095; B60W 30/12; B60W 2550/30; B60W 30/16
USPC 701/23, 52, 25, 93, 300; 455/414.2, 455/569.2
See application file for complete search history.

(56) **References Cited**
U.S. PATENT DOCUMENTS
4,829,434 A 5/1989 Karmel et al.
4,987,357 A 1/1991 Masaki
(Continued)
Primary Examiner — Dalena Tran
(74) *Attorney, Agent, or Firm* — Honigman LLP

(57) **ABSTRACT**
A method for controlling a vehicle includes providing a plurality of sensors and a control at an equipped vehicle and identifying a driver present in the vehicle and capable of operating the vehicle. When the control is not operating in a driving assist mode and the identified driver is operating the vehicle, and responsive to processing data received at the data processor, a personalized parameter set is created for the identified driver based on how the identified driver operates the equipped vehicle during determined driving conditions. When the control is operating in a driving assist mode, and responsive to a current driving condition of the vehicle, the vehicle is controlled (i) in accordance with the personalized parameter set for the identified driver present in the equipped vehicle and (ii) in accordance with data processing of data captured by at least some of the plurality of sensors.

19 Claims, 2 Drawing Sheets

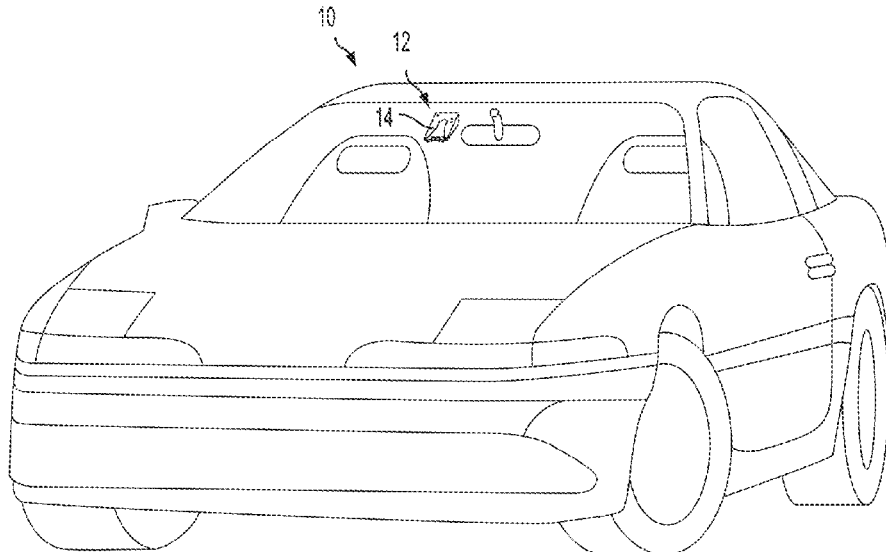

Related U.S. Application Data

continuation of application No. 15/488,715, filed on Apr. 17, 2017, now Pat. No. 9,950,707, which is a continuation of application No. 14/675,927, filed on Apr. 1, 2015, now Pat. No. 9,623,878.

(60) Provisional application No. 61/973,922, filed on Apr. 2, 2014.

(51) **Int. Cl.**

- B60W 50/00* (2006.01)
- B60W 30/12* (2020.01)
- B60W 10/04* (2006.01)
- B60W 10/18* (2012.01)
- B60W 10/20* (2006.01)
- B60W 30/16* (2020.01)
- G05D 1/00* (2006.01)
- G05D 1/02* (2020.01)

(52) **U.S. Cl.**

CPC ... *G05D 1/0231* (2013.01); *B60W 2050/0088* (2013.01); *B60W 2420/42* (2013.01); *B60W 2420/52* (2013.01); *B60W 2540/043* (2020.02); *B60W 2540/30* (2013.01); *B60W 2552/30* (2020.02); *B60W 2554/801* (2020.02); *B60W 2555/20* (2020.02); *B60W 2556/00* (2020.02); *B60W 2710/18* (2013.01); *B60W 2710/20* (2013.01); *B60W 2720/10* (2013.01); *B60W 2720/106* (2013.01)

(56) **References Cited**

U.S. PATENT DOCUMENTS

5,001,558 A 3/1991 Burley et al.
 5,003,288 A 3/1991 Wilhelm
 5,012,082 A 4/1991 Watanabe
 5,016,977 A 5/1991 Baude et al.
 5,027,001 A 6/1991 Torbert
 5,027,200 A 6/1991 Petrossian et al.
 5,059,877 A 10/1991 Teder
 5,086,253 A 2/1992 Lawler
 5,096,287 A 3/1992 Kakinami et al.
 5,097,362 A 3/1992 Lynas
 5,121,200 A 6/1992 Choi
 5,130,709 A 7/1992 Toyama et al.
 5,170,374 A 12/1992 Shimohigashi et al.
 5,172,235 A 12/1992 Wilm et al.
 5,177,685 A 1/1993 Davis et al.
 5,182,502 A 1/1993 Slotkowski et al.
 5,184,956 A 2/1993 Langlais et al.
 5,189,561 A 2/1993 Hong
 5,189,621 A 2/1993 Onari et al.
 5,193,000 A 3/1993 Lipton et al.
 5,204,778 A 4/1993 Bechtel
 5,208,701 A 5/1993 Maeda
 5,245,422 A 9/1993 Borcherts et al.
 5,276,389 A 1/1994 Levers
 5,285,060 A 2/1994 Larson et al.
 5,289,182 A 2/1994 Brillard et al.
 5,289,321 A 2/1994 Secor
 5,307,136 A 4/1994 Saneyoshi
 5,309,137 A 5/1994 Kajiwara
 5,313,072 A 5/1994 Vachss
 5,325,096 A 6/1994 Pakett
 5,325,386 A 6/1994 Jewell et al.
 5,329,206 A 7/1994 Slotkowski et al.
 5,331,312 A 7/1994 Kudoh
 5,336,980 A 8/1994 Levers
 5,341,437 A 8/1994 Nakayama
 5,351,044 A 9/1994 Mathur et al.
 5,355,118 A 10/1994 Fukuhara
 5,374,852 A 12/1994 Parkes
 5,386,285 A 1/1995 Asayama

5,394,333 A 2/1995 Kao
 5,406,395 A 4/1995 Wilson et al.
 5,410,346 A 4/1995 Saneyoshi et al.
 5,414,257 A 5/1995 Stanton
 5,414,461 A 5/1995 Kishi et al.
 5,416,313 A 5/1995 Larson et al.
 5,416,318 A 5/1995 Hegyi
 5,416,478 A 5/1995 Morinaga
 5,424,952 A 6/1995 Asayama
 5,426,294 A 6/1995 Kobayashi et al.
 5,430,431 A 7/1995 Nelson
 5,434,407 A 7/1995 Bauer et al.
 5,440,428 A 8/1995 Hegg et al.
 5,444,478 A 8/1995 Lelong et al.
 5,451,822 A 9/1995 Bechtel et al.
 5,461,357 A 10/1995 Yoshioka et al.
 5,469,298 A 11/1995 Suman et al.
 5,471,515 A 11/1995 Fossum et al.
 5,475,494 A 12/1995 Nishida et al.
 5,498,866 A 3/1996 Bendicks et al.
 5,500,766 A 3/1996 Stonecypher
 5,510,983 A 4/1996 Lino
 5,515,448 A 5/1996 Nishitani
 5,521,633 A 5/1996 Nakajima et al.
 5,528,698 A 6/1996 Kamei et al.
 5,529,138 A 6/1996 Shaw et al.
 5,530,240 A 6/1996 Larson et al.
 5,530,420 A 6/1996 Tsuchiya et al.
 5,535,314 A 7/1996 Alves et al.
 5,537,003 A 7/1996 Bechtel et al.
 5,539,397 A 7/1996 Asanuma et al.
 5,541,590 A 7/1996 Nishio
 5,550,677 A 8/1996 Schofield et al.
 5,555,555 A 9/1996 Sato et al.
 5,568,027 A 10/1996 Teder
 5,574,443 A 11/1996 Hsieh
 5,581,464 A 12/1996 Woll et al.
 5,614,788 A 3/1997 Mullins
 5,634,709 A 6/1997 Iwama
 5,642,299 A 6/1997 Hardin et al.
 5,648,835 A 7/1997 Uzawa
 5,650,944 A 7/1997 Kise
 5,660,454 A 8/1997 Mori et al.
 5,661,303 A 8/1997 Teder
 5,666,028 A 9/1997 Bechtel et al.
 5,670,935 A 9/1997 Schofield et al.
 5,677,851 A 10/1997 Kingdon et al.
 5,699,044 A 12/1997 Van Lente et al.
 5,724,316 A 3/1998 Brunts
 5,732,379 A 3/1998 Eckert et al.
 5,737,226 A 4/1998 Olson et al.
 5,760,828 A 6/1998 Cortes
 5,760,931 A 6/1998 Saburi et al.
 5,761,094 A 6/1998 Olson et al.
 5,765,116 A 6/1998 Wilson-Jones et al.
 5,765,118 A 6/1998 Fukatani
 5,781,437 A 7/1998 Wiemer et al.
 5,786,772 A 7/1998 Schofield et al.
 5,790,403 A 8/1998 Nakayama
 5,790,973 A 8/1998 Blaker et al.
 5,793,308 A 8/1998 Rosinski et al.
 5,793,420 A 8/1998 Schmidt
 5,796,094 A 8/1998 Schofield et al.
 5,837,994 A 11/1998 Stam et al.
 5,844,505 A 12/1998 Van Ryzin
 5,844,682 A 12/1998 Kiyomoto et al.
 5,845,000 A 12/1998 Breed et al.
 5,848,802 A 12/1998 Breed et al.
 5,850,176 A 12/1998 Kinoshita et al.
 5,850,254 A 12/1998 Takano et al.
 5,867,591 A 2/1999 Onda
 5,877,707 A 3/1999 Kowalick
 5,877,897 A 3/1999 Schofield et al.
 5,878,357 A 3/1999 Sivashankar et al.
 5,878,370 A 3/1999 Olson
 5,883,739 A 3/1999 Ashihara et al.
 5,884,212 A 3/1999 Lion
 5,890,021 A 3/1999 Onoda
 5,896,085 A 4/1999 Mori et al.

(56)

References Cited

U.S. PATENT DOCUMENTS

5,899,956	A	5/1999	Chan	7,123,168	B2	10/2006	Schofield
5,915,800	A	6/1999	Hiwatashi et al.	7,136,753	B2	11/2006	Samukawa et al.
5,923,027	A	7/1999	Stam et al.	7,145,519	B2	12/2006	Takahashi et al.
5,924,212	A	7/1999	Domanski	7,149,613	B2	12/2006	Stam et al.
5,949,331	A	9/1999	Schofield et al.	7,161,616	B1	1/2007	Okamoto et al.
5,959,555	A	9/1999	Furuta	7,195,381	B2	3/2007	Lynam et al.
5,963,247	A	10/1999	Banitt	7,202,776	B2	4/2007	Breed
5,990,469	A	11/1999	Bechtel et al.	7,227,611	B2	6/2007	Hull et al.
5,990,649	A	11/1999	Nagao	7,365,769	B1	4/2008	Mager
6,020,704	A	2/2000	Buschur	7,460,951	B2	12/2008	Altan
6,049,171	A	4/2000	Stam et al.	7,490,007	B2	2/2009	Taylor et al.
6,066,933	A	5/2000	Ponziana	7,526,103	B2	4/2009	Schofield et al.
6,084,519	A	7/2000	Coulling et al.	7,592,928	B2	9/2009	Chinomi et al.
6,097,024	A	8/2000	Stam et al.	7,639,149	B2	12/2009	Katoh
6,100,799	A	8/2000	Fenk	7,681,960	B2	3/2010	Wanke et al.
6,144,022	A	11/2000	Tenenbaum et al.	7,720,580	B2	5/2010	Higgins-Luthman
6,175,300	B1	1/2001	Kendrick	7,724,962	B2	5/2010	Zhu et al.
6,198,996	B1	3/2001	Berstis	7,855,755	B2	12/2010	Weller et al.
6,201,642	B1	3/2001	Bos	7,881,496	B2	2/2011	Camilleri et al.
6,223,114	B1	4/2001	Boros et al.	7,952,490	B2	5/2011	Fechner et al.
6,266,082	B1	7/2001	Yonezawa et al.	8,013,780	B2	9/2011	Lynam
6,266,442	B1	7/2001	Laumeyer et al.	8,027,029	B2	9/2011	Lu et al.
6,285,393	B1	9/2001	Shimoura et al.	8,634,980	B1	1/2014	Urmson et al.
6,294,989	B1	9/2001	Schofield et al.	8,849,495	B2	9/2014	Chundrik, Jr. et al.
6,297,781	B1	10/2001	Turnbull et al.	8,954,255	B1	2/2015	Crawford
6,310,611	B1	10/2001	Caldwell	9,014,915	B2	4/2015	Chatterjee et al.
6,317,057	B1	11/2001	Lee	9,623,878	B2	4/2017	Tan et al.
6,320,282	B1	11/2001	Caldwell	9,950,707	B2	4/2018	Tan et al.
6,333,759	B1	12/2001	Mazzilli	2002/0015153	A1	2/2002	Downs
6,353,392	B1	3/2002	Schofield et al.	2002/0113873	A1	8/2002	Williams
6,370,329	B1	4/2002	Teuchert	2003/0137586	A1	7/2003	Lewellen
6,392,315	B1	5/2002	Jones et al.	2003/0222982	A1	12/2003	Hamdan et al.
6,396,397	B1	5/2002	Bos et al.	2004/0114381	A1	6/2004	Salmeen et al.
6,411,204	B1	6/2002	Bloomfield et al.	2005/0137757	A1	6/2005	Phelan et al.
6,424,273	B1	7/2002	Gutta et al.	2006/0018511	A1	1/2006	Stam et al.
6,430,303	B1	8/2002	Naoi et al.	2006/0018512	A1	1/2006	Stam et al.
6,442,465	B2	8/2002	Breed et al.	2006/0091813	A1	5/2006	Stam et al.
6,477,464	B2	11/2002	McCarthy et al.	2006/0103727	A1	5/2006	Tseng
6,497,503	B1	12/2002	Dassanayake et al.	2006/0164221	A1	7/2006	Jensen
6,498,620	B2	12/2002	Schofield et al.	2006/0250501	A1	11/2006	Widmann et al.
6,534,884	B2	3/2003	Marcus et al.	2006/0290479	A1	12/2006	Akatsuka et al.
6,539,306	B2	3/2003	Turnbull	2007/0104476	A1	5/2007	Yasutomi et al.
6,553,130	B1	4/2003	Lemelson et al.	2009/0093938	A1	4/2009	Isaji et al.
6,594,583	B2	7/2003	Ogura et al.	2009/0113509	A1	4/2009	Tseng et al.
6,611,610	B1	8/2003	Stam et al.	2009/0177347	A1	7/2009	Breuer et al.
6,636,258	B2	10/2003	Strumolo	2009/0243824	A1	10/2009	Peterson et al.
6,672,731	B2	1/2004	Schnell et al.	2009/0244361	A1	10/2009	Gebauer et al.
6,690,268	B2	2/2004	Schofield et al.	2009/0265069	A1	10/2009	Desbrunes
6,704,621	B1	3/2004	Stein et al.	2010/0020170	A1	1/2010	Higgins-Luthman et al.
6,711,474	B1	3/2004	Treyz et al.	2010/0023223	A1	1/2010	Huang et al.
6,735,506	B2	5/2004	Breed et al.	2010/0191421	A1*	7/2010	Nilsson B62D 6/003 701/41
6,744,353	B2	6/2004	Sjonell	2010/0228437	A1	9/2010	Hanzawa et al.
6,795,221	B1	9/2004	Urey	2012/0044066	A1	2/2012	Mauderer et al.
6,806,452	B2	10/2004	Bos et al.	2012/0062743	A1	3/2012	Lynam et al.
6,819,231	B2	11/2004	Berberich et al.	2012/0218412	A1	8/2012	Dellantoni et al.
6,823,241	B2	11/2004	Shirato et al.	2012/0262340	A1	10/2012	Hassan et al.
6,824,281	B2	11/2004	Schofield et al.	2012/0277947	A1	11/2012	Boehringer et al.
6,850,156	B2	2/2005	Bloomfield et al.	2013/0124052	A1	5/2013	Hahne
6,889,161	B2	5/2005	Winner et al.	2013/0129150	A1	5/2013	Saito
6,909,753	B2	6/2005	Meehan et al.	2013/0131918	A1	5/2013	Hahne
6,946,978	B2	9/2005	Schofield	2014/0067206	A1	3/2014	Pflug
6,975,775	B2	12/2005	Rykowski et al.	2014/0156157	A1	6/2014	Johnson et al.
6,989,736	B2	1/2006	Berberich et al.	2014/0222280	A1	8/2014	Salomonsson et al.
7,004,606	B2	2/2006	Schofield	2014/0313339	A1	10/2014	Diessner
7,038,577	B2	5/2006	Pawlicki et al.	2014/0379233	A1	12/2014	Chundrik, Jr. et al.
7,062,300	B1	6/2006	Kim	2015/0112543	A1	4/2015	Binion et al.
7,065,432	B2	6/2006	Moisel et al.	2015/0166059	A1*	6/2015	Ko B60T 7/22 701/28
7,079,017	B2	7/2006	Lang et al.	2015/0203116	A1	7/2015	Fairgrieve et al.
7,085,637	B2	8/2006	Breed et al.	2017/0032673	A1*	2/2017	Scofield H04L 9/3247
7,092,548	B2	8/2006	Laumeyer et al.	2017/0305349	A1*	10/2017	Naboulsi B60R 1/025
7,111,968	B2	9/2006	Bauer et al.	2018/0237002	A1	8/2018	Tan et al.
7,116,246	B2	10/2006	Winter et al.				

* cited by examiner

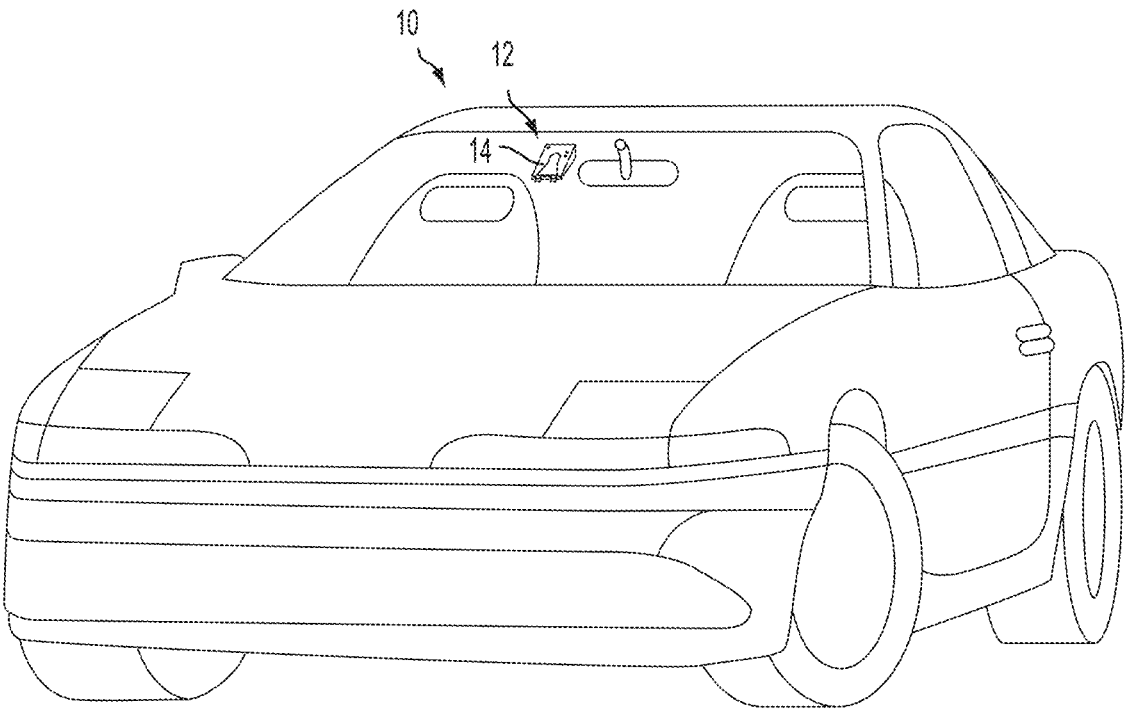

FIG. 1

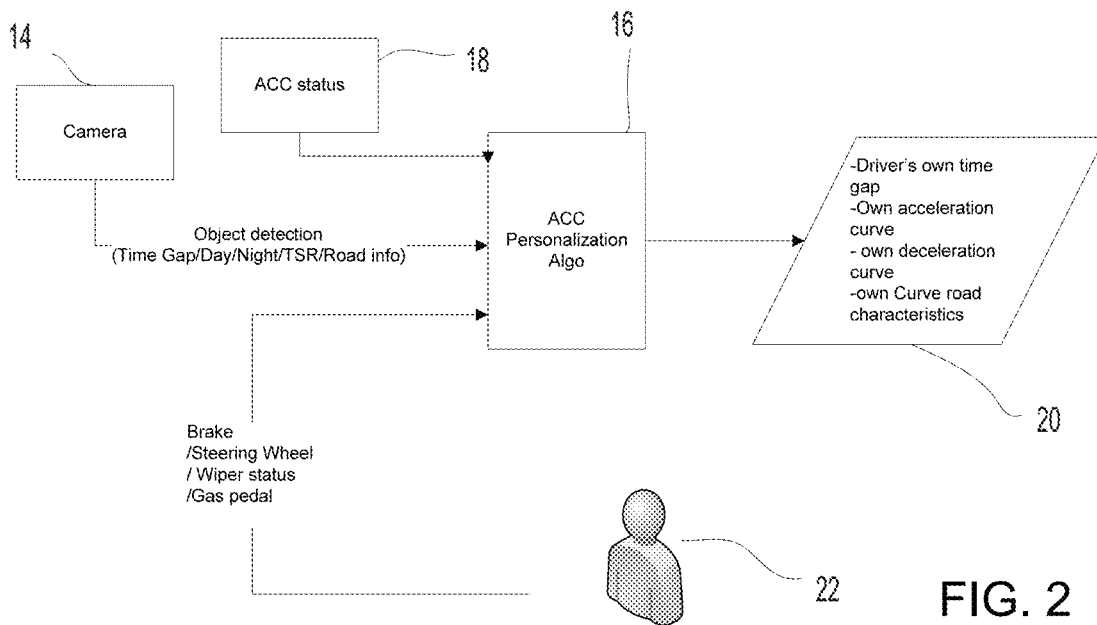

FIG. 2

Pseudo logic of ACC Learning Algo

```

If ACCOff
{
Action1 : Observe the time gap/accl/decel/cure Accel in different traffic scenarios
(following/cut in/cut out);
Action 2: confirm that those are typical repeated pattern;
Action3: adjust the time gap setting for (Near/Medium/Far) to match how driver behaves;
Action4: adjust the ACC acceleration curve to match how driver behaves;
Action5: adjust the ACC deceleration curve to match how driver behaves;
Action6: adjust ACC acceleration curve on curve road to match how driver behaves;
}
Else % ACC is ON
{
Action1: Observe the time gap/accl/decel/cure Accel
during the driver override behavior (gas/brake)
Action 2: confirm that those are typical repeated pattern;
Action3: adjust the time gap setting for (Near/Medium/Far) to match how driver behaves;
Action4: adjust the ACC acceleration curve to match how driver behaves;
Action5: adjust the ACC deceleration curve to match how driver behaves;
Action6: adjust ACC acceleration curve on curve road to match how driver behaves;
}
    
```

Note: weather condition from EQ3 should be taken into account in the time gap/accl/decl/cure accel observation)

FIG. 3

1

METHOD FOR CONTROLLING A VEHICLE IN ACCORDANCE WITH PARAMETERS PREFERRED BY AN IDENTIFIED DRIVER

CROSS REFERENCE TO RELATED APPLICATIONS

The present application is a continuation of U.S. patent application Ser. No. 15/959,740, filed Apr. 23, 2018, which is a continuation of U.S. patent application Ser. No. 15/488,715, filed Apr. 17, 2017, now U.S. Pat. No. 9,950,707, which is a continuation of U.S. patent application Ser. No. 14/675,927, filed Apr. 1, 2015, now U.S. Pat. No. 9,623,878, which claims the filing benefits of U.S. provisional application Ser. No. 61/973,922, filed Apr. 2, 2014, which is hereby incorporated herein by reference in its entirety.

TECHNICAL FIELD OF THE INVENTION

The present invention generally relates to driver assistance systems, and more particularly to personalized autonomous driving systems which learn driver habits.

BACKGROUND OF THE INVENTION

Use of imaging sensors in vehicle imaging systems is common and known. Examples of such known systems are described in U.S. Pat. Nos. 5,949,331; 5,670,935 and/or 5,550,677, which are hereby incorporated herein by reference in their entireties.

SUMMARY OF THE INVENTION

The present invention provides a driver assistance system that includes a personalization algorithm or system or process that learns the preferences or driving behavior of a particular driver and adapts or adjusts or modifies parameters of the driver assistance system so that the driver assistance system controls the vehicle in a manner similar to the manner that the particular driver controls the vehicles in similar driving conditions. The system is responsive to a determination or identification of a particular driver and to a determination of the road and/or driving conditions. Thus, when the driver assistance system (such as an adaptive cruise control system or the like) is activated, the system may control the acceleration/deceleration/steering of the vehicle in a manner that is preferred by the particular driver.

These and other objects, advantages, purposes and features of the present invention will become apparent upon review of the following specification in conjunction with the drawings.

BRIEF DESCRIPTION OF THE DRAWINGS

FIG. 1 is a perspective view of a vehicle equipped with a driver assistance system of the present invention;

FIG. 2 shows an exemplary personalized autonomous cruise control system in accordance with the present invention; and

FIG. 3 is a pseudo code listing showing an exemplary personalization algorithm for an autonomous cruise control system.

DETAILED DESCRIPTION OF THE PREFERRED EMBODIMENTS

A vehicle driver assist system and/or vision system and/or object detection system and/or alert system may utilize one

2

or more sensors at the vehicle, such as one or more cameras that operate to capture images exterior of the vehicle, whereby an image processor may process the captured image data such as for displaying images and/or for detecting objects or the like at or near the vehicle and in the predicted path of the vehicle, such as to assist a driver of the vehicle in maneuvering the vehicle in a forward and/or rearward direction.

Referring now to the drawings and the illustrative embodiments depicted therein, a vehicle **10** includes a driver assistance system **12** that may include at least one exterior facing imaging sensor or camera, such as a forward facing camera **14** (optionally, the system may include a rearward facing imaging sensor or camera and may optionally include multiple exterior facing imaging sensors or cameras, such as a forwardly facing camera at the front (or at the windshield) of the vehicle, and a sidewardly/rearwardly facing camera at respective sides of the vehicle, which capture images exterior of the vehicle (FIG. 1). The camera has a lens for focusing images at or onto an imaging array or imaging plane or imager of the camera. The driver assistance system includes a control or electronic control unit (ECU) or processor that is operable to process image data captured by the cameras (or to process other data captured by other sensors of the vehicle) and may provide displayed images at a display device for viewing by the driver of the vehicle. The data transfer or signal communication from the camera to the ECU may comprise any suitable data or communication link, such as a vehicle network bus or the like of the equipped vehicle.

Autonomous or Adaptive Cruise Control (ACC) Systems are known to control the longitudinal distance between a host vehicle and a target vehicle. Such systems comprise sensors and control algorithms to control acceleration or deceleration of the host vehicle. Suitable sensors to detect a preceding vehicle are for example a radar sensor, a lidar sensor, a monocular camera or a stereo camera.

Lane Keep Assist (LKA) Systems are known to control the lateral position of a host vehicle as it approaches a lane marking. Such systems comprise sensors and control algorithms to applying torque to the steering system. Suitable sensors to detect lane markings are a monocular camera or a stereo camera.

Lane Centering (LC) Systems are known to control the lateral position of a host vehicle within a lane. Such systems comprise sensors and control algorithms to applying torque to the steering system. Suitable sensors to detect lane markings are a monocular camera or a stereo camera.

Existing systems may provide limited ability to adjust to a driver's preference. For example, an autonomous cruise control system may offer a "near", "mid" and "far" setting to adjust a following target distance. However, such adjustments are limited, and do not reflect the wide range of individual driving preferences by human drivers.

Referring to FIGS. 2 and 3, an exemplary personalized autonomous cruise control system is shown. A personalization algorithm **16** is provided within a suitable embedded control module. Preferably, the personalization algorithm **16** is embedded in the same module as the autonomous cruise control algorithms. The personalization algorithm **16** receives various inputs. Firstly, the personalization algorithm **16** is in communication with the autonomous or adaptive cruise control (ACC) system **18**. From the autonomous cruise control system **18**, the personalization algorithm **16** receives information about whether the autonomous cruise control system is enabled or disabled (in other words, whether acceleration of the vehicle is controlled by

the driver or by the ACC system 18). If ACC is active, the information from the ACC system 18 further comprises the currently requested acceleration. The term “acceleration” is here used to refer to both positive and negative acceleration (in other words, it includes deceleration).

The personalization algorithm 16 is further in communication with environment sensors, such as a machine vision camera 14 (such as the forward facing camera 14 in FIG. 1). The machine vision camera 14 is adapted to sense and communicate information about the surrounding of the host vehicle. Such information includes, for example, the distance and relative velocity to a preceding vehicle (ahead of the subject or equipped vehicle). Optionally, such information may include information about whether it is daytime, twilight, or nighttime or whether it is dry or raining or snowing or the like. The information may further include information about traffic signs that have been passed, and may indicate a speed limit that may apply. The information may also include information about road surface characteristics, such as whether the road surface is smooth or bumpy, possibly estimating a friction coefficient of the road. The information may further comprise information about lane geometry. Lane geometry may be communicated in the form of a polynomial representation of the lanes ahead of the host vehicle, and can be used to determine, for example, the width of the lane the host vehicle is travelling in, or the curvature of the road ahead of the vehicle.

The personalization algorithm 16 is further in communication with vehicle sensors that communicate the present state of the vehicle, which is ultimately determined by a driver 22. Such sensors may include, for example, accelerator pedal position and brake pedal position. They may include a steering angle sensor or steering wheel angle sensor. They may further include information identifying the driver, such as, for example, by determining which seat position has been selected in a memory seat module or the like. Information may also include wiper status or outside temperature.

The personalization algorithm 16 processes data received via various inputs to create a personalized parameter set 20 for the adaptive cruise control system. The personalized parameter set 20 comprises parameters that determine the ACC system’s response to particular driving scenarios. The personalized parameter set 20 may comprise, for example, a following gap parameter that determines at what time gap the host vehicle follows a preceding vehicle. Traditionally, ACC systems allow adjustment of the following gap in predetermined steps, such as, for example, a “near” setting, a “mid” setting and a “far” setting. Here, the following gap parameter is more flexible, allowing, for example, a following gap preference to be adjustable between a lower threshold of about 0.7 seconds or thereabouts and an upper threshold of about three seconds or thereabouts.

The personalized parameter set 20 may also comprise parameters that determine how rapidly the host vehicle accelerates if a preceding vehicle changes lanes and is no longer relevant, or how aggressively the host vehicle decelerated after a cut-in of another vehicle into the host vehicle’s lane. The personalized parameter set may also comprise parameters that determine how an ACC target speed is adjusted depending on the radius of an upcoming curve.

Traditionally, adjusting ACC parameters is done by calibration engineers, who tune a “one size fits all” parameter set for a given vehicle. The present invention may utilize such a default setting, but allows for personalized changes to the personalized parameter set as the personalization algorithm 16 learns the behavior of the driver 22. This learning

may occur while the driver is driving manually (in other words, not using ACC). During manual driving, the personalization algorithm 16 will observe or monitor the driver’s behavior in predetermined driving situations. For example, the personalization algorithm may calculate an average time gap at which the driver 22 is following a preceding vehicle while driving on a wide road during daytime in the rain. This average may be stored in the parameter set 20 and used when using the ACC system is used in similar driving conditions.

Learning may also occur while the ACC system is active, such as when the driver is overriding the ACC system’s acceleration. For example, the driver may manually accelerate more aggressively, after a preceding vehicle has left the host vehicle lane. In that case, that personalization algorithm 16 may, over time, adjust the corresponding parameter in the parameter set 20, to allow the ACC system to use more aggressive acceleration in similar situations.

Optionally, the system may provide personalization or customization of parameters of a lane keep assist system or lane departure warning system or lane centering system or the like. The personalization algorithm may allow the driver to establish preferences as to how the vehicle travels in and along a lane and/or how the system provides or generates an alert when the vehicle moves towards an edge or lane marker of the travelled lane or the like. For example, the system may, responsive to identification of a particular driver and that driver’s preferences, adjust the threshold level at which an alert is generated as the vehicle moves towards a lane marker or out of a lane in which the vehicle is traveling or adjust the threshold level at which a steering adjustment is made as the vehicle moves towards a lane marker or out of a lane in which the vehicle is traveling.

Therefore, the present invention provides a customizable or personalized driver assistance system, such as a customizable or personalized adaptive cruise control system. The system monitors a particular driver’s driving behavior in various driving conditions and stores to memory different driving maneuvers that the driver typically undertakes in particular driving conditions (such as rapid acceleration when a preceding vehicle leaves the subject vehicle’s lane when the road is substantially dry). The system stores various driver behaviors under various driving conditions, road conditions, weather conditions and/or the like, so that when the driver uses the ACC system of the vehicle, the ACC system tends to accelerate/decelerate/drive the vehicle like that particular driver (and not necessarily like the default ACC system settings). Thus, responsive to the system identifying the particular driver (such as via a user input or selection or image processing of image data captured by a cabin monitoring cabin to recognize the driver’s face or the like), the system may adjust the ACC parameters (and/or parameters of other driver assistance system or systems of the vehicle) to control the various driver assistance systems or accessories to the driver’s preference. For example, the system may adjust the control of the vehicle brakes, steering and/or accelerator (such as when the ACC system is activated) and/or may adjust an intermittent windshield wiper setting or the like to generally match the driver’s preferences as learned by the system.

The system may be at least responsive to weather conditions and/or road conditions so that the adjusted parameters are appropriate for the particular driver and for the particular driving conditions being experienced by the driver and vehicle. The system may include limits that limit how far the system may adjust the parameters to maintain safety during use of the ACC system. For example, if the driver tends to follow very closely behind preceding vehicles, the system

will not adjust the ACC system to follow the preceding vehicle at an unsafe distance.

The system may use one or more cameras to monitor the road and/or weather conditions and/or the like. The camera or sensor may comprise any suitable camera or sensor. Optionally, the camera may comprise a “smart camera” that includes the imaging sensor array and associated circuitry and image processing circuitry and electrical connectors and the like as part of a camera module, such as by utilizing aspects of the vision systems described in International Publication Nos. WO 2013/081984 and/or WO 2013/081985, which are hereby incorporated herein by reference in their entireties.

The system includes an image processor operable to process image data captured by the camera or cameras, such as for detecting objects or other vehicles or pedestrians or the like in the field of view of one or more of the cameras. For example, the image processor may comprise an EYEQ2 or EYEQ3 image processing chip available from Mobileye Vision Technologies Ltd. of Jerusalem, Israel, and may include object detection software (such as the types described in U.S. Pat. Nos. 7,855,755; 7,720,580 and/or 7,038,577, which are hereby incorporated herein by reference in their entireties), and may analyze image data to detect vehicles and/or other objects. Responsive to such image processing, and when an object or other vehicle is detected, the system may generate an alert to the driver of the vehicle and/or may generate an overlay at the displayed image to highlight or enhance display of the detected object or vehicle, in order to enhance the driver’s awareness of the detected object or vehicle or hazardous condition during a driving maneuver of the equipped vehicle.

The vehicle may include any type of sensor or sensors, such as imaging sensors or radar sensors or lidar sensors or ladar sensors or ultrasonic sensors or the like. The imaging sensor or camera may capture image data for image processing and may comprise any suitable camera or sensing device, such as, for example, a two dimensional array of a plurality of photosensor elements arranged in at least 640 columns and 480 rows (at least a 640x480 imaging array, such as a megapixel imaging array or the like), with a respective lens focusing images onto respective portions of the array. The photosensor array may comprise a plurality of photosensor elements arranged in a photosensor array having rows and columns. Preferably, the imaging array has at least 300,000 photosensor elements or pixels, more preferably at least 500,000 photosensor elements or pixels and more preferably at least 1 million photosensor elements or pixels. The imaging array may capture color image data, such as via spectral filtering at the array, such as via an RGB (red, green and blue) filter or via a red/red complement filter or such as via an RCC (red, clear, clear) filter or the like. The logic and control circuit of the imaging sensor may function in any known manner, and the image processing and algorithmic processing may comprise any suitable means for processing the images and/or image data.

For example, the vision system and/or processing and/or camera and/or circuitry may utilize aspects described in U.S. Pat. Nos. 7,005,974; 5,760,962; 5,877,897; 5,796,094; 5,949,331; 6,222,447; 6,302,545; 6,396,397; 6,498,620; 6,523,964; 6,611,202; 6,201,642; 6,690,268; 6,717,610; 6,757,109; 6,802,617; 6,806,452; 6,822,563; 6,891,563; 6,946,978; 7,859,565; 5,550,677; 5,670,935; 6,636,258; 7,145,519; 7,161,616; 7,230,640; 7,248,283; 7,295,229; 7,301,466; 7,592,928; 7,881,496; 7,720,580; 7,038,577; 6,882,287; 5,929,786 and/or 5,786,772, and/or International Publication Nos. WO 2011/028686; WO 2010/099416; WO

2012/061567; WO 2012/068331; WO 2012/075250; WO 2012/103193; WO 2012/0116043; WO 2012/0145313; WO 2012/0145501; WO 2012/145818; WO 2012/145822; WO 2012/158167; WO 2012/075250; WO 2012/0116043; WO 2012/0145501; WO 2012/154919; WO 2013/019707; WO 2013/016409; WO 2013/019795; WO 2013/067083; WO 2013/070539; WO 2013/043661; WO 2013/048994; WO 2013/063014, WO 2013/081984; WO 2013/081985; WO 2013/074604; WO 2013/086249; WO 2013/103548; WO 2013/109869; WO 2013/123161; WO 2013/126715; WO 2013/043661 and/or WO 2013/158592, which are all hereby incorporated herein by reference in their entireties. The system may communicate with other communication systems via any suitable means, such as by utilizing aspects of the systems described in International Publication Nos. WO 2010/144900; WO 2013/043661 and/or WO 2013/081985, and/or U.S. Publication No. US-2012-0062743, which are hereby incorporated herein by reference in their entireties.

The imaging device and control and image processor and any associated illumination source, if applicable, may comprise any suitable components, and may utilize aspects of the cameras and vision systems described in U.S. Pat. Nos. 5,550,677; 5,877,897; 6,498,620; 5,670,935; 5,796,094; 6,396,397; 6,806,452; 6,690,268; 7,005,974; 7,937,667; 7,123,168; 7,004,606; 6,946,978; 7,038,577; 6,353,392; 6,320,176; 6,313,454 and/or 6,824,281, and/or International Publication Nos. WO 2010/099416; WO 2011/028686 and/or WO 2013/016409, and/or U.S. Pat. Publication No. US 2010-0020170, which are all hereby incorporated herein by reference in their entireties. The camera or cameras may comprise any suitable cameras or imaging sensors or camera modules, and may utilize aspects of the cameras or sensors described in U.S. Publication No. US-2009-0244361 and/or U.S. Pat. Nos. 8,542,451; 7,965,336 and/or 7,480,149, which are hereby incorporated herein by reference in their entireties. The imaging array sensor may comprise any suitable sensor, and may utilize various imaging sensors or imaging array sensors or cameras or the like, such as a CMOS imaging array sensor, a CCD sensor or other sensors or the like, such as the types described in U.S. Pat. Nos. 5,550,677; 5,670,935; 5,760,962; 5,715,093; 5,877,897; 6,922,292; 6,757,109; 6,717,610; 6,590,719; 6,201,642; 6,498,620; 5,796,094; 6,097,023; 6,320,176; 6,559,435; 6,831,261; 6,806,452; 6,396,397; 6,822,563; 6,946,978; 7,339,149; 7,038,577; 7,004,606; 7,720,580 and/or 7,965,336, and/or International Publication Nos. WO 2009/036176 and/or WO 2009/046268, which are all hereby incorporated herein by reference in their entireties.

The camera module and circuit chip or board and imaging sensor may be implemented and operated in connection with various vehicular vision-based systems, and/or may be operable utilizing the principles of such other vehicular systems, such as a vehicle headlamp control system, such as the type disclosed in U.S. Pat. Nos. 5,796,094; 6,097,023; 6,320,176; 6,559,435; 6,831,261; 7,004,606; 7,339,149 and/or 7,526,103, which are all hereby incorporated herein by reference in their entireties, a rain sensor, such as the types disclosed in commonly assigned U.S. Pat. Nos. 6,353,392; 6,313,454; 6,320,176 and/or 7,480,149, which are hereby incorporated herein by reference in their entireties, a vehicle vision system, such as a forwardly, sidewardly or rearwardly directed vehicle vision system utilizing principles disclosed in U.S. Pat. Nos. 5,550,677; 5,670,935; 5,760,962; 5,877,897; 5,949,331; 6,222,447; 6,302,545; 6,396,397; 6,498,620; 6,523,964; 6,611,202; 6,201,642; 6,690,268; 6,717,610; 6,757,109; 6,802,617; 6,806,452; 6,822,563; 6,891,563; 6,946,978 and/or 7,859,565, which are all hereby

incorporated herein by reference in their entireties, a trailer hitching aid or tow check system, such as the type disclosed in U.S. Pat. No. 7,005,974, which is hereby incorporated herein by reference in its entirety, a reverse or sideward imaging system, such as for a lane change assistance system or lane departure warning system or for a blind spot or object detection system, such as imaging or detection systems of the types disclosed in U.S. Pat. Nos. 7,881,496; 7,720,580; 7,038,577; 5,929,786 and/or 5,786,772, which are hereby incorporated herein by reference in their entireties, a video device for internal cabin surveillance and/or video telephone function, such as disclosed in U.S. Pat. Nos. 5,760,962; 5,877,897; 6,690,268 and/or 7,370,983, and/or U.S. Publication No. US-2006-0050018, which are hereby incorporated herein by reference in their entireties, a traffic sign recognition system, a system for determining a distance to a leading or trailing vehicle or object, such as a system utilizing the principles disclosed in U.S. Pat. Nos. 6,396,397 and/or 7,123,168, which are hereby incorporated herein by reference in their entireties, and/or the like.

Optionally, the circuit board or chip may include circuitry for the imaging array sensor and or other electronic accessories or features, such as by utilizing compass-on-a-chip or EC driver-on-a-chip technology and aspects such as described in U.S. Pat. Nos. 7,255,451 and/or 7,480,149, and/or U.S. Publication Nos. US-2006-0061008 and/or US-2010-0097469, which are hereby incorporated herein by reference in their entireties.

Optionally, the vision system may include a display for displaying images captured by one or more of the imaging sensors for viewing by the driver of the vehicle while the driver is normally operating the vehicle. Optionally, for example, the vision system may include a video display device disposed at or in the interior rearview mirror assembly of the vehicle, such as by utilizing aspects of the video mirror display systems described in U.S. Pat. No. 6,690,268 and/or U.S. Publication No. US-2012-0162427, which are hereby incorporated herein by reference in their entireties. The video mirror display may comprise any suitable devices and systems and optionally may utilize aspects of the compass display systems described in U.S. Pat. Nos. 7,370,983; 7,329,013; 7,308,341; 7,289,037; 7,249,860; 7,004,593; 4,546,551; 5,699,044; 4,953,305; 5,576,687; 5,632,092; 5,677,851; 5,708,410; 5,737,226; 5,802,727; 5,878,370; 6,087,953; 6,173,508; 6,222,460; 6,513,252 and/or 6,642,851, and/or European patent application, published Oct. 11, 2000 under Publication No. EP 0 1043566, and/or U.S. Publication No. US-2006-0061008, which are all hereby incorporated herein by reference in their entireties. Optionally, the video mirror display screen or device may be operable to display images captured by a rearward viewing camera of the vehicle during a reversing maneuver of the vehicle (such as responsive to the vehicle gear actuator being placed in a reverse gear position or the like) to assist the driver in backing up the vehicle, and optionally may be operable to display the compass heading or directional heading character or icon when the vehicle is not undertaking a reversing maneuver, such as when the vehicle is being driven in a forward direction along a road (such as by utilizing aspects of the display system described in International Publication No. WO 2012/051500, which is hereby incorporated herein by reference in its entirety).

Optionally, the vision system (utilizing the forward facing camera and a rearward facing camera and other cameras disposed at the vehicle with exterior fields of view) may be part of or may provide a display of a top-down view or birds-eye view system of the vehicle or a surround view at

the vehicle, such as by utilizing aspects of the vision systems described in International Publication Nos. WO 2010/099416; WO 2011/028686; WO 2012/075250; WO 2013/019795; WO 2012/075250; WO 2012/145822; WO 2013/081985; WO 2013/086249 and/or WO 2013/109869, and/or U.S. Publication No. US-2012-0162427, which are hereby incorporated herein by reference in their entireties.

Optionally, a video mirror display may be disposed rearward of and behind the reflective element assembly and may comprise a display such as the types disclosed in U.S. Pat. Nos. 5,530,240; 6,329,925; 7,855,755; 7,626,749; 7,581,859; 7,446,650; 7,370,983; 7,338,177; 7,274,501; 7,255,451; 7,195,381; 7,184,190; 5,668,663; 5,724,187 and/or 6,690,268, and/or in U.S. Publication Nos. US-2006-0061008 and/or US-2006-0050018, which are all hereby incorporated herein by reference in their entireties. The display is viewable through the reflective element when the display is activated to display information. The display element may be any type of display element, such as a vacuum fluorescent (VF) display element, a light emitting diode (LED) display element, such as an organic light emitting diode (OLED) or an inorganic light emitting diode, an electroluminescent (EL) display element, a liquid crystal display (LCD) element, a video screen display element or backlit thin film transistor (TFT) display element or the like, and may be operable to display various information (as discrete characters, icons or the like, or in a multi-pixel manner) to the driver of the vehicle, such as passenger side inflatable restraint (PSIR) information, tire pressure status, and/or the like. The mirror assembly and/or display may utilize aspects described in U.S. Pat. Nos. 7,184,190; 7,255,451; 7,446,924 and/or 7,338,177, which are all hereby incorporated herein by reference in their entireties. The thicknesses and materials of the coatings on the substrates of the reflective element may be selected to provide a desired color or tint to the mirror reflective element, such as a blue colored reflector, such as is known in the art and such as described in U.S. Pat. Nos. 5,910,854; 6,420,036 and/or 7,274,501, which are hereby incorporated herein by reference in their entireties.

Optionally, the display or displays and any associated user inputs may be associated with various accessories or systems, such as, for example, a tire pressure monitoring system or a passenger air bag status or a garage door opening system or a telematics system or any other accessory or system of the mirror assembly or of the vehicle or of an accessory module or console of the vehicle, such as an accessory module or console of the types described in U.S. Pat. Nos. 7,289,037; 6,877,888; 6,824,281; 6,690,268; 6,672,744; 6,386,742 and/or 6,124,886, and/or U.S. Publication No. US-2006-0050018, which are hereby incorporated herein by reference in their entireties.

Changes and modifications in the specifically described embodiments can be carried out without departing from the principles of the invention, which is intended to be limited only by the scope of the appended claims, as interpreted according to the principles of patent law including the doctrine of equivalents.

The invention claimed is:

1. A method for controlling a vehicle, said method comprising:

- providing a forward viewing camera at an in-cabin side of a windshield of the equipped vehicle, the forward viewing camera configured to view forward through the windshield in the direction of forward travel of the equipped vehicle;
- providing a control at the equipped vehicle;

wherein the control comprises electronic circuitry, wherein the electronic circuitry comprises an image processor,

wherein the control, when operating in a driving assist mode, controls driving of the equipped vehicle by controlling (i) acceleration of the equipped vehicle, (ii) braking of the equipped vehicle and (iii) steering of the equipped vehicle;

wherein, when the control is not operating in the driving assist mode, a driver present in the equipped vehicle controls driving of the equipped vehicle by operating (i) an accelerator of the equipped vehicle, (ii) a brake system of the equipped vehicle and (iii) steering of the equipped vehicle;

capturing, via the forward viewing camera, image data; processing, via the image processor, image data captured by the forward viewing camera;

determining, at least in part via processing by the image processor of image data captured by the forward viewing camera, width of a lane of a road along which the equipped vehicle is traveling;

determining, at least in part via processing by the image processor of image data captured by the forward viewing camera, road curvature of the road along which the equipped vehicle is traveling;

identifying to the control the driver present in the equipped vehicle and capable of operating the equipped vehicle;

when the control is not operating in the driving assist mode and the identified driver is operating the equipped vehicle, determining driving conditions while the equipped vehicle is driven by the identified driver;

when the control is not operating in the driving assist mode and the identified driver is operating the equipped vehicle, providing to the control information pertaining to operation by the identified driver of the equipped vehicle while the equipped vehicle is driven by the identified driver, and wherein the provided information pertains at least to (i) acceleration of the equipped vehicle by the identified driver, (ii) braking of the equipped vehicle by the identified driver and (iii) steering of the equipped vehicle by the identified driver;

when the control is not operating in the driving assist mode and the identified driver is operating the equipped vehicle, and responsive at least in part to processing by the image processor of image data captured by the forward viewing camera, creating a personalized parameter set for the identified driver present in the equipped vehicle based on how the identified driver controls driving of the equipped vehicle during the determined driving conditions;

wherein the created personalized parameter set for the identified driver present in the equipped vehicle comprises how the equipped vehicle accelerates, brakes and steers the equipped vehicle while the equipped vehicle is driven by the identified driver during the determined driving conditions;

when the control is operating in the driving assist mode and the identified driver present in the equipped vehicle is not operating the equipped vehicle, and responsive to a current driving condition of the equipped vehicle, controlling the equipped vehicle (i) in accordance with the personalized parameter set for the identified driver present in the equipped vehicle and (ii) at least in part

in accordance with image processing by the image processor of image data captured by the forward viewing camera;

wherein, when the control is operating in the driving assist mode, the control allows temporary overriding of the driving assist mode, without disabling the driving assist mode, by takeover of driving control of the vehicle by the driver;

responsive at least in part to the driver temporarily overriding the driving assist mode while the control is still operating in the driving assist mode, updating the personalized parameter set for the identified driver present in the equipped vehicle, and wherein the update of the personalized parameter set is based at least in part on action of the driver when the driver is temporarily overriding the driving assist mode while the control is operating in the driving assist mode;

when the control is not operating in the driving assist mode, generating a lane departure alert responsive to determination that the vehicle is moving toward a lane marker on the road along which the equipped vehicle is traveling; and

adjusting a threshold level at which the lane departure alert is generated as the vehicle moves towards the lane marker or out of the lane in which the vehicle is traveling in accordance with the personalized parameter set for the identified driver present in the equipped vehicle.

2. The method of claim 1, wherein temporarily overriding the driving assist mode comprises the driver manually accelerating.

3. The method of claim 1, wherein identifying the driver is based at least in part on a seat position of the driver seat when the driver is seated in the driver seat and has selected the seat position stored in a memory seat module of the equipped vehicle.

4. The method of claim 1, wherein, when the control is operating in the driving assist mode and the identified driver present in the equipped vehicle is not operating the equipped vehicle, controlling the equipped vehicle comprises controlling the equipped vehicle in accordance with information that has been provided to the control pertaining to operation by the identified driver of the equipped vehicle while the equipped vehicle was driven by the identified driver.

5. The method of claim 1, wherein creating the personalized parameter set for the identified driver present in the equipped vehicle comprises creating the personalized parameter set for the identified driver present in the equipped vehicle by learning, while the identified driver is driving the equipped vehicle, at least one parameter indicative of the identified driver's preference for operation of or use of at least one accessory or system of the equipped vehicle.

6. The method of claim 1, comprising, while the identified driver is driving the equipped vehicle, learning at least one parameter of the personalized parameter set in accordance with information that has been provided to the control pertaining to operation by the identified driver of the equipped vehicle while the equipped vehicle was driven by the identified driver.

7. The method of claim 1, wherein the control, when operating in the driving assist mode, provides at least one of (i) adaptive cruise control for the equipped vehicle, (ii) lane keep assist for the equipped vehicle and (iii) lane centering for the equipped vehicle.

8. The method of claim 1, wherein the created personalized parameter set for the identified driver present in the

11

equipped vehicle comprises at least one parameter selected from the group consisting of (i) how rapidly the equipped vehicle, when driven by the identified driver, accelerates if a preceding vehicle changes lane and is no longer in the lane along which the equipped vehicle is traveling, (ii) how aggressively the equipped vehicle, when driven by the identified driver, decelerates after a cut-in by another vehicle into the lane along which the equipped vehicle is traveling, and (iii) how the speed of the equipped vehicle, when driven by the identified driver, is adjusted responsive to approach of the equipped vehicle to road curves ahead of the equipped vehicle.

9. A method for controlling a vehicle, said method comprising:

providing a forward viewing camera at an in-cabin side of a windshield of the equipped vehicle, the forward viewing camera configured to view forward through the windshield in the direction of forward travel of the equipped vehicle;

providing a control at the equipped vehicle; wherein the control comprises electronic circuitry, wherein the electronic circuitry comprises an image processor,

wherein the control, when operating in a driving assist mode, controls driving of the equipped vehicle by controlling (i) acceleration of the equipped vehicle, (ii) braking of the equipped vehicle and (iii) steering of the equipped vehicle;

wherein, when the control is not operating in the driving assist mode, a driver present in the equipped vehicle controls driving of the equipped vehicle by operating (i) an accelerator of the equipped vehicle, (ii) a brake system of the equipped vehicle and (iii) steering of the equipped vehicle;

capturing, via the forward viewing camera, image data; processing, via the image processor, image data captured by the forward viewing camera;

determining, at least in part via processing by the image processor of image data captured by the forward viewing camera, width of a lane of a road along which the equipped vehicle is traveling;

determining, at least in part via processing by the image processor of image data captured by the forward viewing camera, road curvature of the road along which the equipped vehicle is traveling;

identifying to the control the driver present in the equipped vehicle and capable of operating the equipped vehicle;

when the control is not operating in the driving assist mode and the identified driver is operating the equipped vehicle, determining driving conditions while the equipped vehicle is driven by the identified driver;

when the control is not operating in the driving assist mode and the identified driver is operating the equipped vehicle, providing to the control information pertaining to operation by the identified driver of the equipped vehicle while the equipped vehicle is driven by the identified driver, and wherein the provided information pertains at least to (i) acceleration of the equipped vehicle by the identified driver, (ii) braking of the equipped vehicle by the identified driver and (iii) steering of the equipped vehicle by the identified driver;

when the control is not operating in the driving assist mode and the identified driver is operating the equipped vehicle, and responsive at least in part to processing by the image processor of image data captured by the

12

forward viewing camera, creating a personalized parameter set for the identified driver present in the equipped vehicle based on how the identified driver controls driving of the equipped vehicle during the determined driving conditions;

wherein the created personalized parameter set for the identified driver present in the equipped vehicle comprises how the equipped vehicle accelerates, brakes and steers the equipped vehicle while the equipped vehicle is driven by the identified driver during the determined driving conditions;

when the control is operating in the driving assist mode and the identified driver present in the equipped vehicle is not operating the equipped vehicle, and responsive to a current driving condition of the equipped vehicle, controlling the equipped vehicle (i) in accordance with the personalized parameter set for the identified driver present in the equipped vehicle and (ii) at least in part in accordance with image processing by the image processor of image data captured by the forward viewing camera;

wherein, when the control is operating in the driving assist mode, updating the personalized parameter set for the identified driver present in the equipped vehicle based at least in part on action of the driver while the control is operating in the driving assist mode;

wherein, when the control is not operating in the driving assist mode, generating a lane departure alert responsive to determination that the vehicle is moving toward a lane marker of the lane of the road along which the equipped vehicle is traveling; and

adjusting a threshold level at which the lane departure alert is generated as the vehicle, when the control is not operating in the driving assist mode, moves towards the lane marker or out of the lane in which the vehicle is traveling in accordance with the personalized parameter set for the identified driver present in the equipped vehicle.

10. The method of claim 9, wherein, when the control is operating in the driving assist mode, the control allows temporary overriding of the driving assist mode without disabling the driving assist mode by the driver of the vehicle, and wherein, responsive at least in part to the driver temporarily overriding the driving assist mode while the control is still operating in the driving assist mode, the control updates the personalized parameter set for the identified driver present in the equipped vehicle, and wherein the update of the personalized parameter set is based on action of the driver when the driver is temporarily overriding the driving assist mode without disabling the driving assist mode.

11. The method of claim 9, wherein, when the control is operating in the driving assist mode and the identified driver present in the equipped vehicle is not operating the equipped vehicle, the control controls the equipped vehicle in accordance with information that has been provided to the control pertaining to operation by the identified driver of the equipped vehicle while the equipped vehicle was driven by the identified driver.

12. The method of claim 9, wherein creating the personalized parameter set for the identified driver present in the equipped vehicle comprises creating the personalized parameter set for the identified driver present in the equipped vehicle by learning, while the identified driver is driving the equipped vehicle, at least one parameter indica-

13

tive of the identified driver's preference for operation of or use of at least one accessory or system of the equipped vehicle.

13. The method of claim 9, comprising, while the identified driver is driving the equipped vehicle, learning at least one parameter of the personalized parameter set in accordance with information that has been provided to the control pertaining to operation by the identified driver of the equipped vehicle while the equipped vehicle was driven by the identified driver.

14. The method of claim 9, wherein the control, when operating in the driving assist mode, provides at least one of (i) adaptive cruise control for the equipped vehicle, (ii) lane keep assist for the equipped vehicle and (iii) lane centering for the equipped vehicle.

15. The method of claim 9, wherein the created personalized parameter set for the identified driver present in the equipped vehicle comprises at least one parameter selected from the group consisting of (i) how rapidly the equipped vehicle, when driven by the identified driver, accelerates if a preceding vehicle changes lane and is no longer in the lane along which the equipped vehicle is traveling, (ii) how aggressively the equipped vehicle, when driven by the identified driver, decelerates after a cut-in by another vehicle into the lane along which the equipped vehicle is traveling, and (iii) how the speed of the equipped vehicle, when driven by the identified driver, is adjusted responsive to approach of the equipped vehicle to road curves ahead of the equipped vehicle.

16. A method for controlling a vehicle, said method comprising:

providing a forward viewing camera at an in-cabin side of a windshield of the equipped vehicle, the forward viewing camera configured to view forward through the windshield in the direction of forward travel of the equipped vehicle;

providing a control at the equipped vehicle; wherein the control comprises electronic circuitry, wherein the electronic circuitry comprises an image processor;

wherein the control, when operating in a driving assist mode, controls driving of the equipped vehicle by controlling (i) acceleration of the equipped vehicle, (ii) braking of the equipped vehicle and (iii) steering of the equipped vehicle;

wherein, when the control is not operating in the driving assist mode, a driver present in the equipped vehicle controls driving of the equipped vehicle by operating (i) an accelerator of the equipped vehicle, (ii) a brake system of the equipped vehicle and (iii) steering of the equipped vehicle;

capturing, via the forward viewing camera, image data; processing, via the image processor, image data captured by the forward viewing camera;

determining, at least in part via processing by the image processor of image data captured by the forward viewing camera, width of a lane of a road along which the equipped vehicle is traveling;

determining, at least in part via processing by the image processor of image data captured by the forward viewing camera, road curvature of the road along which the equipped vehicle is traveling;

identifying to the control the driver present in the equipped vehicle and capable of operating the equipped vehicle;

wherein identifying the driver is based at least in part on a seat position of the driver seat when the driver is

14

seated in the driver seat and has selected the seat position stored in a memory seat module of the equipped vehicle;

when the control is not operating in the driving assist mode and the identified driver is operating the equipped vehicle, determining driving conditions while the equipped vehicle is driven by the identified driver;

when the control is not operating in the driving assist mode and the identified driver is operating the equipped vehicle, providing to the control information pertaining to operation by the identified driver of the equipped vehicle while the equipped vehicle is driven by the identified driver, and wherein the provided information pertains at least to (i) acceleration of the equipped vehicle by the identified driver, (ii) braking of the equipped vehicle by the identified driver and (iii) steering of the equipped vehicle by the identified driver;

when the control is not operating in the driving assist mode and the identified driver is operating the equipped vehicle, and responsive at least in part to image processing by the image processor of image data captured by the forward viewing camera, creating a personalized parameter set for the identified driver present in the equipped vehicle based on how the identified driver controls driving of the equipped vehicle during the determined driving conditions;

wherein the created personalized parameter set for the identified driver present in the equipped vehicle comprises how the equipped vehicle accelerates, brakes and steers the equipped vehicle while the equipped vehicle is driven by the identified driver during the determined driving conditions;

when the control is operating in the driving assist mode and the identified driver present in the equipped vehicle is not operating the equipped vehicle, and responsive to a current driving condition of the equipped vehicle, controlling the equipped vehicle (i) in accordance with the personalized parameter set for the identified driver present in the equipped vehicle and (ii) at least in part in accordance with image processing by the image processor of image data captured by the forward viewing camera;

wherein, when the control is operating in the driving assist mode, the control allows temporary overriding of the driving assist mode, without disabling the driving assist mode, by takeover of driving control of the vehicle by the driver;

responsive at least in part to the driver temporarily overriding the driving assist mode while the control is still operating in the driving assist mode, updating the personalized parameter set for the identified driver present in the equipped vehicle, and wherein the update of the personalized parameter set is based at least in part on action of the driver when the driver is temporarily overriding the driving assist mode while the control is operating in the driving assist mode;

wherein, when the control is not operating in the driving assist mode, generating a lane departure alert responsive to determination that the vehicle is moving toward a lane marker of the lane of the road along which the equipped vehicle is traveling; and

adjusting a threshold level at which the lane departure alert is generated as the vehicle moves towards the lane marker or out of the lane in which the vehicle is

traveling in accordance with the personalized parameter set for the identified driver present in the equipped vehicle.

17. The method of claim 16, wherein creating the personalized parameter set for the identified driver present in the equipped vehicle comprises creating the personalized parameter set for the identified driver present in the equipped vehicle by learning, while the identified driver is driving the equipped vehicle, at least one parameter indicative of the identified driver's preference for operation of or use of at least one accessory or system of the equipped vehicle.

18. The method of claim 16, wherein the control, when operating in the driving assist mode, provides at least one of (i) adaptive cruise control for the equipped vehicle, (ii) lane keep assist for the equipped vehicle and (iii) lane centering for the equipped vehicle.

19. The method of claim 16, wherein the created personalized parameter set for the identified driver present in the equipped vehicle comprises (i) how rapidly the equipped vehicle, when driven by the identified driver, accelerates if a preceding vehicle changes lane and is no longer in the lane along which the equipped vehicle is traveling, (ii) how aggressively the equipped vehicle, when driven by the identified driver, decelerates after a cut-in by another vehicle into the lane along which the equipped vehicle is traveling, and (iii) how the speed of the equipped vehicle, when driven by the identified driver, is adjusted responsive to approach of the equipped vehicle to road curves ahead of the equipped vehicle.

* * * * *