

Oct. 1, 1940.

O. OECKL ET AL

2,216,403

DRILLING AND RIVETING MACHINE

Filed May 23, 1939

14 Sheets-Sheet 1

Fig. 1

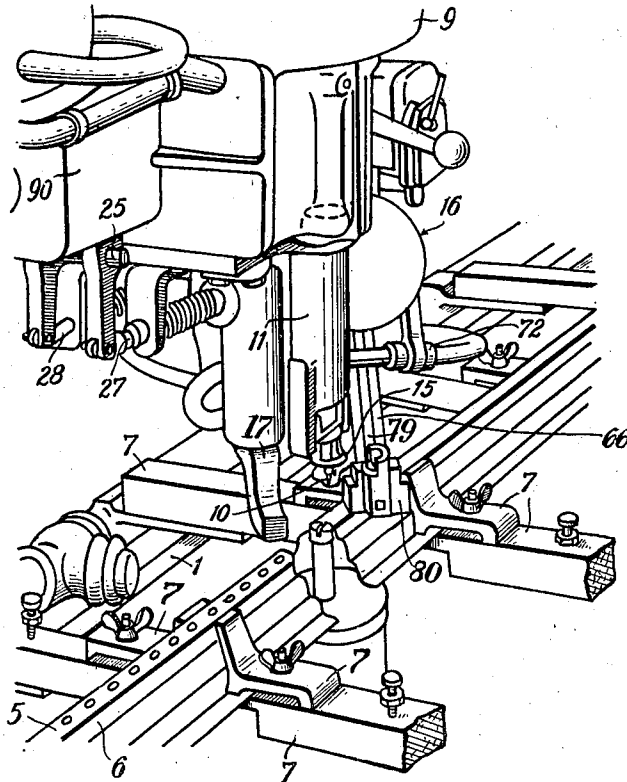

INVENTORS
O. Oeckl
H. Weinholt
W. Fleiter and
L. Kessler

BY

E. F. Kunderoth

ATTORNEY

Oct. 1, 1940.

O. OECKL ET AL

2,216,403

DRILLING AND RIVETING MACHINE

Filed May 23, 1939

14 Sheets-Sheet 2

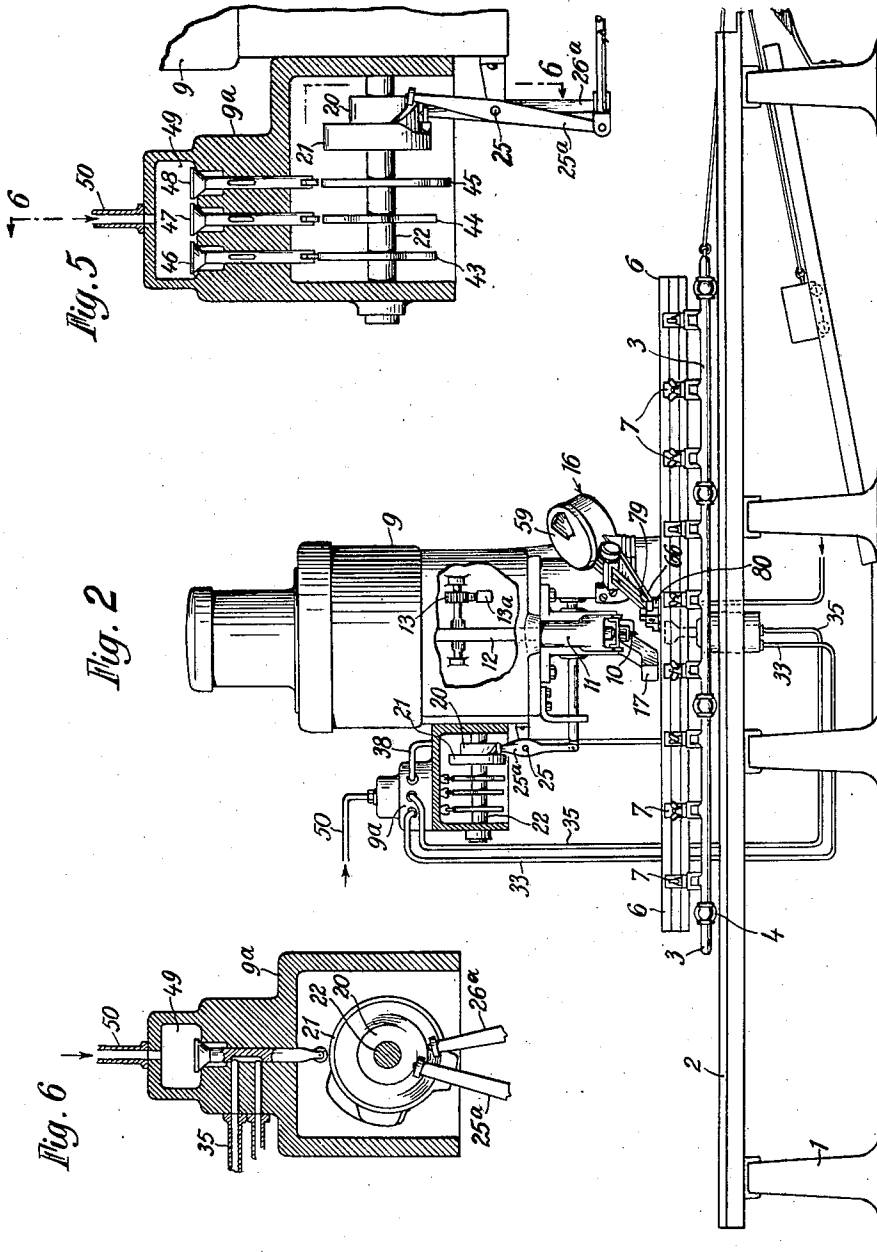

INVENTORS
O. Oeckl
K. Weirhold
W. Fleines and
L. Kessler

BY

E. F. Wendroth

ATTORNEY

Oct. 1, 1940.

O. OECKL ET AL

2,216,403

DRILLING AND RIVETING MACHINE

Filed May 23, 1939

14 Sheets-Sheet 3

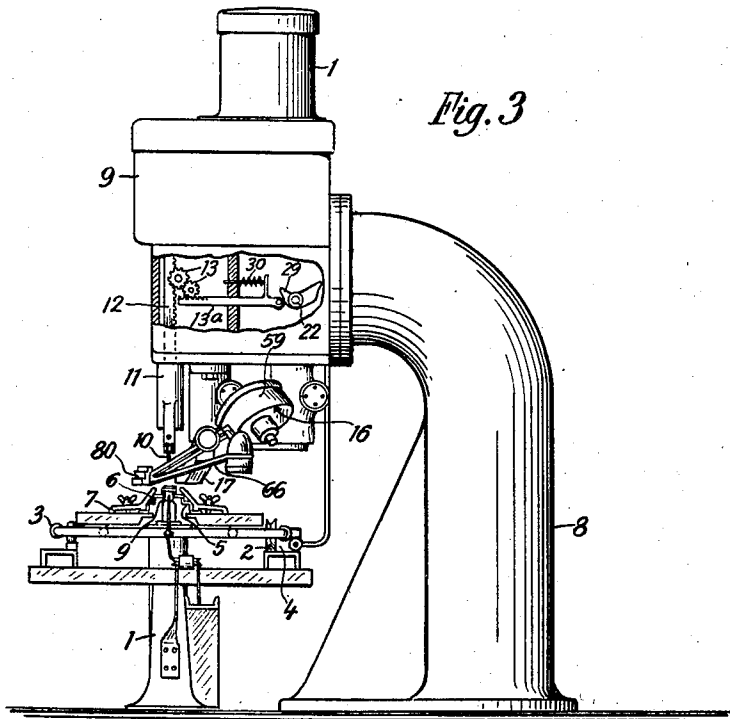

Fig. 3

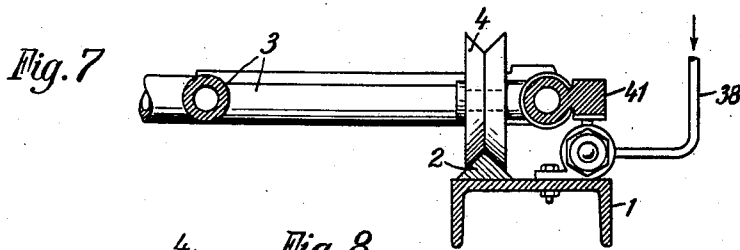

Fig. 7

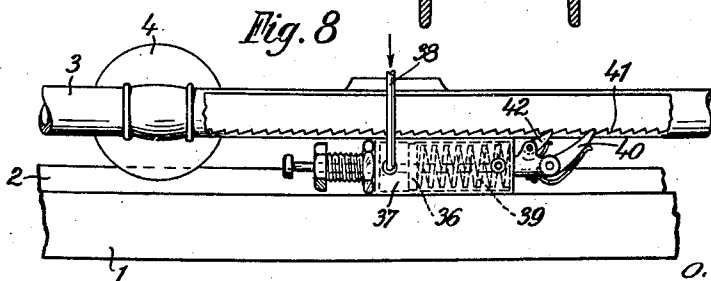

Fig. 8

INVENTORS
O. Oeckl
H. Weirhold
W. Pleines and
L. Hessler

By

E. F. Wendroth

ATTORNEY

Oct. 1, 1940.

O. OECKL ET AL

2,216,403

DRILLING AND RIVETING MACHINE

Filed May 23, 1939

14 Sheets-Sheet 4

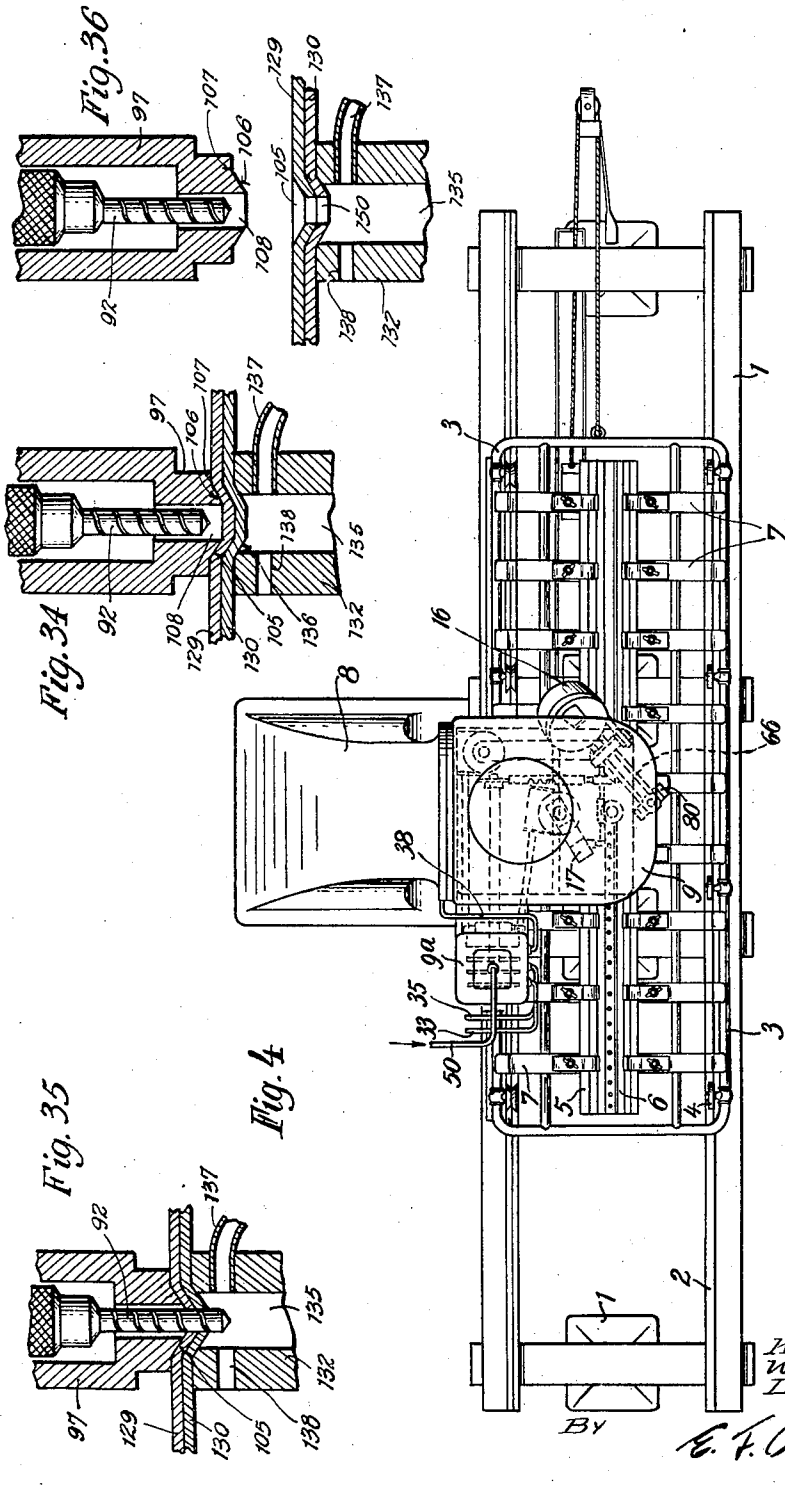

INVENTORS
O. Oeckl
K. Weirhold
W. Pleines and
L. Hessler

BY
E. F. Ouedvott
ATTORNEY

Oct. 1, 1940.

O. OECKL ET AL

2,216,403

DRILLING AND RIVETING MACHINE

Filed May 23, 1939

14 Sheets-Sheet 5

Fig. 12

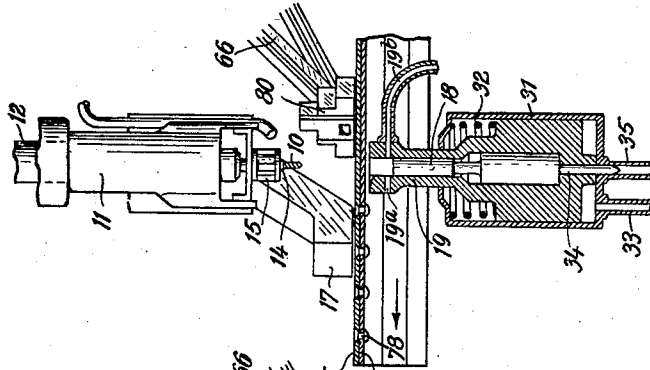

Fig. 11

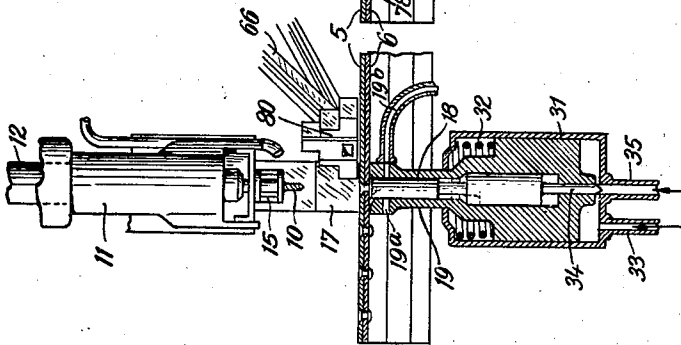

Fig. 10

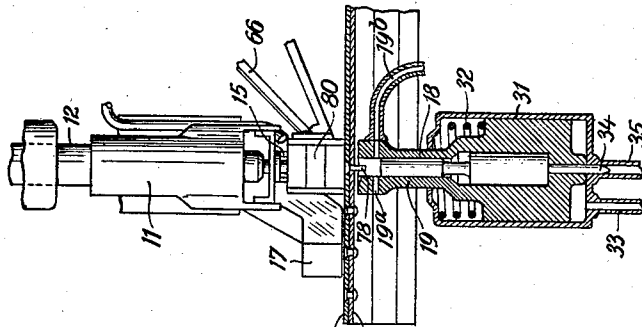
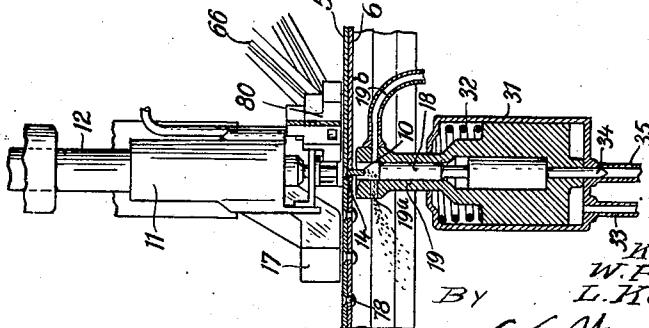

Fig. 9



INVENTORS
O. Oeckl
H. Weithold
W. Pleines and
L. Kessler
BY
G. F. Mendenhall
ATTORNEY

Oct. 1, 1940.

O. OECKL ET AL

2,216,403

DRILLING AND RIVETING MACHINE

Filed May 23, 1939

14 Sheets-Sheet 6

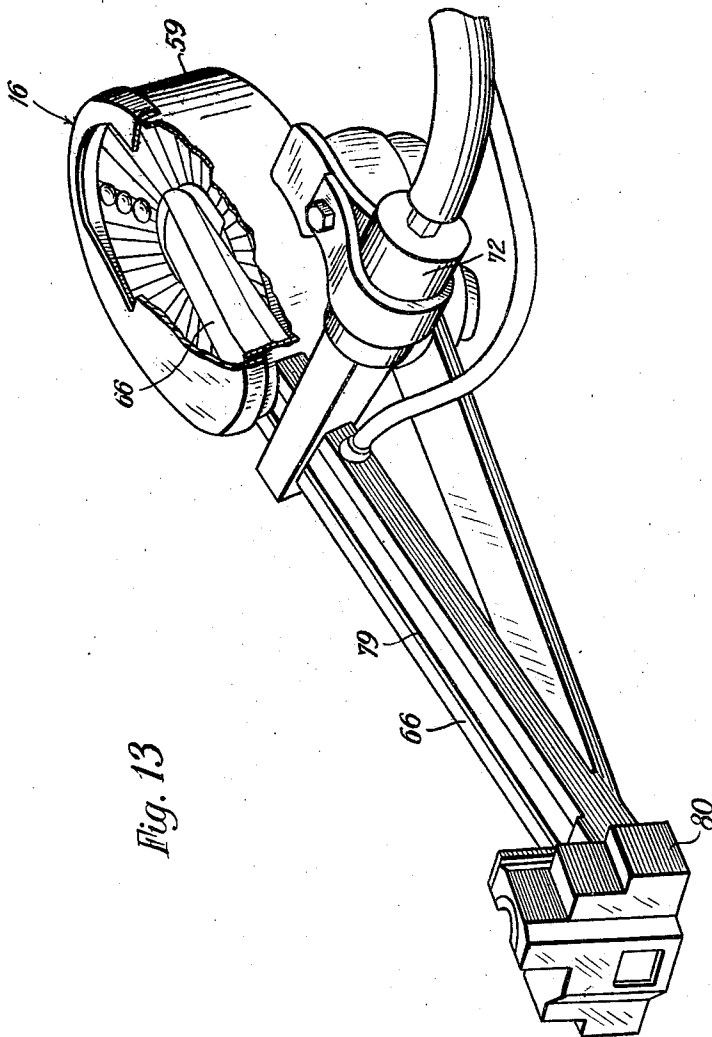

Fig. 13

BY

INVENTORS
O. Oeckl
H. Weinholt
W. Pleines and
L. Kessler

G. F. Okenbroth

ATTORNEY

Oct. 1, 1940.

O. OECKL ET AL

2,216,403

DRILLING AND RIVETING MACHINE

Filed May 23, 1939

14 Sheets-Sheet 7

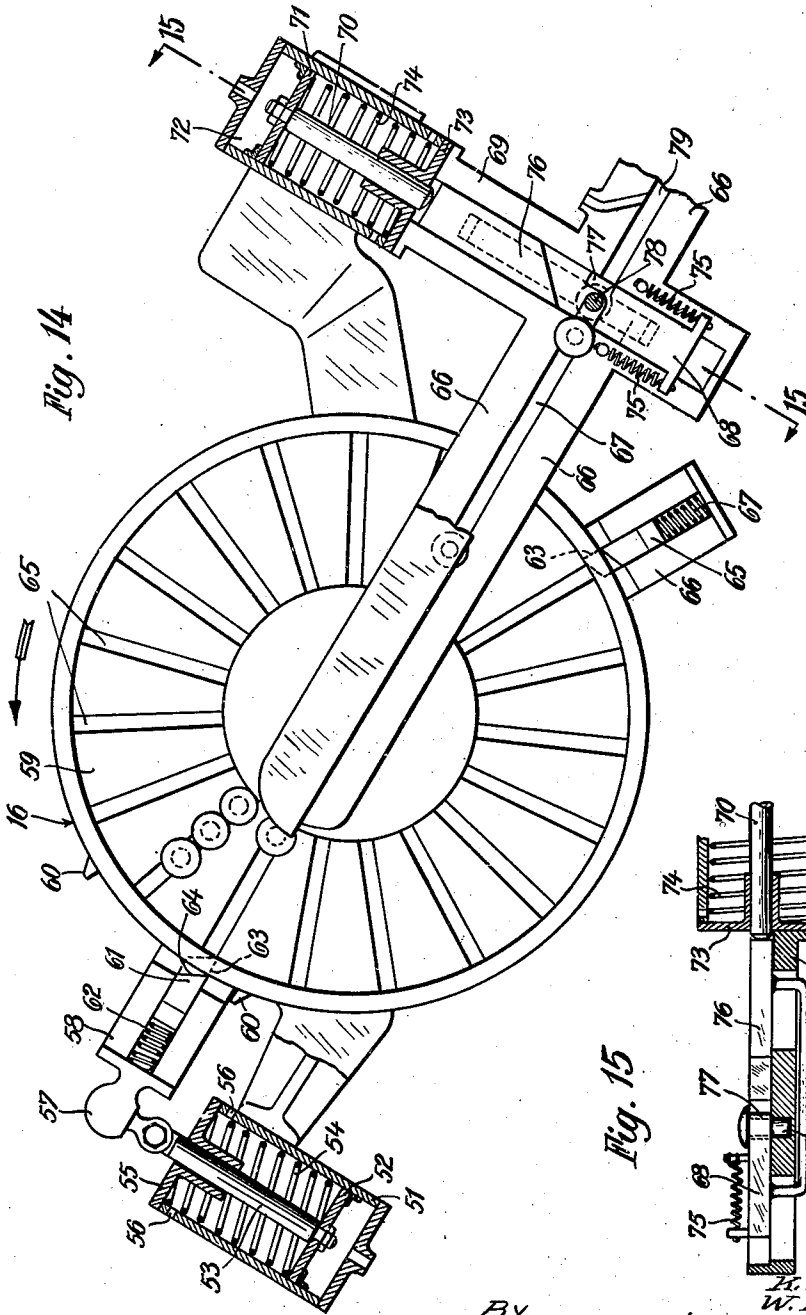

Fig. 14

Fig. 15

BY

K. F. Wendroth

INVENTORS
O. Oeckl
A. Weirhold
W. Pleines and
L. Kessler

ATTORNEY

Oct. 1, 1940.

O. OECKL ET AL

2,216,403

DRILLING AND RIVETING MACHINE

Filed May 23, 1939

14 Sheets-Sheet 8

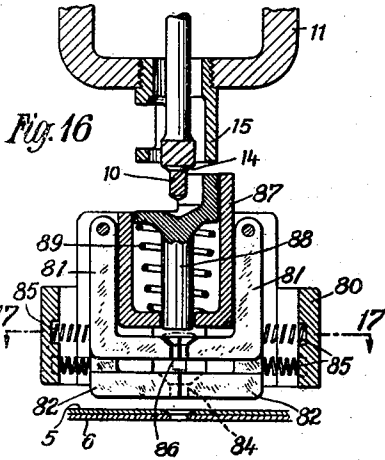

Fig. 19

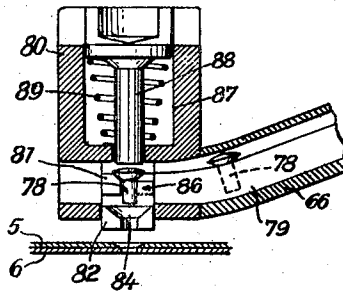

Fig. 17

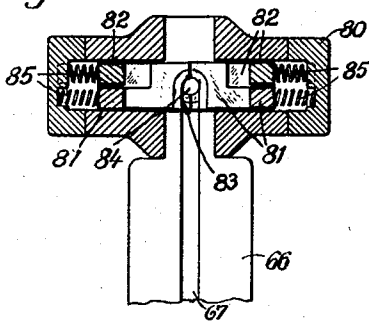

Fig. 20

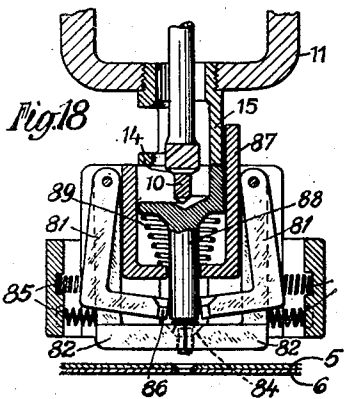
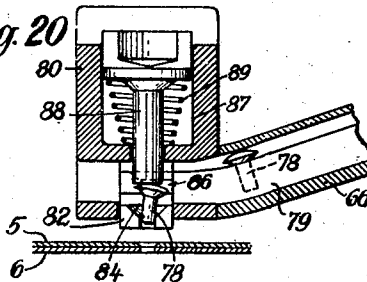
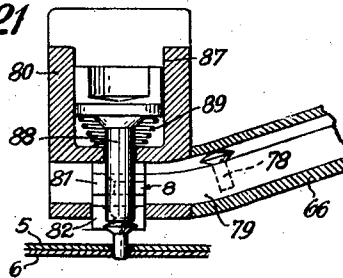

Fig. 21



INVENTORS
O. Oeckl
K. Wernhold
W. Pleines and
L. Hessler

By *E. F. Wendroth*
ATTORNEY

Oct. 1, 1940.

O. OECKL ET AL

2,216,403

DRILLING AND RIVETING MACHINE

Filed May 23, 1939

14 Sheets-Sheet 10

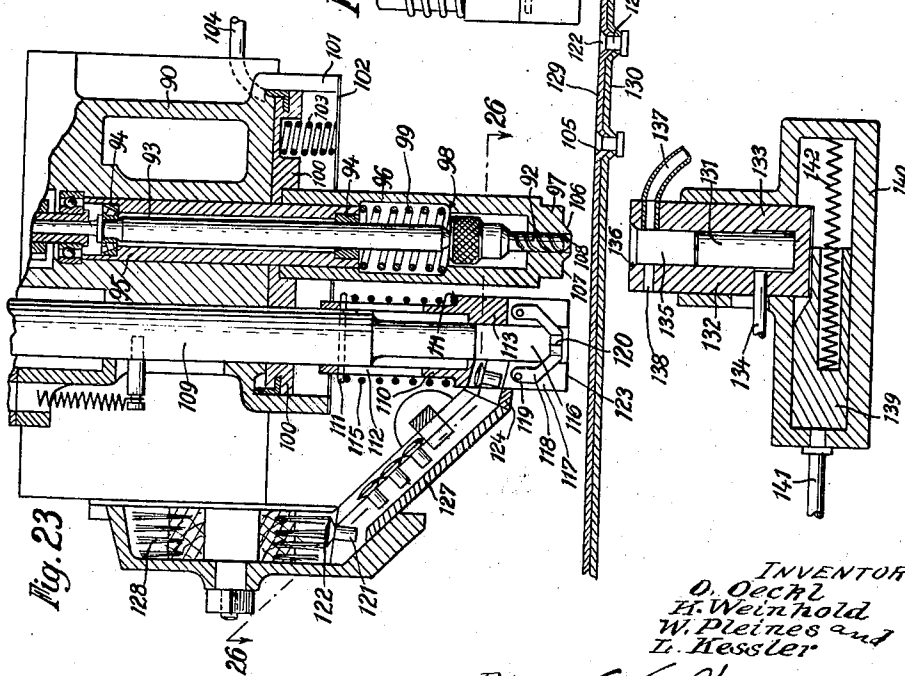
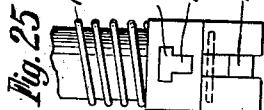
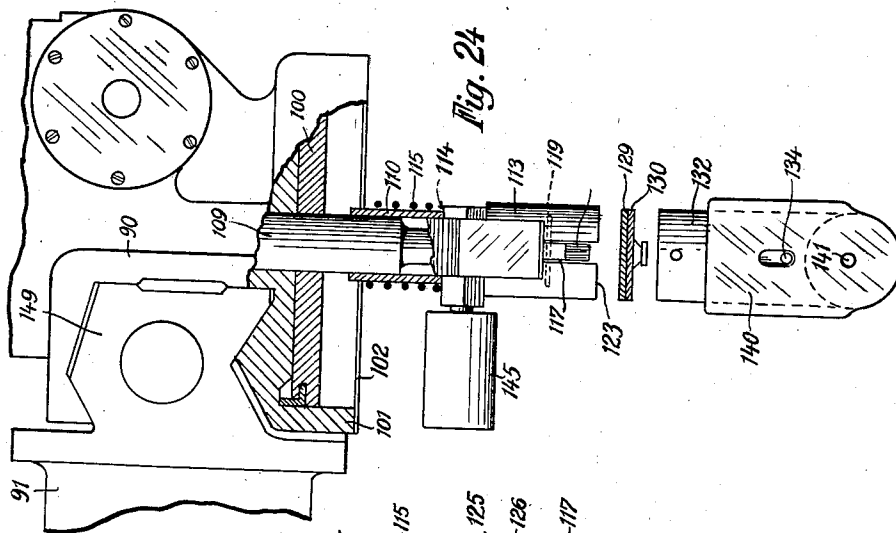

INVENTORS
O. Oeckl
E. Weirhold
W. Pleines and
L. Kessler

BY *E. F. Schroth*
ATTORNEY

Oct. 1, 1940.

O. OECKL ET AL

2,216,403

DRILLING AND RIVETING MACHINE

Filed May 23, 1939

14 Sheets-Sheet 11

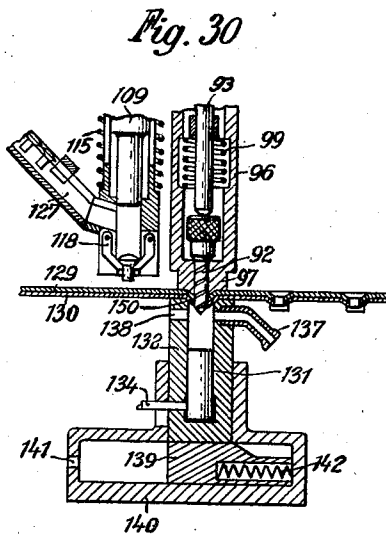
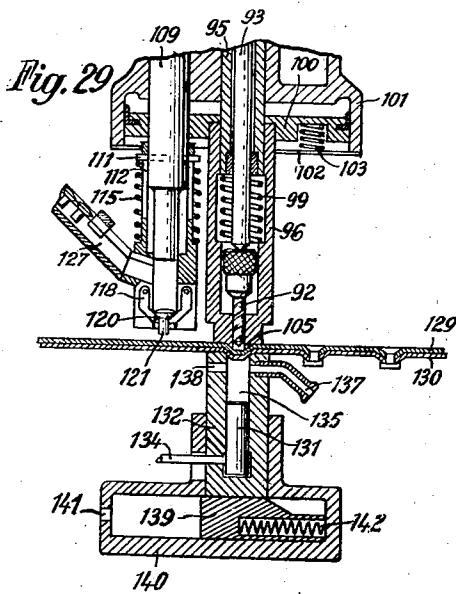
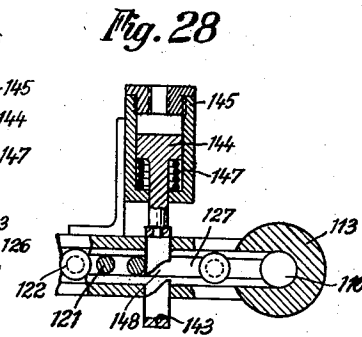
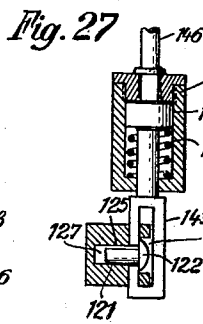
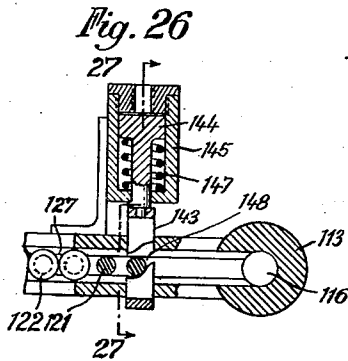

INVENTORS
O. Oeckl
H. Weirhold
W. Plettes and
L. Kessler

By

E. F. Kenderoth

ATTORNEY

Oct. 1, 1940.

O. OECKL ET AL

2,216,403

DRILLING AND RIVETING MACHINE

Filed May 23, 1939

14 Sheets—Sheet 12

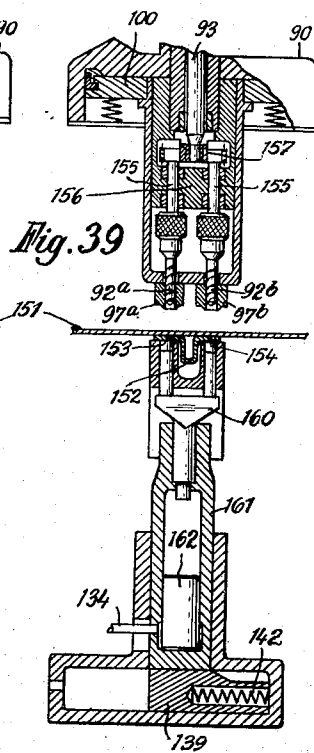
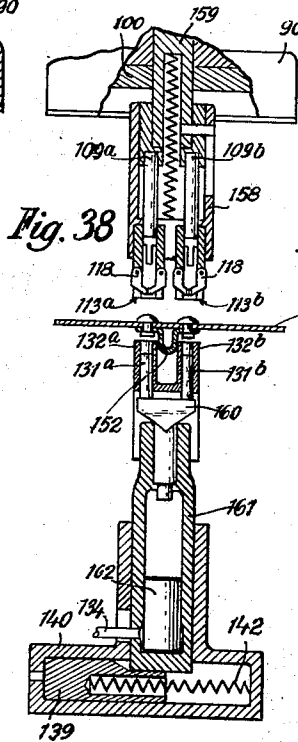
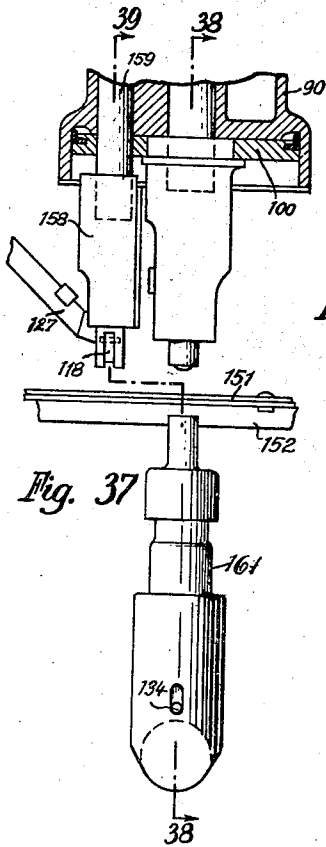
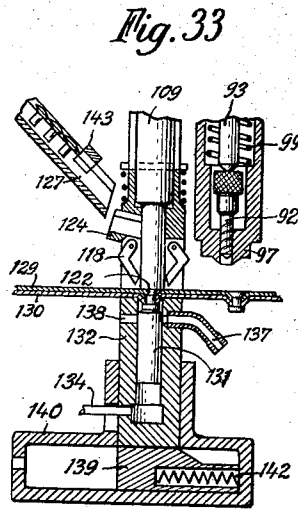
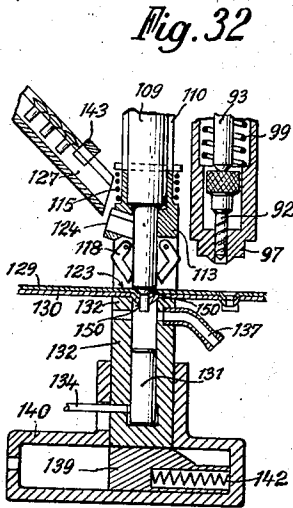
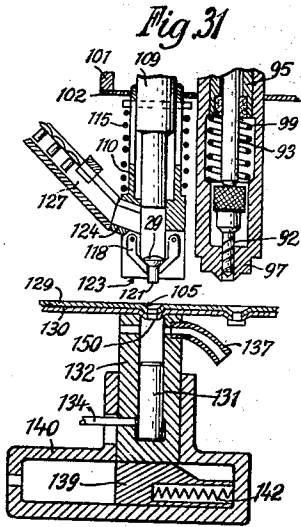

By

E. F. Orendorff

ATTORNEY

INVENTORS
O. Oeckl
K. Weirhold
W. Pleitjes and
D. Hessler

Oct. 1, 1940.

O. OECKL ET AL
DRILLING AND RIVETING MACHINE

2,216,403

Filed May 23, 1939

14 Sheets-Sheet 13

Fig. 40

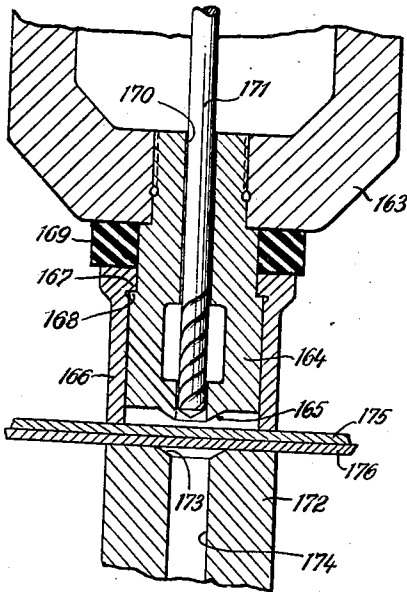

Fig. 41

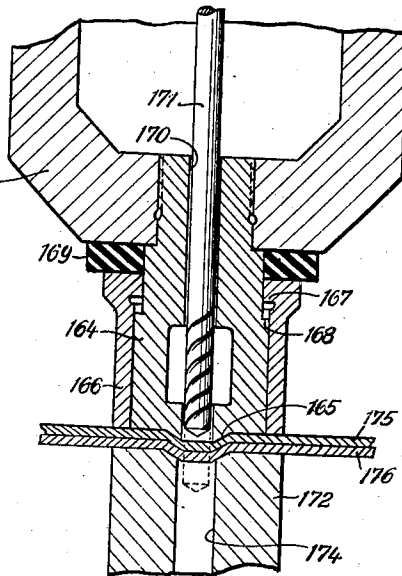

Fig. 42

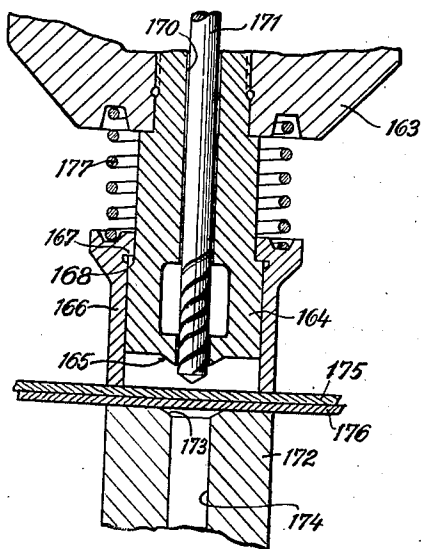
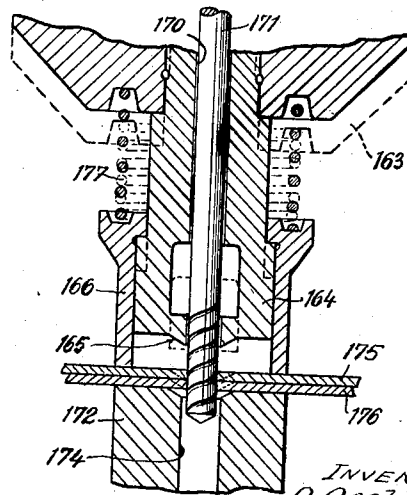

Fig. 43



BY

INVENTORS
O. Oeckl
H. Weinholt
W. Pleitner and
L. Kessler
E. F. Wendt
ATTORNEY

Oct. 1, 1940.

O. OECKL ET AL

2,216,403

DRILLING AND RIVETING MACHINE

Filed May 23, 1939

14 Sheets-Sheet 14

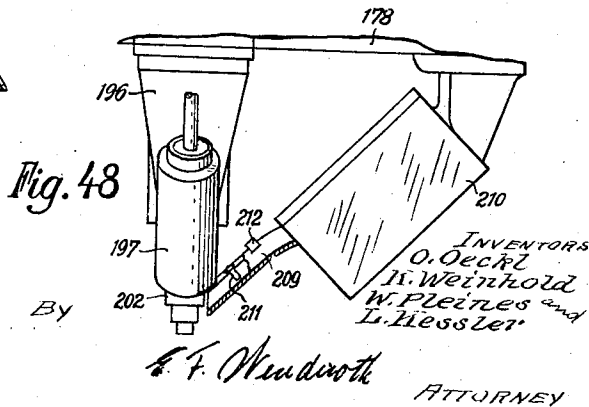
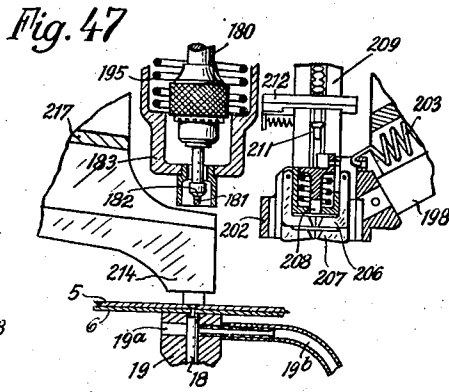
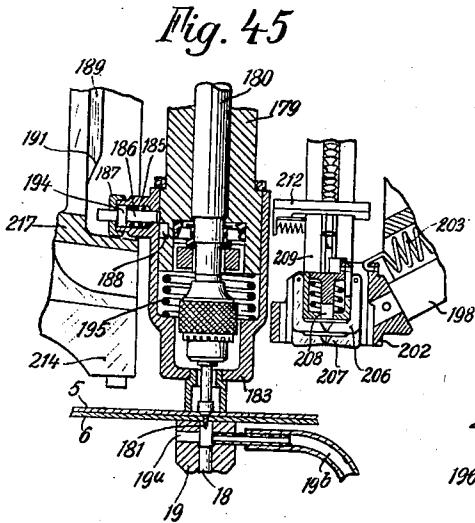
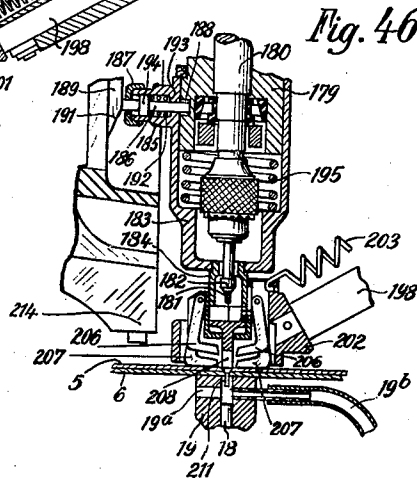
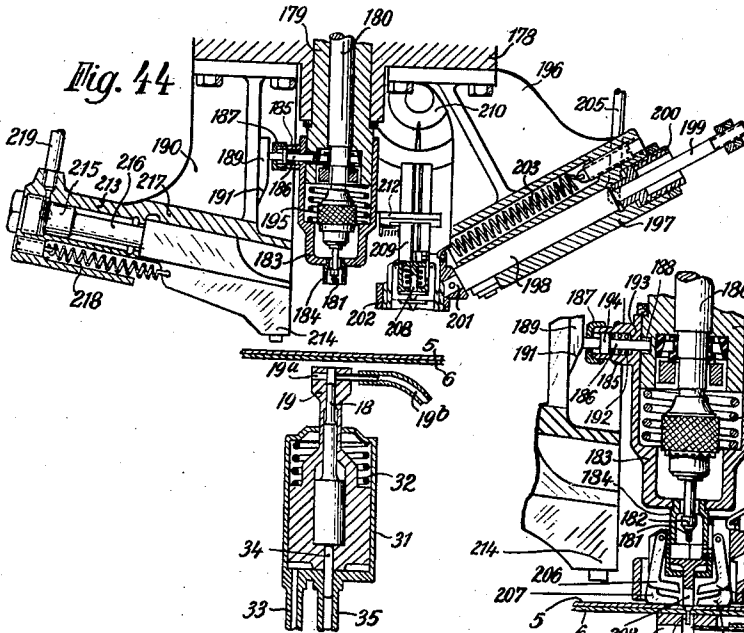

UNITED STATES PATENT OFFICE

2,216,403

DRILLING AND RIVETING MACHINE

Otto Oeckl, Berlin, and Karl Weinhold, Wilhelm Pleines, and Leo Kessler, Frankfort, Germany, assignors to Frankfurter Maschinenbau-Akt.-Ges. vorm. Pokorny & Wittekind, Frankfort-on-the-Main, Germany

Application May 23, 1939, Serial No. 275,272
In Germany May 30, 1938

20 Claims. (Cl. 29—26)

This invention relates to a drilling and riveting machine.

The object of the invention is to provide a machine by which long and relatively thin sheets or plates, such as are used in particular in aircraft construction, can be riveted together automatically and quickly and the operating tools can be easily supervised. Further, the surface of the plates riveted together in the machine is smooth which, in aircraft construction, is of considerable importance for reducing wind and air resistance.

An object of the invention is to simplify and accelerate the operation of drilling and riveting machines by connecting the countersinking tool directly to the drill and a rivet feeding device, which is automatically swung over the rivet hole.

The automatic operation of the machine might be upset if turnings or filings entered the plate-clamp surrounding the hammer. In machines using a template this has previously been constructed as a guide for the riveting hammer and a radial passage opening into the guide has been provided in it and the hammer piston has been lowered so that this passage was free during the drilling. The complete removal of the borings can be effected by mechanical means only with great difficulty. A further object of the invention, therefore, is to provide opposite a lateral opening in the plate-clamp which is not closed by the hammer during the drilling operation an opening to which a compressed air pipe is connected. If the compressed air is connected while the borings or filings are still in movement, their complete removal is automatically ensured.

In a drilling and riveting machine in which the counter-support and the rivet guide device are swung over the rivet hole and the drilling tool combined with the counter sinker used as a rivet-driving punch, the drill spindle must describe a relatively great stroke. As a result the spindle is given a relatively great mass acceleration, which, in rapid operation, causes undesirable vibration.

In order to avoid this mass acceleration, according to the present invention there is mounted on a common support movable in the direction of the rivet seam or joint the drilling tool combined with the countersinker, and laterally thereof the automatic rivet guide device, a rivet driving punch, and a stripper adapted to be raised and lowered and cooperating with the plate holder during the driving in of the rivet whereby, during the formation of the closing head the rivet punch remains as a countersupport on the rivet. As a

result of the arrangement of a special rivet punch and the mobility of the tool above the table, after the hole is made, the drilling tool can be moved out of the axis of the rivet hole and the riveting punch with the plate holder, and the corresponding part of the rivet guide device can be carried to the axis of the rivet hole. The drilling tool need thus describe only a small stroke, so that on high speed operation injurious vibrations or shocks are avoided. An advantage is provided in that the machine can be rapidly operated for countersinking rivets in long plates with very easy service.

According to the invention the automatic rivet feed takes place in that the rivet feed passage is subdivided into a part which is attached to a common support of the countersink punch and the rivet driving punch, and a part adapted to be raised and lowered with the rivet drive punch and which, in raised position, is connected with the part attached on the support. In this position a rivet in the part attached to the support is released, while this passage part is closed off when the rivet inserting device lowers. The drilling tool, the countersink punch, the riveting punch and the automatic rivet feed device then form a commonly movable unit.

In riveting thin plate with countersunk rivets the countersinker is preferably formed not as a countersink punch, in order to form or sink a rivet hole without any cuttings. In order to obtain an exactly cylindrical wall of the rivet hole, without requiring subsequent or finishing drilling, the countersink must first be made by the countersink punch and then the rivet hole made.

In order successively to countersink and drill in one operation, without moving the plate, while retaining the countersinking and drilling succession, according to the invention, the perforating tool, thus a drill or punch, is arranged within the countersinker and the perforating tool begins its operation in the countersinker only when the latter, after forming the countersink, is seated on the plate. Thereby the perforating tool is preferably arranged in the axis of the countersinker.

If, before the countersinking or the drilling, the thin plates are to be pressed together in the direction of the countersink or perforating tool by means of a plate holder, clamp or the like, according to the invention the latter is disposed on the countersinker or its support. The advantage thereof is that the plate closer or retention, the countersinking and the drilling can be done in a single operation. After the opera-

tion is completed the plate closer with the countersinker removes automatically from the plate.

The perforating tool, drill or punch disposed in the countersinker is preferably slidable axially with respect to the latter. In this manner, after the plate is closed or clamped the series of further operations can be selected as desired. For example, the plate can first be countersunk and then drilled or the reverse can also be done, that is, first the drilling and then the countersinking.

For automatic operation of the plate closer, according to the invention, there is provided a yieldable intermediate member which is disposed between the plate closer, preferably formed as a sleeve, and its support. The yieldable intermediate member may consist, for example, of a runner ring or also of a spiral spring.

With these and other objects which will become apparent from the detailed description below various modifications of the invention are shown in the drawings, in which

Figure 1 is a partial perspective view of one embodiment of the invention,

Figure 2 is a front elevational view with portions in section of the embodiment shown in Figure 1,

Figure 3 is a lateral elevational view of Figure 2 with portions broken away and shown in section,

Figure 4 is a plan view of the construction shown in Figure 2,

Figure 5 is a sectional view on an enlarged scale of a portion of the construction illustrating the compressed air control,

Figure 6 is a sectional view taken on the section line 6—6 of Figure 5,

Figure 7 illustrates on enlarged scale a detail of the construction shown in Figure 2,

Figure 8 is a lateral elevation of the construction shown in Figure 7,

Figure 9 is an elevational view of a portion of Figure 2 with parts in section illustrating the elements in one operating position,

Figure 10 is a view similar to that shown in Figure 9 with the elements in another operating position,

Figure 11 is a view similar to that shown in Figure 9 with the elements in a still other operating position,

Figure 12 is a view to that shown in Figure 9 with the elements in a still further different operating position,

Figure 13 is a perspective view on enlarged scale with parts broken away showing the automatic rivet feeder,

Figure 14 is a plan view of Figure 13 with parts shown in section illustrating the passage of the rivets to the rivet feeder,

Figure 15 is a cross sectional view taken on the section line 15—15 of Figure 14,

Figure 16 is a cross sectional view of a detail on an enlarged scale illustrating the insertion of the rivets in the rivet hole,

Figure 17 is a horizontal sectional view taken on the section line 17—17 of Figure 16,

Figure 18 is a view similar to Figure 16 showing the parts in a different operative position,

Figure 19 is a vertical sectional view through a portion of the construction shown in Figure 16,

Figure 20 is a view similar to that shown in Figure 19 with the parts in a different operative position,

Figure 21 is a view similar to Figure 19 with the parts in a still different operative position,

Figure 22 is a partial perspective exploded view

illustrating the controls and drive for the rivet feeder, the counter-support and the drill as well as the compressed air control for the plate closer and the table advance,

Figure 23 is a partial sectional view illustrating a modified construction,

Figure 24 is a lateral elevational view of the modification shown in Figure 23 with portions in section,

Figure 25 is a partial lateral elevation of the rivet inserting device,

Figure 26 is a cross sectional view taken on the section line 26—26 of Figure 23,

Figure 27 is a cross sectional view taken on section line 27—27 of Figure 26,

Figure 28 is a view similar to Figure 26 with the parts in a different operative position,

Figure 29 is a view similar to Figure 23 of a portion thereof showing the parts in a different operative position,

Figure 30 is also a similar view to Figure 23 of a portion thereof with the parts in a different operative position,

Figures 31, 32 and 33 are similar views of a portion of the construction shown in Figure 23 with the elements in different operative positions,

Figure 34 is a longitudinal section of a portion of the countersink punch and drill as well as the plate closer used with the modification of Figure 23 on enlarged scale,

Figures 35 and 36 are views similar to Figure 34 illustrating the elements in different operative positions,

Figure 37 is a partial front elevational view with parts shown in section illustrating a modification of the construction shown in Figure 23,

Figure 38 is a cross sectional view taken on section line 38—38 of Figure 37,

Figure 39 is a cross sectional view taken on section line 39—39 of Figure 37,

Figure 40 is a longitudinal sectional view illustrating a modification of the structure shown in Figure 34,

Figure 41 is a similar view to Figure 40 showing the parts in a different operative position,

Figure 42 is a longitudinal sectional view illustrating a modification of the construction shown in Figure 40,

Figure 43 is a similar view to Figure 42 showing the parts in a different operative position,

Figure 44 is a partial cross sectional view with parts in elevation illustrating a still further modification of the invention,

Figure 45 is a view similar to that shown in Figure 44 and illustrating a portion thereof showing the parts in a different operative position on enlarged scale,

Figure 46 is a view similar to Figure 45 showing the parts in a different operative position,

Figure 47 illustrates a portion of the construction shown in Figures 45 and 46 with the parts in a different operative position, and

Figure 48 is a lateral elevation of the construction shown in Figure 44.

In order to obtain a plane surface countersunk rivets are employed. For riveting long plates with countersunk rivets the automatic drilling and riveting machine in accordance with the invention is constructed in the following manner. The drilling tool is formed as a combined drill and a countersinking tool and, above the sheets or plates which are clamped on a table having an automatic feed, there is arranged on the one side of the drill a rivet feeding device which can be swung over the drilled hole

and on the other side of the drill a counter-abutment for the rivet hammer, which abutment can be swung over the countersunk head of the rivet.

5 Below the sheets or plates there is provided a clamping member which encloses the riveting hammer and can be moved upwards and downwards by which the plates are pressed together. With a machine in which the tools coact in the
10 manner described, the mechanics have only to clamp the sheets and unclamp them, so that the machine can be attended to by unskilled workmen. The machine works rapidly since the drilling and countersinking take place in one operation and the rivet feeding device is swung over
15 the rivet hole while the drill is being raised and the counter-abutment for the hammer is swung over the countersunk head of the rivet while the feeding device is being swung back, and, on
20 lowering the clamp by which the plates are pressed together, the riveted plates are released and are fed forwards by the automatic feed of the table by a distance equal to the spacing of the rivets without being obstructed in any way
25 by downwardly projecting rivet heads.

It is easy to observe whether the rivet holes have been properly drilled and the rivets have been fed into their proper position since the necessary implements are disposed above the
30 sheets or plates. Further no unevenness is caused on the surface of the plates, since, when the rivet head is formed by the hammer, the abutment for the hammer lies on the countersunk head of the rivet flush with the surface of the
35 plate.

In the embodiment of the machine according to Figs. 1 to 22, a slide or table 3, is slidable by means of rollers 4 on a frame 1 provided with the rails 2 (Figs. 2, 4 and 7). The slide is assembled of single tubular parts for lighter construction. The thin plates 5 and 6 to be riveted
40 together, are positioned manually, by means of the clamps 7, on the slide, which serves as a work table.

45 Arranged adjacent frame 1 is a standard 8 (Fig. 3) which has an upper part 9 in which the drive members for the individual tools are arranged. Arranged in the upper part 9, above the free space between the clamps 7 on the slide 3, is
50 the drill 10 which is attached to a support 11. This latter is connected to a rack 12 (Fig. 3) which is raised and lowered by the gears 13 and a rack 13a at the proper time. Connected directly with the drill 10 is the countersinker 14 (Fig. 16) which is constructed as a miller, and is encompassed by a collar 15 which serves as a stop in regulating the depth of the countersink and which is attached to the support 11 of the drill.
55

Disposed at one side, adjacent drill 10, is the rivet feeder 16, which is adapted to be swung over the drill hole, and on the other side, near the drill, the counter-support 17, likewise adapted to be swung over the drill hole.
60

Below the plates 5 and 6 to be riveted, the riveting hammer 18 is arranged, so that its axis lies in alignment with that of drill 10. The riveting hammer 18 is encompassed by an ascending and descending plate closer 19, which latter is provided with a radial opening 19a which is positioned so that it is uncovered by the hammer when the latter is in the inoperative position. Opposite this opening the plate closer is provided with an opening to which the compressed air conduit 19b is connected.
70

75 The rivet feeder 16 and the counter-support 17

are driven mechanically by cam wheels 20 and 21 (Figs. 2 and 22). These cam discs are mounted on a shaft 22, which is set in rotational movement by any kind of drive motor. The cam discs co-operate with rollers 23 and 24 which are mounted on the ends of double levers 25a and 26a, rotatable about the pins 25 and 26. Piv-
10 otally engaged with the other ends of the double levers are the thrust rods 27 and 28, which are connected with the rivet feeder 16 and the counter-support 17 so that these can swing about vertical axes.

The drill 10 is raised through the gears 13 (Fig. 3) by means of the shaft 22 rotating a cam disc 29 which co-operates with the rack 13a (Figs. 13 and 22). Rack 13a is returned to its initial position by a push spring 30.
15

The plate closer 19 is constructed as a compressed air piston which moves in a cylinder 31 and is subject to the action of a spring 32. A compressed air conduit 33 terminates at the end of cylinder 31. Provided on the riveting hammer 18 is a piston element 34 penetrating to the end of cylinder 31 and which terminates in a compressed air conduit 35.

The movement or advance of the work table 3 takes place by means of a compressed air piston 36 which moves in a compressed air cylinder 37 (Figs. 8 and 22). A compressed air conduit 38 terminates in cylinder 37. Piston 36 is subject to the action of a counter-spring 39. Pivoted to the end of the piston extending from the cylinder is a shift pawl 40 which engages in the teeth of a rack 41, which is attached to the slide 3. The cooperating pawl 42 is also attached to the rod
35 of piston 36.

Attached to the shaft 22, in the extension 9a of the head 9 are three cams 43, 44 and 45, which cooperate with the plungers of the valves 46, 47 and 48 mounted in the head 9a (Figs. 5, 6 and 22).
40 Compressed air is introduced through a conduit 50 into the chamber 49 (Fig. 5) toward which the valves open. The valve plungers are constructed as slides, so that on opening of the valves the compressed air can pass from the chamber 49
45 through the passages provided in the extension 9a to the compressed air conduits 33, 35 and 38.

The automatic rivet feed apparatus 16 will now be described. The embodiment shown in Figs. 13 to 15 is provided with an inclined reservoir or drum for the counter-sunk rivets, which are progressively moved so that the rivets slide in an inclined, downwardly directed collecting passage in which there is a controlled sluice or passage, so that one rivet passes into the head of the appa-
55 ratus at the proper time where, with the aid of the depth stop 15 (Figs. 10 and 11), it is inserted in the rivet hole.

The piston 52 with its rod 53 moves in the fixed cylinder 51 (Fig. 14). The compressed air-controlled piston 52 is loaded with respect to the cylinder end 55 by means of a spring 54. The function of the air holes 56 is to avoid air cushions in the space between the piston and the cylinder end. The piston rod 53 is connected by a ball
60 joint 57 with a sleeve 58, which is rocked or swung about the rotational axis of the drum or reservoir 59. The rocking movement is limited by fixed abutments 60. The bevelled drive member 61, which is movable in the sleeve 58, is forced by a 70
spring 62 toward the periphery of the drum and engages in a depression 63 on the drum periphery. The dotted lines in Fig. 14 show its position in engagement with one of the depressions 63.

The bevel 64 permits the member 61 to slide out 75

of the depression 63 when the drum is stationary and the member is swung in a direction opposite that of the arrow (Fig. 14). When compressed air is delivered to the piston 52 and the rocking of the sleeve 58 is caused thereby, the drive member 61 passes from the depression 63, as in this case the drum 59 is held fast by means of a bevelled counter-retaining pawl 65, which is guided in a fixed sleeve 66 and is forced by a spring 67 into the corresponding depression 63 of the drum periphery. In this manner the drum can move only in the direction of the arrow.

When the sleeve 58 passes into the end position corresponding to the movement of the piston, the member 61, which slides on the periphery of the drum, snaps into a new depression 63. If piston 52 is relieved of the air pressure, the spring 54 returns it promptly to the initial position. The member 61 thereby carries along the drum 59 in the direction of the arrow, so that a new rivet-receiving slot 65 passes in front of the rivet collecting bar 66 with the collecting passage 67. As a result of the abrupt impact-like piston movement the rivets, held in position by their weight, move or jump from the slot into the passage 67, which is interrupted by a tongue 68 which slides in a guide 69. The tongue 68 is controlled by a piston rod 70 attached to a piston 71. The latter is slidable in a pressure cylinder 72 connected with a compressed air conduit and is subject to the action of a spring 74 supported against the cylinder end 73.

The tongue 68 is forced by springs 75 against the piston rod 70 and has a slide 76 as well as a catch 77. In the position shown in full lines of the slide and catch a rivet 78 has passed from the passage 67 into the tongue in front of the catch 77. This prevents further passage of the rivet in the passage 79 formed by the bars 66, to the rivet inserting apparatus. If piston 71 is actuated by compressed air the catch and slide assume the lower (release) position, whereby the slide 76 passes in front of the collecting passage 67 while, through the simultaneous movement of the catch, the path to the passage 79 is opened up for the rivet in the tongue 68. When the piston is relieved of air pressure the springs 75 force the tongue 68 into the initial position. The catch 77 is again applied in front of the passage 79, while the slide 76 opens the passage 67 for the advance of a new rivet.

The rivet insertion takes place, according to Figs. 16 to 21, by means of two superposed jaw pairs. Disposed in the head 80 are two superposed spring jaw pairs 81 and 82, the upper 81 having an opening 83 formed by recesses in both jaws. This opening is semi-circular and forms the continuation of the feed passage 79 for the rivets, so that it is open toward this passage, while its limit, which serves as a stop for the advancing rivets, forms the end of the passage. The lower jaw pair 82 has an opening 84 not interrupted in its periphery and which is formed of corresponding recesses of both jaws. The diameter of this opening corresponds to that of the rivet shank. The lower jaw pair 82 is arranged below the pair 81 at a vertical distance somewhat smaller than the rivet length. Both pairs of jaws are pressed together by springs 85 supported in the head 80.

Above the opening 86 of the resilient jaw pair 81 a punch 88 is yieldably mounted in a sleeve 87 attached to head 80 and retained in the sleeve by means of a spring 89. The upper part of sleeve 87 is also formed semi-cylindrical, the opening of said half cylinder being directed toward the drill-

ing or perforating spindle of the machine. Thus, if the rivet feeder is swung into the operative position for the insertion of a rivet the spindle can enter into the cavity of the half cylinder and serve to depress the punch 88.

When the rivet feeder is rocked into the operative position the pressing spindle of the machine passes into the cavity of the half cylinder of sleeve 87, so that it is above punch 88. If, now, the pressure spindle of the machine is lowered on punch 88 the rivet, by the expansion of the jaws 81 is forced in the completely closed opening 84 of the lower jaw pair 82. As the distance of this pair from the other pair 81 is less than the rivet length the rivet shank passes into the opening 84 before it leaves the opening 86. The rivet is thus engaged completely all around by the jaw pair 82 and axially directed. Thereupon, through the expansion of the jaws 82, the rivet is forced through opening 84, whereby caution is observed that the jaws 82 lie above the plates 5 and 6 at a distance less than the rivet shank length, so that the rivet enters by its shaft into the drill hole before leaving the opening 84 of the jaw pair 82.

The operation of the machine is as follows:

On Fig. 12, the table 3 (Fig. 2), on which the plates 5 and 6 are held, has been advanced by the pawl 40 (Fig. 8) for a rivet spacing, so that the axis of the drill hole to be made coincides with that of the drill 10. If, now, according to Fig. 9, the drill is lowered by movement of the rack 12 and at the same time rotated, the drill hole is first bored, whereupon the countersink for the head of the sunken rivet is milled out by the countersinker 14, until the stop 15 is seated on the upper plate 5.

The cuttings resulting from the drilling are carried from the radial opening 19a by the compressed air stream coming through the conduit 19b and blown out of the cylinder of the hammer 18. The drill is thereupon drawn back to its position as stated by the spring 30 (Fig. 3), and during this movement the rivet feeder 16 is rocked by the rod 27 (Fig. 22) so that the axis of the punch 88 (Fig. 16) lies in the same range as that of the drill hole.

In the meantime a rivet has passed from the reservoir through the collecting passage and the discharge passage to the head of the rivet feeder. If, now, the drill is again lowered by the cam 29 (Fig. 18) acting on the rack 12, a rivet 78 is inserted in the hole. Immediately after re-ascend of the drill the rivet feeder 16 is swung back by rod 27 to the initial position, while the counter-support 17 is swung over the head of the counter-sunk rivet by the rod 28 (Fig. 22). By means of the cam disc 43 (Fig. 22) the corresponding valve in head 9 is raised so that compressed air can enter through passage 33 into cylinder 31, and in the plate closer 19 exerts pressure from below against the plates 5 and 6 (Fig. 11). Thereupon, through the cam disc 44, the corresponding valve is raised, so that compressed air passes through the passage 35 below piston rod 34, thus the head of the rivet being formed by the riveting hammer 18. Thereupon the counter-support 17 is again swung back to its initial position by the curve guide of cam wheel 21, and the plate closer 19 lowered, so that passage 33 is set in communication with the atmosphere. The work table 3 is then advanced for a further spacing (Fig. 12), as it is not prevented therefrom by the downwardly projecting closure heads.

5

10

15

20

25

30

35

40

45

50

55

60

65

70

75

75

Figs. 23 to 33 show a modification of the riveting machine, in which the object remains stationary during the drilling and riveting, although a riveting punch is provided which, together with the drill, is mounted on a support slidable in the direction of the rivet rows.

In the construction of the automatic drilling and riveting machine shown in Figs. 23 to 33, in the drill head 90, which is secured to the standard 91 shown on Fig. 24, the drill 92 is attached to a rod 93 which is mounted or journalled in the brackets or bearings 94 of a sleeve 95, the end of the latter extending into a tubular extension 96 of the countersinker 97. The extension 97 has a shoulder 98 against which a spring 99 is supported, which is applied against the front end of sleeve 95 and presses the latter against the upper bearing 94. The end of the extension 96 is attached to a compressed air piston 100 which is slidably journalled vertically of the drill head 90 in an annular flange 101 serving as a cylinder, and which is covered below by a sheet metal disc 102. Traction or return springs 103 are interposed between this disc and the piston 100. Compressed air is passed to the cylinder 101 through a conduit 104.

The countersinker 97 has the profile shown on Fig. 23 for making the countersink 105, which is a combination of a conical surface 106 and a connected horizontal annular surface 107.

The drill passes freely through a bore 108 of the sinker 97, the drill being then encompassed by the sinker punch 97.

The riveting punch 109 is journalled so as to raise and lower, in drill head 90, together with the drill and countersinking punch. Punch 109 passes freely through the piston 100 and the lower part thereof is encompassed by a sleeve 110 which is suspended to the punch by means of a pin 111 which is guided at its ends in vertical slots 112 of the sleeve.

At the lower end, the sleeve has a solid part 113 provided with a shoulder 114. A spiral spring 115 is interposed between this shoulder and the ends of pin 111. The solid part 113, which is provided with a bore 116 for the passage of the rivet-inserting punch 109, is provided with a diametric recess 117, in which a pair 118 of spring jaws is journalled oscillatably about the pivot pins 119. The jaw pair is provided, at the opposite ends, with semi-cylindrical recesses or depressions which are enlarged to an opening 120, corresponding to the shank 121 of the rivet. The jaws are so conformed that the head 122 of the rivet (Fig. 31) can lie on the jaws.

The part 113 extends somewhat over the jaws 118 to the rear and is there provided with straight supporting surfaces 123, which thus lie laterally of the bore 116.

Above the recess 117 the solid part 113 is provided with a member 124 having a T-shaped recess which is formed of the horizontal part 125 (Fig. 25) and the vertical part 126. This recess 125, 126 terminates in the bore 116 of the part 113. The member 124 forms part of an automatic rivet feeder and connected thereto is an inclined channel 127 which is provided with the same T-shaped cross section 125, 126 as the member 124 and is attached to the drill head 90. The upper end of channel 127 terminates in a rivet distributing device 121, 122 which, in the construction shown, is formed by a rotating brush.

Located below the plates 129 and 130 to be riveted together is the riveting hammer 131,

which is encompassed by a plate closer 132. The diagrammatically illustrated hammer is, for example, a compressed air hammer, the cylinder 133 of which is supplied with compressed air through a conduit 134. The plate closer 132 is provided at the delimitation directly encompassing the cylinder bore 135 with shoulders 136 (Fig. 23) corresponding to the countersink. A compressed air conduit can also terminate at the upper part of bore 135 in order to blow drill cuttings out through the opposite opening 138. The plate closer is raised and lowered in the construction shown by means of a wedge piston 139 which is horizontally slidable in a compressed air cylinder 140. The cylinder is supplied with compressed air through a passage 141. The piston 139 is returned by a pressure spring to its initial position.

For automatically feeding the rivets 121, 122, the feed passage 127 is provided with a slide 143 (Figs. 26 to 28) which acts something like a sluice and is controlled by a compressed air piston 144. Compressed air is supplied to the cylinder 145 through a conduit 146. The piston 144 is returned to its initial position by a spring 147. The slide 143 has a recess 148 such that in one position of the vertical part 126 (Fig. 25) it closes off the recess 125, 126 and thus lies in the path of the rivet shank 121, while in the other position it releases the shank.

The drill head 90 is longitudinally slidable in the direction of the rivet rows, and mounted for example on a swallowtail guide (Fig. 24), so that the riveting punch can be carried above the drill hole.

The operation of the machine is as follows:

If a new rivet is to be inserted and riveted the plates 129, 130 are advanced for a spacing, and the individual elements assume the position shown on Fig. 23, in which the drill 92, its encompassing countersink punch 97, the riveting punch 109 and the part 113 of sleeve 100 are at a distance above the plates. In this position the recess 125, 126 is connected with the member 124, and through slide 143 a rivet is released, which passes through the T-shaped recess 125, 126 into the bore 116 of the part 113, and, as shown on Fig. 29, enters by its shank 121 into the opening 120 of the jaws 118, its head thus suspended on the jaws.

By advancing the piston 139 into the position of Fig. 29 the cylinder 132 is first raised until it is applied on the plates 129 and 130, whereupon compressed air is admitted above piston 100, whereby the countersink punch 97 is pressed on the plates. The countersink 105 (Fig. 29) is thereby made by the conical surface 106. The plates are then held between the horizontal pressure surfaces 107 of the punch 97 and the horizontal surfaces of the cylinder 132 serving as a plate closer.

On descent of the countersinker 97 the drill 92 lowers therewith (Fig. 29). It is now lowered through control of the rod 93, whereby sleeve 95 is carried along and spring 99 compressed. On setting the drill 92 in operation an exactly cylindrical hole 150 (Figs. 30 and 31) is drilled in the conical surfaces of the plates 129 and 130.

On raising the rod 93, the drill 92 is drawn back into the countersink punch 97, and on discharging the compressed air from cylinder 101 the countersinker 97 together with the drill 92 is returned to the initial position of Fig. 23.

The drill head 90 is then moved to the right on the swallowtail guide 149 to such extent that

the axis of the riveting punch 109 coincides with the axis of the drill head 131, thus assuming the position of Fig. 31.

The riveting punch is then lowered and with it the sleeve 110 with its solid part 113, until this part is seated by its pressure surfaces 123 on the upper plate 129, so that the plates 129 and 130 are retained between the part 113 and the plate closer 132. On further descent of the riveting punch the spring 115 is compressed and, by means of the punch, the rivet is inserted in the hole 150, with the expansion of the resilient jaws 118. The head 122 thereby comes to lie in the countersink 105 (Fig. 32).

While compressed air is passed through the passage 134 to the compressed air hammer the riveting punch 109 remains on the rivet head 122 as a counter-support, so that the closure head of the rivet is formed by the hammer (Fig. 33).

In the position of Figs. 32 and 33 the one part of the passage forming the rivet feed channel is separated from the feed channel 127, and the slide 143 assumes the closure position of Fig. 28.

The punch 101 is first raised, this movement being supported by the spring 115. On further ascent of the punch the latter carries along the sleeve 110 and the part 113, until the parts return to the position of Fig. 23, in which the channel is again connected with the passage 127, so that another rivet can be released by the slide 143. Thereupon the drill head 90 is again moved back to the left, until the axis of the drill 92 is above that of the hammer 131. The plate closer 132 is again lowered, as the space behind the piston 139 is again put in communication with the atmosphere, so that the piston passes to the initial position of Fig. 23 through the action of the spring 142.

As a result of the possibility of bringing the drill 92 out of the axis of the hammer 131 after completing the drilling by moving the head 90, and of carrying the riveting punch 109 into this axis, the stroke of the drill rod 93, and thus also the vibrations produced thereby, are very small.

Figs. 34 to 36 diagrammatically show how the countersink punch 97 and the drill 92 cooperate, when the drill begins its working stroke, after the countersinker is applied on the plate.

As previously stated, the punch 97 is disposed so as to be raised and lowered, above the work table, and coaxial with the bore 135. The punch 97 is formed as a hollow member, in which the drill 92 is journaled so as to be raised and lowered. The drill 92 can pass freely through the bore 108 in the countersink punch.

The punch 97 together with the drill 92, which is still in the bore 108, is first lowered on the plates 129 and 130, which lie on the work table 3, whereby the countersink 105 (Fig. 34) is formed. Thereupon, the plates 129 and 130 being held between the table 3 and the punch 97, the drill 92 is lowered and the rivet hole 150 drilled (Fig. 35). The drill is then raised to the position of Fig. 34, whereupon the punch 97 and the drill 92 are raised into the position of Fig. 36.

As the countersink 105 is made first and then the hole 150 drilled, the latter is given the exactly cylindrical walls as shown on Fig. 36, so that in riveting the hole is completely filled by the rivet shank. The accurately cylindrical wall is assured in that the plates 129 and 130 are held between the countersink punch 97 and the work table 3 during the drilling.

If flaps or ribs are to be riveted on plates a

number of rivets may be provided simultaneously by arranging a correspondingly larger number of drills and countersinking punches encompassing them, in the drill head.

The construction according to Figs. 37 to 39 shows how a rib 152 is riveted with its lateral flanges 153 and 154 on the plate 151.

For this purpose, the drill head 90 is provided, instead of a single drill corresponding to the drill 92 of Fig. 23, with two drills 92a and 92b, spaced apart, and, correspondingly, also with two countersinking punches 97a and 97b, through which the drills can pass. The two drills are guided by means of the rods 155 in a guide member 156 and are suspended to a common crosspiece 157 attached to the spindle 93.

Like in the previously described constructions there are provided in the drill head 90, together with the drill, the riveting device and an automatic rivet feeder, and two riveting punches 109a and 109b are slidable in a common sleeve 158 by means of a spindle 159, and disposed below these punches are two spring jaw pairs 118, whereby the parts 113a and 113b serve as plate closers. Also, instead of one hammer 131, there are two hammers 131a and 131b provided on a riveting punch 160. The latter is disposed in the cylinder 161 of the hammer 162. Attached to this cylinder are also cylinders 132a and 132b, which serve as plate closers in the countersinking, drilling and riveting.

The operation of this embodiment is substantially the same as that according to Figs. 23 to 36.

The automatic rivet feed mechanism can also be otherwise constructed, and instead of compressed air hammers for the riveting use may be made of other riveting tools.

Thick plate can be countersunk also by means of a milling cutter instead of a profiled or shaped countersink punch.

Figs. 40 to 43 show modifications of the machine in which the countersink punch is also encompassed by a plate closer.

In the construction of Figs. 40 and 41 a pressing punch 164 having at its lower end a countersinker 165 is screwed in a support 163 of a machine for making rivet holes. Disposed around punch 164 is a plate closing sleeve 166 which is slidable relative to punch 164. Sleeve 166 engages by an inner flange 167 over an extension 168 of the punch 164. A rubber ring or collar is disposed between sleeve 166 and support 163. Punch 164 has a bore 170 in which a drill 171 is axially slidable. The table 172 of the machine is below punch 164 and is provided with a countersink 173 corresponding to the countersinker 165, and a bore 174.

In operation the support 163 is first moved downwardly, whereby the sleeve 166 is pressed more firmly on the plates 175 and 176, and the rubber ring 169 is pressed flatter and flatter as shown on Fig. 41. After the necessary plate closure and retention is established the countersinker 165 is applied on the plates and the countersink as shown on Fig. 41 is made. The countersink is terminated when the punch 164 is applied on the plate 175 (Fig. 41). After the countersink is made the drill 171 is moved downwardly, axially with respect to punch 164, whereby the rivet hole in both plates 175 and 176 is produced. On termination of the drilling all the parts are removed from the plates, which can then be further advanced to drill the next rivet hole.

In the construction of Figs. 42 and 43 the rubber ring 169 is replaced by a spiral spring 177, which generally allows a greater stroke of the plate closer 166 than the rubber ring 169. This construction is particularly suitable for producing the rivet hole in plates 175 and 176 before making the countersink. In this case the stroke of punch 164 is greater than in the construction of Figs. 40 and 41.

After establishing the plate closure the drill 171 is first moved downwardly, so that the rivet hole is made in the extended position of plates 175 and 176. This operation is shown in full lines on Fig. 43. Thereafter the support 163 with the punch is moved downwardly with respect to drill 171 into the position shown on Fig. 43 in dotted lines. The countersink is made in the plates during this operation.

Instead of the drill use may be made of other perforating tools, such as punches for example. The plate closer secures the plates against distortion during the production of the rivet holes. It is impossible for the plates to bulge during the countersinking.

Figs. 44 to 48 show another embodiment of the riveting machine in which, as in that of Figs. 1 to 22, the raising and lowering drill head remains in the axis of the drill hole, and an automatic rivet feed and a counter-support are disposed at both sides of the drill head. In the embodiment of Figs. 44 to 48, however, the automatic rivet feeder and the counter-support are not adapted to swing or rock, but are slidably mounted with respect to the drill head.

The drill column 179 is vertically slidable in the standard 178 (Fig. 44) of the machine, this vertical movement of the drill column 179 being provided by means of a rack (not shown) which corresponds to rack 12 of Fig. 2. The drilling spindle 180, driven in known manner, is rotatable in column 179, and the drill 181 and the sinker 182 (Fig. 46) constructed as a miller, are attached to the lower end of spindle 180. Vertically slidable on column 179 is the sleeve-shaped drill head 183, but is not rotatable thereon. At the lower end of the drill head 183 the upper plate closing sleeve 184 is attached concentric with the drill 181. A sleeve-like guide 185 for a bolt 186 is provided laterally on the drill head. The outer end of sleeve 185 is provided with a closure cap 187.

The bolt 186 engages inwardly ordinarily in a recess 188 (Fig. 45) of the column 179. The outer end of the bolt 186 extends through an opening of cap 187 and is ordinarily applied on a guide bar 189, which is provided on a bracket 190 attached to the machine standard 178. The guide bar 189 is bevelled off at the lower end, at 191. In sleeve 185 there is disposed on bolt 186 a spiral spring 192 which is applied, on the one hand, against a shoulder 193 of sleeve 185, and on the other against a connection 194 of the bolt 186. In the upper position of the column 179, the spring 192 tends to press the outer end of bolt 186 against guide 189.

Disposed between the lower end of column 179 and an inner shoulder of drill head 183 is a spiral spring 195 which tends to press the drill head 183 downwardly with respect to column 179.

The cylinder 197 of the rivet feeder is disposed in oblique position on a bracket connected with the standard 178. A piston 198 is movable obliquely in cylinder 197. A guide bar 199 is provided at the upper end of piston 198, said bar being guided in a housing 200 screwed in cylinder 197. Provided at the lower end of piston 198 is a

pin 201 to which the head 202 of the rivet feeder is attached. Connected with head 202 is the end of a spiral spring 203, the other end of which is attached to a pin provided in bracket 196. The spring 203 tends to draw head 202 obliquely upwardly. A compressed air feed passage 205 is connected with cylinder 197.

Disposed in head 202 of the rivet feed, superposed, are two spring-actuated jaw pairs 206 and 207 and a horizontally movable, spring-actuated rivet-inserting punch 208. The parts 206, 207 and 208 have the same function as the parts 81, 82 and 88 in the precedingly described rivet feed head 80 of Figs. 16 to 18, and thus require no further description.

The rivet feed head 202 when in the inoperative position according to Fig. 44, is mounted adjacent an inclined rivet feed trough 209 (Fig. 48) having the same function as the feed passage 127 of Figs. 26 to 33. However, the inclined feed trough 209 is not reciprocable, like the passage 127, but stationary, and is provided on a rivet distributing device 210 attached to the machine standard and provided with brushes, and having the same function as the apparatus provided with brushes according to Fig. 23. The descent of the individual rivets 211 in the trough 209 is controlled by a spring-actuated slide 212 (Fig. 47), having the same function as the slide 143 of Figs. 26 to 28.

The cylinder 213 of the counter-support 214 is disposed obliquely on the previously mentioned bracket 190 attached on the standard 178. Movable in cylinder 213 is a piston 215 on the rod 216 of which, the counter-support 214 is attached. Provided on bracket 190 is also a guide 217 on which the counter-support 214 is obliquely guided. One end of a spiral spring 218 is attached to the counter-support 214, the other end being connected with a pin connected with cylinder 213. Spring 218 tends to draw the counter-support obliquely upwardly. A compressed air feed conduit 219 is connected with the cylinder 213 of the counter-support.

The riveting hammer 18 and the lower plate closer 19 are disposed below the counter-support 214, the drill head 183 and the rivet feed head 202. The arrangement of the parts 18 and 19 corresponds substantially to the arrangement of these parts on Figs. 9 to 12 and thus need not be described.

The plates 5 and 6 to be riveted are retained on a (not shown) slide which corresponds to the previously described slide 3 (Fig. 2) between the counter-support 214, the drill head 183 and the rivet feed head 202, on the one hand, as well as the riveting hammer 18 and the lower plate closer 19, on the other.

The compressed air feed conduits 205 and 219 (Fig. 44) which are co-ordinated with the rivet feeder 197, 198, 202 and the counter-support 214, and the compressed air feed conduits 19b, 33, 35, which are co-ordinated with the riveting hammer 18 and the lower plate closer 19, are connected with a (not shown) compressed air distributor of a construction similar to that (9a, 22) of Figs. 2, 5 and 6.

The operation of the construction of Figs. 44 to 48, is as follows:

In the inoperative position the parts assume the position shown on Fig. 44. The slide 212 is first moved to the left, so that this slide, as explained in detail in connection with the operation of slide 143 of Figs. 26-28, permits the passage of a rivet 211 in the trough 209 to the upper jaw pair 206.

The drill column 179 is then lowered and, as described in connection with the construction 75

shown on Figs. 1 to 22 or Figs. 23 to 43, the rivet hole is drilled and sunk or milled in the plates 5 and 6 by means of the drill 181 and the miller 182 (see Fig. 45). Simultaneously with the lowering of column 179 the lower plate closer 19 is raised, as explained in connection with Fig. 11. In the descent of the column 179 the bolt 186 slides past on the bevel 191. As a result the spring 192 forces bolt 186 outwardly, so that the bolt comes out of engagement with the recess 188 of the column 179, which latter can therefore move downwardly with respect to the drill head. This relative movement takes place as soon as the upper plate closing sleeve 184 contacts with the upper plate 5. In the further descent of column 179 spring 195 is compressed and the upper plate closing sleeve 184 is pressed downwardly against plate 5, while at the same time the lower plate closer 19 is pressed upwardly against plate 6. The plates 5 and 6 are thereby firmly retained between the plate closers 19 and 184.

After the rivet hole is drilled and sunk or milled the column 179 is again moved upwardly.

Thereupon the head 202 of the riveting device, in whose upper jaw pair 206 the rivet 211 rests, is moved by means of piston 198 obliquely downwardly into a position in which the head 202 is vertically below the column 179. The latter is then again, and for a lesser extent than previously, moved downwardly, that is, to such an extent that the guide 189 holds the bolt 186 engaged with the recess 188. In this manner the column 179 and the drill head 183 are firmly connected together. In the previously mentioned renewed descent of the column 179, the upper plate closure sleeve 184 exerts action against the punch 208 and forces it downwardly and by means of the punch 208, the rivet 211 is driven by the upper jaw pair 206 through the lower jaw pair 207 into the hole of the plates 5 and 6 (Fig. 46). The rivet 211 is forced perfectly into the hole of plates 5 and 6 by the mutual locking of the drill column 179 and the drill head 183 by means of the bolt 186.

After the rivet 211 has been forced into the hole the column 179 is again moved upwardly. Also, the head 202 of the riveting device is returned to the upper position of Fig. 44 by means of the spring 203.

Thereupon, by means of the piston 215, the counter-support is moved obliquely downwardly into the operative position of Fig. 47, in which the counter-support 214 is seated on the sunk head of the rivet 211 inserted in the hole. Riveting then takes place by means of the hammer 18, as described for Fig. 11.

After the riveting the counter-support is moved back to the upper position of Fig. 44 by means of the spring 218. The lower plate closer 18 is also moved to the lower position of Fig. 44. Finally, the plates 5 and 6, as described for Figs. 1-22, are advanced for a rivet hole spacing. The preceding described operations are thereupon repeated.

We claim:

1. An automatic drilling and riveting machine for fixing countersunk rivets in long plates comprising a work-table, means for clamping the work on the work-table, means for intermittently feeding forwards the table, a drill disposed above the work on said table, a countersinking tool combined with the drilling tool of said drill, a riveting hammer disposed below the table with its axis in alignment with the axis of the drill, a rivet feeding device mounted on one side of

the drill above the work, means for moving said feeding device either into a position above the hole drilled in the plates or to one side, an abutment for the riveting hammer mounted on the other side of the drill above the work, means for moving said abutment either into position on the countersunk head of the rivet inserted in the drilled hole or to one side, a plate-clamping device surrounding the hammer and means for moving the plate-clamping device upwards and downwards.

2. An automatic drilling and riveting machine for fixing countersunk rivets in long plates comprising a work-table having wheels which run on rails, means for clamping the work on the work-table, means for intermittently feeding forwards the table by a distance equal to the pitch of the rivets, a drill disposed above the work on said table, a countersinking tool combined with the drilling tool of said drill, a riveting hammer disposed below the table with its axis in alignment with the axis of the drill, an aperture in said table through which said hammer can pass, a rivet feeding device mounted on one side of the drill above the work, means for moving said feeding device either into a position above the hole drilled in the plates or to one side, a counter-abutment for the riveting hammer mounted on the other side of the drill above the work, means for moving said abutment either into position on the countersunk head of the rivet inserted by the feeding device in the drilled hole or to one side, a plate-clamping device surrounding the hammer and means for moving the plate-clamping device upwards and downwards independently of the hammer.

3. An automatic drilling and riveting machine for fixing countersunk rivets in long plates comprising a work-table, means for clamping the work on the work-table, means for intermittently feeding forwards the table, a drill disposed above the work on said table, a countersinking tool combined with the drilling tool of said drill, a riveting hammer disposed below the table with its axis in alignment with the axis of the drill, a rivet feeding device mounted on one side of the drill above the work, means for moving said feeding device either into a position above the hole drilled in the plates or to one side, an abutment for the riveting hammer mounted on the other side of the drill above the work, means for moving said abutment either into position on the countersunk head of the rivet inserted in the drilled hole or to one side, a plate-clamping device surrounding the hammer, means for moving the plate-clamping device upwards and downwards, a lateral aperture in said plate-clamping device which is not closed by the hammer during the drilling operation, a second aperture in said clamping device opposite said lateral aperture and means for directing compressed air to said latter openings.

4. An automatic drilling and riveting machine for fixing countersunk rivets in long plates comprising a work-table having wheels which ran on rails, means for clamping the work on the work-table, means for intermittently feeding forwards the table by a distance equal to the pitch of the rivets, a drill disposed above the work on said table, a countersinking tool combined with the drilling tool of said drill, means for directing compressed air to the surface of the plates, a riveting hammer disposed below the table with its axis in alignment with the axis of the drill, a rivet feeding device mounted on one side of the

drill above the work, means for moving said feeding device either into a position above the hole drilled in the plates or to one side, an abutment for the riveting hammer mounted on the other side of the drill above the work, means for moving said abutment either into position on the countersunk head of the rivet inserted by the feeding device in the hole drilled in the plates or to one side, a plate-clamping device surrounding the hammer, means for moving the plate-clamping device upwards and downwards, a lateral aperture in said plate clamping device which is not closed by the hammer during the drilling operation, a second aperture in said clamping device opposite said lateral aperture and means for directing compressed air to said latter aperture.

5. Automatic drilling and riveting machine in which the work is stationary during the perforating and riveting, in which there are disposed, above the work-table, laterally of the perforating tool combined with the countersinker, an automatic rivet feeder movable over the rivet hole, as well as a counter-support movable over the rivet hole, and below the table a plate closer adapted to be raised and lowered, characterized in that on a common support movable in the direction of the rivet joint, there are mounted the perforating tool combined with the sinker, and laterally thereof the automatic rivet feeder, a riveting punch and a depresser adapted to be raised and lowered and co-operating with the plate closer during insertion of the rivet, whereby, during the formation of the rivet head, the riveting punch remains on the rivet as a counter support.

6. Machine according to claim 5, characterized in that the rivet feed passage of the automatic rivet feeder, is sub-divided into a part attached to the support of the drill and the punch, and a member raising and lowering with the said punch, and which in the raised position is connected with the part attached to the support, and that in this position a rivet in the part attached to the support is released, while this part of the passage is closed off on lowering of the rivet-inserting device.

7. Arrangement for perforating thin plates comprising a chipless counter-sinker and drill, said drill being disposed within said counter-sinker and means for beginning the operation of said drill only when said counter-sinker is seated on the plate after the countersink is formed.

8. Arrangement according to claim 5, in which the perforator is disposed in the axis of the counter-sinker.

9. Arrangement according to claim 5, in which the perforator is constructed as a drill.

10. Machine for perforating thin plate, comprising a chipless countersinker, a perforator disposed coaxially therewith, and a plate closer movable relative to said countersinker, and said closer being disposed on said countersinker.

11. Machine according to claim 5, in which the perforator is slidable axially with respect to the countersinker.

12. Machine according to claim 5 in which the plate closer is constructed as a yieldable sleeve disposed on the support of the countersinker.

13. Machine according to claim 5, in which the yieldable connection between the closer and its support consists of a rubber ring.

14. Machine according to claim 5, in which the yieldable connection between the closer and its support consists of a spiral spring.

15. Machine according to claim 1, in which the head of the rivet-inserting device and the counter-support are mounted obliquely slidably on fixed frames, so that merely by being moved they can be carried over the hole drilled in the objects.

16. Machine according to claim 1, in which the head of the rivet-inserting device and the counter-support are slidable obliquely downwardly by means of compressed air-actuated pistons against the action of a spring.

17. Machine according to claim 1, in which a fixed rivet feed trough which is so arranged with respect to the head of the rivet-inserting device so that, by means of said trough individual rivets can be fed to the head when it is in the upper position.

18. Machine according to claim 1, in which the drill column and the drill head carrying the upper plate closer are ordinarily prevented from relative axial movement by a bolt which, in the movement of the drill head into the drilling position, is adapted to be released, so that then the drill head is movable relative to the column against the action of a spring, in order to press the plate closer firmly against the object.

19. Machine according to claim 1, in which the bolt is controllable by means of a fixed guide provided with a bevel, and which is so arranged that the bolt, in the downward movement of the drill head into the drilling position, on sliding past the bevel is disengaged by means of a spring from a locking recess of the column, so that on pressure of the upper plate closer sleeve on the object the drill head can move relative to the column while tensing the spring, while on forcing in the rivet by means of the upper plate closure sleeve the column and the drill head are locked by means of the bolt.

20. A machine for perforating thin plates comprising a chipless counter-sinker, a support therefor, a perforator disposed coaxially with said counter-sinker and a plate closer movable relative to said counter-sinker and said closer being disposed on said support.

OTTO OECKL.
KARL WEINHOLD.
WILHELM PLEINES.
LEO KESSLER.