

(19) World Intellectual Property Organization
International Bureau



(43) International Publication Date
23 February 2012 (23.02.2012)

(10) International Publication Number
WO 2012/024539 A1

- (51) **International Patent Classification:**
B23D 51/01 (2006.01)
- (21) **International Application Number:**
PCT/US2011/048323
- (22) **International Filing Date:**
18 August 2011 (18.08.2011)
- (25) **Filing Language:** English
- (26) **Publication Language:** English
- (30) **Priority Data:**
61/401,814 18 August 2010 (18.08.2010) US
- (72) **Inventor; and**
- (71) **Applicant :** CUZDEY, Jacob [US/US]; 1418 Gladys Way, Aderdeen, WA 98520 (US).
- (74) **Agent:** RYLANDER & ASSOCIATES P.C.; P.O. Box 250, Vancouver, WA 98666 (US).
- (81) **Designated States** (*unless otherwise indicated, for every kind of national protection available*): AE, AG, AL, AM, AO, AT, AU, AZ, BA, BB, BG, BH, BR, BW, BY, BZ, CA, CH, CL, CN, CO, CR, CU, CZ, DE, DK, DM, DO, DZ, EC, EE, EG, ES, FI, GB, GD, GE, GH, GM, GT, HN, HR, HU, ID, IL, IN, IS, JP, KE, KG, KM, KN, KP,

KR, KZ, LA, LC, LK, LR, LS, LT, LU, LY, MA, MD, ME, MG, MK, MN, MW, MX, MY, MZ, NA, NG, NI, NO, NZ, OM, PE, PG, PH, PL, PT, QA, RO, RS, RU, SC, SD, SE, SG, SK, SL, SM, ST, SV, SY, TH, TJ, TM, TN, TR, TT, TZ, UA, UG, US, UZ, VC, VN, ZA, ZM, ZW.

(84) **Designated States** (*unless otherwise indicated, for every kind of regional protection available*): ARIPO (BW, GH, GM, KE, LR, LS, MW, MZ, NA, SD, SL, SZ, TZ, UG, ZM, ZW), Eurasian (AM, AZ, BY, KG, KZ, MD, RU, TJ, TM), European (AL, AT, BE, BG, CH, CY, CZ, DE, DK, EE, ES, FI, FR, GB, GR, HR, HU, IE, IS, IT, LT, LU, LV, MC, MK, MT, NL, NO, PL, PT, RO, RS, SE, SI, SK, SM, TR), OAPI (BF, BJ, CF, CG, CI, CM, GA, GN, GQ, GW, ML, MR, NE, SN, TD, TG).

Declarations under Rule 4.17:

— of inventorship (Rule 4.17(iv))

Published:

— with international search report (Art. 21(3))

— before the expiration of the time limit for amending the claims and to be republished in the event of receipt of amendments (Rule 48.2(h))

(54) **Title:** CONVERTIBLE ZERO CLEARANCE CIRCULAR SAW

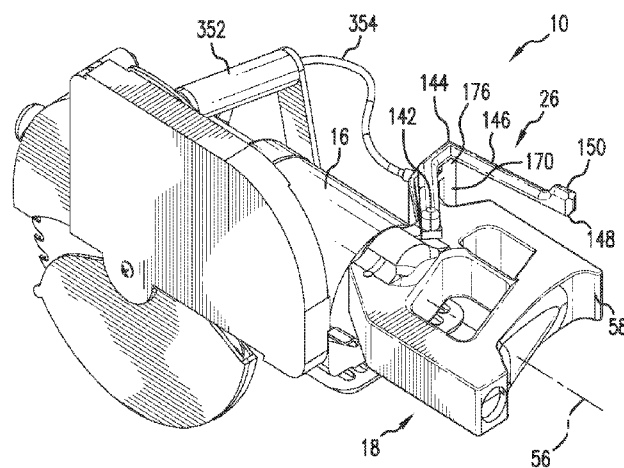
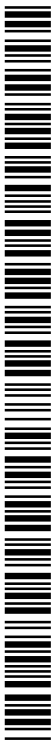

FIG. 1

(57) **Abstract:** A portable zero clearance circular saw including a motor frame portion with a transverse oriented drive shaft and arbor coupled to the drive shaft, a handle portion with, a hand grip coupled to the motor frame portion aft end, a planar blade deck on a first lateral side, a movable blade shield rotatably mounted coaxial with the drive shaft and having a sidewall with a edge face coplanar with the blade deck, a trigger proximate the hand grip to move the blade shield, and a blade couplable to the drive shaft against the arbor, such that the blade outer surface is flush with the blade deck and blade shield sidewall. The handle portion may be rotatably coupled to the motor frame portion, and may include two laterally disposed blade shield triggers operably coupled to the blade shield via a dual pulley system.



WO 2012/024539 A1

CONVERTIBLE ZERO-CLEARANCE CIRCULAR SAW

CROSS-REFERENCE TO RELATED APPLICATIONS

[0001] This application claims priority to co-pending U.S. Provisional Application Serial No. 61/401,814, filed August 18, 2010.

FIELD OF THE INVENTION

[0002] The present invention relates to portable circular saws for zero-clearance or flush cutting, such as undercut saws.

BACKGROUND

[0003] Conventional portable circular saws are not capable of safely making flush cuts – i.e. zero clearance – against a planar surface. Conventional tools mount the saw blade using attachments which project outward beyond the outside blade face, and the blade guard extends at least partially over both blade faces, and no bearing surface, or “deck”, is provided to support the saw against a first plane and the saw blade flush against a second plane. Conventional tools also use a fixed forward blade guard which is not adjustable, preventing the operator from inserting the saw by a front entry which provides superior visibility and control from “bucking”, and prevents a smooth continuous transition through different cutting directions – e.g. cutting along a floor edge and then continuously upward along a door frame or wall corner. Additionally, conventional designs do not provide effective one-handed control of the movable blade guard, so operators are either required to use one hand to operate the trigger and their other hand to operate the blade guard – placing the operator’s other hand close to the moving blade –

or they bypass the safety feature by jamming something into the guard to hold it back – also quite dangerous (but unfortunately very common).

[0004] None of the conventional tool designs provides the ability to perform all of these functions in a safe and effective manner, nor are they able to convert between conventional circular saw and a flush cutting device. Conventional single-purpose tools have other disadvantages. Generally, they are unable to make deep cuts – e.g. through a double-deck comprising two or more layers of two-inch thick stacked boards – and provide limited angular adjustment to make beveled cuts.

[0005] A number of devices have provided an ability to perform undercutting. For example, Crain Tools™ produces a conventional “undercut saw”, the model 820, capable of horizontal use to undercut along base boards and door jams. However, it is not useful for cutting vertical surfaces, lacking a deck, adjustable front guard and bevel adjustment, and is not suitable for 360° contour cutting. Additionally, jam saws lack controllable blade guards. Nor are conventional circular saws capable of conversion to a flush cutting tool. Conventional designs are (safely) capable merely of single purpose uses.

[0006] U.S. Patent No. 5,481,806, to Pratt, is for a tongue attachment to a lower blade guard of a portable electric circular saw. During a cutting operation, that tongue attachment is intended to prevent binding or snagging of the leading edge of the lower blade guard on the nearest edge of a cut, bifurcated work. The saw disclosed therein is no more capable of making a zero clearance cut than any other portable electric circular saw.

[0007] U.S. Patent No. 6,021,826 discloses a powered, chain saw cutting system for cutting mortises in a work for making mortise-and-tenon joints. Zero clearance cuts can be made with the system only in a manner that the nose end of system's saw bar and its entrained cutting chain is used to cut into a work piece in order to create a mortise therein.

The apparatus lacks a blade deck bearing surface and adjustable base deck for use on vertical and horizontal through-cuts and the retractable flush blade shield.

[0008] U.S. Patent No. 6,606,930 B2 discloses a saw cutting guide for a portable, electric, circular power saw that is intended as an aid in cutting the of the excess ends of roof shingles and the like. The disclosed saw cutting guide does nothing to permit a portable, circular power saw to achieve a zero clearance cut, and nothing in the disclosure would assist a person of ordinary skill to arrive at Applicant's invention. U.S. Patent Pub. 2004/0035274 A is similar.

[0009] U.S. Patent No. 4,245,390 discloses a scoring attachment for a portable, electric, circular saw. The attachment attaches to a front end portion of a such portable saw and imposes a score upon a surface of a wood article aligned with the rotating, circular saw blade in order to reduce or eliminate splintering of the wood during the cutting operation. The reference does not teach solutions to the need for a zero clearance saw.

[0010] U.S. Patent No. 6,568,088 B I discloses a wheel attachment for portable power cutting tools. The attachment mounts a pair of laterally spaced-apart roller wheels at a front end of portable, electric, circular power saw to reduce friction of movement of the saw over a work peice during a cutting operation. The wheels are placed all on the same side of the blade, but this is to enhance stability of the saw, not for achieving a zero clearance cut.

[0011] U.S. Patent Pub. No. US 2007/0137446 A I discloses a guide for a hand-held power tool, which can include a portable, electric, circular power saw. The guide is intended for making cross-cuts on a work. No modifications to a circular power are made or even suggested for achieving a zero clearance cut.

[0012] U.S. PatentNo. 5,121,545 discloses an improved base tilting mechanism for a portable, electric circular saw, which is said to improve stability of handling of the saw as well

as more accurate cutting. No modifications to a circular power are made or even suggested for achieving a zero clearance cut.

[0013] U.S. 7,043,845 B2 discloses a trim attachment for a portable, electric circular saw that provides a fence for cutting accurate trims of a desired thickness and substantial length from common elongated wood stock. The reference teaches only a conventional circular saw with an attachment, but does not disclose a saw capable of flush cutting.

[0014] Thus, there is a need circular saw that: (1) is portable; (2) provides zero clearance cutting capability; (3) provides continuous 360° cutting capability; (4) provides one-handed trigger and guard control using either hand; (5) is adjustable for bevel cutting; (6) provides near-instantaneous stopping of the blade; (7) can safely make deep cuts through multiple layers of lumber; (8) provide ability to convert between conventional circular saw arrangement and a zero clearance circular saw arrangement.

SUMMARY AND ADVANTAGES

[0015] A convertible zero clearance circular saw includes a motor frame portion having a motor coupled to a drive shaft; a handle portion coupled to the aft end of the motor frame portion, the handle portion including a hand grip, motor actuator on the hand grip, and one or two lower blade shield triggers proximate the hand grip to be operable by an operator's thumb; a blade deck planar bearing surface and circular cutting blade mounted to be flush with the blade deck planar bearing surface; a lower blade shield movable between a deployed position and a retracted position, disposed between the blade and motor frame portion, the blade shield including an arcuate sidewall partially circumscribing the blade cutting edge and having an edge face coplanar with the blade deck planar bearing surface; a base deck pivotable about a transverse axis and a longitudinal axis; and a front deck portion coupled to the front end of the base deck to

move between a flat deployed position and a perpendicular position. The handle may be rotatably coupled to the motor frame portion to lock at least at 0 degrees and 90 degrees. The saw may include a removable dust cover, articulated to adapted to the saw movements. The saw may include an offset blade or a flat blade with countersunk and beveled connections. The blade shield triggers may be operable independently from each other. The lower blade shield may be operably coupled to the blade shield triggers through a double pulley of dissimilar diameter sheaves. The saw may include an electromagnetic brake for near instantaneous stopping of the blade. The saw may convert to mount a standard flat blade as well.

[0016] The convertible zero clearance circular saw of the present invention presents numerous advantages, including: (1) 360 degree flush cutting against a planar surface; (2) usable as a vertical cutter or a undercut saw; (3) a remotely operated blade shield so that operators do not place their fingers near the moving blade; (4) provides greater bevel and pitch/depth adjustment than standard saws; (5) may be used as a standard circular saw or a plunge cut saw; (6) provides instantaneous braking of the blade for safety; (7) provides easy access to motor internals for maintenance; (8) independently operable blade shield triggers do not interfere with the operator's hand grip; (9) provides for ambidextrous operation; (10) allows for use of a dust cover; (11) may include a pulley-operated blade shield system which reduces wear and likelihood of binding.

[0017] Additional advantages of the invention will be set forth in part in the description which follows, and in part will be obvious from the description, or may be learned by practice of the invention. The advantages of the invention may be realized and attained by means of the instrumentalities and combinations particularly pointed out in

the appended claims. Further benefits and advantages of the embodiments of the invention will become apparent from consideration of the following detailed description given with reference to the accompanying drawings, which specify and show preferred embodiments of the present invention.

BRIEF DESCRIPTION OF THE DRAWINGS

[0018] The accompanying drawings, which are incorporated into and constitute a part of this specification, illustrate one or more embodiments of the present invention and, together with the detailed description, serve to explain the principles and implementations of the invention.

FIG. 1 shows a perspective view of a first embodiment with rotated handle portion at 90 degrees and dust cover installed.

FIG. 2 shows a perspective view of a first embodiment with handle portion at 0 degrees and dust cover installed.

FIG. 3 shows a front view of a first embodiment with 0 degrees bevel.

FIG. 4 shows a front view of a first embodiment with negative bevel.

FIG. 5 shows a front view of a first embodiment with positive bevel.

FIG. 6 shows a left side view of a first embodiment with positive pitch angle, front deck portion retracted.

FIG. 7 shows a right side view of a first embodiment with positive pitch angle, dust cover installed, front deck portion extended.

FIG. 8 shows an exploded view of a first embodiment.

FIG. 9 shows an exploded close up view of a drive shaft and blade assembly.

FIG. 10 shows a plan view of an offset blade.

FIG. 11 shows a cutaway side view of an offset blade.

FIG. 12 shows perspective view of an offset blade.

FIG. 13 shows a perspective view of a flat blade of a second embodiment.

FIG. 14 shows a cutaway side view of a blade mounting assembly.

FIG. 15 shows a cutaway front view of a flush mount blade assembly.

FIG. 16 shows a second cutaway front view of a flush mount blade assembly.

FIG. 17 shows a perspective view of a lower blade shield back side.

FIG. 18 shows perspective view of a blade deck.

FIG. 19A shows a plan view of an arbor cap.

FIG. 19B shows a side view of an arbor cap.

FIG. 20 shows a perspective view of a base deck.

FIG. 21 shows side view of a base deck.

FIG. 22 shows a side view of a second sliding connector first part.

FIG. 23 shows a plan view of a second sliding connector second part.

FIG. 24 shows a side view of a first embodiment with front deck portion retracted.

FIG. 25 shows right side view of a first embodiment with front deck portion extended and dust cover installed.

FIG. 26 shows bottom perspective view of a front deck portion.

FIG. 27 shows top perspective view of a front deck portion.

FIG. 28 shows a left side view of a first embodiment indicating lower blade shield operation.

FIG. 29 shows left side view of a first embodiment with dust cover installed.

FIG. 30 shows a perspective view of a front cover portion.

FIG. 31 shows a front view of a front cover portion.

FIG. 32 shows an internal perspective view of a blade cover portion.

FIG. 33 shows an external perspective view of a blade cover portion.

FIG. 34 shows a side view of a second embodiment.

REFERENCE NUMBERS USED IN DRAWINGS

[0019] Turning now descriptively to the drawings, in which similar reference characters denote similar elements throughout the several views, the figures illustrate the _ of the present invention. With regard to the reference numerals used, the following numbering is used throughout the various drawing figures:

10	First embodiment
12	Saw forward end
14	Saw aft end
16	Motor frame portion
18	Handle portion
20	Blade deck
22	Base deck
24	Lower blade shield
26	First lower blade shield trigger
28	Arbor
30	Motor frame portion forward end
32	Motor frame portion aft end
34	Motor
36	Drive shaft

38	Motor frame portion first lateral side
40	First transverse axis
42	Electrical cord
44	Lower blade shield axle
46	First mounting face
48	Circular saw blade
50	Blade arc
52	Blade teeth tips
54	Worm reduction gear
56	Second longitudinal axis
58	Hand grip
60	Motor actuator
62	Electromagnetic brake
64	Blade deck planar bearing surface
66	Blade offset depth
68	Base deck forward edge
70	Base deck aft edge
72	Base deck first lateral edge
74	Base deck second lateral edge
76	Base deck planar bearing surface
78	Second transverse axis
80	First longitudinal axis
82	Base deck cut-out

84	Lower blade shield journal bearing
86	Lower blade shield journal bearing frustum
88	Base deck stiffening ribs
90	Base deck back side
92	Blade shield sidewall
94	Sidewall first end
96	Sidewall second end
98	Sidewall facing edge
100	Lower blade shield front side
102	Lower blade shield back side
104	Lower blade shield internal journal bearing surface
106	Lower blade shield external sheave
108	Second cable pulley
110	Second cable pulley terminal end
112	Lower blade shield anchor block
114	Lower blade shield bias spring
116	Lower blade shield bias spring first end
118	Lower blade shield bias spring second end
120	
122	Drive shaft diameter
124	Blade shield axle exterior bearing surface
126	Blade shield axle exterior diameter
128	Blade shield axle interior bearing surface

130	Blade shield axle interior diameter
132	Arbor first part
134	Arbor first part hollow axle
136	Arbor second part
138	Arbor second part flange
140	First shield trigger first leg
142	First shield trigger first leg first end
144	First shield trigger first leg second end
146	First shield trigger second leg
148	First shield trigger second leg second end
150	First shield trigger finger tab
152	Handle portion first lateral side
154	Second lower blade shield trigger
156	Handle portion second lateral side
158	Second shield trigger first leg
160	Second shield trigger first leg first end
162	Second shield trigger first leg second end
164	Second shield trigger second leg
166	Second shield trigger second leg second end
168	Second shield trigger finger tab
170	Center lever bridge portion
172	Center lever first leg
174	Center lever second leg

176	Bridge portion first end
178	Bridge portion second end
180	Bridge portion first leg end
182	Bridge portion second leg end
184	Bridge portion first tab
186	Bridge portion second tab
188	Sixth transverse axis
190	Double pulley
192	Fifth transverse axis
194	Double pulley first sheave
196	First sheave diameter
198	Double pulley second sheave
200	Second sheave diameter
202	Center lever
204	First cable
206	First lower blade shield trigger pivot axle
208	Second lower blade shield trigger pivot axle
210	Second cable first end
212	Second cable second end
214	First cable first end
216	First cable second end
218	Blade central mounting portion
220	Central mounting portion first surface

222	Central mounting portion second surface
224	Second mounting face
226	Blade cutting portion
228	Blade cutting portion first planar surface
230	Blade cutting portion second planar surface
232	Blade cutting edge
234	Blade perimeter
236	Motor brush access port
238	Blade deck first aperture
240	Dust cover
242	Exhaust port
244	Aft cover portion
246	Lower blade cover portion
248	Front cover portion
250	Dust cover rotatable coupling connector
252	Hinge block
254	Dual axes coupler
256	Hinge block first end
258	Hinge block second end
260	Base deck hinge block longitudinal pivot coupling
262	Blade deck forward end
264	Hinge block second transverse hinge coupling
266	Dual axes hinge coupler

268	Dual axes hinge coupler first portion
270	Dual axes hinge coupler longitudinal hinge coupling
272	Dual axes hinge coupler second portion
274	Dual axes hinge coupler transverse hinge coupling
276	Fourth transverse axis
278	First sliding connector
280	First arcuate track
282	First arcuate track first end
284	First arcuate track second end
286	First closed channel
288	Stub axle
290	Stub axle base
292	Stub axle free end
294	First sliding connector first compression coupling
296	Second sliding connector
298	Second sliding connector first arcuate portion
300	Second sliding connector second arcuate portion
302	First arcuate portion first end
304	First arcuate portion second end
306	Second arcuate portion first end
308	Second arcuate portion second end
310	Second sliding connector compression coupling
312	Second closed channel

314	Blade deck interior edge
316	Blade gap
318	Blade base cutting depth
320	Blade plunge cutting depth
322	Front deck portion
324	Front deck portion forward edge
326	Front deck portion aft edge
328	Front deck portion planar bearing surface
330	Third transverse axis
332	Front deck portion locking pin
334	Front deck portion hinge joint
336	Front deck portion aperture
338	Arbor cap
340	Blade engagement projection
342	Center mounting aperture
344	Arbor cap flange
346	Arbor cap center aperture
348	Arbor cap center fastener
350	Arbor cap depth
352	Second hand grip
354	Cable sheath
356	Dust cover lower blade cover portion snap fitting
358	Dust cover lower blade cover portion sidewall

360	Dust cover lower blade cover portion sidewall edge face
362	Handle portion male locking portion
364	Motor frame portion female locking portion
1010	Second Embodiment
1028	Arbor
1360	Arbor fastener receiving holes
1362	First plurality of mounting apertures
1364	Countersunk bevels
1366	Bevel head fasteners
1368	Fastener heads
1370	Second plurality of mounting apertures
1372	Countersunk bevels

DETAILED DESCRIPTION

[0020] Before beginning a detailed description of the subject invention, mention of the following is in order. When appropriate, like reference materials and characters are used to designate identical, corresponding, or similar components in differing figure drawings. The figure drawings associated with this disclosure typically are not drawn with dimensional accuracy to scale, i.e., such drawings have been drafted with a focus on clarity of viewing and understanding rather than dimensional accuracy.

[0021] In the interest of clarity, not all of the routine features of the implementations described herein are shown and described. It will, of course, be appreciated that in the development of any such actual implementation, numerous

implementation-specific decisions must be made in order to achieve the developer's specific goals, such as compliance with application- and business-related constraints, and that these specific goals will vary from one implementation to another and from one developer to another. Moreover, it will be appreciated that such a development effort might be complex and time-consuming, but would nevertheless be a routine undertaking of engineering for those of ordinary skill in the art having the benefit of this disclosure.

[0022] Referring to Figs. 1-33, a first embodiment of a zero clearance circular saw 10 is shown, having opposed forward and aft ends 12 and 14, respectively, which define the longitudinal forward-aft direction, and including a motor frame portion 16, a handle portion 18, a blade deck 20, a base deck 22, a lower blade shield 24, and a first lower blade shield trigger 26. In this Specification, "longitudinal" refers generally to an axis or orientation parallel to the forward-aft axis of the saw 10, and "transverse" refers generally to an axis or orientation extending perpendicular to the longitudinal direction.

[0023] Motor frame portion 16 includes opposed forward and aft ends 30 and 32, respectively, a motor 34 mounted to motor frame portion 16 operably coupled to drive shaft 36 projecting from a first lateral side 38 of the motor frame portion 16, the drive shaft defining a first transverse axis 40. In the embodiment, motor 34 is connectable to a power source via electrical cord 42. Alternatively, motor 34 could be powered by batteries, fuel cells, internal combustion engine, or other power sources or combination thereof. Arbor 28 is coupled to drive shaft 36 and includes a first mounting face 46 adapted to mate to a second mounting face 224 of a circular saw blade 48. In the embodiment, arbor 28 is a separable from drive shaft 36, but may be integral to drive shaft 36 as well. The rotation of rotary blade 48 mounted to saw 10 defines a blade arc 50, equating to the perimeter traced by the teeth tips 52 of blade 48. In practice, blade

arc 50 will have a range of diameters based on the size of the saw blade 48 selected. In the embodiment motor 34 is mounted longitudinally, but could be mounted transversely as well. In the embodiment, drive shaft 36 is coupled to motor 34 through a reduction-worm gear 54, but other configurations may be used, including by way of example, a transverse engine mounting eliminating the worm gear, or a direct coupling to motor 34 without reduction gears.

[0024] Referring again to Figs 1, 2, 8 and 28, handle portion 18 is rotatably coupled to motor frame portion 16 at its aft end 32 so as to rotate about a second longitudinal axis 56. As seen in Figs. 1 and 2, handle portion 18 is lockable at a plurality of user selected rotated positions, including at least 0° and 90° relative to motor frame portion 16. An operator may simply compress handle portion male locking members 362 to disengage from motor frame portion female locking portions 364, rotate the handle portion 18 until the male locking portions 362 snap into the female locking portions 364 again at the new position, and the saw is ready. Handle portion 18 includes hand grip 58, and finger operable motor actuator 60 to selectively actuate motor 34. In this regard, 90° may refer to clockwise or counterclockwise rotation, depending on whether the saw 10 is intended primarily for right-handed or left-handed operation, so 90° refers to the direction away from the motor frame portion first lateral side 38 where the saw blade would be mounted and 0° indicates handle portion 18 is aligned with hand grip 58 oriented parallel to blade arc 50.

[0025] In the embodiment, depressing motor actuator 60 activates motor 34 at full speed and releasing motor trigger 60 activates electromagnetic brake 62 to instantly and completely stop rotation of drive shaft 36 and blade 48. In the embodiment,

electromagnetic brake 62 operates by applying DC current to the windings of motor 34, which is a permanent magnet AC motor in the embodiment, to lock the motor in place.

[0026] Blade deck 20 is rigidly coupled to motor frame portion 16 on the motor frame portion 16 first lateral side 38. Blade deck 20 includes a planar bearing surface 64 parallel to arbor first mounting face 46. The distance from first mounting face 46 to blade deck bearing surface 64 defines the blade offset depth 66. In the embodiment, motor 34 includes a first brush access port 236 on the motor frame portion first lateral side, and blade deck 20 includes a first aperture 238 aligned with the first brush access port 236 to provide access to an internal motor brush (not shown).

[0027] In the embodiment, blade deck 20 extends forward to blade deck forward end 262 so that blade deck bearing surface 64 extends forward to circumscribe a portion of blade arc 50, thereby defining a blade deck interior edge 314, the radial distance between the blade arc 50 and the blade deck interior edge 314 defining a blade gap 316 to receive at least a portion of the lower blade shield sidewall 92 in the retracted position.

[0028] Base deck 22 extends longitudinally from forward edge 68 to opposed aft edge 70 and transversely from first lateral edge 72 proximal to motor frame portion first lateral side 38 to second lateral edge 74, the base deck edges 68, 70, 72, 74 defining planar bearing surface 76. Base deck 22 is pivotally coupled to motor frame portion 16 about second transverse axis 78 and lockable at a plurality of user selectable pitch angles about second transverse axis 78 to adjust the blade base cutting depth 318 and plunge cutting depth 320. Base deck 22 is also pivotally coupled to motor frame portion 16 about first longitudinal axis 80 and lockable at a plurality of user selected bevel angles about first longitudinal axis 80. As seen in Figs. 3-5, 8 and 22-23, in the embodiment, the bevel angle is continuously adjustable within a range from approximately -10° to

approximately $+65^\circ$, where the base deck bearing surface 76 normal to the blade arc 50 defines 0° (see Fig. 3). Positive bevel angle is defined as base deck 22 pivoted toward the exposed cutting portion of blade 48 (see Fig. 5), and negative bevel angle is defined as base deck 22 pivoted away from the exposed cutting portion of blade 48 (see Fig. 4).

[0029] First lateral edge 72 is substantially parallel to the blade arc 50 and first longitudinal axis 80. In the embodiment, base deck 22 includes a cut-out 82 along its first lateral edge 72 to provide clearance around lower blade shield journal bearing portion 84 and frustum 86, as base deck 22 is pivoted about first longitudinal axis 80 to adjust the bevel angle. In the embodiment, other than cutout 82 the base deck first lateral edge 72 forms a straight edge proximate blade arc 50 and first longitudinal axis 80, and so is described as “substantially” parallel. In the embodiment, base deck 22 includes a plurality of longitudinal stiffening ribs 88 along the back side 90, the back side 90 being the opposed side from bearing surface 76.

[0030] In the embodiment, base deck 22 is coupled to motor frame portion 16 by a forward mounted hinge block 252 and aft mounted dual axes coupler 254. Hinge block 252 has a first end 256 and opposed second end 258. Hinge block first end 256 is pivotally coupled to base deck 22 by longitudinal pivot coupling 260 mounted to base deck 22 distal from base deck aft edge 70 along first longitudinal axis 80 to pivot base deck 22 around first longitudinal axis 80, thereby adjusting the bevel angle. Hinge block second end 258 is pivotally coupled to motor frame portion 16 at second transverse axis 78 to pivot base deck 22 around second transverse axis 78. In the embodiment, hinge block second end 258 is directly coupled to blade deck 20 proximal blade deck forward end 262 by transverse hinge coupling 264, and blade deck 20 is rigidly coupled to motor frame portion 16, thereby coupling hinge block second end 258 to motor frame portion 16.

Hinge block second end 258 could also be directly coupled to motor frame portion 16 – the effect is the same. Dual axes hinge coupler 266 is mounted to base deck 22 proximate base deck first lateral edge 72 distal from base deck front edge 68. Dual axes hinge coupler 266 has first portion 268 including longitudinal hinge coupling 270 aligned along the first longitudinal axis 80 to pivot base deck 22 around first longitudinal axis 80, and a second portion 272 including transverse hinge coupling 274 aligned along fourth transverse axis 276.

[0031] In the embodiment, first sliding connector 278 couples between dual axes hinge coupler 266 and motor frame portion 16 to selectively set pitch angle controlling base cutting depth and plunge cutting depth. First sliding connector 278 includes first arcuate track 280 having first end 282, second end 284, and first closed channel 286 extending from proximate first end 282 to second end 284. First end 282 is coupled to dual axes hinge coupler second portion 272. First closed channel 286 slidably receives stub axle 288 there through. Stub axle 288 extends from a base 290 connected to motor frame portion first lateral side 38 to free end 292. Stub axle 288 extends through first closed channel 286 and has first selectively releasable compression coupling 294 coupled to stub axle 288 to lockingly engage against first arcuate track 280 and motor frame portion 16.

[0032] In the embodiment, a second sliding connector 296 couples between base deck 22 and hinge block 252 to selectively set bevel angle. Second sliding connector 296 includes overlapping first and second arcuate portions 298 and 300, respectively, selectively lockingly coupled by second compression coupler 310. First arcuate portion 298 has a first end 302 coupled to hinge block 252 distal from hinge block first end 256, and a second end 304. Second arcuate portion 300 has a first end 306 coupled to base

deck 22 distal from base deck aft edge 70 and distal from base deck first lateral edge 72, and extends to a second end 308, with a second closed channel 312 extending from proximate first end 306 to second end 308. Second selectively releasable compression coupling 310 selectively lockingly engages first and second arcuate portions 298 and 300 against each other to set the bevel angle.

[0033] Compression fasteners 310 and 294 include finger levers for easy and quick loosening and tightening.

[0034] In first embodiment, a front deck portion 322 movable between a first extended position (shown in Figs. 7, 25) and a second retracted position (shown in Figs. 6, 24) is provided to permit accurate plunge cutting and the ability to cut along a 360° path around a planar surface. Front deck portion 322 has opposed forward and aft edges 324 and 326, respectively, and a planar bearing surface 328 extending there between. Front deck portion 322 is hingedly coupled proximate front deck portion aft edge 326 to base deck 22 proximate base deck front edge 68, and is pivotable about third transverse axis 330. Front deck portion 322 is lockable at least at a first position (shown in Fig. xxx), wherein front deck planar bearing surface 328 is coplanar to base deck planar bearing surface 76, and wherein front deck portion forward edge 324 extends forward of blade arc 50, and a second position (shown in Fig. xxx), wherein front deck portion planar bearing surface 328 is normal to base deck planar bearing surface 76 and facing forward. In the embodiment, front deck portion 322 includes a locking pin 332 engageable with hinge joint 334 to lock front deck portion 322 in the first or second position and a front deck aperture 336 to access the locking pin 332, the aperture 336 disposed to align with locking pin 332 when front deck portion 322 is in the second position.

[0035] Lower blade shield 24 is movable between a deployed position (see Fig. 29) and a retracted position (see Fig. 28). Lower blade 24 shield includes an arcuate laterally projected sidewall 92 circumscribing a portion of blade arc 50 from a sidewall first end 94 to a sidewall second end 96, the arcuate sidewall 92 including a facing edge 98 which is approximately coplanar with blade deck bearing surface 64. Lower blade shield 24 is rotatably coupled to blade shield axle 44, coaxial to drive shaft 36. Lower blade shield 24 is movable between a deployed position, shown in Figs. 6, 29, circumscribing a substantial portion of the projecting blade arc 50, and a retracted position, as shown in Fig. 28, circumscribing essentially no portion of the projecting blade arc 50. The projecting blade arc refers to the portion of the blade arc 50 extending distally past base deck 22 and forward of the saw motor frame portion 16, which will vary depending on the selected pitch angle. In the embodiment, lower blade shield 24 circumscribes substantially the entire bottom portion of blade arc 50 in the deployed position, such that if saw 10 with blade 48 mounted to the saw 10 were rested on the ground, the blade 48 would not contact the ground.

[0036] In the first embodiment, the cross section of the drive shaft 36 defines shaft diameter 122. Blade shield axle 44 is coaxial with and surrounds drive shaft 36, the blade shield axle 44 having an exterior bearing surface 124 defining an exterior blade shield axle diameter 126, the exterior bearing surface 124 to rotatably receive lower blade shield 24 over the blade shield axle 44. Blade shield axle 44 includes an interior bearing surface 128 defining an interior blade shield axle diameter 130 greater than the drive shaft diameter 122.

[0037] Arbor 28 includes a first part 132 having a hollow axle 134 to couple over drive shaft 36 and within shield axle interior bearing surface 128, and a second part 136

extending from the first part 132, the second part including a flange 138 having the first mounting face 46. Blade shield axle interior bearing surface 128 is adapted to rotatably receive arbor first part 132. In the first embodiment, the diameter of arbor flange 138 is greater than blade shield axle outer shaft diameter 124 to retain blade shield 24 on blade shield axle 44. Blade shield frustum 86 flares out to provide clearance for arbor 28 and arbor flange 138.

[0038] In the embodiment, an arbor cap 338 is provided to engage blade 48 to arbor 28, and thereby to drive shaft 36. Arbor cap 338 includes a blade engagement projection 340 to insert into and engage a center mounting aperture 342 through blade central mounting portion 218; a surrounding flange 344 to go against central mounting portion first surface 220; an arbor cap center aperture 346 to receive a fastener 348 there through; and, a center fastener 348 to engage blade 48 against arbor 28 through arbor cap center aperture 342. In the embodiment, center fastener 348 is a threaded bolt threading directly into the end of drive shaft 36 to compress blade central mounting portion 218 against arbor first mounting face 46 to couple blade 48 to drive shaft 36. Arbor cap 338 has a depth 350 dimensioned such that with arbor cap 338 engaged against blade 48, arbor cap 338 does not protrude past blade cutting portion first planar surface 228 to facilitate flush cuts. In the embodiment, blade engagement projection 340 is diamond shaped to engage diamond shaped blade center mounting aperture 342, but other shapes may be used.

[0039] Lower blade shield 24 includes front side 100 and opposed back side 102, journal bearing portion 84 with internal journal bearing surface 104 to go receive blade shield axle 44, and external sheave 106 surrounding journal bearing portion 84 to receive a cable. Blade shield axle 44 provides rotating bearing surface for blade shield journal

bearing 84, and receives the arbor shaft 134 into an internal journal bearing 128 (the interior bearing surface of blade shield axle 44) so as to stabilize drive shaft 36 and blade 48 during rotation.

[0040] First lower blade shield trigger 26 is operably coupled to lower blade shield 24 to move lower blade shield 24 between the normal deployed position and the retracted position. In the first embodiment, first trigger 26 is a lever arm having a first leg 140 extending from a first end 142 connected to a pivot axle 206 to a second end 144, and a second leg 146 extending from first leg second end 144 to a second end 148, with a finger tab 150 disposed at second leg second end 148. First lower blade shield trigger 26 is disposed along a first lateral side 152 of the handle portion 18 proximal to motor actuator 60 such that it may be operated by a first thumb of an operator while gripping the hand grip 58.

[0041] In the embodiment, a second lower blade shield trigger 154 is operably coupled to the lower blade shield 24 to move the lower blade shield 24 between the normal deployed position and the retracted position. Second lower blade shield trigger 154 is disposed along the opposed lateral side 156 of the handle portion 18 from the first lower blade shield trigger 26 proximal to the motor actuator 60 such that it may be operated by the opposing thumb of an operator while gripping the hand grip 58 with the opposing hand. In the embodiment, second lower blade shield trigger 154 is a lever arm having a first leg 158 extending from a first end 160 connected to a pivot axle 208 to a second end 162, and a second leg 164 extending from first leg second end 162 to a second end 166, with a finger tab 168 disposed at second leg second end 164.

[0042] In the embodiment, center lever 202 is disposed between first and second lower blade shield triggers 26 and 154, to provide independent operation. Center lever

202 includes a transversely oriented bridge portion 170, first and second legs 172 and 174, respectively, extending from opposing ends 176 and 178 of bridge portion 170 to first and second leg ends 180 and 182, respectively, and opposed first and second tabs 184 and 186, respectively, extending laterally from the bridge portion opposed ends 176 and 178, respectively, the center lever first and second legs 172 and 174 pivotably coupled at first and second leg ends 180 and 182 to the handle portion 18 coaxially to the first and second lower blade shield triggers 26 and 154 on a sixth transverse axis 188. First and second tabs 184 and 186 overlap first and second lower blade shield triggers 26 and 154, respectively, such that either first or second trigger 26 or 154 will engage against its respective tab 184 or 186 to move the center lever 202 when the respective trigger 26 or 154 is depressed. Double pulley 190 is rotatably coupled to the motor frame portion first lateral 38 side at a fifth transverse axis 192, the double pulley 190 including a first sheave 194 having a first diameter 196 and a second sheave 198 having a second diameter 200, the second diameter 200 smaller than the first diameter 196. First cable 204 operatively couples center lever 202 to first sheave 194; and, second cable 108 couples second sheave 198 to lower blade shield 24 around lower blade shield sheave 106, as described previously.

[0043] Lower blade shield triggers 26 and 154 are operably coupled to double pulley 190 by first cable 204 coupled at a first end 214 to center lever 202 and wrapped around double pulley second sheave 198 at a second end 216. Lower blade shield 24 is operatively coupled to double pulley 190 by second cable 108. Second cable 108 has a first end 210 wrapped around double pulley second sheave and a second end 212 wrapped around sheave 106, with a terminal end 110 coupled to anchor block 112. A bias spring

114 is coupled at a first end 116 to the motor frame portion 16 and at a second end 118 to blade shield 24 in order to bias lower blade shield 24 to the deployed position.

[0044] Lower blade shield triggers 26, 154 moving independently of each other allows ambidextrous use, wherein operating one trigger will not bring the other trigger down in contact with the hand. The lower blade shield 24 pulley and cable system permits locating the operating parts virtually anywhere on the saw 10, and provides the ability to use a rotatable handle portion 28, rather than the direct lever couplings common in existing devices. Dual pulley sheaves 194, 198 provide large shield movement for a small trigger movement, due to greater diameter of the inner sheave 196. Second cable 108 a distributes out of axis force substantially around the perimeter of lower blade shield journal bearing portion 84, thereby reducing trans-axial stress on the shield 24 and shaft 44, which lessens the likelihood of binding.

[0045] Referring to Figs. xxx, an offset circular saw blade 48 of a first embodiment 10 is shown. Saw blade 48 is removably mountable to a zero clearance circular saw 10 having motor 34 coupled to drive shaft 36, a blade deck 20 including planar bearing surface 64, and first mounting face 46 coupled to drive shaft 36. The distance from the first mounting face 46 to blade deck bearing surface 64 defines blade offset depth 66. Blade 48 includes central mounting portion 218 and a cutting portion 226 extending outward from central mounting portion 218. Central mounting portion 218 has opposed first and second surfaces 220 and 222, the central mounting portion second surface 222 including second mounting face 224 adapted to mate to first mounting face 46. Cutting portion 226 has opposed first and second planar surfaces 228 and 230 extending from the central mounting portion 218 to a cutting edge 232 disposed along the blade perimeter 234. In the embodiment, saw blade 48 is a unidirectional toothed saw blade so the

cutting edge 232 corresponds to the teeth 52 disposed along the perimeter. Blade perimeter 234 corresponds to or is coextensive to blade arc 50, as the rotation of cutting edge 232 defines the blade arc 50. In the embodiment, blade central mounting portion 218 is offset laterally from blade cutting portion second surface 230 and the distance from second mounting face 224 to blade cutting portion first planar surface 228 is equal to blade offset depth 46, such that blade cutting portion first planar surface 228 is coplanar to blade deck planar bearing surface 64 when mounted to saw 10.

[0046] Second hand grip 352 is provided, oriented transversely, to permit two-handed operation for increased stability. Second hand grip 352 also provides a secure routing path for first cable 204. First cable 204 runs through a protective cable sheath 354 to second hand grip 352.

[0047] Referring to Figs. xxx, a dust cover 240 of a first embodiment is shown. Dust cover 240 is removably couplable to saw 10 to substantially enclose blade arc 50 in order to contain much of the dust generated by cutting. Dust cover 240 includes exhaust port 242 to connect to a dust collection system, for example a shop vacuum cleaner or facility exhaust. In the embodiment, dust cover 240 includes an aft cover portion 244, a lower blade cover portion 246, and a front cover portion 248. Aft cover portion 244 is removably mountable to blade deck 24 by snapping over the upper and aft portion of blade deck 24 and covers a portion of blade 48 mounted to saw 10. Lower blade cover portion 246 is removably mountable to the lower blade shield 24 using snap fitting 356, with matching sidewall and edge face 358 and 360, respectively, to mate against blade shield edge face 98, and rotatably coupled to the aft cover portion 244, the rotatable coupling connector 250 coaxial with the first transverse axis 40, such that lower blade cover portion 246 moves with lower blade shield 24 between the deployed and retracted

positions. Front cover portion 248 is removably mountable to base deck 22 proximal base deck forward edge 68 and movable with base deck 22. In the embodiment, forward cover portion 248 snaps over hinge block 252 to move with hinge block 252, which in turn is coupled to and moves about second transverse axis 78 with base deck 22.

[0048] Referring to Figs. 13 and 34, a second embodiment 1010 is shown, generally similar to the first embodiment but having a handle portion 1018 rigidly coupled to the motor frame portion 1016, and providing only a first blade shield trigger 1026. In the second embodiment, a flat blade 1048 is mounted flush to blade deck planar bearing surface 1064, through a first plurality of mounting apertures 1362 having countersunk bevels on a first blade cutting portion planar surface 1228, using bevel head fasteners 1366. Blade 1048 may include a second plurality of mounting apertures 1370 having bevels on an opposed cutting portion planar surface 1230 to make blade reversible. This arrangement allows for a reversible blade. Generally, blade cutting edges have unidirectional cutting teeth, but some blades may have bidirectional cutting edges, for instance simple triangular teeth, or blades that have a thin grinding edge for a cutting edge, rather than teeth. Reversible blade may be desirable to extend blade life, or to prevent incorrect mounting (i.e. "idiot proofing").

[0049] In the second embodiment, the saw 1010 is adapted to mount a flat blade 1048 flush for zero clearance cuts. In this regard, flat blade means the blade depth 1066 is equal to the blade thickness. Arbor 1028 includes a plurality of fastener receiving holes 1360; the blade central mounting portion 1218 having a first plurality of mounting apertures 1362, the first plurality of mounting apertures 1362 countersunk 1364 on the mounting portion first surface 1222, the first plurality of mounting apertures 1362 corresponding to the fastener receiving holes 1360; and, a plurality of bevel head

fasteners 1366 to engage the blade 1048 to the arbor 1028 through the first plurality of mounting apertures 1362 and fastener receiving holes 1360, the fastener heads 1368 flush with the mounting portion second surface when fully engaged through the first plurality of mounting apertures 1362.

[0050] In the embodiment, the blade central mounting portion may also include a second plurality of mounting apertures 1370, the second plurality of mounting apertures 1370 countersunk 1372 on the mounting portion second surface, the second plurality of mounting apertures 1370 corresponding to the fastener receiving holes 1360, the plurality of fasteners 1366 engagable through the second plurality of mounting apertures 1370 to be flush with the central mounting portion second surface, such that the blade is reversible.

[0051] Using the first embodiment 10 as an example, in operation a blade 48 is mounted onto a saw 10 by fastening a center fastener 348 through the center mounting aperture 346 thread into drive shaft 36, thereby compressing blade second mounting face 224 against arbor first mounting face 46. Arbor 28 is rotatably engaged to drive shaft 36, and so rotates with the drive shaft, stabilized within lower blade shield axle 44. To make a flush cut, the operator lays the saw blade first planar surface 228 against the flat surface to be cut to, supported by coplanar with blade deck planar bearing surface 64 and blade shield sidewall edge face 98, actuates the motor using actuator 60, retracts the lower blade shield 24 by compressing first or second shield trigger 26 or 254, and drives the rotating saw blade 48 into the material. If the operator first locks forward deck portion 322 into the second position, then the operator may continue the cut through 360°. For example, the operator may cut continuously along a floor-wall interface, continuing up the far wall, along the ceiling, and back down the near wall.

[0052] Alternatively, the operator may rotate handle portion 18 by 90° to lay the blade 48 and planar bearing surface 64 horizontal for use as an undercut or “jam” saw.

[0053] Those skilled in the art will recognize that numerous modifications and changes may be made to the preferred embodiment without departing from the scope of the claimed invention. It will, of course, be understood that modifications of the invention, in its various aspects, will be apparent to those skilled in the art, some being apparent only after study, others being matters of routine mechanical, chemical and electronic design. No single feature, function or property of the preferred embodiment is essential. Other embodiments are possible, their specific designs depending upon the particular application. As such, the scope of the invention should not be limited by the particular embodiments herein described but should be defined only by the appended claims and equivalents thereof.

CLAIMS

I claim:

1. A portable, circular saw adapted to receive a flush mounted circular saw blade, the blade including a central mounting portion having opposed first and second surfaces, and a cutting portion with opposed first and second planar surfaces extending from the central mounting portion to a cutting edge disposed along the blade perimeter, the rotation of the cutting edge defining a blade arc, the saw comprising:
 - a. opposed forward and aft ends defining a longitudinal direction;
 - b. a motor frame portion having opposed forward and aft ends, the motor frame portion including:
 - i. a motor connectable to a power source, the motor mounted to the motor frame portion and operably coupled to a drive shaft, the drive shaft projecting from a first lateral side of the motor frame portion, the drive shaft defining a first transverse axis,; and,
 - ii. a blade shield axle extending transversely from the motor frame portion first lateral side coaxial with the drive shaft;
 - c. a handle portion coupled to the motor frame portion aft end, the handle portion including a hand grip and a motor actuator to selectively actuate the motor;
 - d. a blade deck rigidly coupled to the motor frame portion first lateral side, the blade deck including a planar bearing surface;
 - e. an arbor coupled to the drive shaft, the arbor including a first mounting face adapted to mate to a blade central mounting portion, the distance from the blade mounting face surface to the blade deck planar bearing surface defining a blade offset depth;
 - f. a lower blade shield movable between a deployed position and a retracted position, the lower blade shield having an arcuate laterally projected sidewall circumscribing a portion of the blade arc from a sidewall first end to a sidewall second end, the arcuate sidewall including a facing edge

- coplanar with the blade deck bearing surface, the lower blade shield rotatably coupled to the blade shield axle;
- g. a base deck extending longitudinally from a forward edge to an opposed aft edge and transversely from a first lateral edge proximal the motor frame portion first lateral side to a second lateral edge, the base deck edges defining a planar bearing surface, the base deck pivotally coupled to the motor frame portion about a second transverse axis and lockable at a plurality of user selectable pitch angles about the second transverse axis to adjust the blade cutting depth, the base deck further pivotally coupled to the motor frame about a first longitudinal axis and lockable at a plurality of user selected bevel angles about the first longitudinal axis.
2. A circular saw as in Claim 1, further comprising:
- a. the handle portion rotatably coupled to the motor frame portion aft end to rotate about a second longitudinal axis and lockable at a plurality of user selected rotated positions, the plurality of handle portion user selected rotated positions including at least 0° and 90°.
3. A circular saw as in Claims 1 or 2, further comprising:
- a. a first lower blade shield trigger operably coupled to the lower blade shield to move the lower blade shield between the normal deployed position and the retracted position;
4. A circular saw as in Claim 3, further comprising:
- a. the first lower blade shield trigger mounted to the handle portion proximal the hand grip such that it may be operated by a first thumb of an operator while gripping the hand grip with a first hand.
5. A circular saw as in Claim 4, further comprising:
- a. the first blade shield trigger mounted to the handle portion along the first lateral side of the handle portion proximal the hand grip; and,
- b. a second lower blade shield trigger operably coupled to the lower blade shield to move the lower blade shield between the normal deployed position and the retracted position, the second lower blade shield trigger disposed along the opposing lateral side of the handle portion from the first blade

shield trigger and proximal to the hand grip such that it may be operated by the thumb of an operator while gripping the hand grip with an opposed second hand.

6. A circular saw as in Claims 1 or 2, further comprising:
 - a. a circular saw blade removably couplable to the blade drive shaft, the blade including a central mounting portion having opposed first and second surfaces wherein the central mounting portion second surface comprises a second mounting face adapted to mate to the first mounting face, a cutting portion with opposed first and second planar surfaces extending from the central mounting portion to a cutting edge disposed along the blade perimeter, the rotation of the cutting edge defining the blade arc;
 - b. wherein, the distance from the second mounting face to the blade first planar surface is equal to the blade offset depth, such that the blade first planar surface is coplanar to the blade deck planar bearing surface.
7. A circular saw as in Claim 6, further comprising:
 - a. wherein the central mounting portion is offset laterally from the circular saw blade second surface.
8. A circular saw as in Claim 6, further comprising:
 - a. the arbor further including a plurality of fastener receiving holes;
 - b. the blade central mounting portion having a having a first plurality of mounting apertures, the first plurality of mounting apertures countersunk on the mounting portion first surface, the first plurality of mounting apertures aligned to the fastener receiving holes; and,
 - c. a plurality of bevel head fasteners to engage the blade to the arbor through the first plurality of mounting apertures and fastener receiving holes, the fastener heads flush with the mounting portion second surface when fully engaged through the first plurality of mounting apertures.
9. A circular saw as in Claim 8, further comprising:
 - a. the blade central mounting portion further having a second plurality of mounting apertures, the second plurality of mounting apertures countersunk on the mounting portion second surface, the second plurality

of mounting apertures aligned to the fastener receiving holes, the plurality of fasteners engagable through the second plurality of mounting apertures to be flush with the central mounting portion second surface, such that the blade is reversible.

10. A circular saw as in Claims 1 or 2, further comprising:

- a. the cross section of the drive shaft defining a shaft diameter;
- b. the blade shield axle coaxial with and surrounding drive shaft, the blade shield axle having an exterior bearing surface defining an exterior blade shield axle diameter, the exterior bearing surface to rotatably receive a lower blade shield over the blade shield axle;
- c. the blade shield axle further including an interior bearing surface defining an interior blade shield axle diameter greater than the motor shaft diameter, the blade shield axle interior bearing surface to rotatably receive an arbor first part;
- d. the arbor further comprising:
 - i. a first part comprising a hollow axle to couple over the drive shaft and within the shield axle interior bearing surface; and,
 - ii. a second part extending from the first part, the second part comprising a flange including the first mounting face.

11. A circular saw as in Claim 10, further comprising:

- a. wherein the arbor flange diameter is greater than the blade shield axle outer shaft diameter to retain the blade shield on the blade shield axle.

12. A circular saw as in Claim 10, further comprising:

- a. an arbor cap having:
 - i. a blade engagement projection to insert into and engage a center mounting aperture through a blade central mounting portion;
 - ii. a surrounding arbor cap flange to go against a blade central mounting portion first surface;
 - iii. an arbor cap center aperture to receive a fastener there through;and,

- b. a center fastener to engage a blade against the arbor through the center aperture.
13. A circular saw as in Claim 12, further comprising:
- a. the arbor cap having a depth dimensioned such that the arbor cap engaged against a blade and the arbor does not protrude past the blade cutting portion first planar surface.
14. A circular saw as in Claims 1 or 2, further comprising:
- a. a front deck portion having opposed forward and aft edges and a planar bearing surface extending there between, the front deck portion hingedly coupled proximate the front deck portion aft edge to the base deck proximate the base deck front edge and pivotable about a third transverse axis, the front deck portion lockable at least at a first position, wherein the front deck planar bearing surface is coplanar to the base deck planar bearing surface and wherein the front deck portion forward edge extends forward of the blade arc, and a second position, wherein the front deck planar bearing surface is normal to the base deck planar bearing surface and facing forward.
15. A circular saw as in Claim 14, further comprising:
- a. the front deck portion further including a locking pin to lock the front deck portion in at least the first or second position and a front deck aperture to access the locking pin, the front deck aperture disposed to align with the locking pin when the front deck portion is in the second position.
16. A circular saw as in Claims 1 or 2, further comprising
- a. wherein the blade deck bearing surface extends forward to circumscribe a portion of the blade arc, thereby defining a blade deck interior edge, the distance between the blade arc and the blade deck interior edge defining a blade gap to receive at least a portion of the lower blade shield sidewall in the retracted position.
17. A circular saw as in Claims 1 or 2, further comprising:
- a. wherein the lower blade shield is biased to the deployed position.
18. A circular saw as in Claim 5, further comprising:

- a. wherein the first and second blade shield triggers are operable independently from each other.
19. A circular saw as in Claims 1 or 2, further comprising:
- a. an electromagnetic brake to electromagnetically lock the motor windings, the brake automatically actuated when the motor trigger is released while the motor is connected to a power source.
20. A circular saw as in Claims 1 or 2, further comprising:
- a. a hinge block having a first end and opposed second end, the hinge block first end pivotally coupled to the base deck distal from the base deck aft edge along the first longitudinal axis to pivot the base deck around the first longitudinal axis, the hinge block second end pivotally coupled to the motor frame portion at a second transverse axis to pivot the base deck around the second transverse axis;
 - b. dual axes hinge coupler mounted to the base deck proximate the base deck first lateral edge distal from the base deck front edge, the dual axes hinge coupler having a first portion comprising a longitudinal hinge coupling aligned along the first longitudinal axis to pivot the base deck around the first longitudinal axis and a second portion comprising a transverse hinge coupling aligned along a fourth transverse axis;
 - c. a first sliding connector comprising an arcuate track having a first end, a second end, and a first closed channel extending from proximate the first end to the second end, the first end coupled to the dual axes hinge coupler second portion, the first closed channel to slidably receive a stub axle there through; and,
 - d. a stub axle extending from the first lateral side of the motor frame portion to a free end, the stub axle extending through the first closed channel and having a first selectively releasable compression coupling coupled to the stub axle to lockingly engage against the first arcuate track and motor frame portion.
21. A circular saw as in Claims 1 or 2, further comprising:

- a. a hinge block having a first end and opposed second end, the hinge block first end pivotally coupled to the base deck distal from the base deck aft edge first longitudinal axis to pivot the base deck around the first longitudinal axis, the hinge block second end pivotally coupled to the motor frame portion at a second transverse axis to pivot the base deck around the second transverse axis;
- b. the base deck further comprising a dual axes coupler disposed proximate the first lateral edge to couple the base deck to the motor frame portion, the dual axes coupler having a first portion comprising a longitudinal rotatable coupling aligned along the first longitudinal axis to pivot the base deck around the first longitudinal axis and a second portion comprising a transverse rotatable coupling aligned along a fourth transverse axis; and,
- c. a second sliding connector comprising overlapping first and second arcuate portions:
 - i. the first arcuate portion having a first end coupled to the hinge block distal from the hinge block first end, and a second end;
 - ii. the second arcuate portion having a first end coupled to the base deck distal from the base deck aft edge and distal from the base deck first lateral edge, a second end, and a closed channel extending from proximal the second arcuate portion first end to second arcuate portion second end; and,
 - iii. a second selectively releasable compression coupling to selectively lockingly engage the first and second arcuate portions against each other.

22. A circular saw as in Claims 1 or 2, further comprising:

- a. the bevel angle continuously adjustable within a range of approximately $+65^\circ$ to approximately -10° , wherein the base deck bearing surface oriented normal to the blade arc defines 0° .

23. A circular saw as in Claims 1 or 2, further comprising:

- a. a dust cover removably couplable to the saw to substantially enclose the blade arc.

24. A circular saw as in Claim 23, the dust cover further comprising:
- a. an aft cover portion, a lower blade cover portion, and a front cover portion;
 - b. the aft cover portion removably mountable to the blade deck and covering a portion of a mounted blade;
 - c. the blade cover portion removably mountable to the lower blade shield and rotatably coupled to the aft cover portion coaxial with the first transverse axis such that the blade cover portion moves with the lower blade shield;
 - d. the front cover portion removably mountable to the base deck proximal the base deck forward edge and movable with the base deck.
25. A circular saw as in Claims 1 or 2, further comprising:
- a. the motor further including a first brush access port on the motor frame portion first lateral side;
 - b. the blade deck further including a first aperture aligned with the first brush access port to provide access to a motor brush.
26. A circular saw as in Claim 3, further comprising:
- a. a double pulley rotatably coupled to the motor frame portion first lateral side at a fifth transverse axis, the double pulley including a first sheave having a first diameter and a second sheave having a second diameter smaller than the first diameter;
 - b. a first cable operably coupling the first lower shield trigger to the first sheave; and,
 - c. a second cable operably coupling the second sheave to the lower blade shield.
27. A circular saw as in Claim 17, further comprising:
- a. a center lever disposed between the first and second lower blade shield triggers, the center lever including a transversely oriented bridge portion, first and second legs extending from opposing ends of the bridge portion to first and second leg ends, and opposed first and second tabs extending transversely from the bridge portion opposed ends, the center lever first and second legs pivotably coupled to the handle portion coaxially to the first and second lower blade shield triggers on a sixth transverse axis, the

first and second tabs overlapping the first and second lower blade shield triggers, respectively, such that either the first or second lower blade shield trigger will engage against its respective tab to move the center lever when the respective trigger is depressed;

- b. a double pulley rotatably coupled to the motor frame portion first lateral side at a fifth transverse axis, the double pulley including a first sheave having a first diameter and a second sheave having a second diameter smaller than the first diameter;
- c. a first cable operably coupling the center lever to the first sheave; and,
- d. a second cable operably coupling the second sheave to the lower blade shield.

28. A circular saw as in Claim 26, further comprising:

- a. a biasing spring coupled between the motor frame portion and the lower blade shield to bias the lower blade shield toward the deployed position.

29. A circular saw as in Claim 27, further comprising:

- a. a biasing spring coupled between the motor frame portion and the lower blade shield to bias the lower blade shield toward the deployed position.

30. A circular saw blade removably mountable to a zero clearance circular saw having a motor coupled to a drive shaft, a blade deck including a planar bearing surface, and a first mounting face coupled to a drive shaft, the distance from the first mounting face to the blade deck bearing surface defining a blade offset depth, the saw blade comprising:

- a. a central mounting portion having opposed first and second surfaces wherein the central mounting portion second surface comprises a second mounting face adapted to mate to the first mounting face;
- b. a cutting portion having opposed first and second planar surfaces extending from the central mounting portion to a cutting edge disposed along the blade perimeter, the rotation of the cutting edge defining the blade arc;
- c. wherein, the blade central mounting portion is offset laterally from the blade cutting portion second surface and the distance from the second

mounting face to the blade cutting portion first planar surface is equal to the blade offset depth, such that the blade cutting portion first planar surface is coplanar to the blade deck planar bearing surface when mounted to the saw.

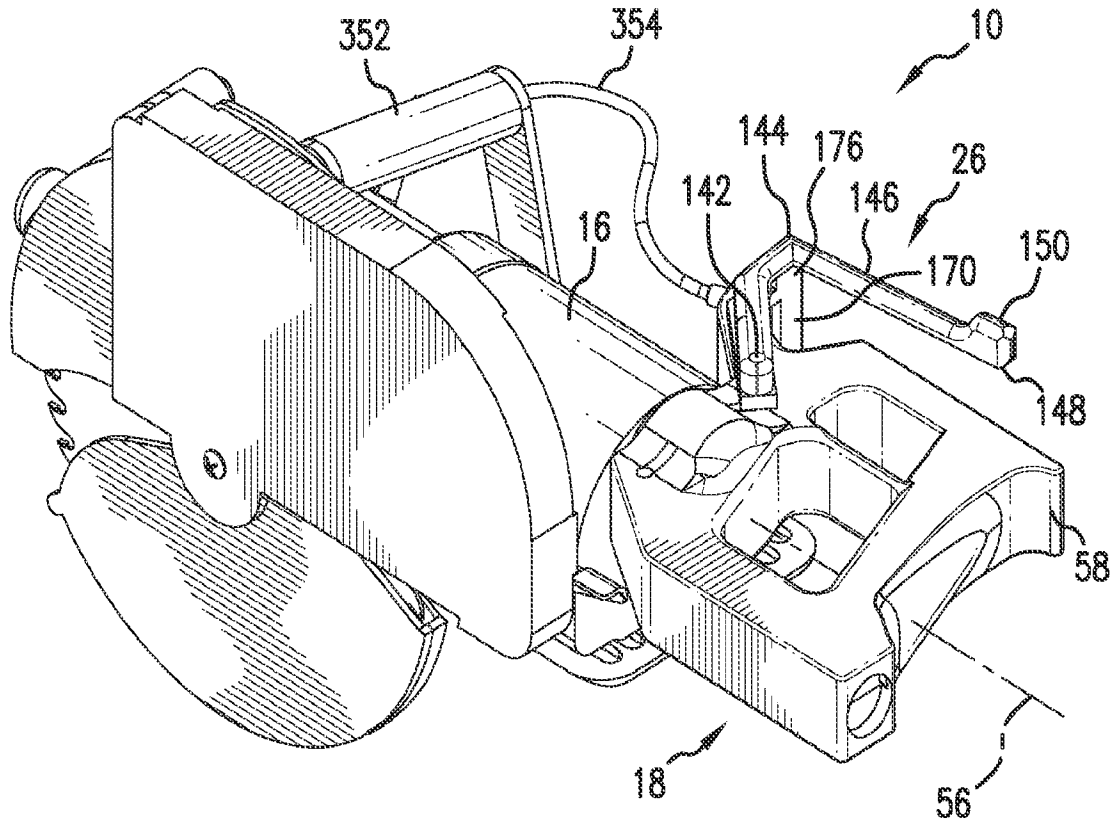

FIG. 1

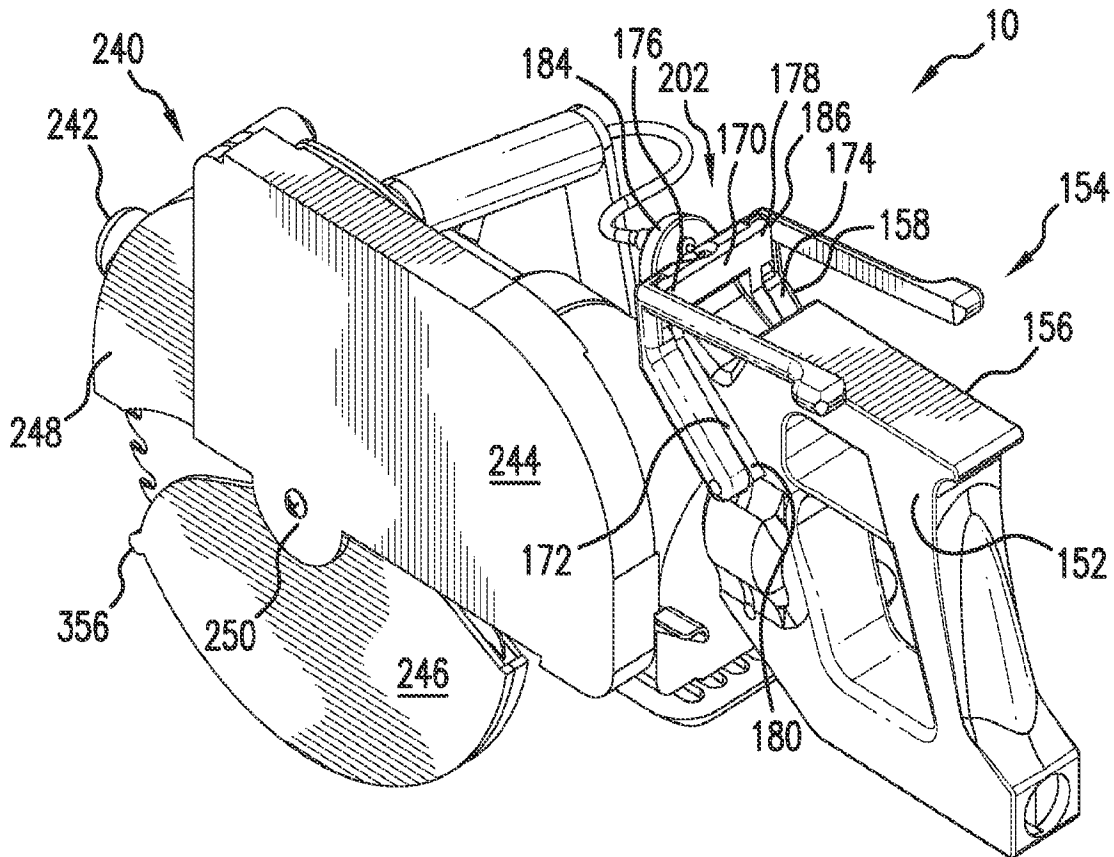

FIG. 2

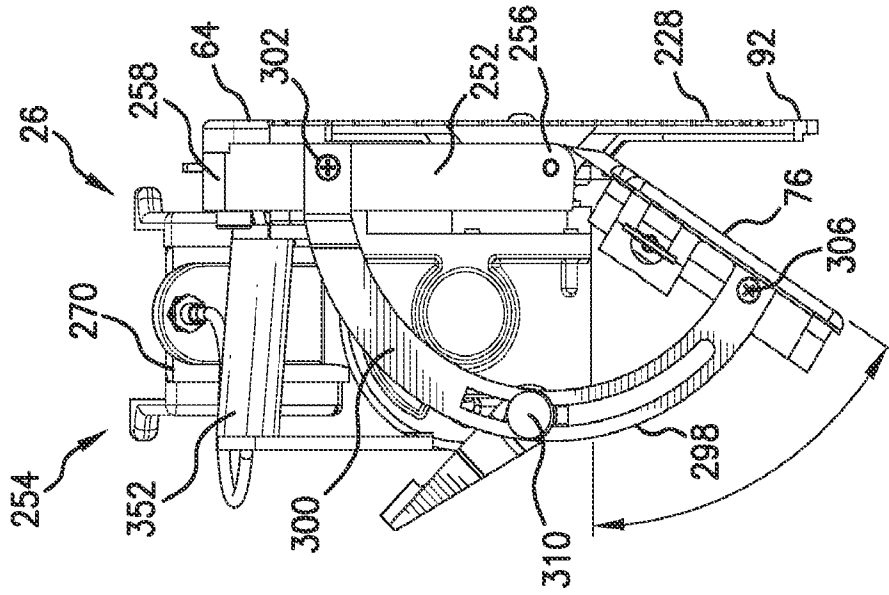

FIG. 5

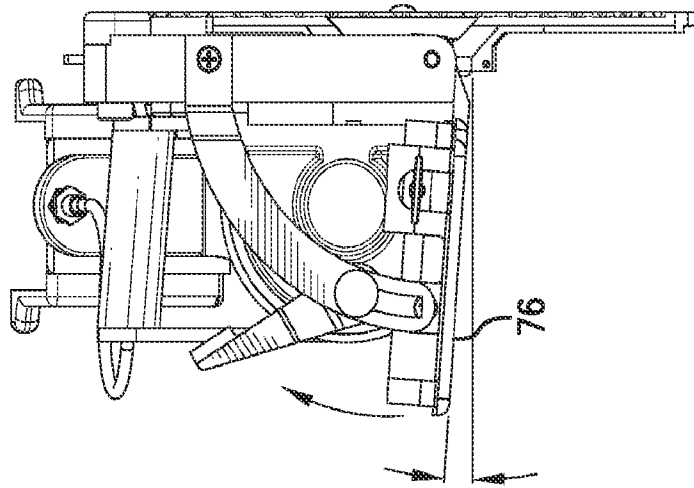

FIG. 4

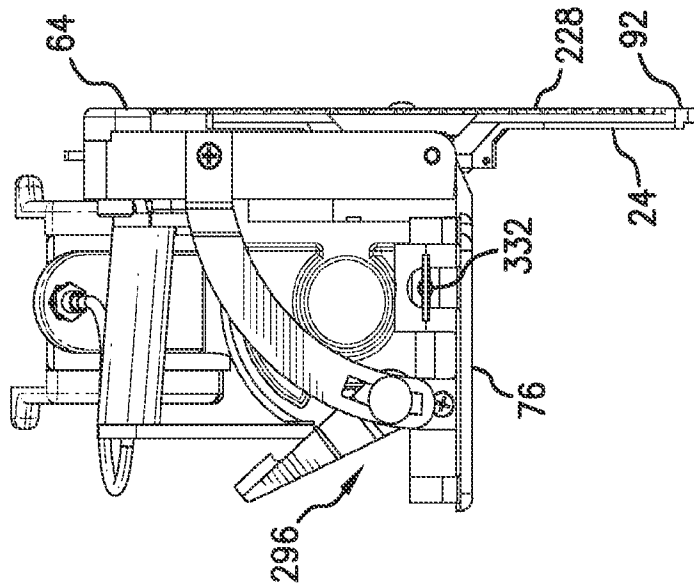

FIG. 3

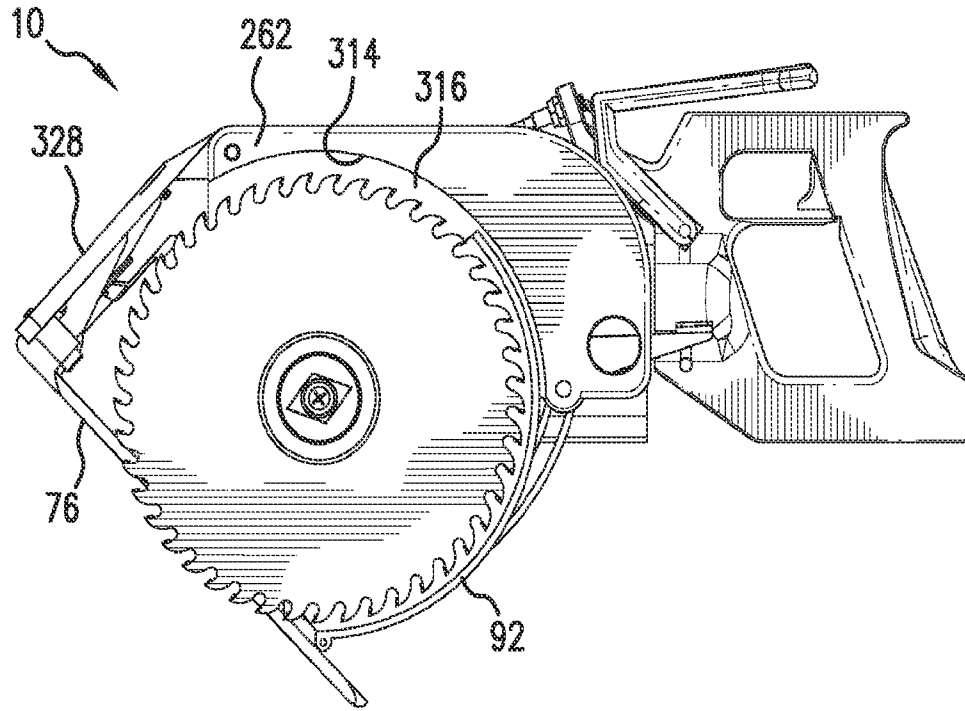

FIG. 6

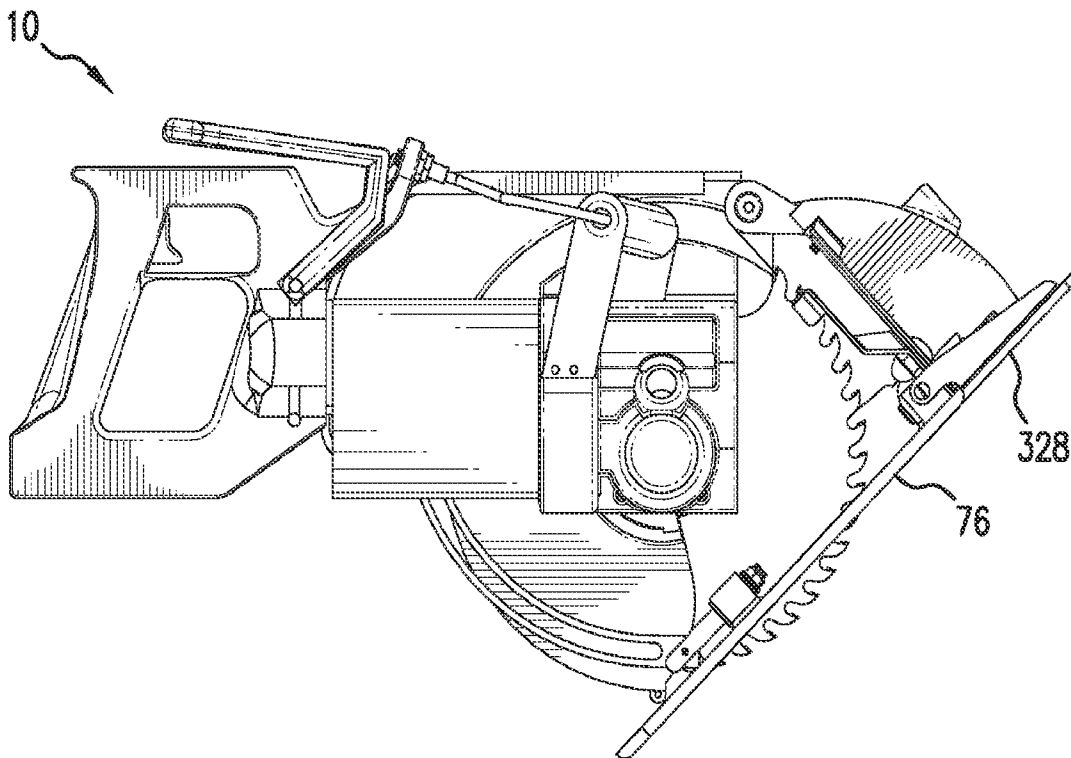

FIG. 7

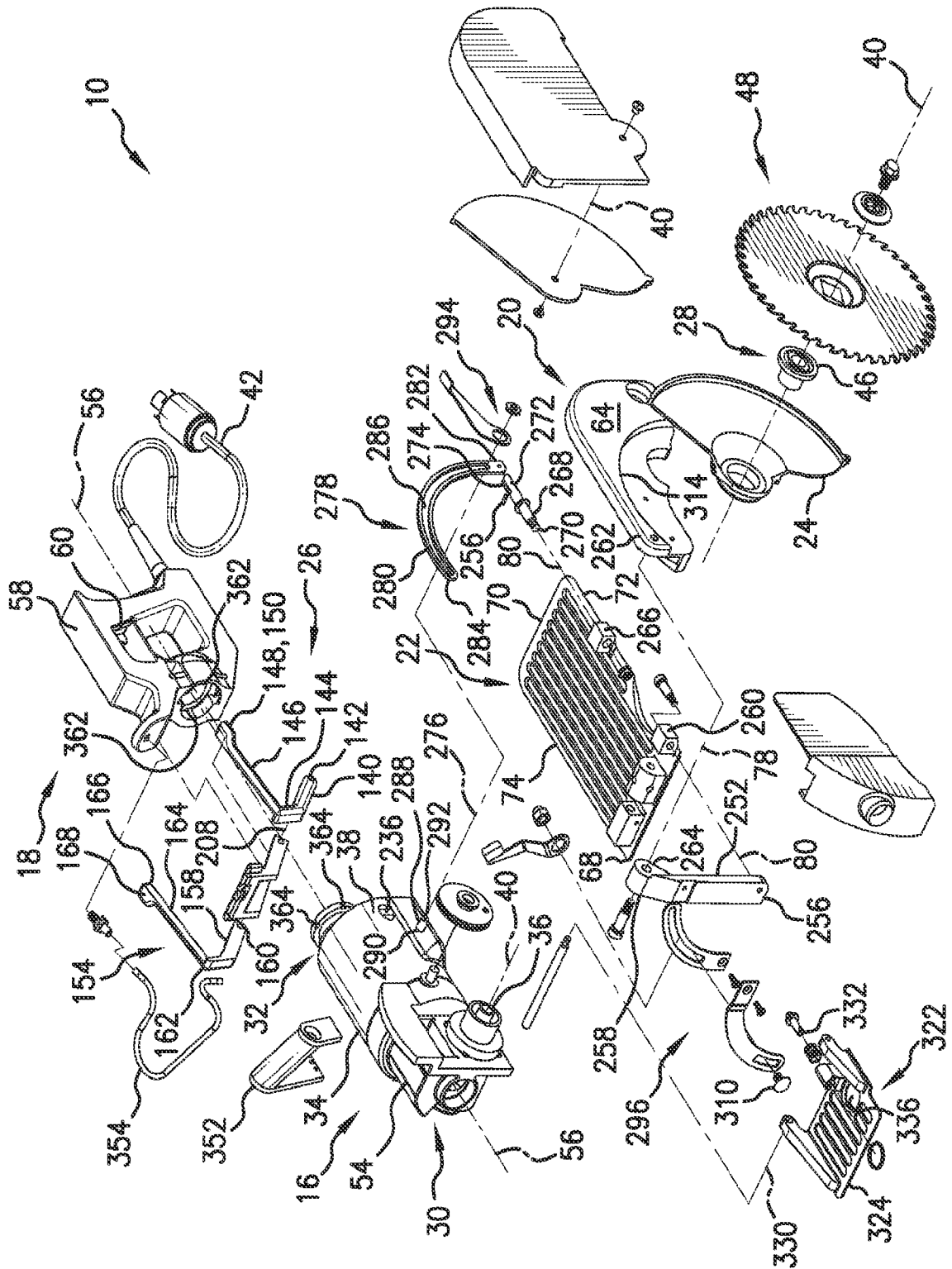

FIG. 8

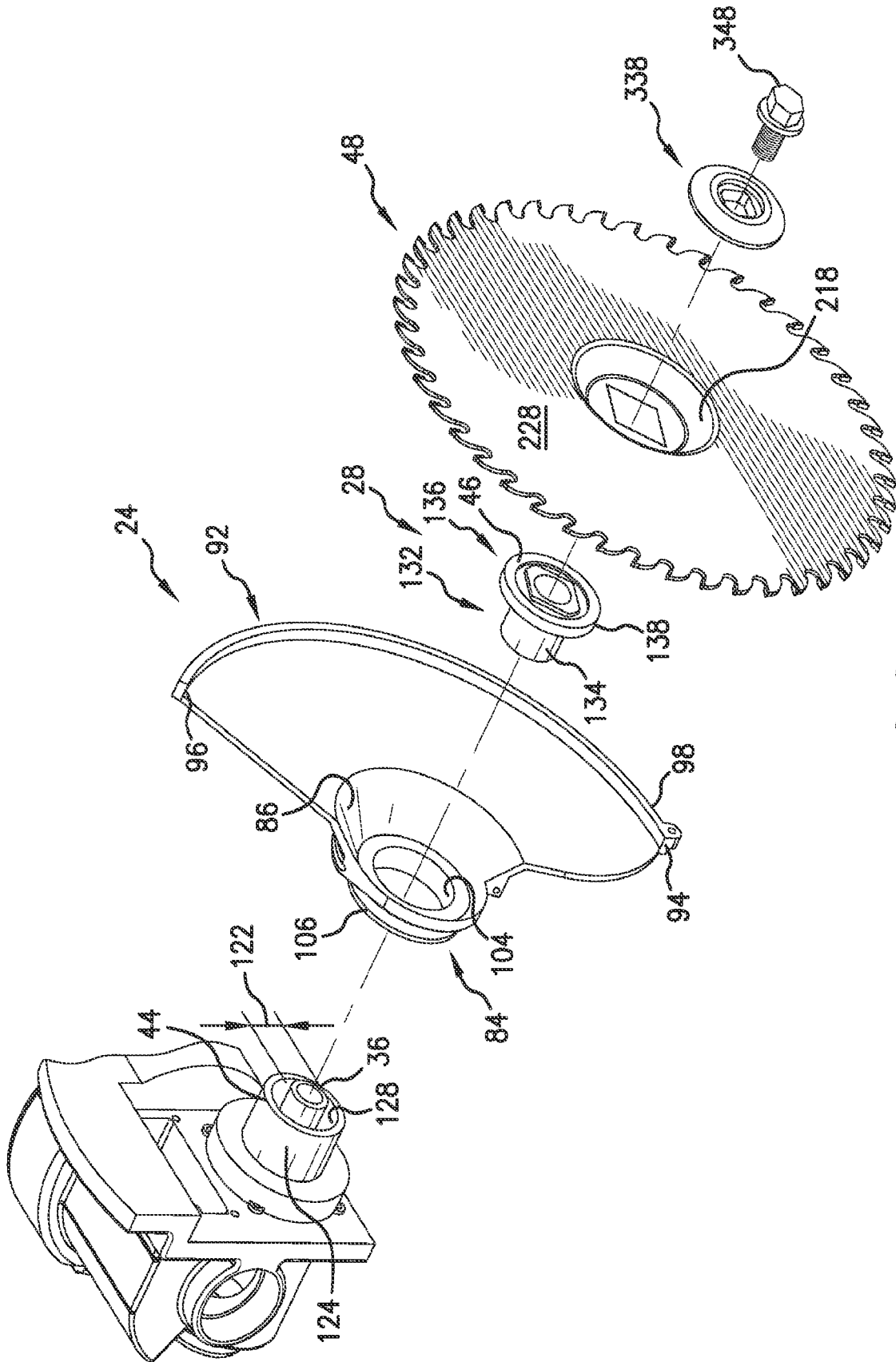

FIG. 9

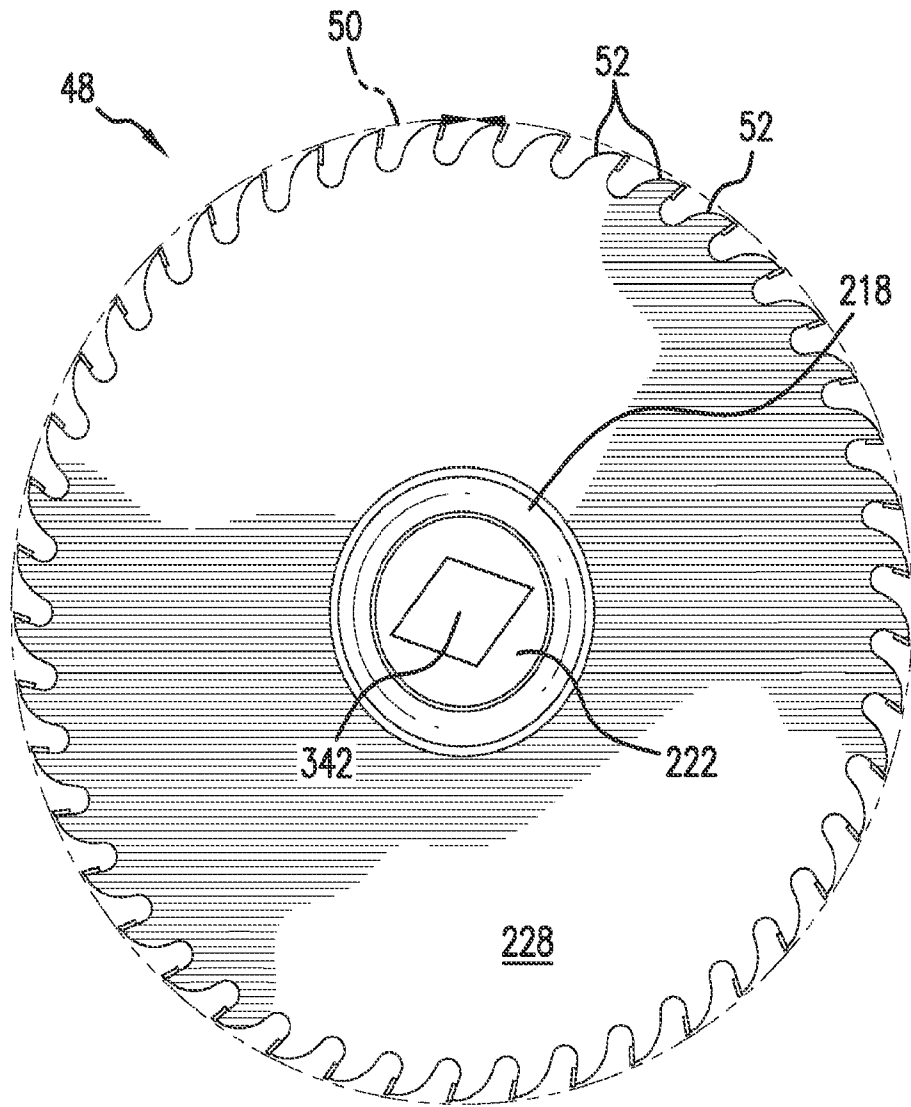

FIG. 10

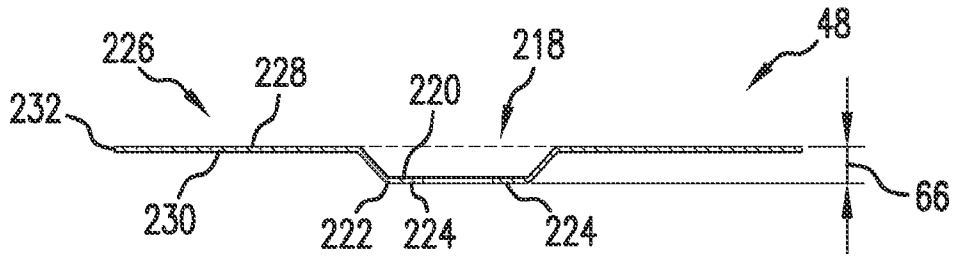

FIG. 11

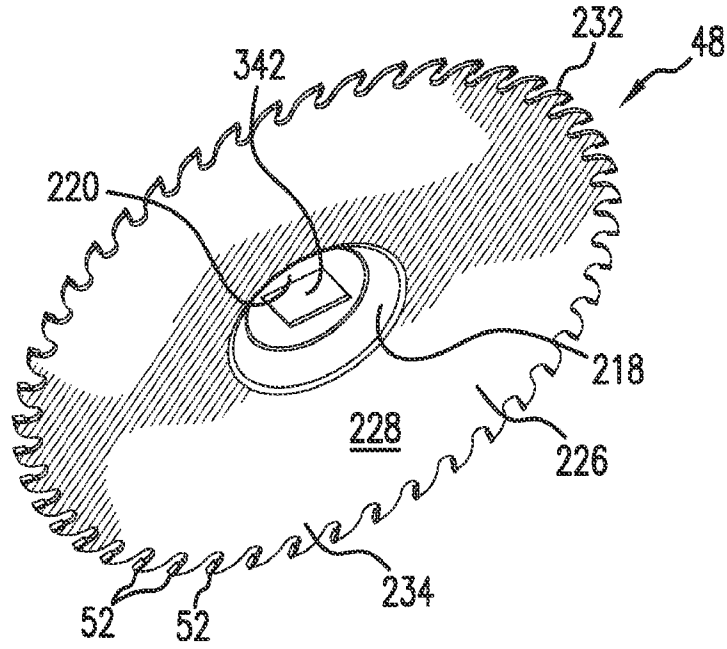

FIG. 12

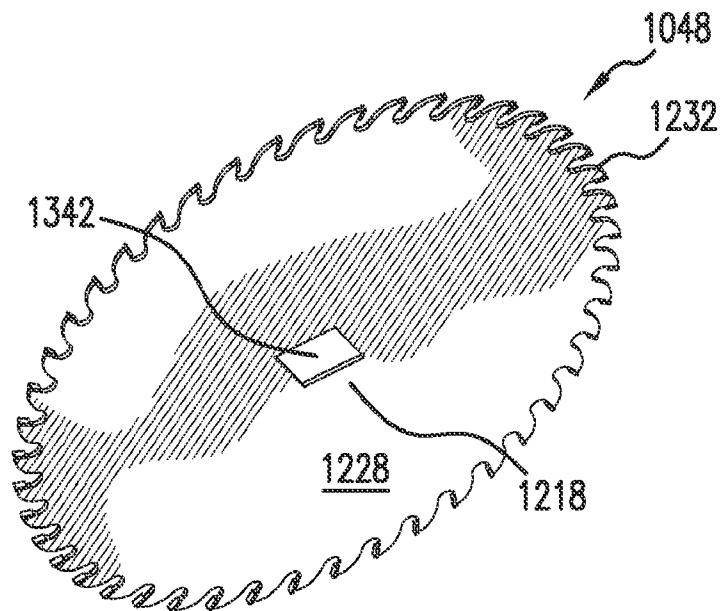

FIG. 13

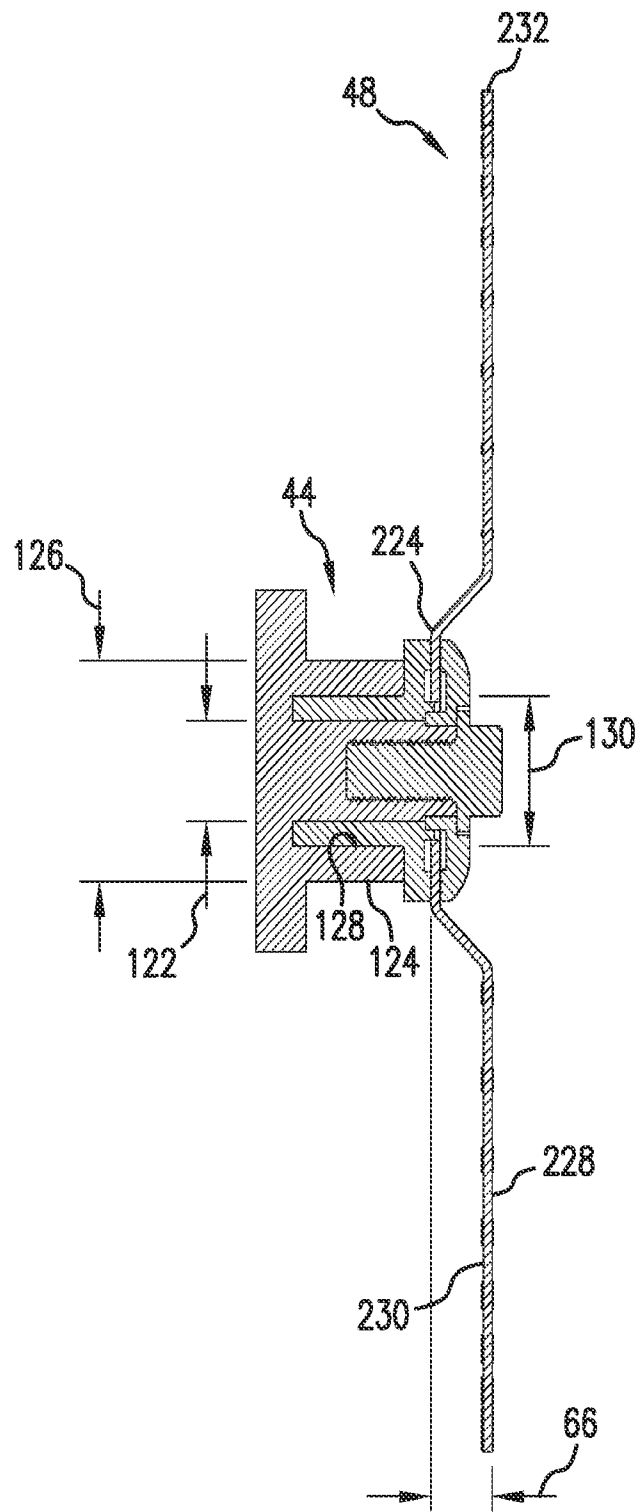

FIG. 14

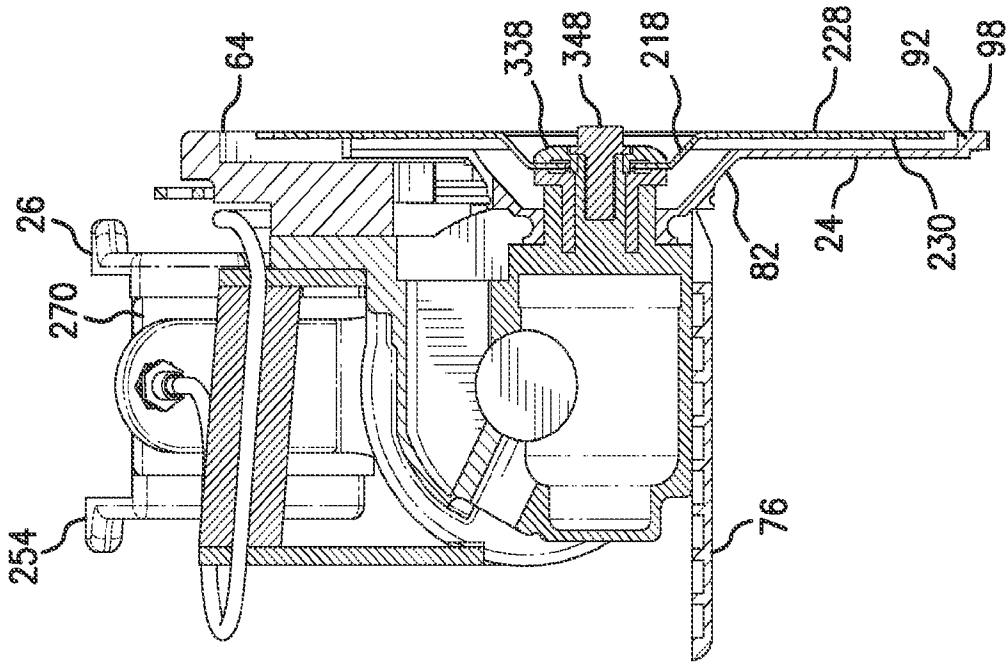

FIG. 16

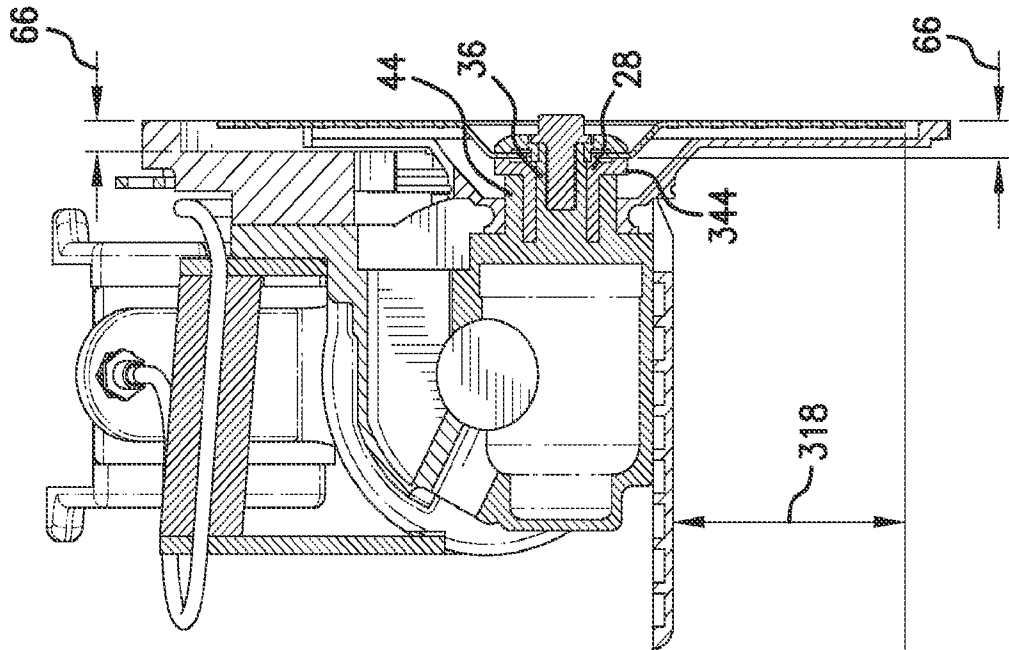

FIG. 15

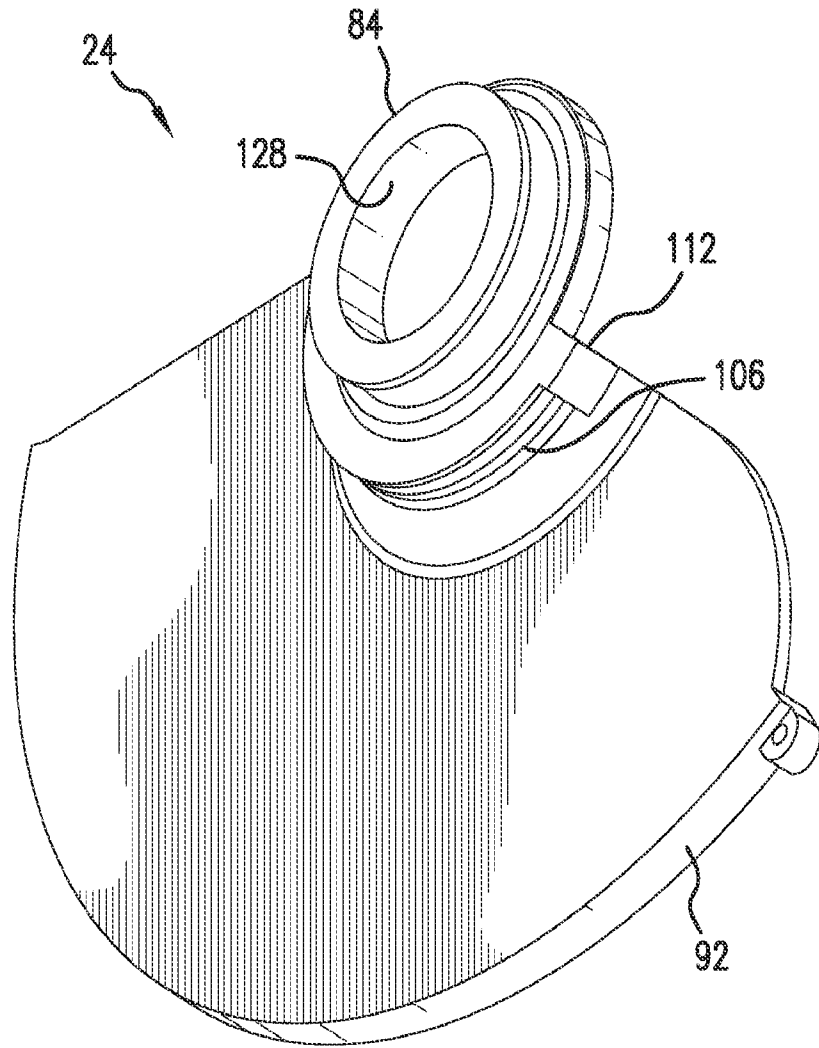

FIG. 17

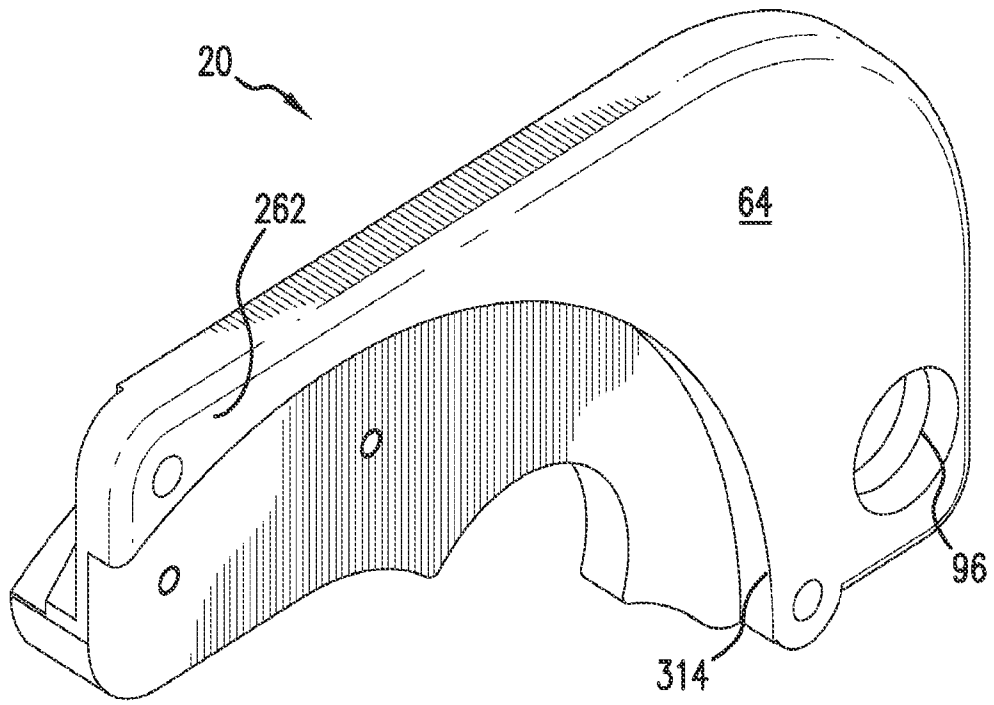

FIG. 18

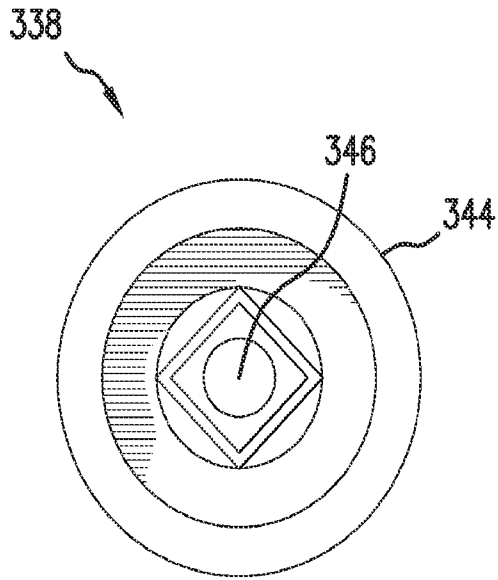

FIG. 19A

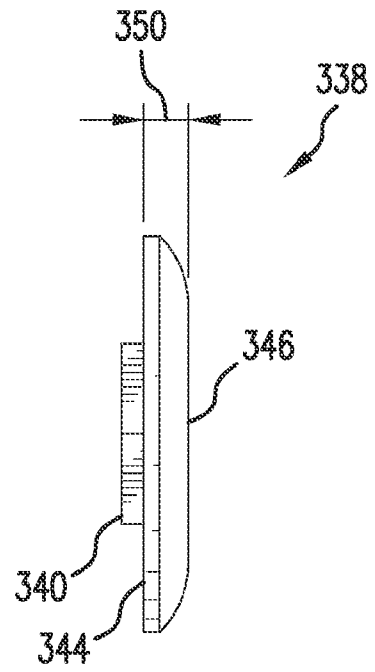

FIG. 19B

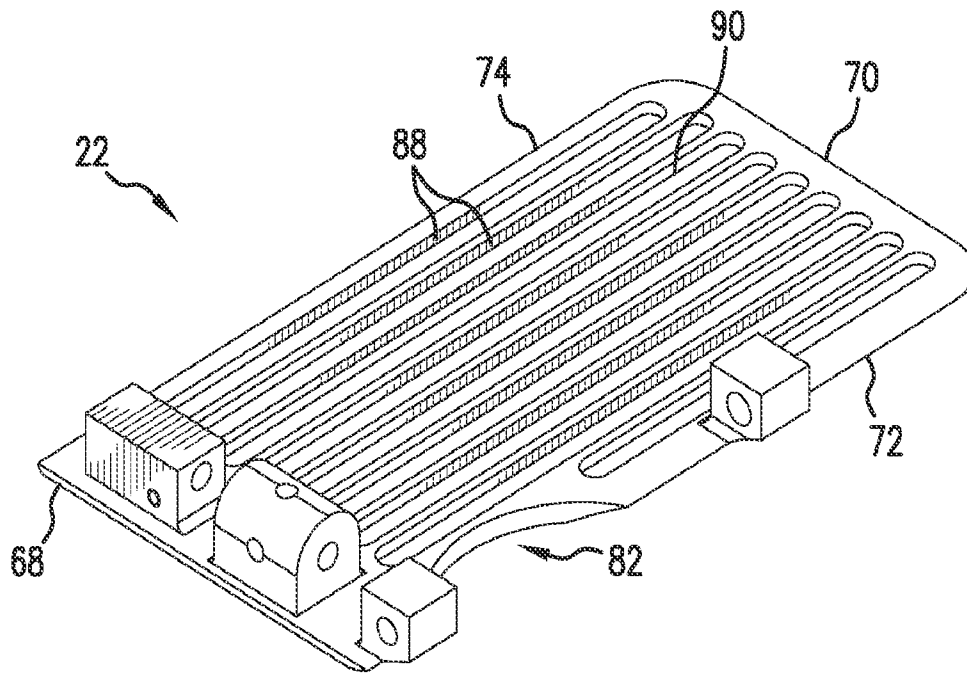

FIG. 20

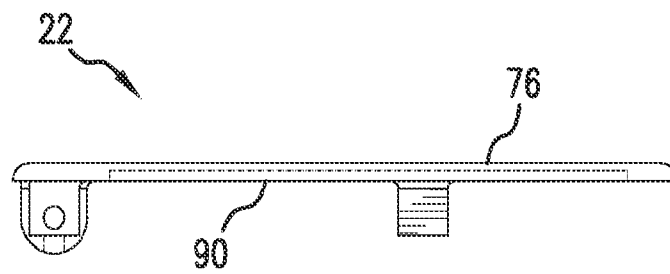
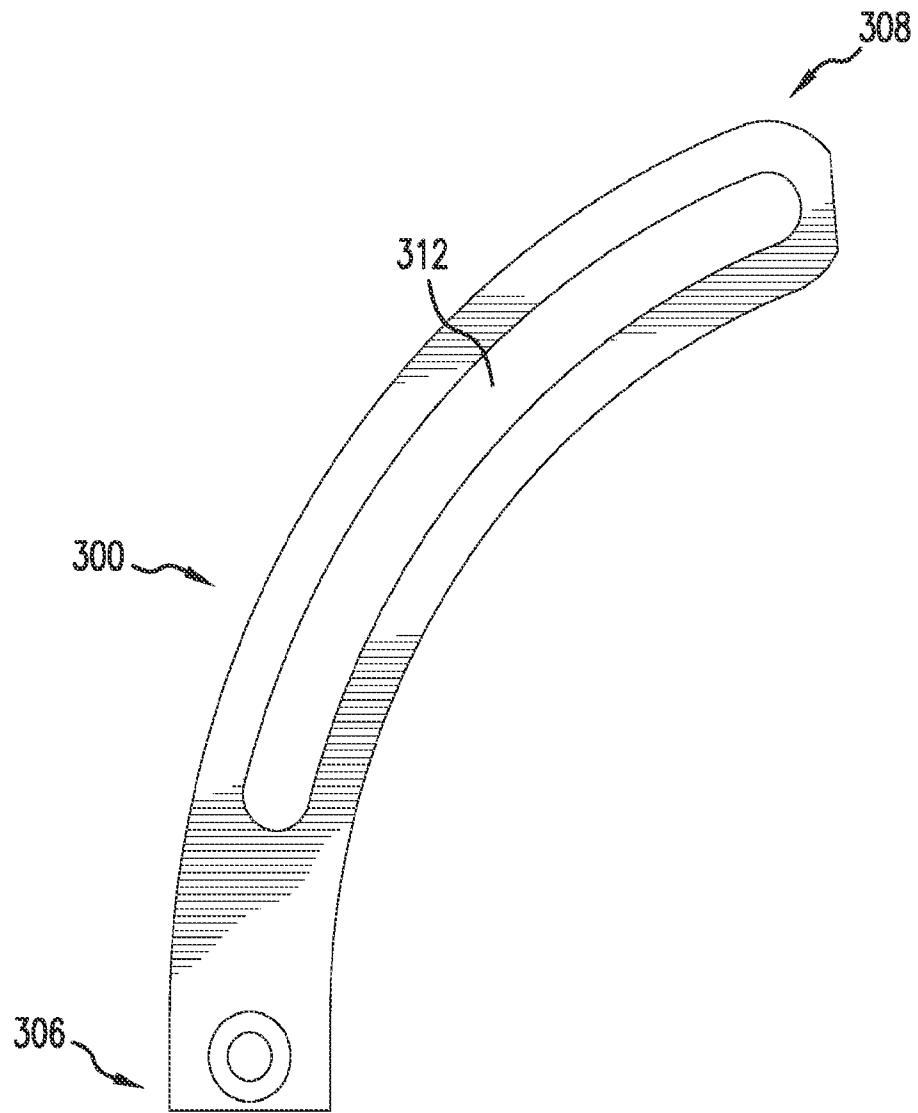
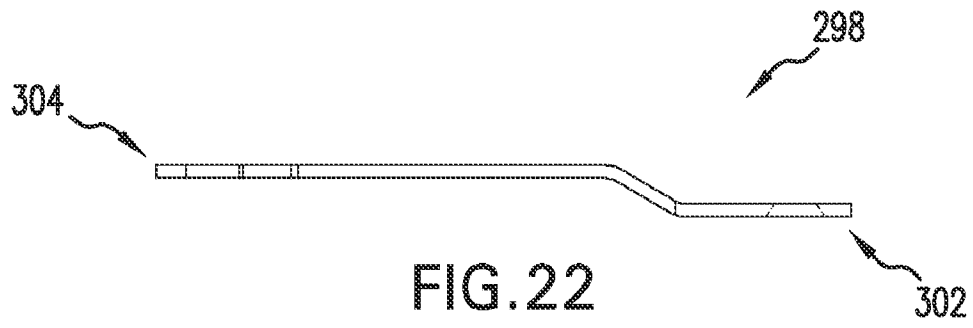

FIG. 21



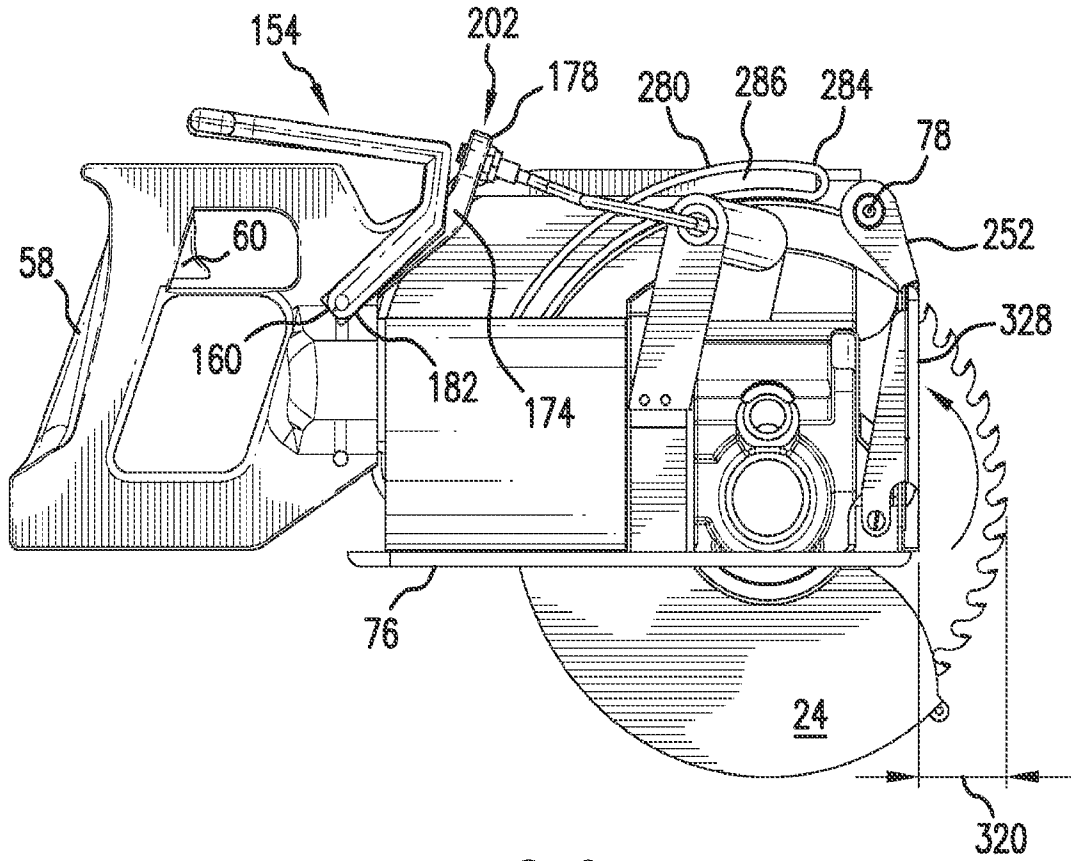

FIG. 24

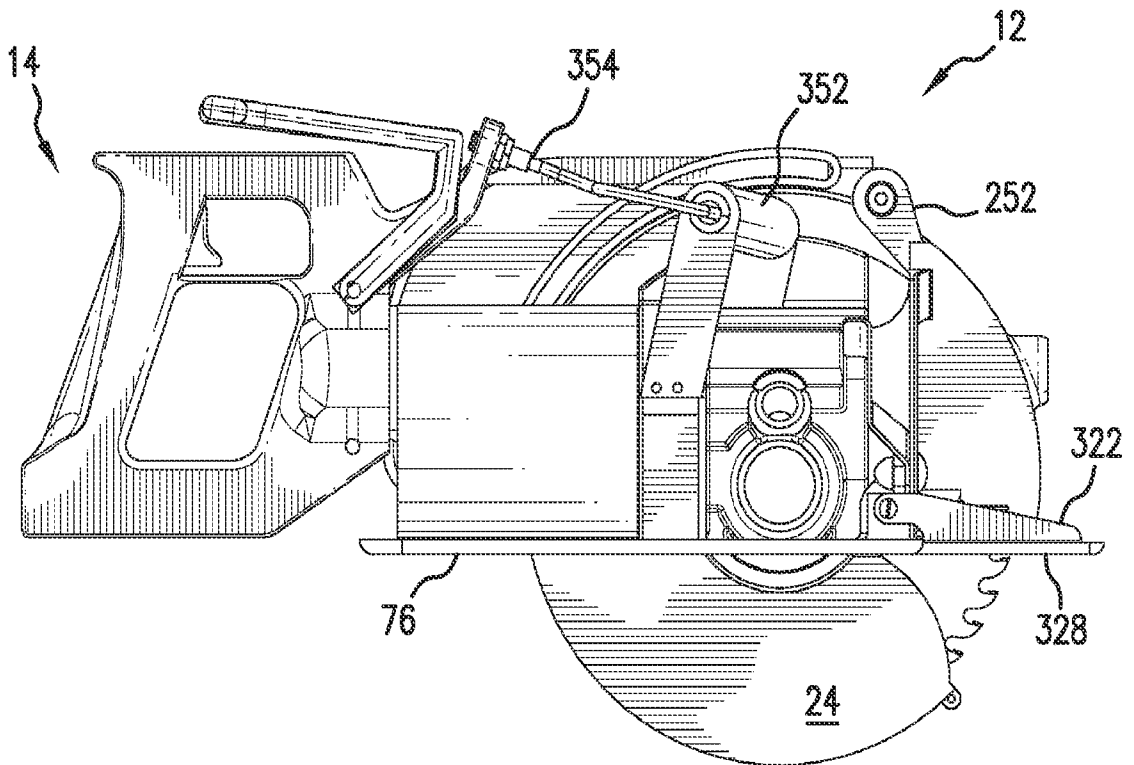

FIG. 25

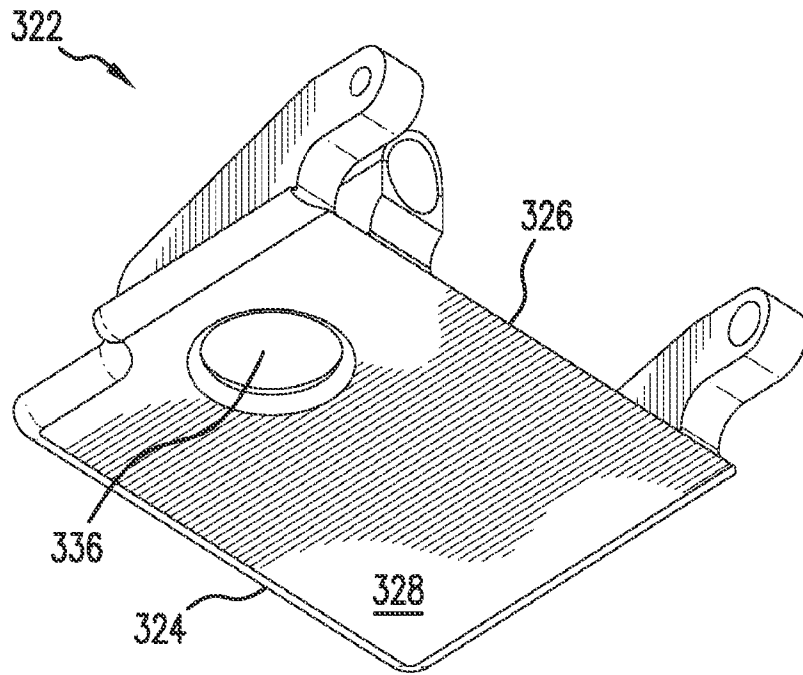

FIG. 26

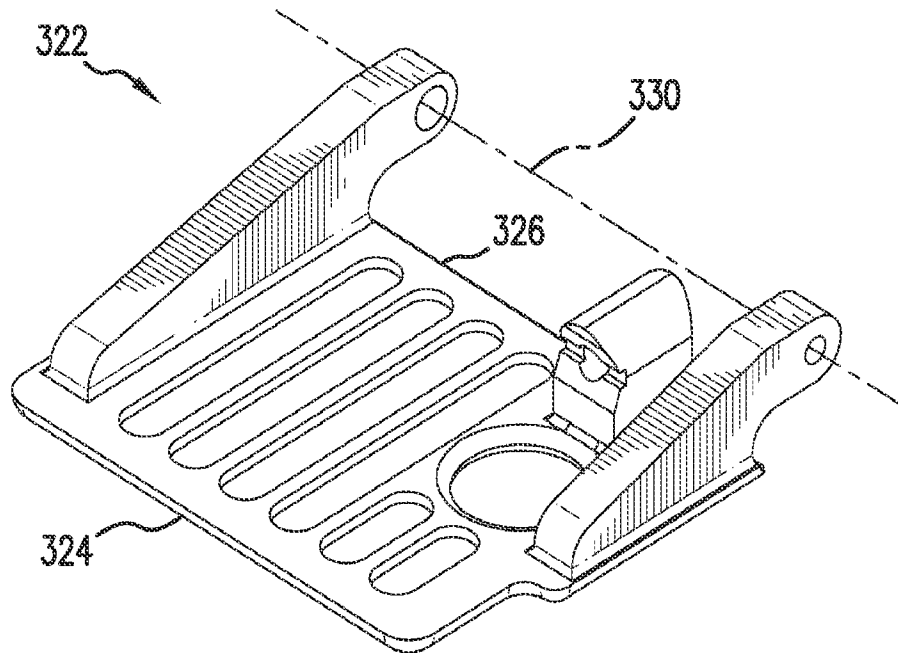

FIG. 27

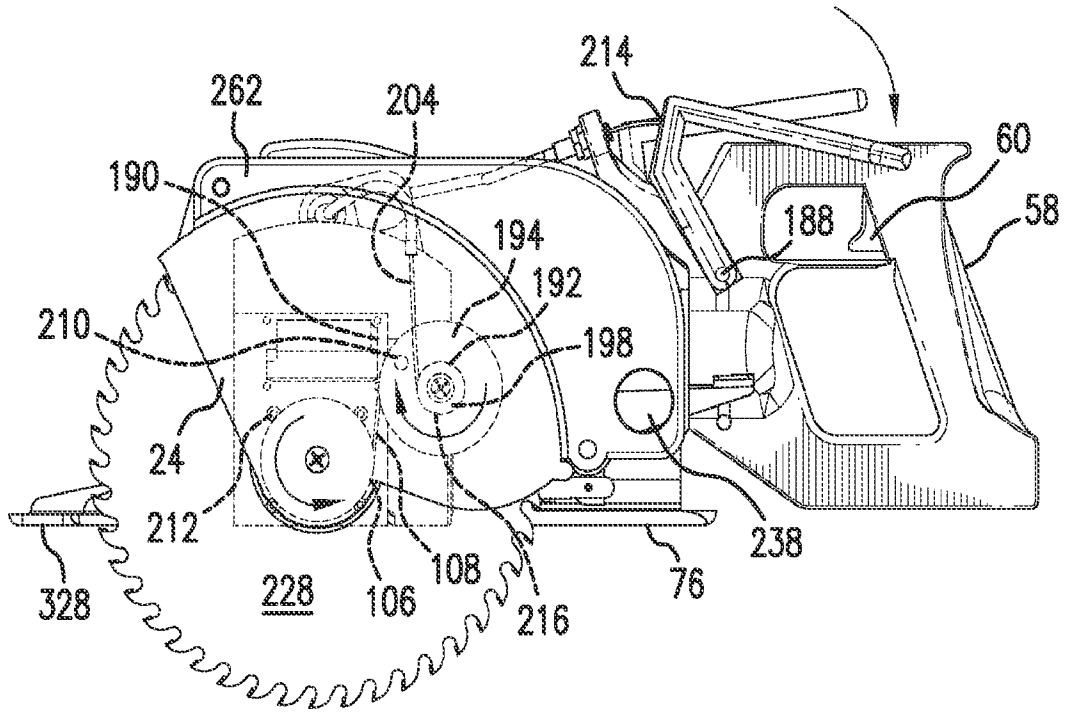

FIG. 28

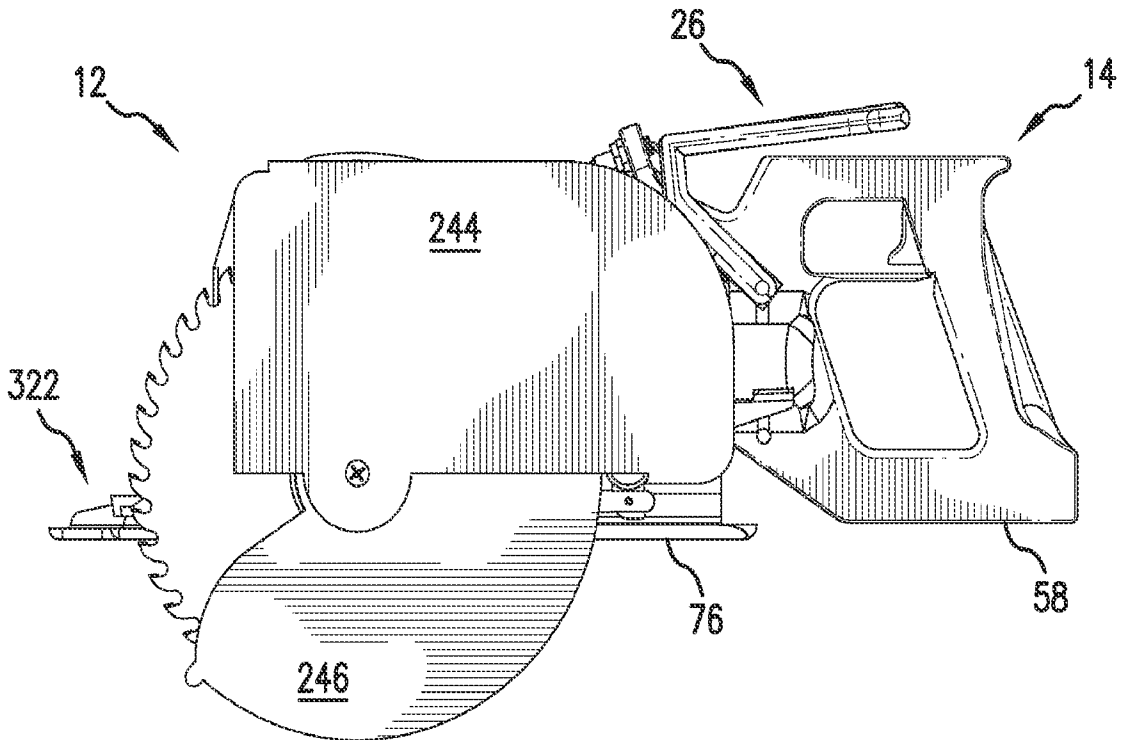

FIG. 29

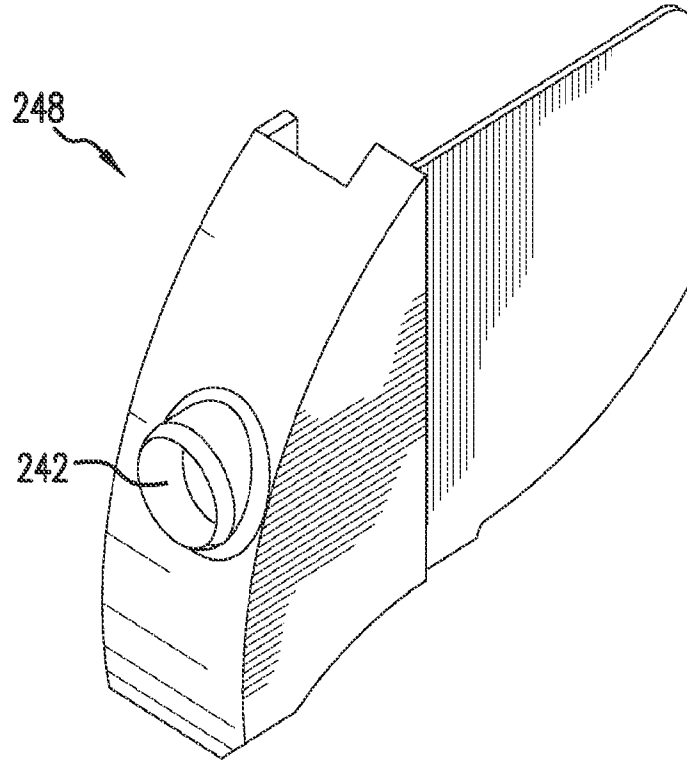

FIG. 30

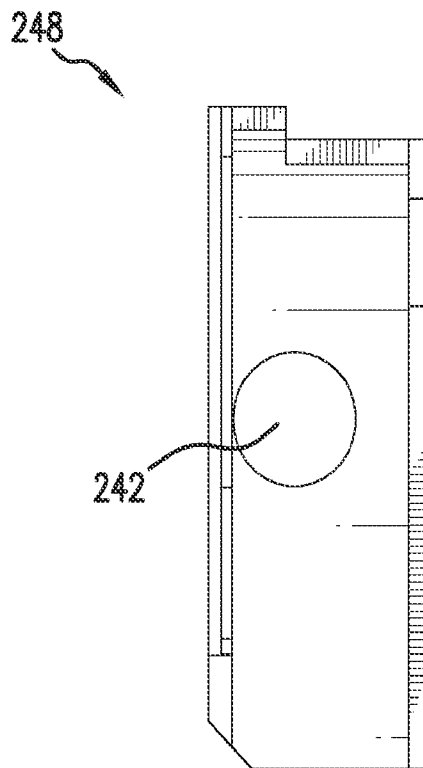

FIG. 31

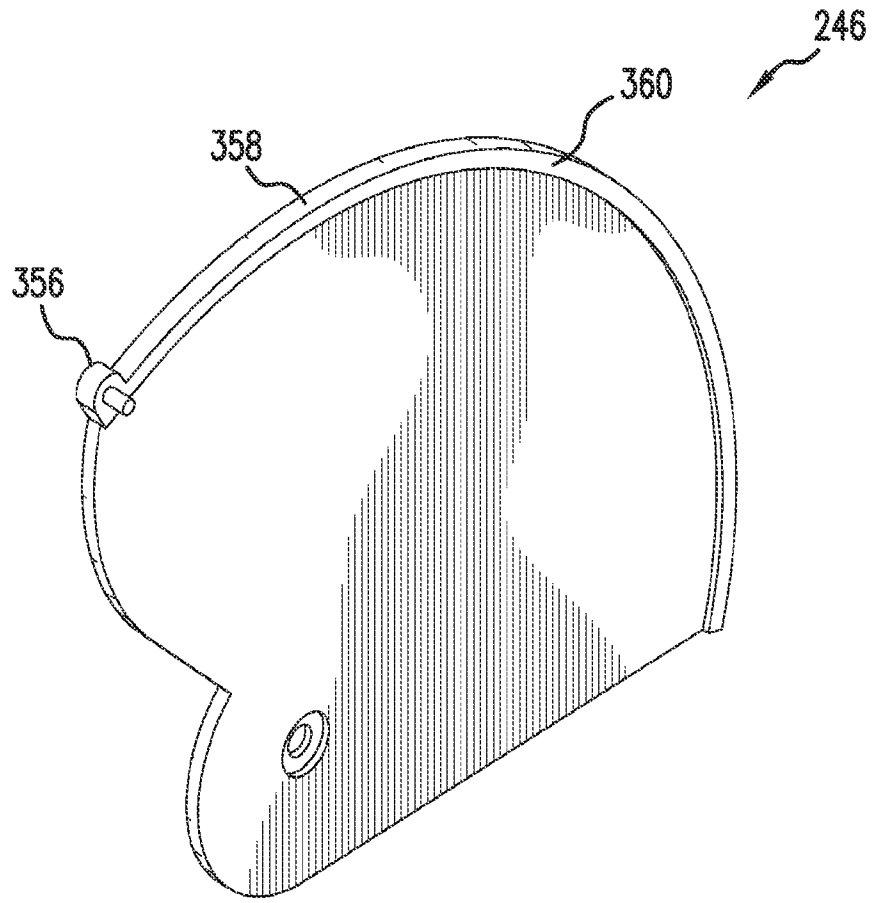

FIG. 32

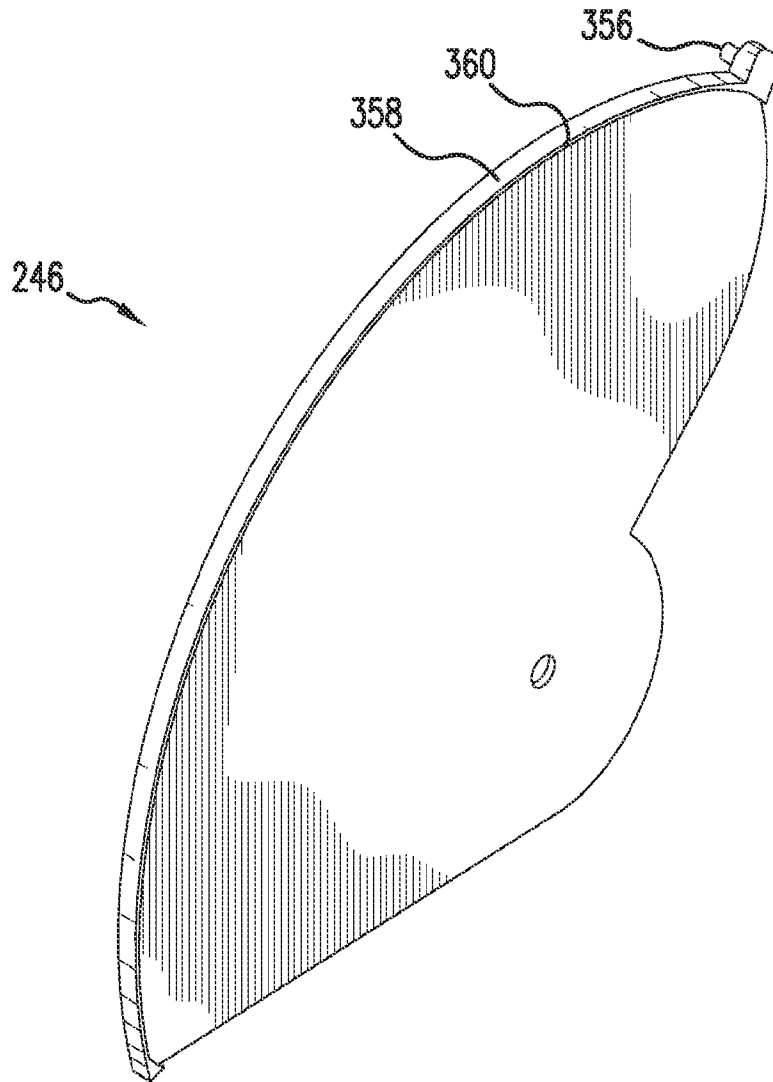

FIG. 33

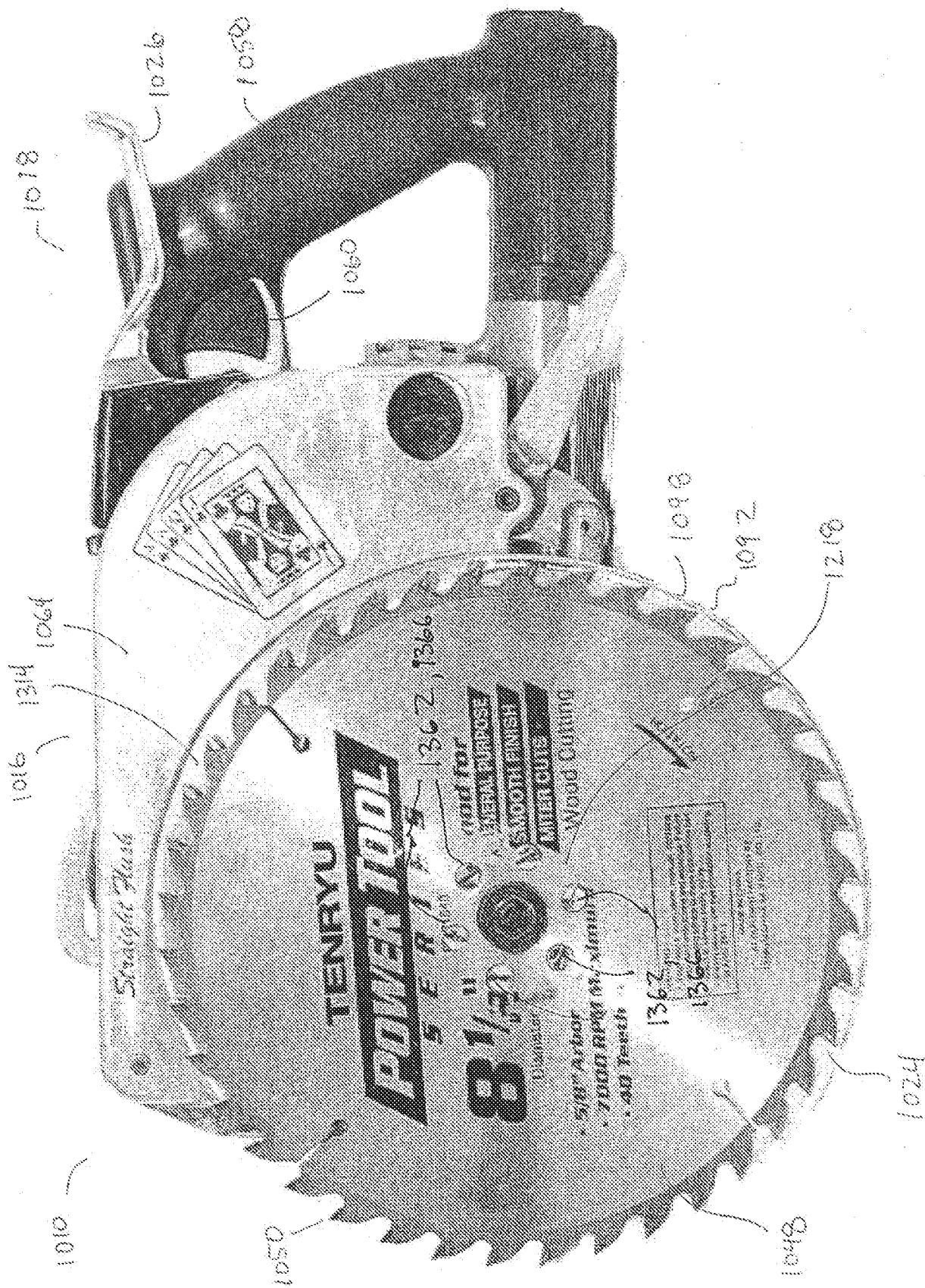

FIG. 3H

INTERNATIONAL SEARCH REPORT

International application No.

PCT/US2011/048323

A. CLASSIFICATION OF SUBJECT MATTER IPC(8) - B23D 51/01 (2012.01) USPC - 30/517 According to International Patent Classification (IPC) or to both national classification and IPC		
B. FIELDS SEARCHED Minimum documentation searched (classification system followed by classification symbols) IPC(8) - B23D 47/00, 51/01 (2012.01) USPC - 30/166.3, 276, 370, 375, 376, 377, 388, 390, 391, 517, 519; 144/218 Documentation searched other than minimum documentation to the extent that such documents are included in the fields searched Electronic data base consulted during the international search (name of data base and, where practicable, search terms used) MicroPatent		
C. DOCUMENTS CONSIDERED TO BE RELEVANT		
Category*	Citation of document, with indication, where appropriate, of the relevant passages	Relevant to claim No.
X	US 7,581,323 B2 (MIKLOSZ et al) 01 September 2009 (01.09.2009) entire document	30
--		-----
Y		1-11, 16-23
Y	US 7,739,801 B1 (CRAIN et al) 22 June 2010 (22.06.2010) entire document	1-11, 16-23
Y	US 2010/0162571 A1 (CHAMBERS) 01 July 2010 (01.07.2010) entire document	1-11, 16-23
Y	US 7,497,152 B2 (ZEILER et al) 03 March 2009 (03.03.2009) entire document	1-11, 16-23
Y	US 5,121,545 A (NONAKA et al) 16 June 1992 (16.06.1992) entire document	1-11, 16-23
Y	US 2009/0223069 A1 (PARKS) 10 September 2009 (10.09.2009) entire document	3-5, 18
Y	US 7,574,803 B2 (PARKER) 18 August 2009 (18.08.2009) entire document	7
Y	US 7,249,619 B2 (BERKOWITZ et al) 31 July 2007 (31.07.2007) entire document	8, 9
Y	US 2006/0169111 A1 (KOZLOWSKI) 03 August 2006 (03.08.2006) entire document	9
Y	US 4,241,505 A (BODYCOMB JR et al) 30 December 1980 (30.12.1980) entire document	23
A	US 6,701,629 B2 (KRONDORFER et al) 09 March 2004 (09.03.2004) entire document	12
<input type="checkbox"/> Further documents are listed in the continuation of Box C. <input type="checkbox"/>		
<p>* Special categories of cited documents:</p> <p>"A" document defining the general state of the art which is not considered to be of particular relevance</p> <p>"E" earlier application or patent but published on or after the international filing date</p> <p>"L" document which may throw doubts on priority claim(s) or which is cited to establish the publication date of another citation or other special reason (as specified)</p> <p>"O" document referring to an oral disclosure, use, exhibition or other means</p> <p>"P" document published prior to the international filing date but later than the priority date claimed</p> <p>"T" later document published after the international filing date or priority date and not in conflict with the application but cited to understand the principle or theory underlying the invention</p> <p>"X" document of particular relevance; the claimed invention cannot be considered novel or cannot be considered to involve an inventive step when the document is taken alone</p> <p>"Y" document of particular relevance; the claimed invention cannot be considered to involve an inventive step when the document is combined with one or more other such documents, such combination being obvious to a person skilled in the art</p> <p>"&" document member of the same patent family</p>		
Date of the actual completion of the international search 04 January 2012		Date of mailing of the international search report 13 JAN 2012
Name and mailing address of the ISA/US Mail Stop PCT, Attn: ISA/US, Commissioner for Patents P.O. Box 1450, Alexandria, Virginia 22313-1450 Facsimile No. 571-273-3201		Authorized officer: Blaine R. Copenheaver PCT Helpdesk: 571-272-4300 PCT OSP: 571-272-7774