

(19) (KR)
(12) (Y1)

(51) 。 Int. Cl. ⁷ (45) 2002 06 22
A01G 9/24 (11) 20 - 0279129
(24) 2002 06 07

(21) 20 - 2002 - 0009900
(22) 2002 04 02

(73) 1119 - 3 967 1104

(72) 1119 - 3 967 1104

(74)
:
가 :

(54)

가 (100) (200) , (100)
(200)가 가 (50) , (50)
61a) (50) (75) , (75) (50) (61a) 1 (61) , ()
가 (71a) (75)가 1 (71) 가
(71a) 1 (61) (61,62) (80)
(50) 가 가 가 ,
(50) 가 가 가 .

4a

, , , ,

1 3

4a 4b

5a 5b

6

*

50... 61... 1

61a... 71... 1

71a... 75...

80...

가 ,

126279

가

가

가

가 .

가

0199957

1

3

(10) ,

(10)

(20) ,

(22)

(30)

1,2

(21)(21a)

()가

가

(22)

(45)가

(40)

2 3
90°

(30)

1,2
(45)

(21)(21a)

(31)

가

가

가

가

1

가

2

2

2

가

가

2

가

가

3

가

가

가가

(100)
(50)

가
(200)가

(100)

(75)

(200)

(75)

(50)
(50)

1 , 4a 4b , (50) (61a) (61a) (71a) (61a) (75)가
1 (61) , (61a) 가 .
(71)

(61a) 2 (71) (71a)
(71a) 1 (50) (75) (61) 가 .

5a 5b , (50)
(62b)가 (62a) 2 (62) ,
(62a) 2 (72a) (75)가 2 (72) ,
2 (62) 2 (72) (72b) .

(50) (75) (72b)
2 (72) (62a)
(72a) , (72b) .

6 , (50)
(80) , (80) 가 (claw;81) (81)
(82) , (80) 가 (75)가
3 (81) (ratchet;73a)가 3 (73) .
(73) (90) (91) (80) 가 .

(73) (80) (50) (75) 가 . , 3 (73) 3
(81) 가 , 3 (73)

(75) (200)가 (76a)가 (76) ,
(76) (77) (76a) (76a) (7)

(75)

가 가 .
가

3) (50) 가 (50) (61,62) (80) (71,72,7
(50) 가 (200) 가 , (100)

(57)

1.

가

가

2.

1

1

가

1

3.

1

2

가

가

2

2

2

4.

1

가

가

3

가

1

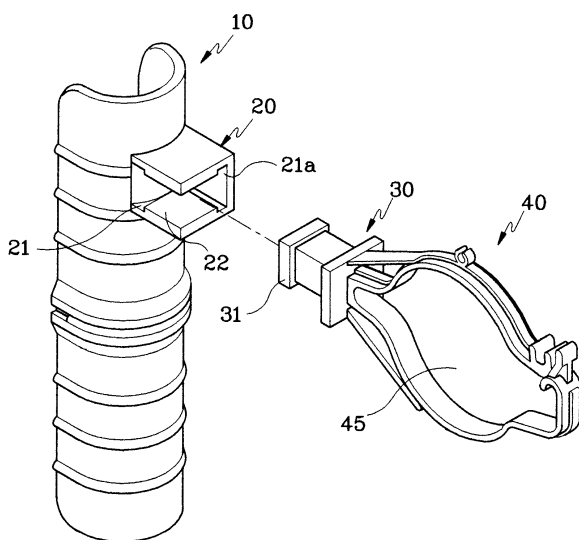

2

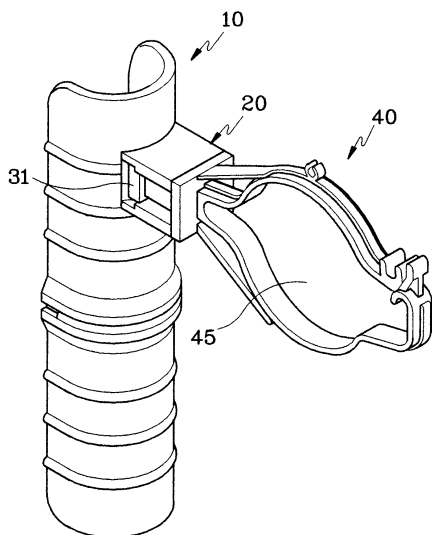

3

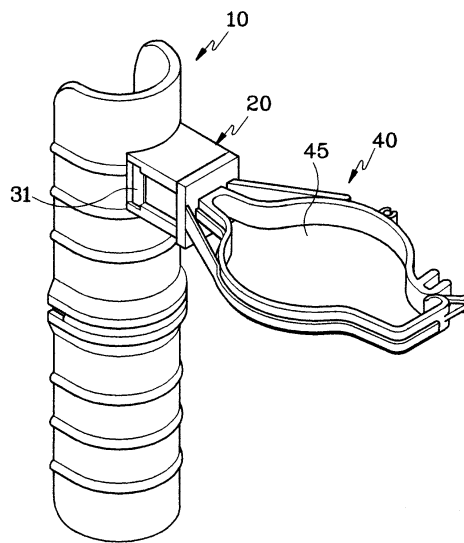

4a

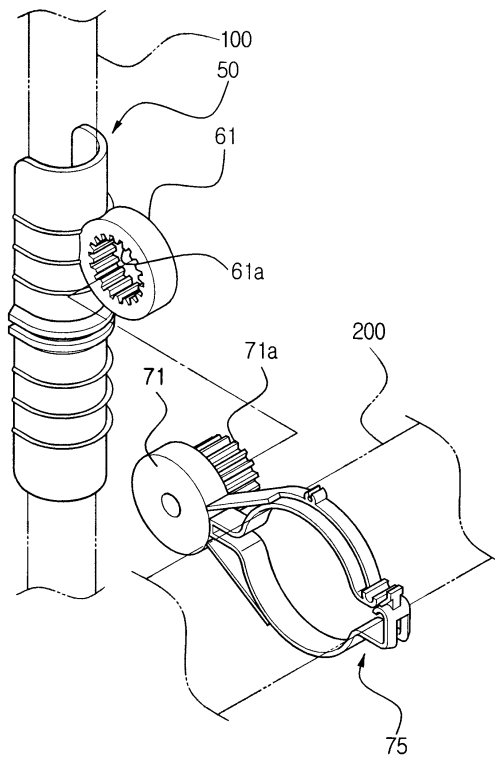

4b

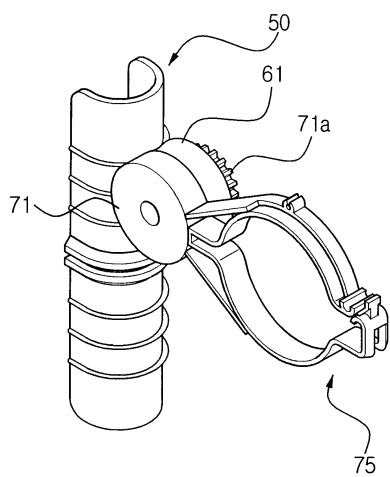

5a

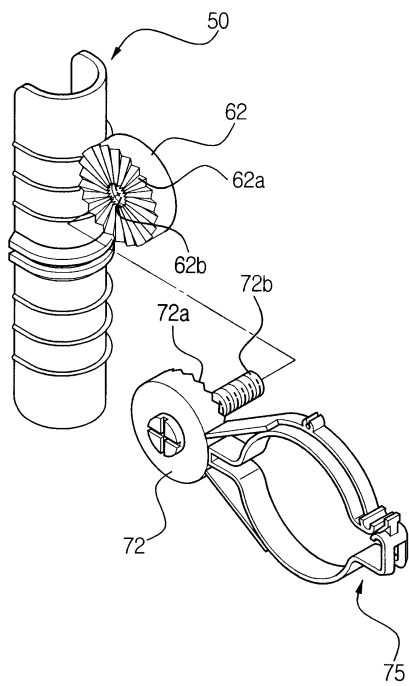

5b

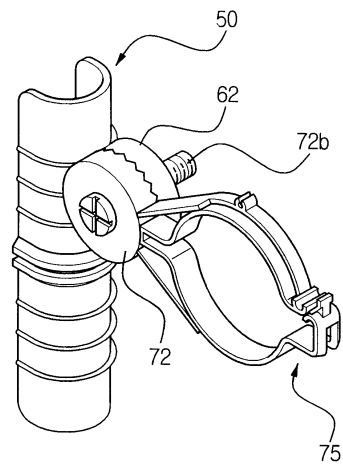

6

